



blumfeldt



**Highgrow Advanced**

**Hochbeet mit Gewächshausdach**

**Raised Garden Bed with Green House Roof**  
**Potager surélevé avec couvercle de serre**  
**Jardinera elevada con techo de invernadero**  
**Fioriera rialzata con tetto per serra**



10034687 10034688 10034689



---

## ARTIKEL

---

Artikelnummer	10034687	10034688	10034689
---------------	----------	----------	----------

### Hersteller:

Chal-Tec GmbH, Wallstraße 16, 10179 Berlin, Deutschland.









---





## SICHERHEITSHINWEISE











---

- Einige Teile haben scharfe Metallkanten. Seien Sie beim Umgang mit den Metallkanten vorsichtig. Tragen Sie während des Zusammenbaus Arbeitshandschuhe, Schuhe und eine Schutzbrille.
- Legen Sie alle Teile auf einen weichen Teppich oder eine Decke, um Kratzer und Beschädigungen zu vermeiden.
- Entfernen Sie vor dem Zusammenbau ca. 2 cm des Streifens von den Ecken der Metallbleche. Entfernen Sie nach der Montage den ganzen Film. Achten Sie darauf, dass die Seite mit den weißen Streifen nach außen zeigt.
- Wenn das Beet gereinigt werden muss, verwenden Sie einen milden Reiniger und spülen Sie es mit kaltem, sauberem Wasser. Verwenden Sie keinen Acetonreiniger oder andere Scheuermittel oder scharfen Reiniger, um die Panele zu reinigen.





# ZUSAMMENBAU

TEIL	NR	ANZ
	L01A	4
	L01B	4
	L02A	2
	L02B	2
	L03A	2
	L04A	2
	L04B	2
	L05A	1







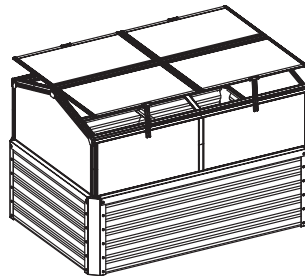

TEIL	NR	ANZ
	L06	4
	L07	4
	L08	8
	L33A	2
	L33B	2

TEIL	NR	ANZ
	J02	4
	J03	2
	J07	4
	J08	4
	J09	4
	W02	10
	Z02 M4X8	16
	Z01 M4X12D	38
	S01 M5X10	22
	M01 M5	22

TEIL	NR	ANZ
	Y1	4
	Y2	2
	Y4	4

TEIL	NR	ANZ
	W04	4
 800mm	Y11	2
 1100mm	Y12	2
	S02 M6X10	48
	M02 M6	48







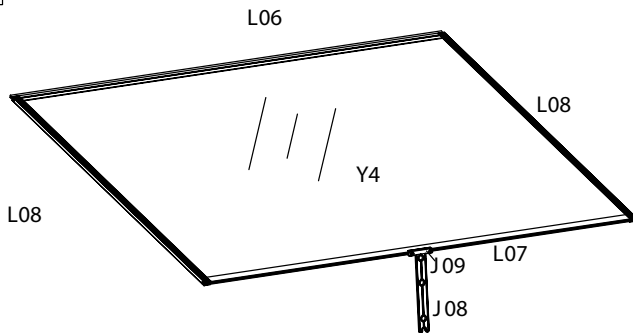
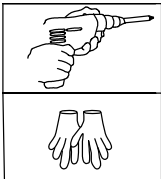
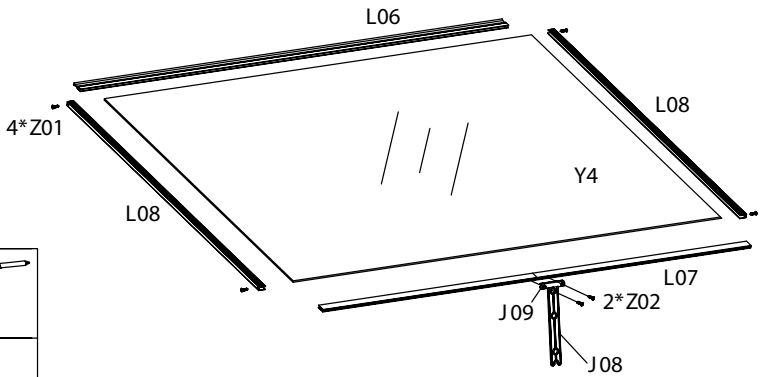

TEIL	NR	ANZ
	L06	1
	L07	1
	L08	2
	Z02 M4X8	2
	Z01 M4X12D	4
	J09	1
	J08	1
	Y4	1

### Fenstermontage







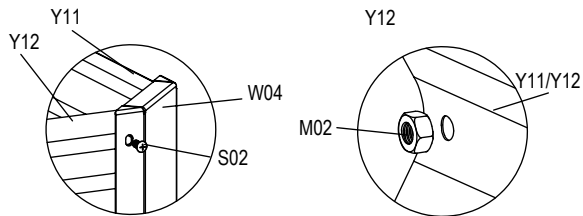
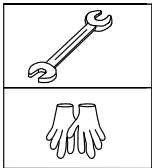
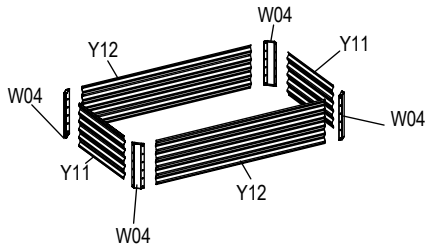

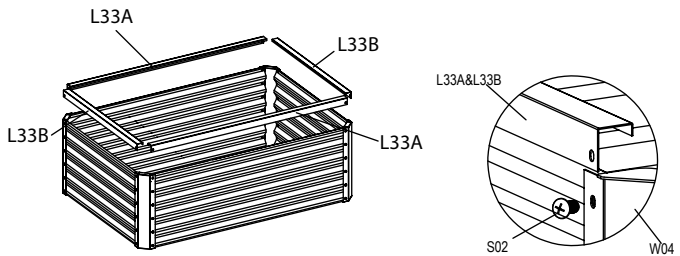

Befestigen Sie die Platten mit den Ecken (W04). Verwenden Sie die Schrauben S02 und M02.

TEIL	NR	ANZ
	W04	4
	L33A	2
	L33B	2
	Y11	2
	Y12	2
	S02	48
	M6X10	
	M02	48
	M6	



Befestigen Sie die Teile L33 und L33B an W04. Verwenden Sie die Schrauben S02 und M02.



TEIL	NR	ANZ
	L01A	4
	L02A	2
	L02B	2
	W02	10
	S01 M5X10	14
	M01 M5	14
	Z01 M4X12D	4

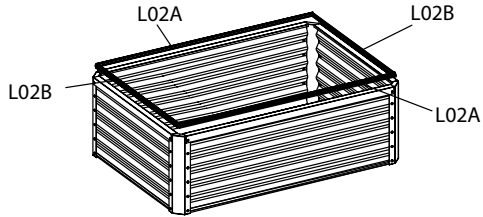

Schieben Sie 3 Schrauben (S01) in die Schiene von L02A. Befestigen Sie L02A an L33A. Verwenden Sie die Schrauben S01 und M01 in einem Abstand von jeweils 40 cm.



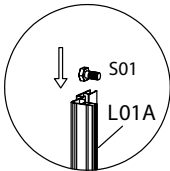
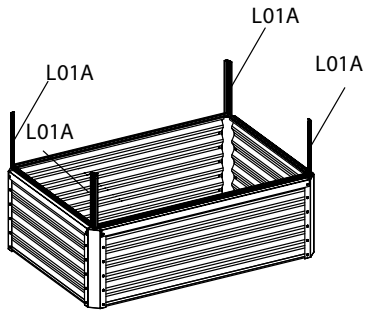
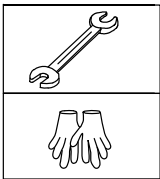
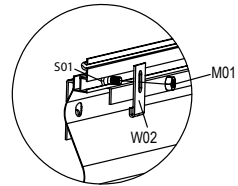



Schieben Sie 2 Schrauben S01 in die Schiene der beiden Teile L02B. Befestigen Sie L02B an L33B. Verwenden Sie die Schrauben S01 und M01 in einem Abstand von jeweils 40 cm.

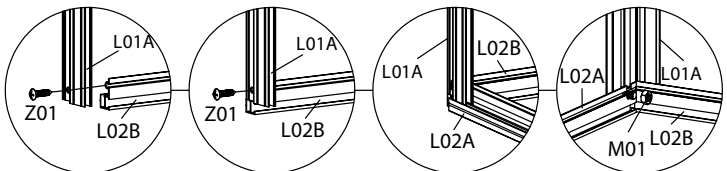

Bringen Sie L01A an L02B an. Verwenden Sie die Schrauben S01 und M01.

Schieben Sie die Schraube (S01) in die Schiene von L01A.



TEIL	NR	ANZ
	L03A	2
	L04A	2
	Y1	4
	Z01 M4X12D	4
	S01 M5X10	4
	M01 M5	4

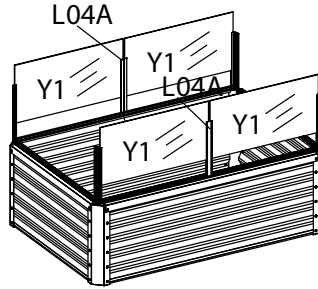

Schieben Sie 2 Schrauben (S01) in die Schiene von L04A.

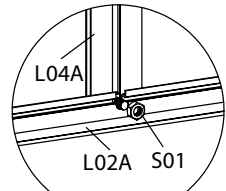
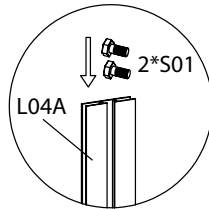

Befestigen Sie L04A an L02A. Verwenden Sie eine Schraube S01 und M01.

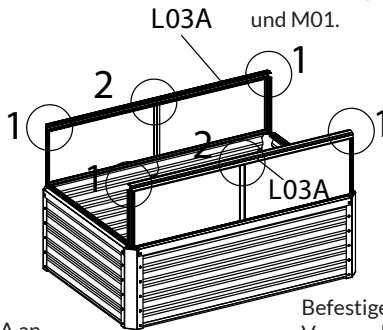
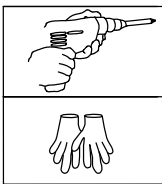



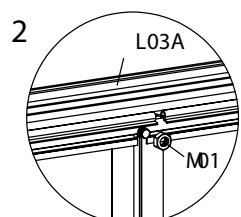
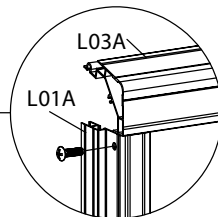
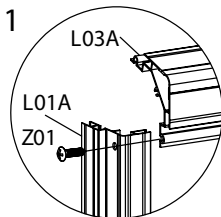

Befestigen Sie die Teile L03A an L01A mit einer Schraube Z01.

Befestigen Sie L03A an L04A. Verwenden Sie eine weitere Schraube S01 und M01.





TEIL	NR	ANZ
	L05A	1
	L01B	4
	Y2	2
	Z01 M4X12D	8

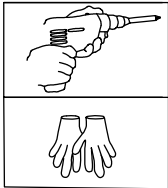
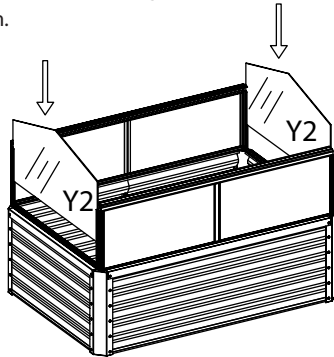

Setzen Sie die Teile Y2 in die Schiene von L01A ein.

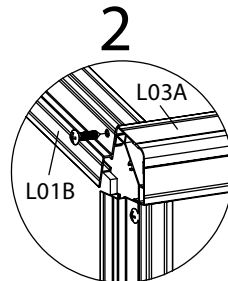
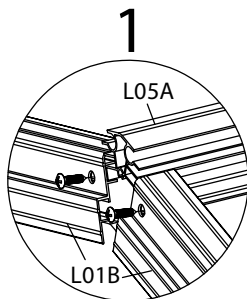
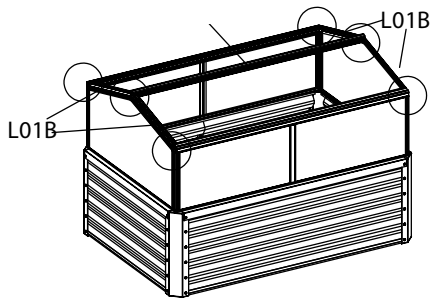

Befestigen Sie das Teil L01A an L01A und L03A.  
Dazu verwenden Sie eine Schraube Z01.

Befestigen Sie das Teil L05A an L01B mit einer  
Schraube Z01.



TEIL	NR	ANZ
	L04B	2
	S01 M5X10	4
	M01 M5	4

Setzen Sie 2 Schrauben S01 in jeweils ein Teil L04B.

Befestigen Sie L04B an L03A und L05A mit Hilfe der Schrauben S01 und M01.

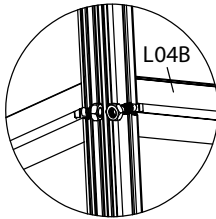
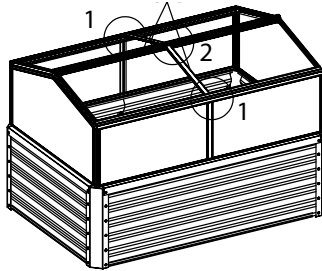
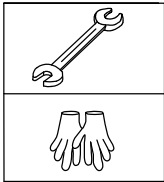

1

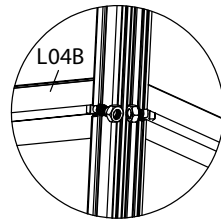

2

Schieben Sie die Fensterplatten in die Schienen von L05A

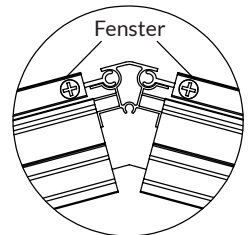
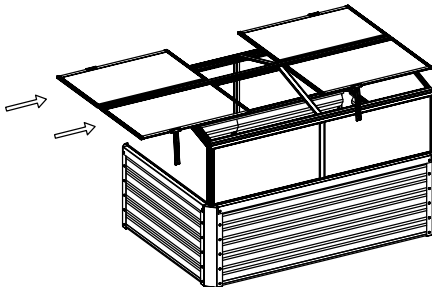

TEIL	NR	ANZ
	J02	4
TËIL	NR	ANZ
	J07	4
	Z01 M4X12D	6
	Z02 M4X8	8

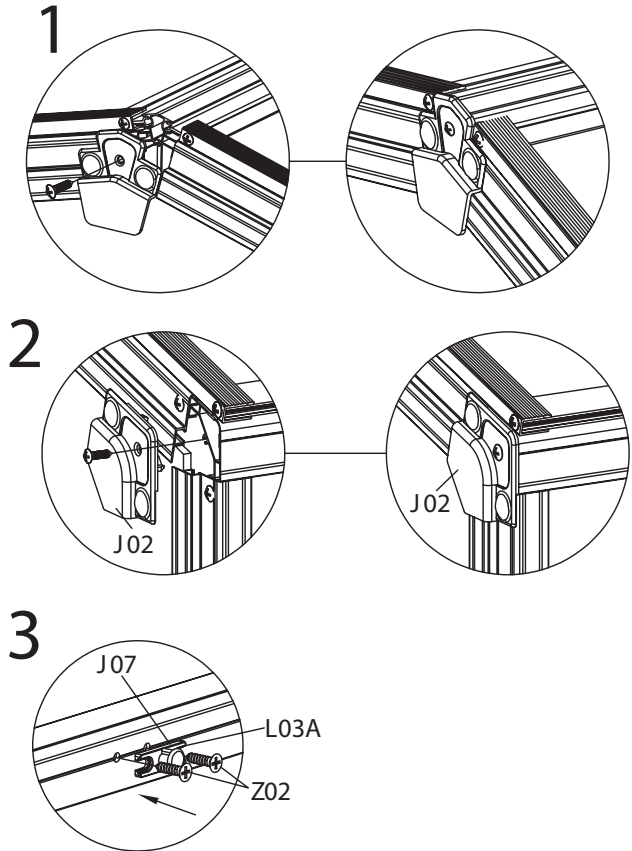
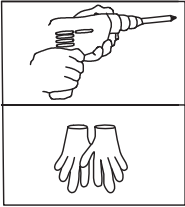
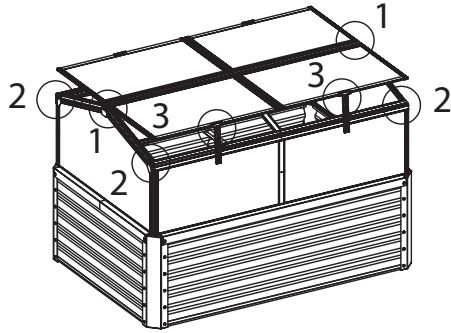



---

## ITEM

---

Item number	10034687	10034688	10034689
-------------	----------	----------	----------

**Producer:**

Chal-Tec GmbH, Wallstraße 16, 10179 Berlin, Deutschland.

---









## SAFETY INSTRUCTIONS





---











- Some components have sharp metal edges. Please be careful when handling metal components. Please wear gloves, shoes and safety goggles during assembly.
- Lay all of the components on a soft carpet or blanket to avoid any scratches or damages.
- Remove approximately 2 inches of film from all sheet edges before installing and remove all film immediately after the construction is completed. Please ensure that the side with the white film faces outwards.
- When your product needs cleaning, use a mild detergent solution and rinse with cold clean water. Do not use acetone, abrasive cleaners or strong detergents to clean the panels.

# ASSEMBLY





## Parts

PART	NO	QTY
	L01A	4
	L01B	4
	L02A	2
	L02B	2
	L03A	2
	L04A	2
	L04B	2
	L05A	1







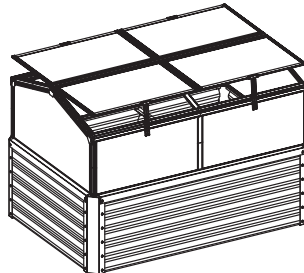

PART	NO	QTY
	L06	4
	L07	4
	L08	8
	L33A	2
	L33B	2

PART	NO	QTY
	J02	4
	J03	2
	J07	4
	J08	4
	J09	4
	W02	10
	Z02 M4X8	16
	Z01 M4X12D	38
	S01 M5X10	22
	M01 M5	22

PART	NO	QTY
	Y1	4
	Y2	2
	Y4	4







PART	NO	QTY
	W04	4
 800mm	Y11	2
 1100mm	Y12	2
 S02 M6X10		48
 M02 M6		48

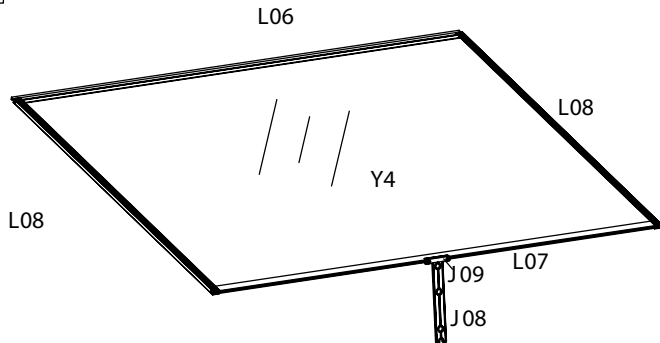
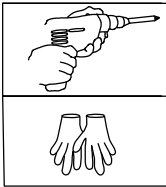
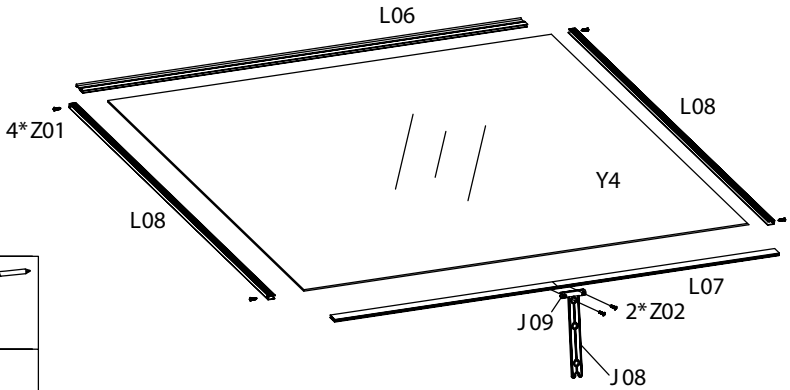

PART	NO	QTY
	L06	1
	L07	1
	L08	2
	Z02 M4X8	2
	Z01 M4X12D	4
	J09	1
	J08	1
	Y4	1

## Window Assembly



PART	NO	QTY
	W04	4
	L33A	2
	L33B	2
	Y11	2
	Y12	2
	S02	48
	M6X10	
	M02	48
	M6	



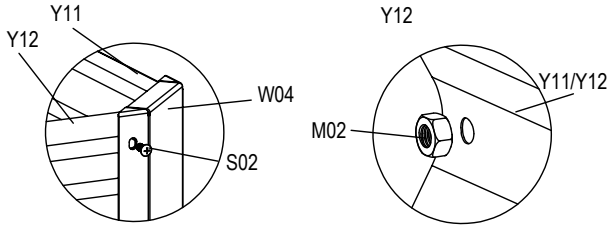
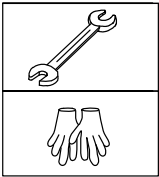
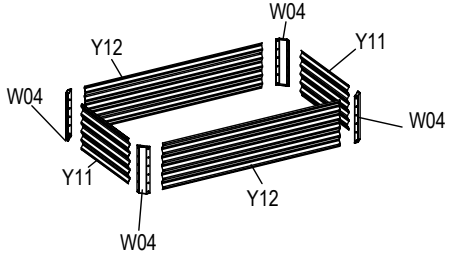

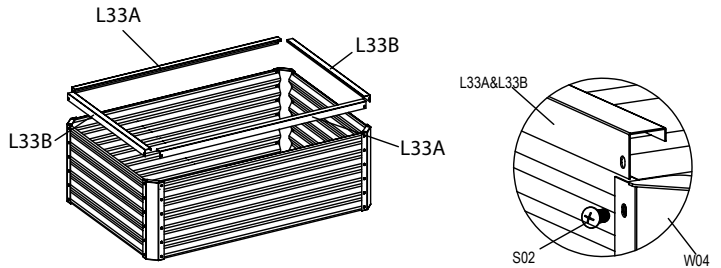

Fix the plates together with W04, using S02 & M02 as shown



Fix L33A & L33B to W04 using S02 & M02





PART	NO	QTY
	L01A	4
	L02A	2
	L02B	2
	W02	10
	S01 M5X10	14
	M01 M5	14
	Z01 M4X12D	4

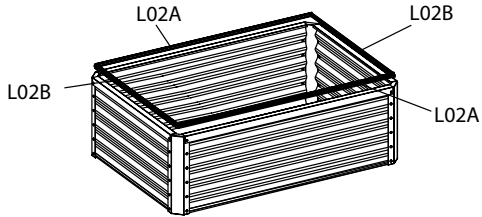



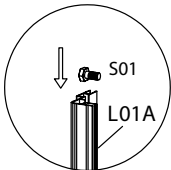
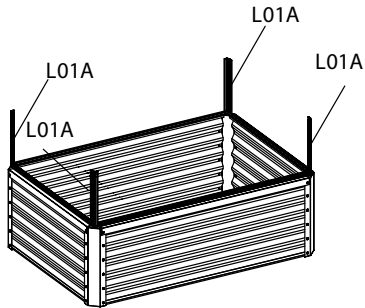
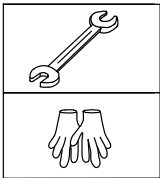
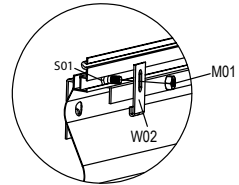



Slide 3\*S01 into the channel of each L02A, fix L02A to L33A using S01 & M01 at a distance about 40CM of each.  
Slide 2\*S01 into the channel of each L02B, fix L02B to L33B using S01 & M01 at a distance about 40CM of each.

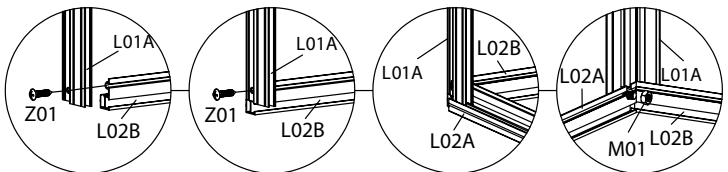

Slide 1\*S01 into the channel of L01A

Fix L01A to L02A & L02B using S01 & M01 and screw Z01.



PART	NO	QTY
	L03A	2
	L04A	2
	Y1	4
	Z01 M4X12D	4
	S01 M5X10	4
	M01 M5	4

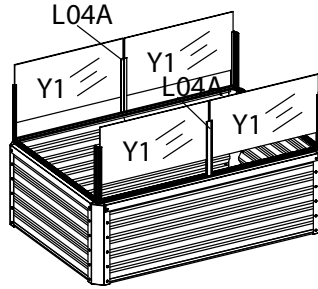

Slide 2\*S01 into the channel of L04A

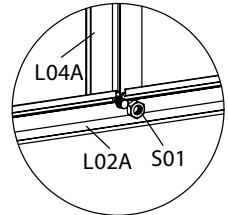
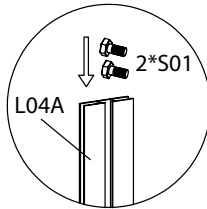

Fix L04A to L02A, using one S01 & M01

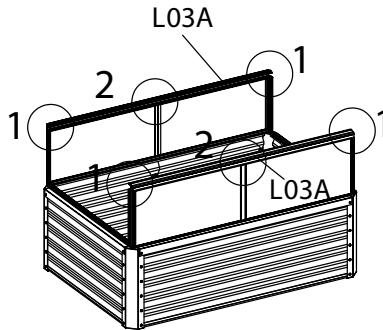
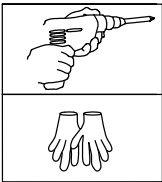

Fix L03A to L01A, using Z01

Fix L03A to L04A, using another S01 & M01

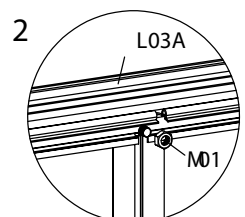
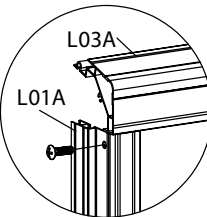
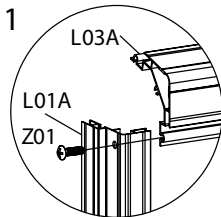



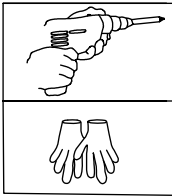
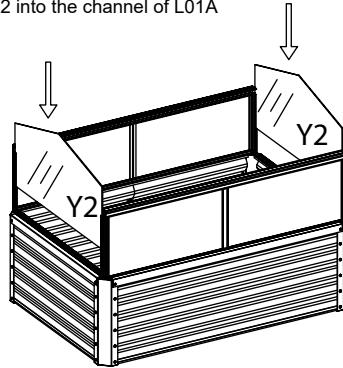

PART	NO	QTY
	L05A	1
	L01B	4
	Y2	2
	Z01 M4X12D	8

Insert Y2 into the channel of L01A

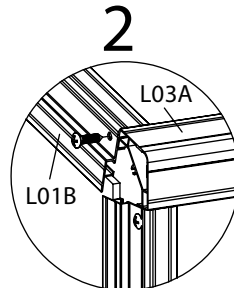
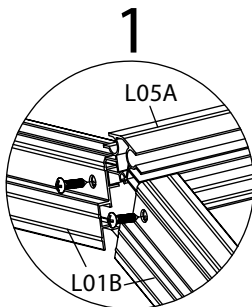
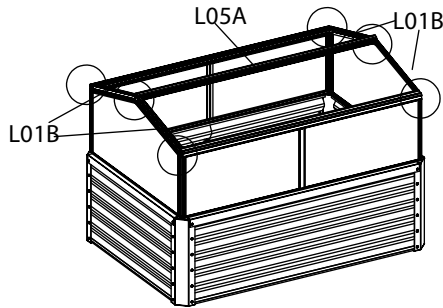

Fix L01B to L01A & L03A, using screw Z01.  
Then, fix L05A to L01B using screw Z01.



PART	NO	QTY
	L04B	2
	S01 M5X10	4
	M01 M5	4

Slide 2\*S01 into each L04B.  
Fix L04B to L03A & L05A, using S01 & M01.

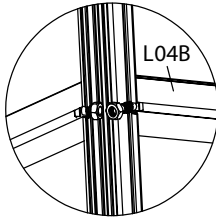
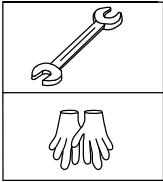
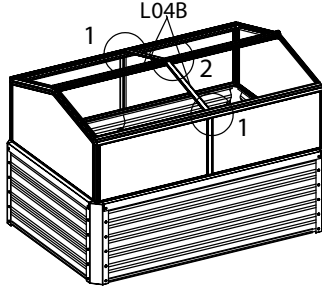



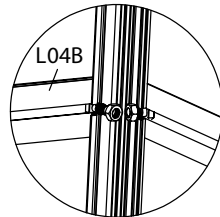



1

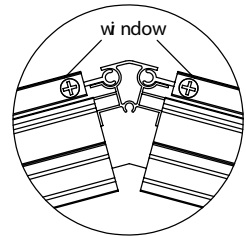
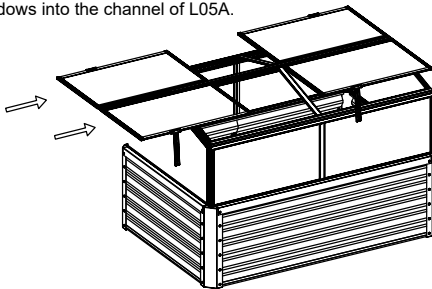

2

Slide the windows into the channel of L05A.



PART	NO	QTY
	J02	4
	J03	2
	J07	4
	Z01 M4X12D	6
	Z02 M4X8	8

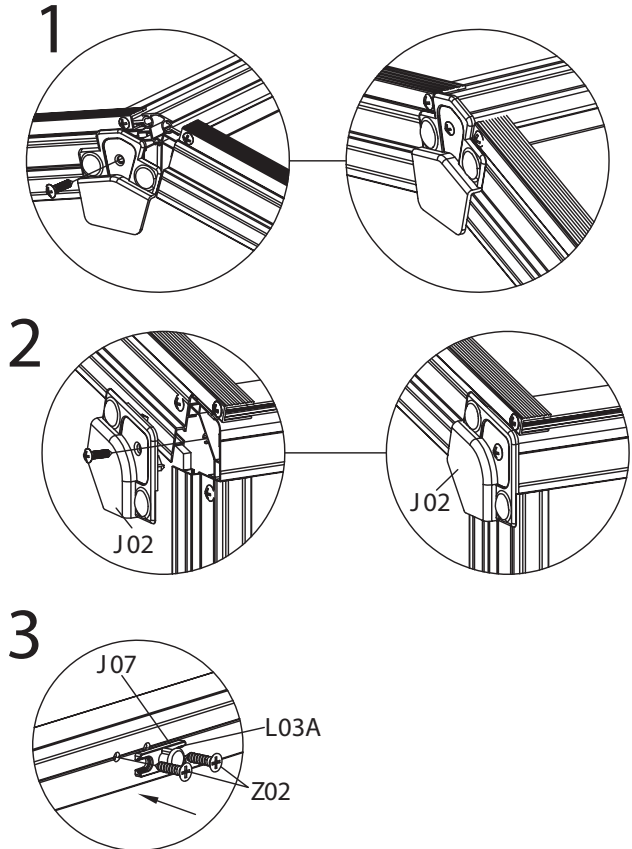
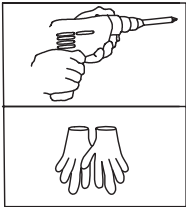
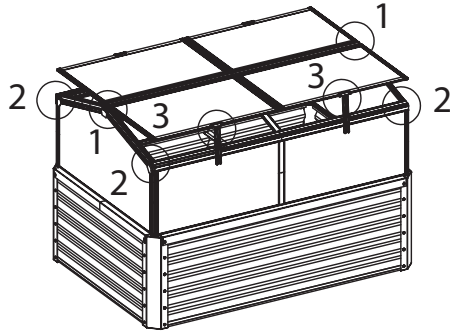



---

## ARTICLE

---

Numéro d'article	10034687	10034688	10034689
------------------	----------	----------	----------

**Fabricant :**

Chal-Tec GmbH, Wallstraße 16, 10179 Berlin, Allemagne.

---

## CONSIGNES DE SÉCURITÉ

---

- Certaines pièces ont des bords métalliques tranchants. Soyez prudent lorsque vous manipulez les bords métalliques. Portez des gants, des chaussures et des lunettes de protection pendant le montage.
- Posez toutes les pièces sur un tapis ou une couverture douce pour éviter les égratignures et les dommages.
- Avant l'assemblage, retirez environ 2 cm de film des coins des panneaux métalliques. Retirez le film entier après l'installation. Assurez-vous que le côté avec les bandes blanches est tourné vers l'extérieur.
- Si vous devez nettoyer le potager surélevé, utilisez un détergent doux et rincez-le à l'eau froide et propre. N'utilisez pas de nettoyant à l'acétone ni d'autres nettoyants abrasifs ou coupants pour nettoyer les panneaux.

## ASSEMBLAGE

PCE	NUM.	QTÉ
	L01A	4
	L01B	4
	L02A	2
	L02B	2
	L03A	2
	L04A	2
	L04B	2
	L05A	1

PCE	NUM.	QTÉ
	L06	4
	L07	4
	L08	8
	L33A	2
	L33B	2







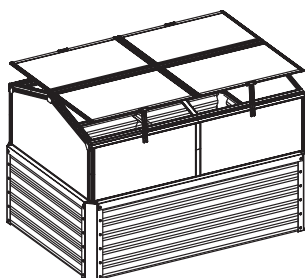

PCE	NUM.	QTÉ
	J02	4
	J03	2
	J07	4
	J08	4
	J09	4
	W02	10
	Z02 M4X8	16
	Z01 M4X12D	38
	S01 M5X10	22
	M01 M5	22

PCE	NUM.	QTÉ
	Y1	4
	Y2	2
	Y4	4

PCE	NUM.	QTÉ
	W04	4
	Y11 800mm	2
	Y12 1100mm	2
	S02 M6X10	48
	M02 M6	48









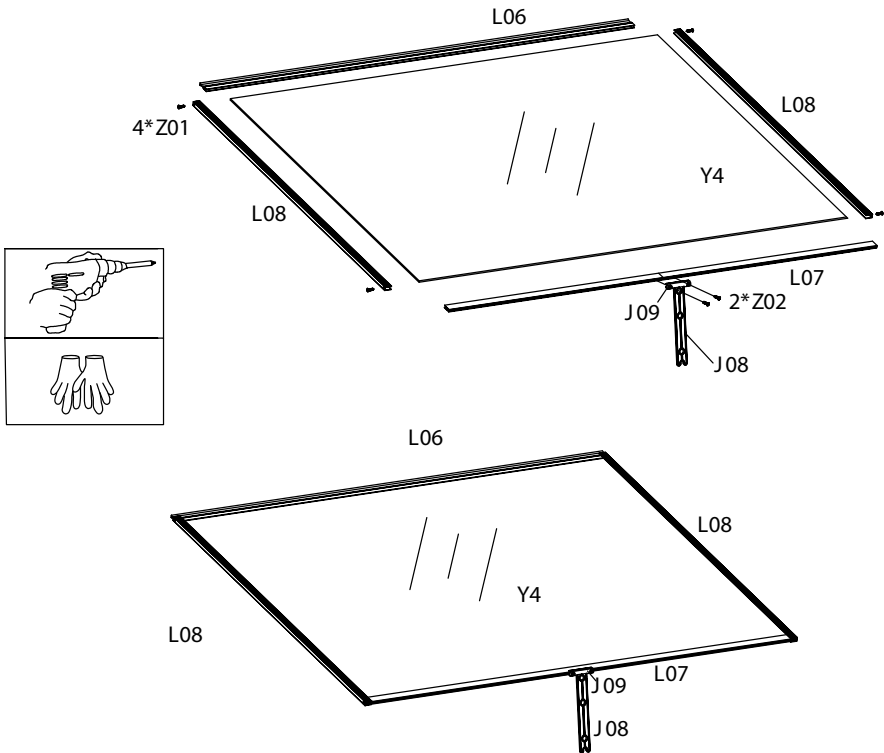

PCE	NUM.	QTÉ
	L06	1
	L07	1
	L08	2
	Z02 M4X8	2
	Z01 M4X12D	4
	J09	1
	J08	1
	Y4	1

## Installation des vitres







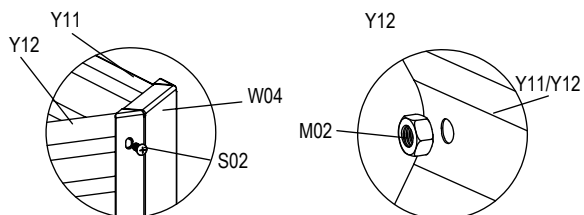
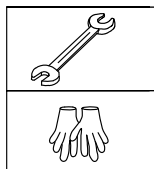
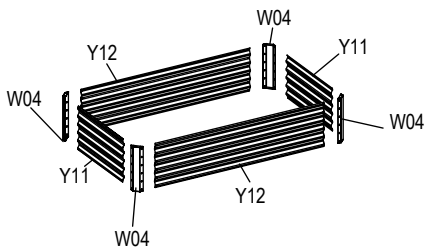

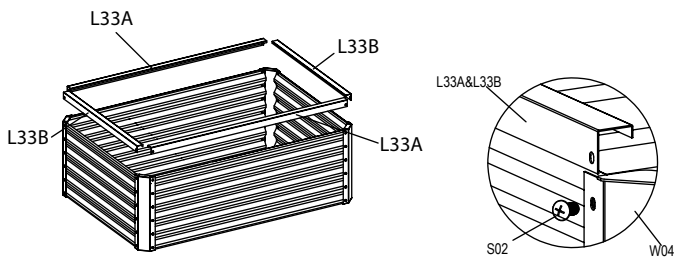

Fixez les panneaux avec les coins (W04). Utilisez les vis S02 et M02.

PCE	NUM.	QTÉ
	W04	4
	L33A	2
	L33B	2
	Y11	2
	Y12	2
	S02 M6X10	48
	M02 M6	48



Fixez les pièces L33 et L33B à W04. Utilisez les vis S02 et M02.



PCE	NUM	QTÉ
	L01A	4
	L02A	2
	L02B	2
	W02	10
	S01 M5X10	14
	M01 M5	14
	Z01 M4X12D	4

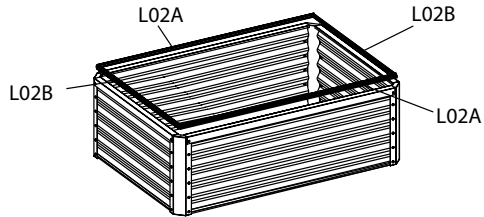

Insérez 3 vis (S01) dans le rail de L02A. Fixez L02A à L33A. Utilisez les vis S01 et M01 avec un espacement de 40 cm.



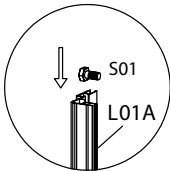
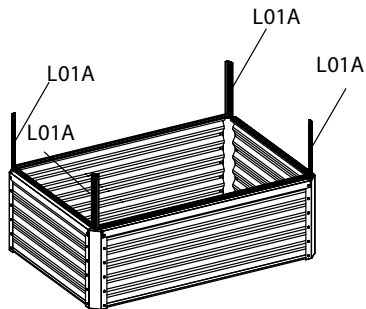
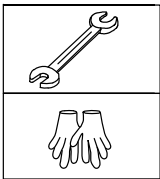
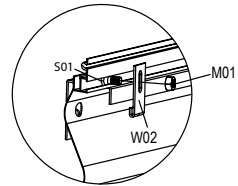



Insérez 3 vis (S01) dans le rail des deux parties L02B. Fixez L02B à L33B. Utilisez les vis S01 et M01 avec un espacement de 40 cm.

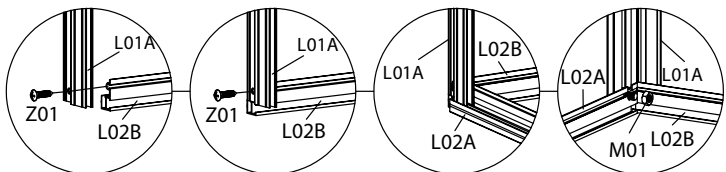

Fixez L01A à L02B. Utilisez les vis S01 et M01.

Faites glisser la vis (S01) dans le rail de L01A.



PCE	NUM	QTÉ
	L03A	2
	L04A	2
	Y1	4
	Z01 M4X12D	4
	S01 M5X10	4
	M01 M5	4

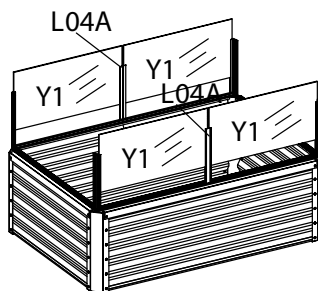

Faites glisser 2 vis (S01) dans le rail de L04A.

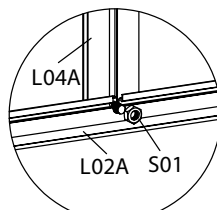
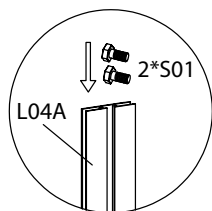



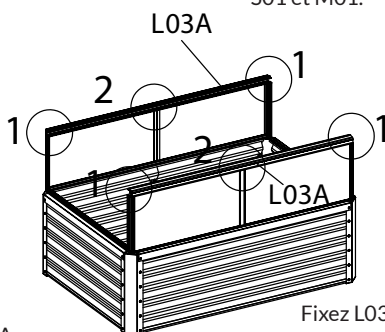
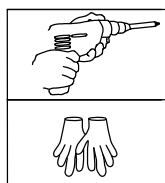

Fixez L04A à L02A. Utilisez une vis S01 et M01.

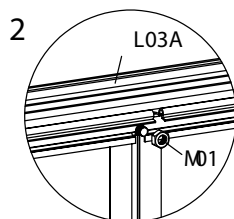
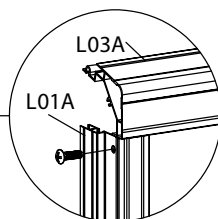
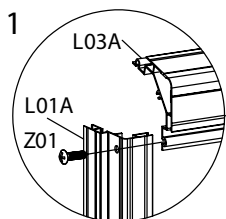

Fixez les pièces L03A à L01A avec une vis Z01.

Fixez L03A à L04A. Utilisez une vis S01 et M01.



PCE	NUM	QTÉ
	L05A	1
	L01B	4
	Y2	2
	Z01 M4X12D	8

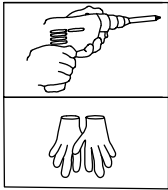
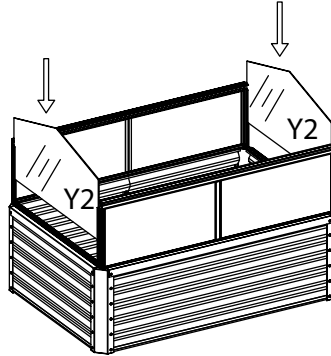

Insérez les pièces Y2 dans le rail du L01A.

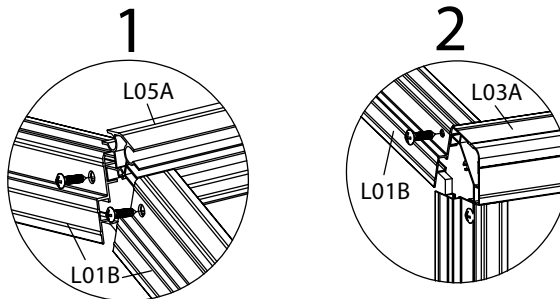
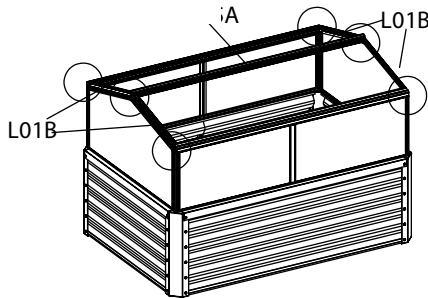

Fixez les pièces L01A à L01A et L03A.  
Utilisez pour cela une vis Z01.

Fixez la pièce L05A à L01B avec une vis Z01.



PCE	NUM	QTÉ
	L04B	2
	S01 M5X10	4
	M01 M5	4

Insérez 2 vis S01 dans chaque partie L04B.

Fixez L04B sur L03A et L05A avec les vis S01 et M01.

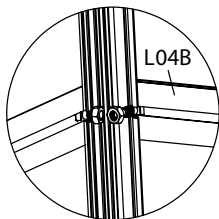
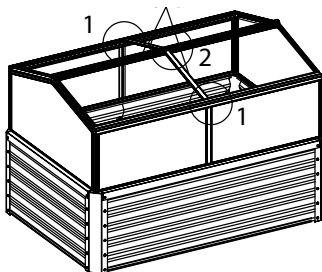
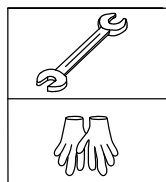



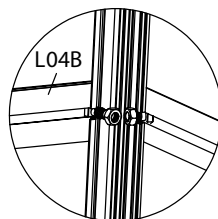

1

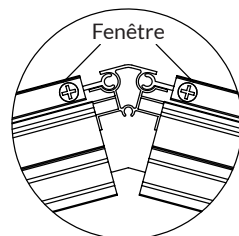
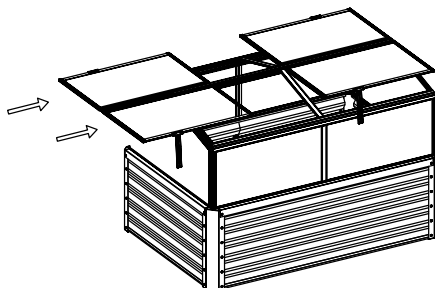

2

Faites glisser les panneaux de fenêtre dans les rails de L05A.



PCE	NUM.	QTÉ
	J02	4
PĀE	NUM.	QTÉ
	J07	4
	Z01 M4X12D	6
	Z02 M4X8	8

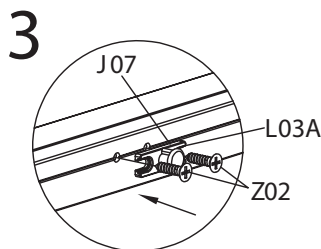
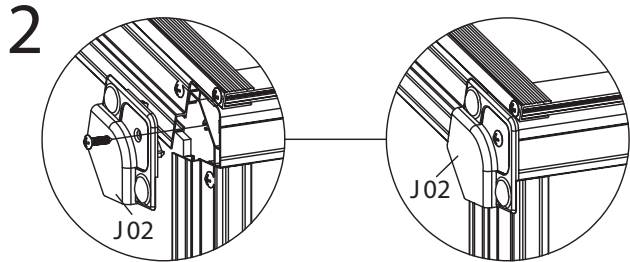
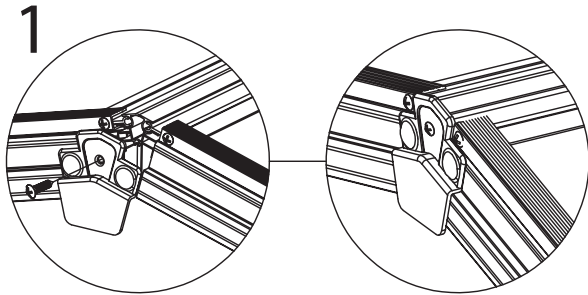
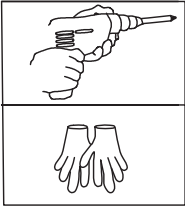
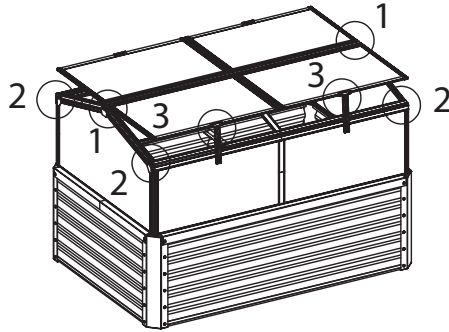





---

## ARTÍCULO

---

Número artículo	10034687	10034688	10034689
-----------------	----------	----------	----------

**Fabricante :**

Chal-Tec GmbH, Wallstraße 16, 10179 Berlín, Alemania.









---





## INSTRUCCIONES DE SEGURIDAD











---



- Algunas piezas tienen cantos metálicos afilados. Tenga mucho cuidado al manipularlos. Póngase durante la manipulación y el montaje guantes de trabajo, botas de seguridad y gafas de protección.
- Coloque todas las piezas sobre una alfombra o una manta para evitar arañazos o daños.
- Antes del montaje retire unos 2 cm. de la cinta de los bordes de las piezas metálicas y retire toda la cinta después del montaje. Asegúrese de que las piezas con cinta blanca miran hacia fuera.
- Para limpiar el producto utilice un detergente suave y aclárelo con agua limpia fría. No use acetona u otro producto abrasivo o corrosivo.





# MONTAJE

PZA.	NÚM.	CANT.
	L01A	4
	L01B	4
	L02A	2
	L02B	2
	L03A	2
	L04A	2
	L04B	2
	L05A	1







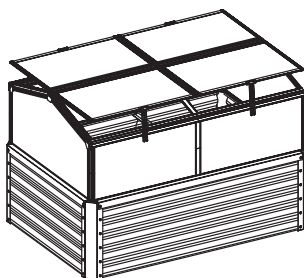

PZA.	NÚM.	CANT.
	L06	4
	L07	4
	L08	8
	L33A	2
	L33B	2

PZA.	NÚM.	CANT.
	J02	4
	J03	2
	J07	4
	J08	4
	J09	4
	W02	10
	Z02 M4X8	16
	Z01 M4X12D	38
	S01 M5X10	22
	M01 M5	22

PZA.	NÚM.	CANT.
	Y1	4
	Y2	2
	Y4	4

PZA.	NÚM.	CANT.
	W04	4
 800mm	Y11	2
 1100mm	Y12	2
	S02 M6X10	48
	M02 M6	48







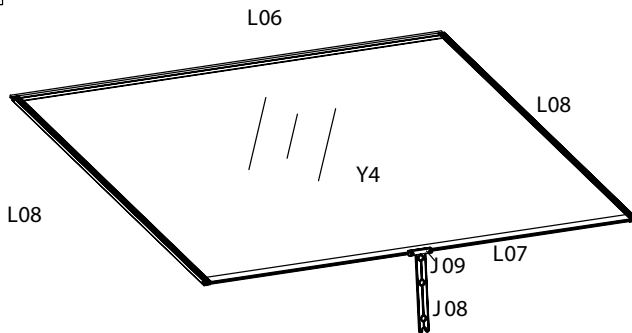
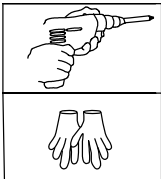
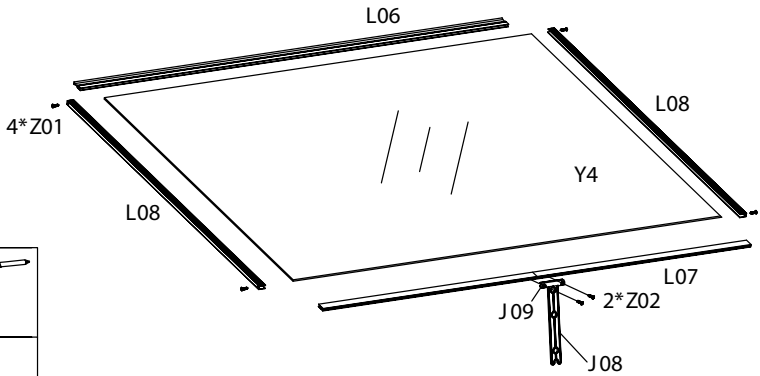

PZA.	NÚM.	CANT.
	L06	1
	L07	1
	L08	2
	Z02 M4X8	2
	Z01 M4X12D	4
	J09	1
	J08	1
	Y4	1

Montaje de la ventana



Fijar las placas con las esquinas (W04). Utilice los tornillos S02 y M02.

PZA.	NÚM.	CANT.
	W04	4
	L33A	2
	L33B	2
	Y11	2
	Y12	2
	S02 M6X10	48
	M02 M6	48

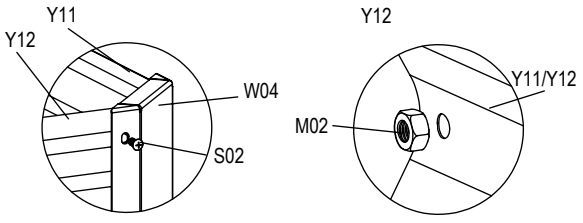
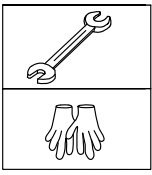
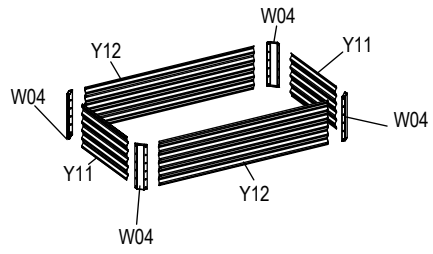

Fijar las piezas L33 y L33B a W04 con los tornillos S02 y M02.

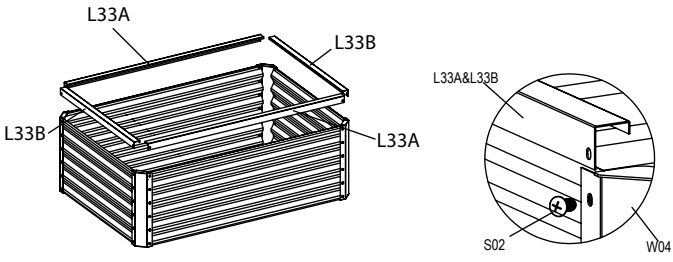

PZA.	NÚM.	CANT.
	L01A	4
	L02A	2
	L02B	2
	W02	10
	S01 M5X10	14
	M01 M5	14
	Z01 M4X12D	4

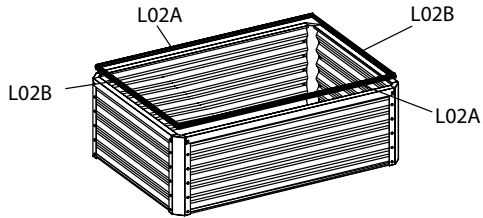

Introduzca 3 tornillos (S01) en la ranura L02A. Fíje la L02A a L33A utilizando las piezas S01 y M01 a una distancia de 40 cm.



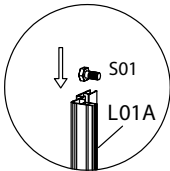
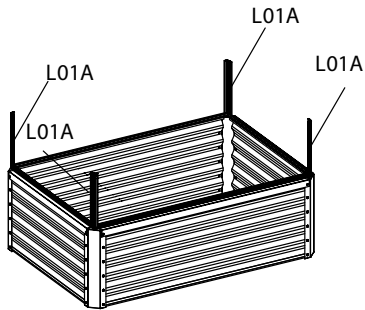
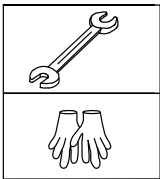
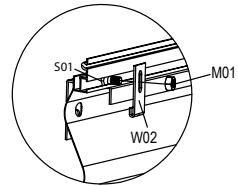



Introduzca 2 tornillos (S01) en la ranura de ambas piezas L02B. Fíje la L02B a L33B utilizando las piezas S01 y M01 a una distancia de 40 cm.

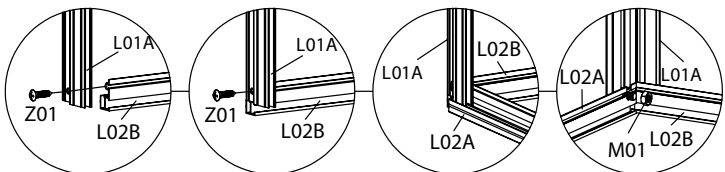

Conecte L01A a L02B. Utilice los tornillos S01 y M01.

Introduzca el tornillo (S01) en la ranura de L01A.



PZA.	NÚM.	CANT.
	L03A	2
	L04A	2
	Y1	4
	Z01 M4X12D	4
	S01 M5X10	4
	M01 M5	4

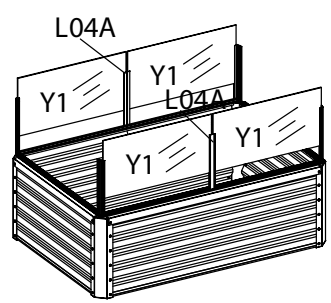

Deslice 2 tornillos (S01) en la ranura de L04A.

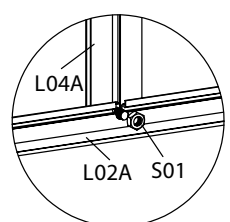
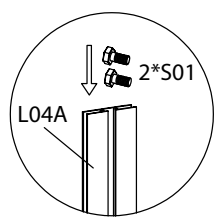

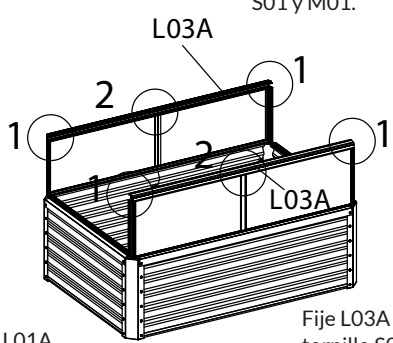
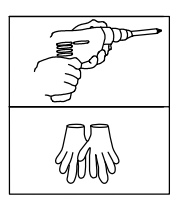

Fije L04A en L02A. Utilice un tornillo S01 y M01.

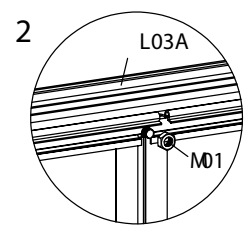
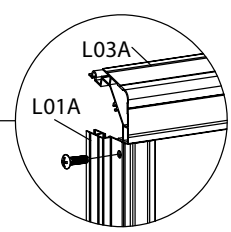
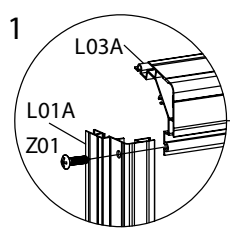

Fije L03A las piezas L03A a L01A con el tornillo Z01.

Fije L03A en L01A. Utilice otro tornillo S01 y M01.



PZA.	NÚM.	CANT.
	L05A	1
	L01B	4
	Y2	2
	Z01 M4X12D	8

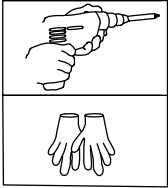
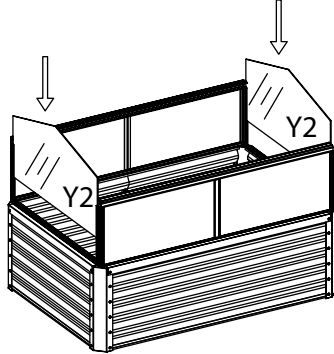

Coloque las piezas Y2 en las ranuras de L01A.

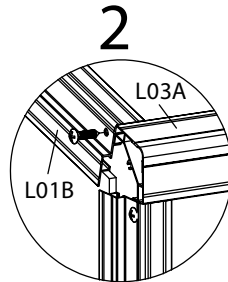
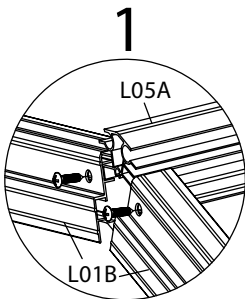
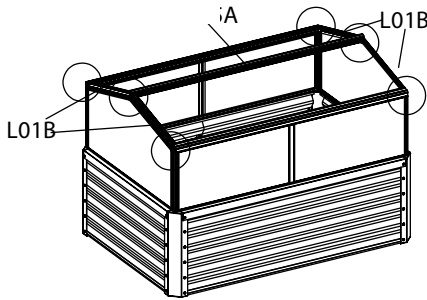

Fije las piezas L01A en L01A y L03A. Utilice en tornillo Z01.

Fije la pieza L05A en L01B con un tornillo Z01.



PZA.	NÚM.	CANT.
	L04B	2
	S01 M5X10	4
	M01 M5	4

Coloque dos tornillos S01 en sendas piezas L04B.

Fije la pieza L04B a L03A y L05A con los tornillos S01 y M01.

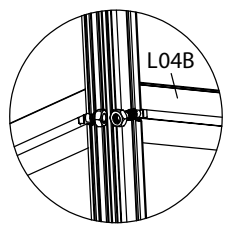
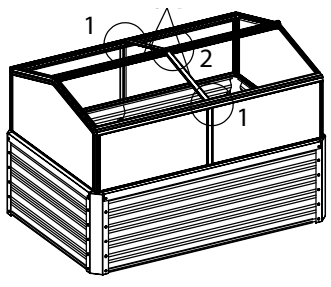
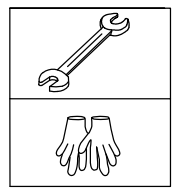

1

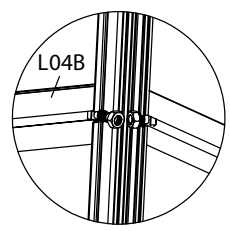



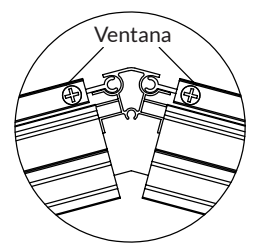
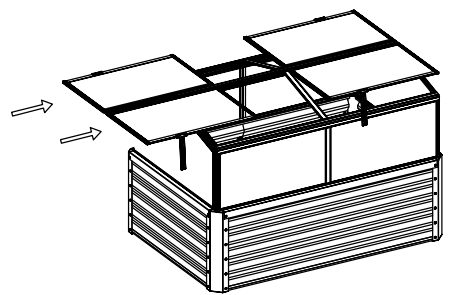

2

Deslice los paneles de la ventana en las ranuras de L05A





PZA.	NÚM.	CANT.
	J02	4
	J07	4
	Z01 M4X12D	6
	Z02 M4X8	8

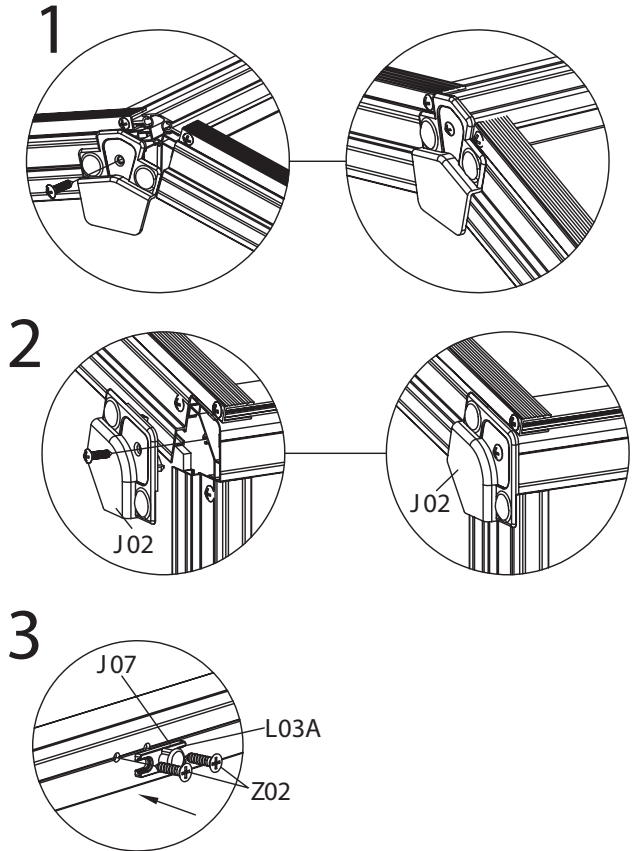
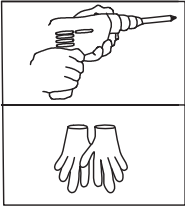
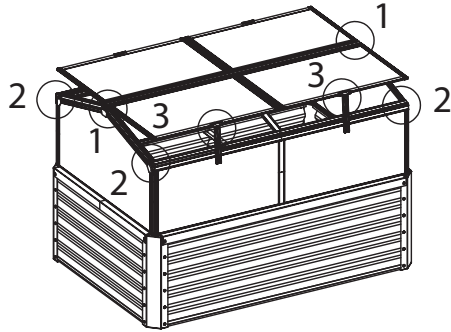



---

## ARTICOLO

---

Numero articolo	10034687	10034688	10034689
-----------------	----------	----------	----------

**Produttore:**

Chal-Tec GmbH, Wallstraße 16, 10179 Berlino, Germania.









---





## AVVERTENZE DI SICUREZZA











---



- Alcuni pezzi hanno spigoli metallici appuntiti. Fare attenzione nel maneggiare questi spigoli. Indossare guanti da lavoro, scarpe e occhiali di protezione durante il montaggio.
- Collocare tutti i pezzi su un tappeto morbido o una coperta per evitare graffi e danneggiamenti.
- Prima di iniziare il montaggio rimuovere ca. 2 cm di nastro bianco dagli angoli delle lamiere metalliche. Dopo il montaggio rimuovere tutta la pellicola. Fare attenzione che il lato con il nastro bianco sia rivolto verso l'esterno.
- Per pulire la fioriera utilizzare un detergente blando e lavarla con acqua fredda. Non usare acetone o altri prodotti abrasivi o detergenti aggressivi per pulire i pannelli.





## MONTAGGIO

PZ.	NUM.	QTÀ.
	L01A	4
	L01B	4
	L02A	2
	L02B	2
	L03A	2
	L04A	2
	L04B	2
	L05A	1







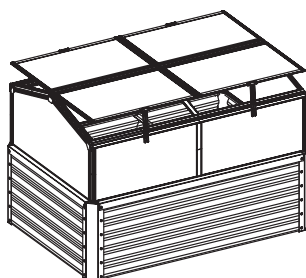

PZ.	NUM.	QTÀ.
	L06	4
	L07	4
	L08	8
	L33A	2
	L33B	2

PZ.	NUM.	QTÀ.
	J02	4
	J03	2
	J07	4
	J08	4
	J09	4
	W02	10
	Z02 M4X8	16
	Z01 M4X12D	38
	S01 M5X10	22
	M01 M5	22

PZ.	NUM.	QTÀ.
	Y1	4
	Y2	2
	Y4	4

PZ.	NUM.	QTÀ.
	W04	4
	Y11 800mm	2
	Y12 1100mm	2
	S02 M6X10	48
	M02 M6	48







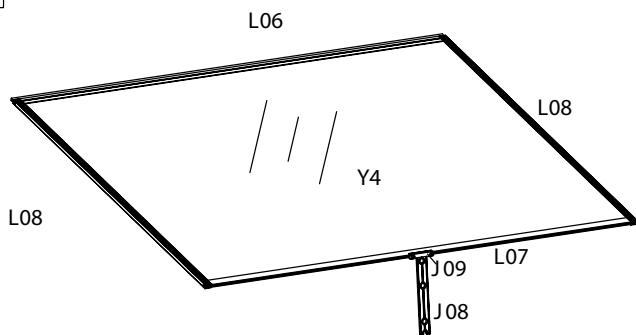
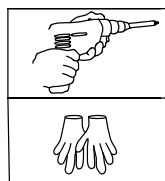
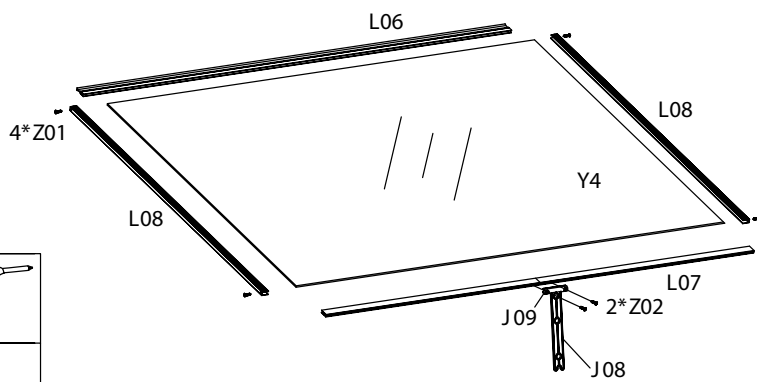

IPZA.	NUM.	QTA
	L06	1
	L07	1
	L08	2
	Z02 M4X8	2
	Z01 M4X12D	4
	J09	1
	J08	1
	Y4	1

## Montare la finestra



Montare i pannelli con gli angoli (W04). Utilizzare le viti S02 e M02.

PZ.	NUM.	QTÀ.
	W04	4
	L33A	2
	L33B	2
	Y11	2
	Y12	2
	S02 M6X10	48
	M02 M6	48

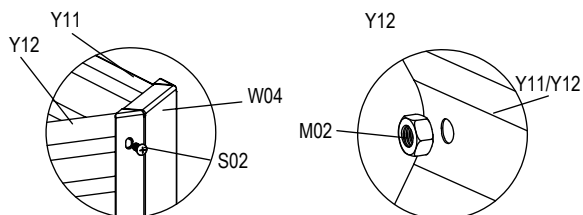
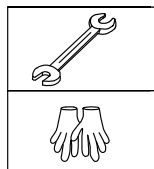
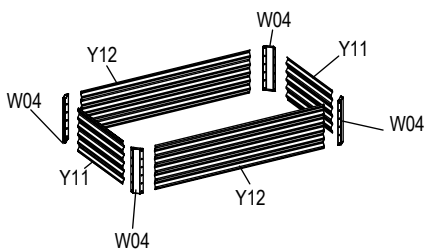

Fissare i pezzi L33 e L33B su W04. Utilizzare le viti S02 e M02.

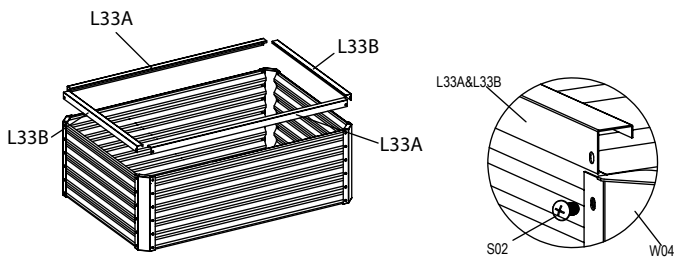

PZ.	NUM.	QTÀ.
	L01A	4
	L02A	2
	L02B	2
	W02	10
	S01 M5X10	14
	M01 M5	14
	Z01 M4X12D	4

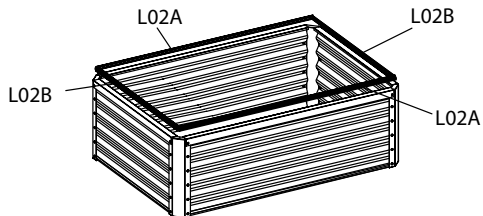

Spingere le 3 viti (S01) nella guida L02A. Fissare L02A su L33A.  
Utilizzare le viti S01 e M01 a una distanza di 40 cm l'una dall'altra.



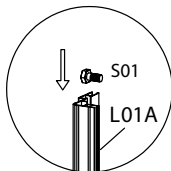
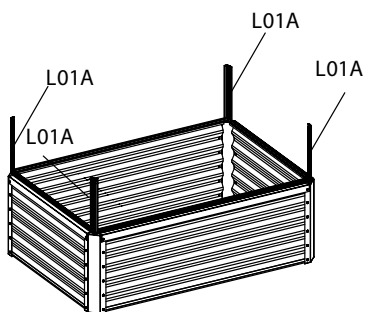
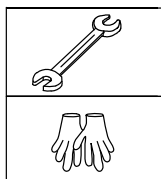
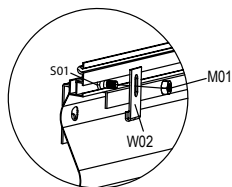



Spingere le 2 viti S01 nella guida di entrambi i pezzi L02B. Fissare L02B su L33B. Utilizzare le viti S01 e M01 a una distanza di 40 cm l'una dall'altra.

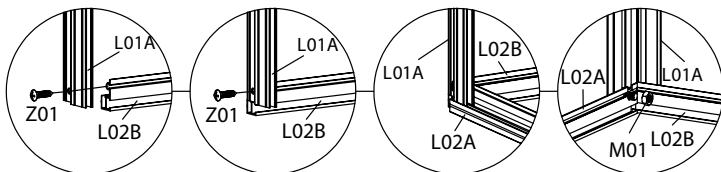

Applicare L01A su L02B. Utilizzare le viti S01 e M01.

Spingere la vite (S01)  
nella guida L01A.



PZ.	NUM.	QTÀ.
	L03A	2
	L04A	2
	Y1	4
	Z01 M4X12D	4
	S01 M5X10	4
	M01 M5	4

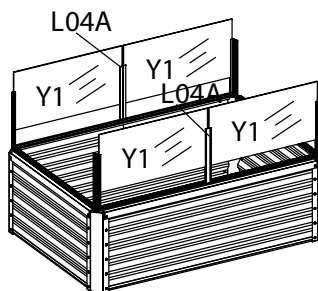

Spingere le 2 viti (S01) nella guida L04A.

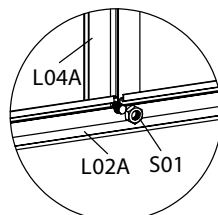
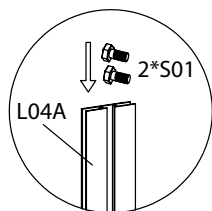

Fissare L04A su L02A. Utilizzare una vite S01 e M01.

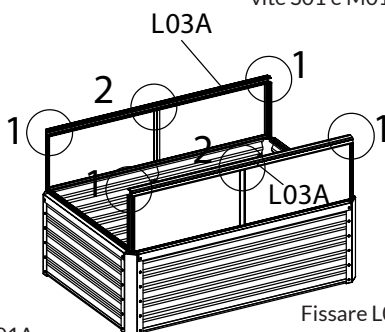
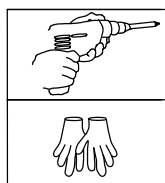



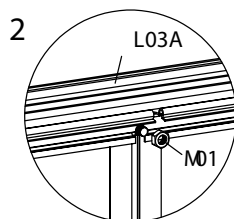
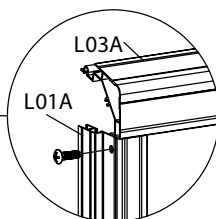
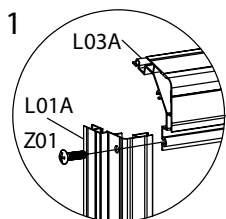

Fissare le parti da L03A a L01A con la vite Z01.

Fissare L03A su L04A. Utilizzare una vite S01 e M01.





PZ.	NUM.	QTÀ.
	L05A	1
	L01B	4
	Y2	2
	Z01 M4X12D	8

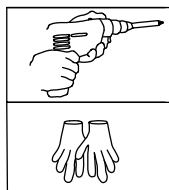
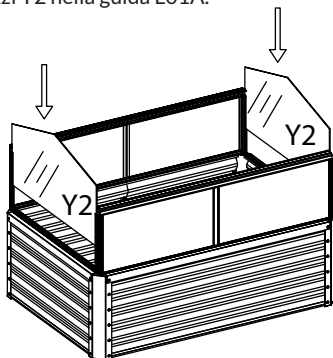

Inserire i pezzi Y2 nella guida L01A.

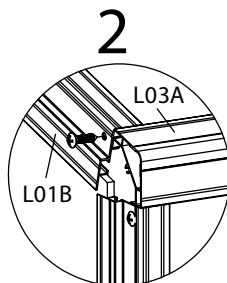
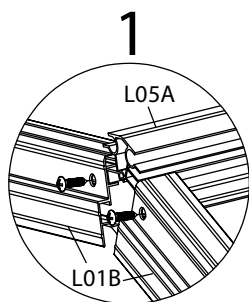
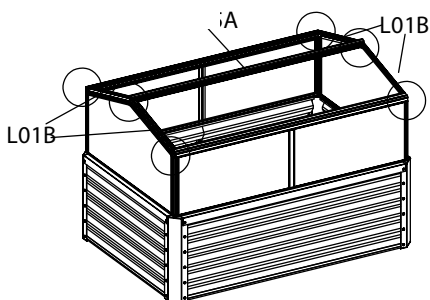

Fissare il pezzo L01B su L01A e L03A utilizzando una vite Z01.

Fissare il pezzo L05 su L01B con una vite Z01.



PZ.	NUM.	QTÀ.
	L04B	2
	S01 M5X10	4
	M01 M5	4

Inserire le due viti S01 in ogni pezzo L04B.

Fissare L04B su L03A e L05A con l'ausilio delle viti S01 e M01.

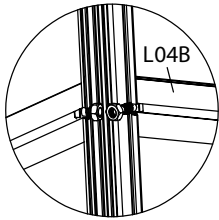
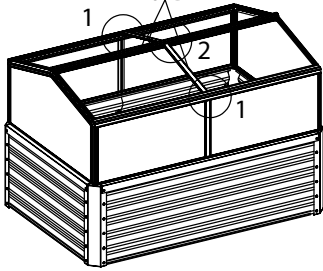
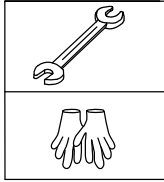

1

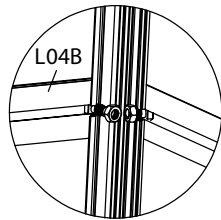



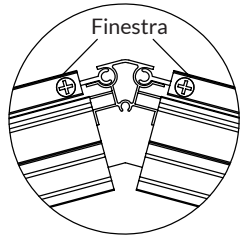
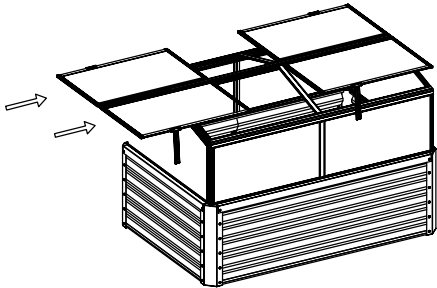

2

Inserire i pannelli delle finestre nelle guide L05A.



Finestra

PZ.	NUM.	QTÀ.
	J02	4
	J07	4
	Z01 M4X12D	6
	Z02 M4X8	8

