



blumfeldt

Havana

Pavillon mit Sitzgruppe
Gazebo with Lounge Set
Pergola avec salon
Pérgola con asientos
Gazebo con set lounge

10034772

10034773



Sehr geehrter Kunde,

wir gratulieren Ihnen zum Erwerb Ihres Produkts. Lesen Sie die folgenden Hinweise sorgfältig durch und befolgen Sie diese, um möglichen Schäden vorzubeugen. Für Schäden, die durch Missachtung der Hinweise und unsachgemäßen Gebrauch entstehen, übernehmen wir keine Haftung. Scannen Sie den folgenden QR-Code, um Zugriff auf die aktuellste Bedienungsanleitung und weitere Informationen rund um das Produkt zu erhalten:

**ARTIKEL**

Artikelnummer	10034772 10034773
---------------	----------------------

HINWEISE ZUR SICHERHEIT UND ZUM AUFBAU

- Der Aufbau erfordert mindestens zwei Personen. Eine Person kann Teile aufstellen und halten, während die andere Person mit Montagematerial und Werkzeugen arbeitet.
- Planen Sie im Voraus. Beobachten Sie das Wetter. Stellen Sie sicher, dass der Aufbau an einem trockenen, windstillen Tag stattfindet. Versuchen Sie das Gerüst nicht bei Wind aufzustellen, da es zu einer Personenverletzung kommen kann.
- Das Gerüst muss auf einer ebenen Fläche aufgestellt werden. Achten Sie darauf, dass der Untergrund nicht nass oder schlammig ist.
- Lassen Sie sich reichlich Zeit. Eile verursacht oft Fehler und erfordert den Neuaufbau eines falsch aufgebauten Gerüsts. Halten Sie das richtige Werkzeug bereit.
- Tragen Sie Schutzkleidung.
- Am besten legen Sie vor dem Beginn des Aufbaus alle Teile zurecht und überprüfen, ob alles da ist. Falls die Gefahr besteht, dass Teile zerkratzen, legen Sie Decken oder Kunststoffplanen darunter.
- Ziehen Sie alle Muttern und Schrauben fest. Vergessen Sie keine Schrauben.

Dear Customer,

Congratulations on purchasing this product. Please read the following instructions carefully and follow them to prevent possible damages. We assume no liability for damage caused by disregard of the instructions and improper use. Scan the QR code to get access to the latest user manual and more product information.



ITEM

Item number	10034772 10034773
-------------	----------------------

NOTES ON SAFETY AND CONSTRUCTION

- The assembly requires at least 2 persons. One person can position parts while the other is able to handle the fasteners and the tools.
- Plan ahead. Watch the weather. Please be sure the day you select for installation is dry and calm. Do not attempt to assemble your swing in windy weather because of risk of personal injury.
- The framework must be assembled on a level surface. Mind wet or muddy ground.
- Allow plenty of time. Rushing often causes errors and the re-doing of incorrect assemblies. Have the right tools to hand.
- Safety clothing as recommended.
- Ideally lay out the parts and check that all are present before commencing construction. Lay on cloths or plastic sheets if there is any risk of scratching the parts.
- Tighten all nuts carefully, being sure not to miss any.

Chère cliente, cher client,

Toutes nos félicitations pour l'acquisition de ce nouvel produit. Veuillez lire attentivement et respecter les instructions de ce mode d'emploi afin d'éviter d'éventuels dommages. Nous ne saurions être tenus pour responsables des dommages dus au non-respect des consignes et à la mauvaise utilisation de l'appareil. Scannez le QR-Code pour obtenir la dernière version du mode d'emploi et des informations supplémentaires concernant le produit.

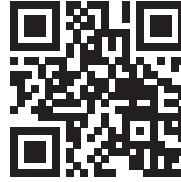

ARTICLE

Numéro d'article	10034772
	10034773

CONSIGNES DE SÉCURITÉ ET D'ASSEMBLAGE

- Le montage requiert au moins deux personnes. Une personne peut installer et tenir les pièces tandis que l'autre travaille avec les matériaux et outils d'assemblage.
- Planifiez le montage. Surveillez la météo. Procédez à l'assemblage par temps sec et sans vent. N'essayez pas d'installer la structure par temps venteux, car cela peut entraîner des blessures.
- La structure doit être placée sur une surface plane. Assurez-vous que la surface n'est pas mouillée ou boueuse.
- Prenez votre temps. La précipitation conduit souvent à des erreurs et nécessite de recommencer le montage de la structure mal installée. Préparez les bons outils.
- Portez des vêtements de protection.
- Il est préférable de mettre toutes les pièces en place et de vérifier que rien ne manque avant de commencer l'assemblage. S'il y a un risque de rayer les pièces, placez des couvertures ou des bâches en plastique en dessous.
- Serrez tous les écrous et boulons. N'oubliez aucune vis.

Estimado cliente,

Le felicitamos por la adquisición de este producto. Lea atentamente las siguientes instrucciones y sígalas para evitar posibles daños. No asumimos ninguna responsabilidad por los daños causados por el incumplimiento de las instrucciones y el uso inadecuado. Escanee el siguiente código QR para obtener acceso a la última guía del usuario y más información sobre el producto.



ARTÍCULO

Número del artículo	10034772
	10034773

INDICACIONES DE SEGURIDAD Y DE MONTAJE

- El montaje deberá ser realizado por al menos dos personas. Una persona se ocupará de colocar y sostener las piezas, mientras que la otra trabajará con el material de montaje y las herramientas.
- Realice la planificación con antelación. Tenga en cuenta la previsión meteorológica. Asegúrese de realizar el montaje en un día seco y sin viento. No intente instalar la estructura con viento, podrían producirse daños personales.
- La estructura deberá colocarse en una superficie plana. Asegúrese de que el suelo no esté mojado ni embarrado.
- Tómese el tiempo necesario. Las prisas suelen provocar fallos, que requerirán volver a montar desde cero una estructura mal instalada. Tenga a mano las herramientas adecuadas.
- Utilice ropa de protección.
- Se recomienda presentar todas las piezas antes de comenzar el montaje para comprobar que no falte ninguna. Si existe riesgo de que las piezas arañen la superficie, coloque una manta o lonas plásticas debajo.
- Apriete bien todos los tornillos y tuercas. No se olvide de ningún tornillo.

Gentile cliente,

La ringraziamo per aver acquistato il prodotto. La preghiamo di leggere attentamente le seguenti istruzioni per l'uso e di seguirle per evitare possibili danni. Non ci assumiamo alcuna responsabilità per danni scaturiti da una mancata osservazione delle avvertenze di sicurezza e da un uso improprio del dispositivo. Scansionare il codice QR seguente, per accedere al manuale d'uso più attuale e per ricevere informazioni sul prodotto.



ARTICOLO











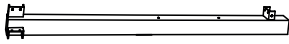

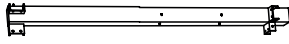

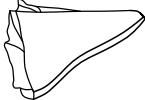





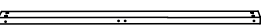

Articolo numero	10034772 10034773
-----------------	----------------------

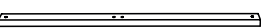
AVVERTENZE PER LA SICUREZZA E L'INSTALLAZIONE

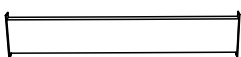
- Il montaggio richiede la presenza di almeno 2 persone. Una persona può montare i pezzi e tenerli, mentre l'altra si occupa del materiale di montaggio e degli attrezzi.
- Pianificare il montaggio in anticipo e controllare le condizioni meteo. Assicurarsi di eseguire il montaggio in un giorno asciutto e senza vento. Non montare la struttura quando c'è vento, dato che ci si potrebbe fare male.
- La struttura deve essere montata su una superficie piana. Assicurarsi che il suolo non sia bagnato o fangoso.
- Prendersi tempo per il montaggio. La fretta causa spesso errori e richiede un nuovo montaggio se la struttura viene installata erroneamente. Tenere a portata di mano gli attrezzi giusti.
- Indossare abbigliamento protettivo.
- Prima di iniziare il montaggio, posizionare i pezzi e verificare se ci sono tutti. Se i pezzi rischiano di graffiarsi, usare come fondo di appoggio delle coperte o dei teli di plastica.
- Stringere bene tutti i dadi e le viti. Non dimenticare nessuna vite.

ZUSAMMENBAU ASSEMBLY / ASSEMBLAGE / MONTAJE / MONTAGGIO

Teile Parts Pièces Parties Parti

A		1	J		1
B		1	K		1
C		1	L		2
D		1	M1	 M8*20mm	36
			M2	 M6*20mm	12
E		2	N1	 M8	1
			N2	 M6	1
F1		3	P	 $\phi 16*8.4\text{mm}$	36
F2		1	Q		12
F3		1	R		4
G		2	S1		4
			S2		6
H		5	T		4
					

Montageübersicht *Assembly overview / Aperçu du montage / Resumen del montaje /
Panoramica del montaggio*

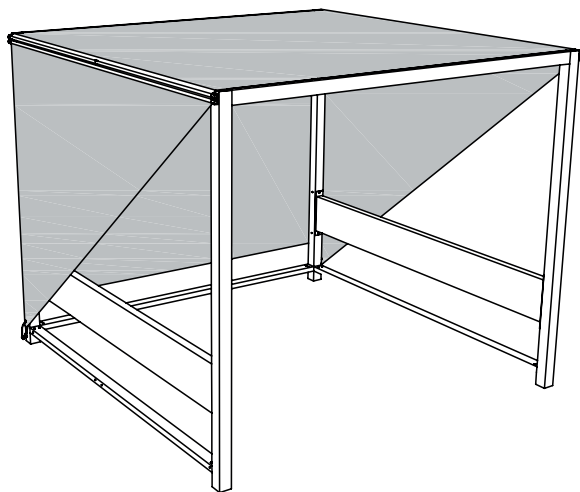
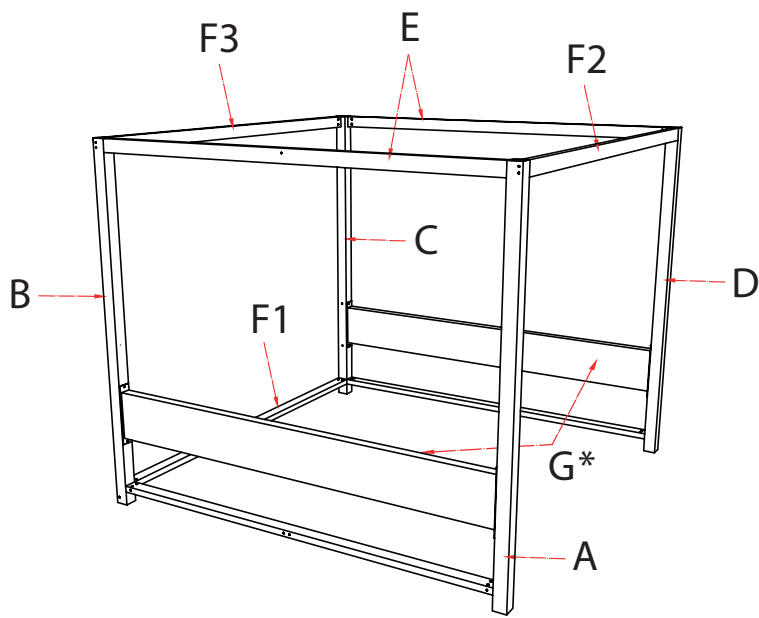

*** Erklärung zu Teil G, siehe: Montage-Varianten (Teil G)**

*Explanation on part G, see: Assembly variants (part G) / Explication de la partie G, voir :
Variantes de montage (partie G) / Para aclaraciones sobre la parte G, consulte: Variantes
de montaje (parte G) / Spiegazione della parte G, vedi: Varianti di montaggio (parte G)*

Montage-Varianten (Teil G) *Assembly variants (part G) / Variantes de montage (partie G) / Variantes de montaje (parte G) /= Varianti di montaggio (parte G)*



Teile G an den Seitenwänden, einander gegenüber liegend, montiert.

Parts G mounted on the side walls, facing each other.

Les parties G sont montées sur les parois latérales, en face les unes des autres.

Partes G montadas en las paredes laterales opuestas entre sí.

Parti G montate sulle pareti laterali, l'una di fronte all'altra.



Teile G an einer Seitenwand und an der Rückwand, eine Ecke bildend, montiert.

Parts G mounted on a side wall and on the rear wall, forming a corner.

Les parties G sont montées sur une paroi latérale et sur la paroi arrière, formant un coin.

Partes G montadas en una pared lateral y en la pared trasera formando una esquina.

Le parti G montate su una parete laterale e sulla parete posteriore formano un angolo.



Hinweise zur Montage

1. Die Streben B und C sollten so montiert werden (Schritt 1), dass sich die 2 Schraubenlöcher jeweils oben an den Außenseiten des Pavillons (linke und rechte Außenseite) befinden. Die Schraubenlöcher dienen der Montage der Clips (Q), siehe Schritt 5.
2. An den waagerechten Streben (E, F1, F3) befinden sich jeweils 4 Schraubenlöcher auf einer Seite. Montieren Sie die Streben so, dass die Schraubenlöcher sich an der Außenseite des Pavillons befinden. Sie sind für eine mögliche zukünftige Erweiterung durch eine Holzpergola vorgesehen.

Notes on assembly

1. Struts B and C should be mounted (step 1) so that the 2 screw holes are located at the top of the outer sides of the pavilion (left and right outer side). The screw holes are used to mount the clips (Q), see step 5.
2. On the horizontal struts (E, F1, F3) there are 4 screw holes on each side. Mount the braces so that the screw holes are on the outside of the pavilion. They are intended for a possible future extension with a wooden pergola.

Notes sur le montage

1. Les montants B et C doivent être montés (étape 1) de manière à ce que les 2 trous de vis soient situés en haut des côtés extérieurs du pavillon (côté extérieur droit et gauche). Les trous de vis servent à monter les clips (Q), voir étape 5.
2. Les supports horizontaux (E, F1, F3) comprennent 4 trous de vis de chaque côté. Montez les supports de manière à ce que les trous de vis se trouvent à l'extérieur du pavillon. Ils sont destinés à une éventuelle extension future avec une pergola en bois.

Indicaciones sobre el montaje

1. Los pilares B y C deben montarse (paso 1) de modo que los 2 orificios para los tornillos queden orientados hacia arriba y en los lados exteriores de la pérgola (partes exteriores derecha e izquierda). Los orificios para los tornillos sirven para montar los acoples (Q). Véase paso 5.
2. En cada uno de los postes horizontales (E, F1, F3) encontrará 4 orificios para tornillos en uno de los lados. Monte los postes de modo que los orificios se orienten hacia la parte exterior de la pérgola. Están concebidos para una posible ampliación con una pérgola de madera.

Note per il montaggio

1. I montanti B e C devono essere montati (fase 1) in modo che i 2 fori per le viti si trovino nella parte superiore dei lati esterni del padiglione (lato esterno sinistro e destro). I fori per le viti vengono utilizzati per montare le clip (Q), vedi punto 5.
2. Sui montanti orizzontali (E, F1, F3) ci sono 4 fori per le viti su ogni lato. Montare i montanti in modo che i fori per le viti si trovino all'esterno del padiglione. Potranno essere utilizzati in futuro per un ampliamento con una pergola in legno.

1

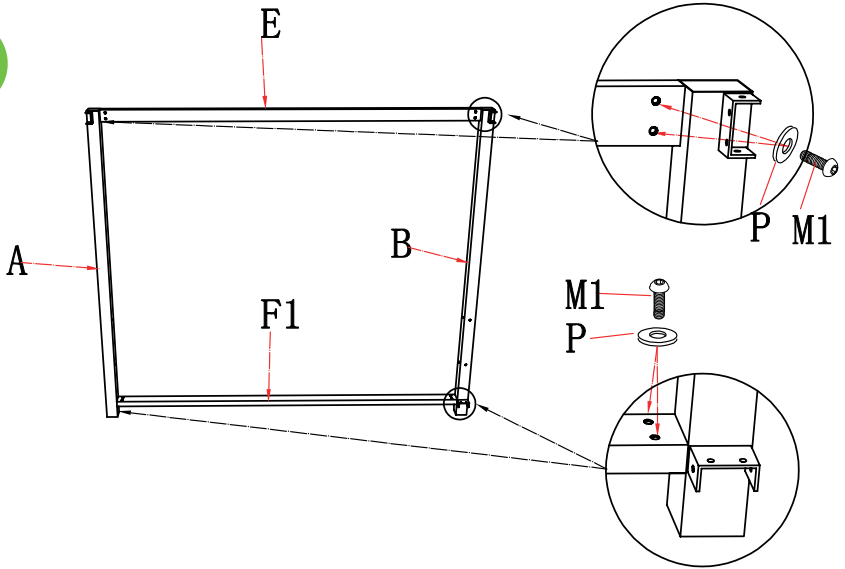

2

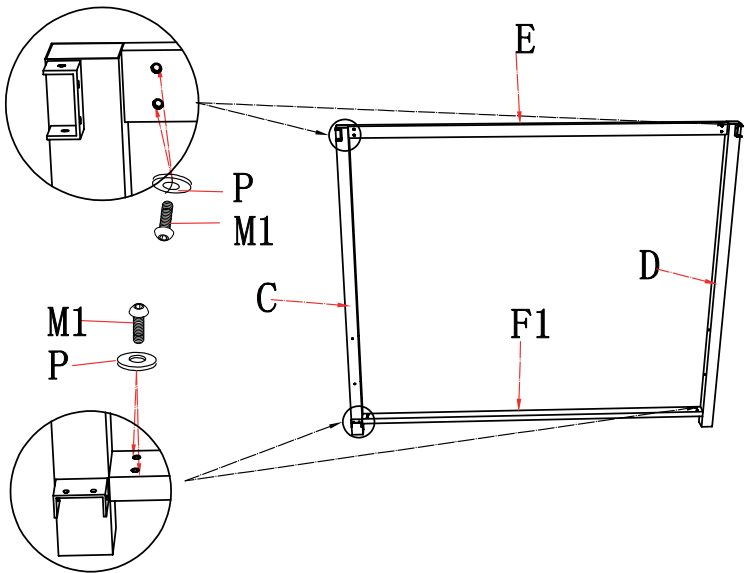

3

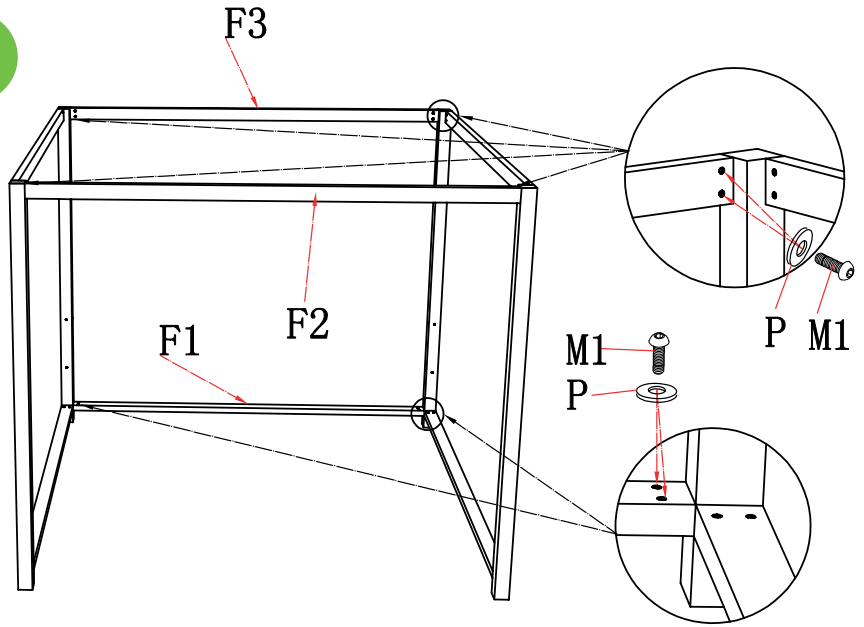

4

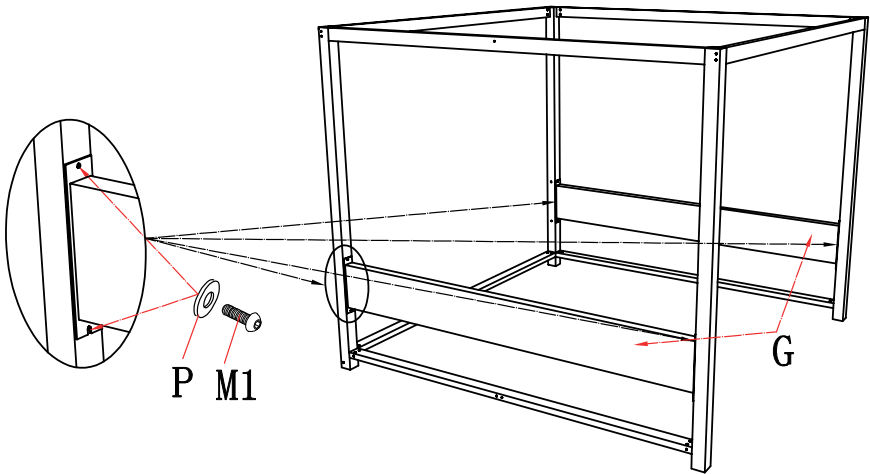

5

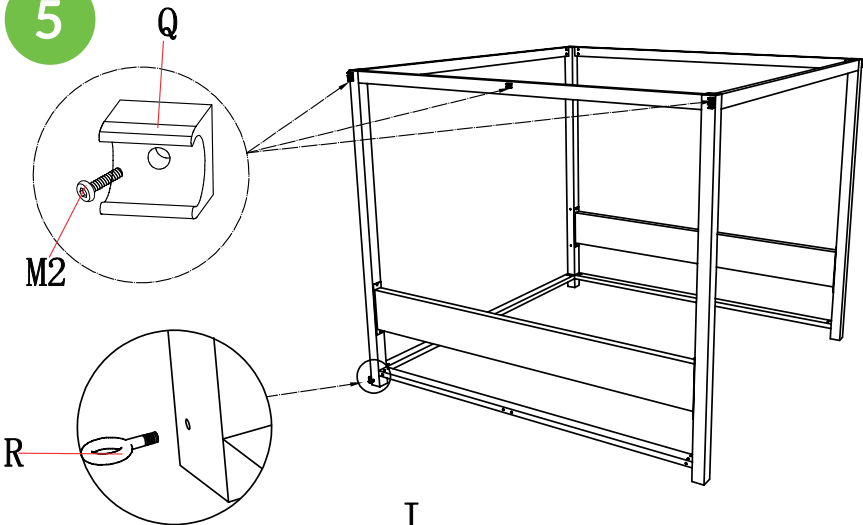

6

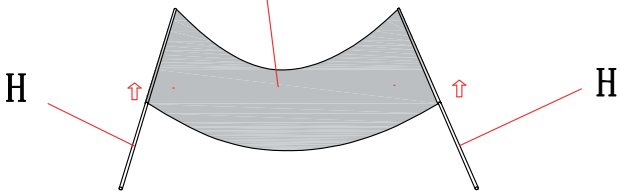

7

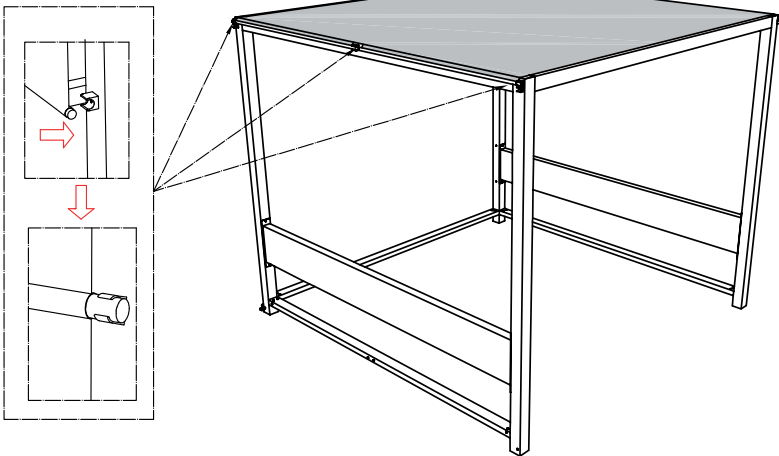

8

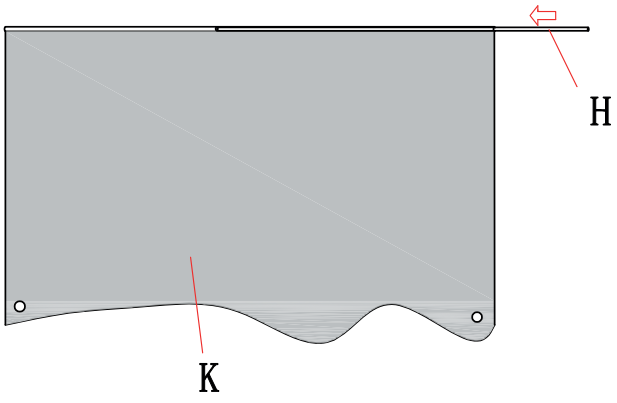

9

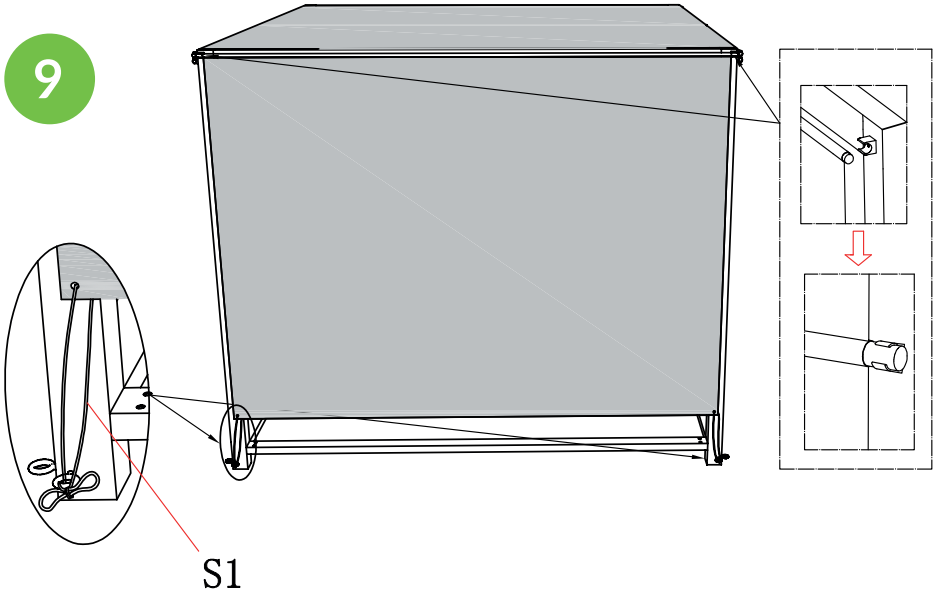

10

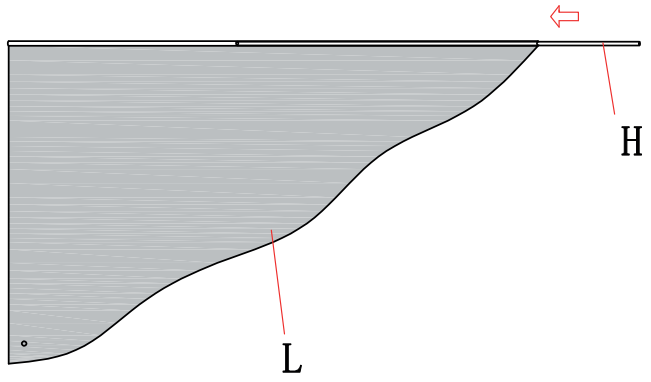

11

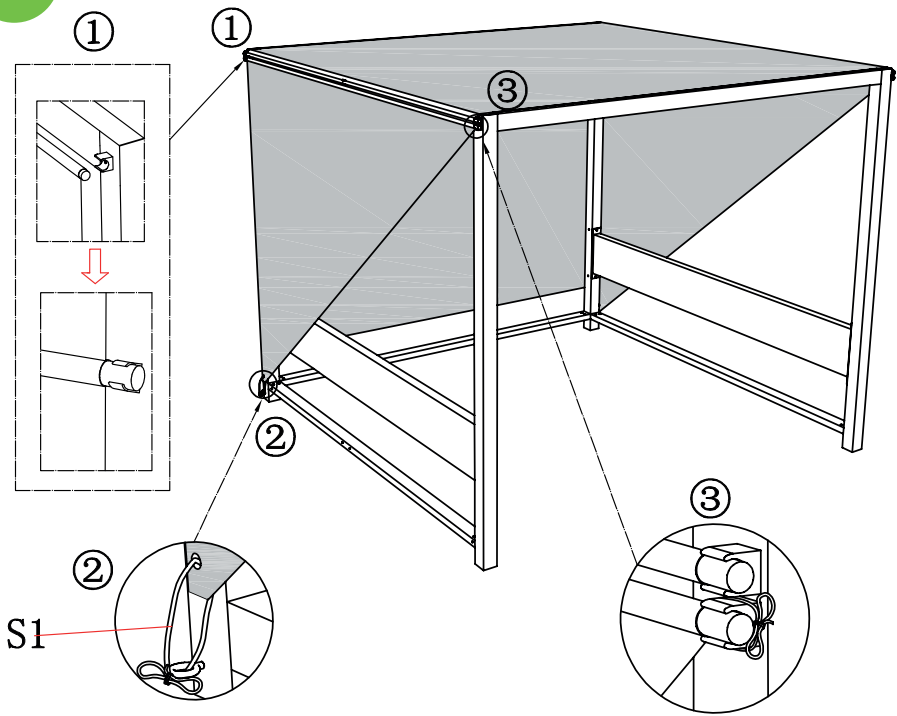

12

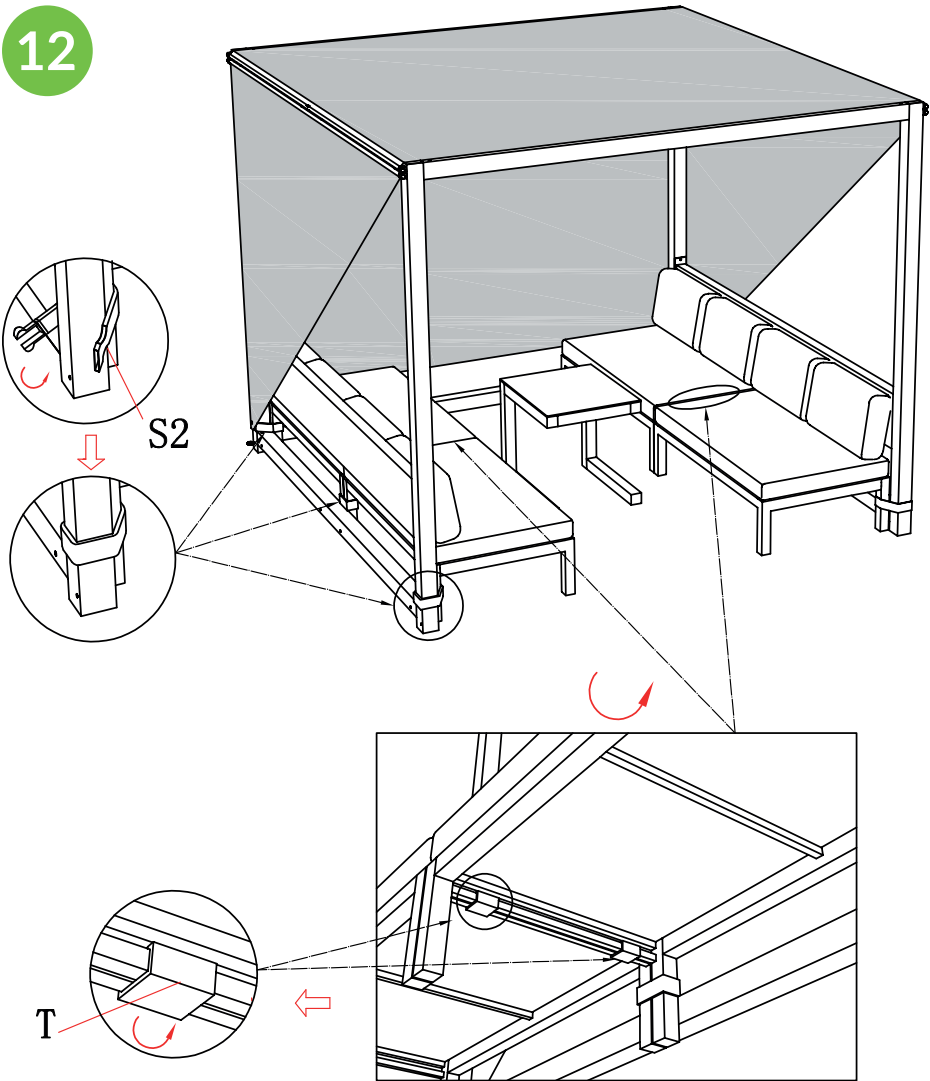

HERSTELLER

Manufacturer | Fabricante | Fabricant | Produttore

Chal-Tec GmbH, Wallstraße 16, 10179 Berlin, Deutschland (Germany).

IMPORTEUR FÜR GROSSBRITANNIEN

Importer for Great Britain | Importador para Gran Bretaña | Importateur pour la Grande Bretagne | Importatore per la Gran Bretagna

Berlin Brands Group UK Ltd
PO Box 1145
Oxford, OX1 9UW
United Kingdom

