



blumfeldt



Palermo

Terassenschaukel
Porch Swing
Balancelle de terrasse
Columpio de jardín
Dondolo da giardino

10034774

Artikelnummer	10034774
---------------	----------

Hersteller:

Chal-Tec GmbH, Wallstraße 16, 10179 Berlin, Deutschland.

HINWEISE ZUR SICHERHEIT UND ZUM AUFBAU

- Der Aufbau erfordert mindestens zwei Personen. Eine Person kann Teile aufstellen und halten, während die andere Person mit Montagematerial und Werkzeugen arbeitet.
- Planen Sie im Voraus. Beobachten Sie das Wetter. Stellen Sie sicher, dass der Aufbau an einem trockenen windstillen Tag stattfindet. Versuchen Sie das Gerüst nicht bei Wind aufzustellen, da es zu einer Personenverletzung kommen kann.
- Das Gerüst muss auf einer ebenen Fläche aufgestellt werden. Achten Sie darauf, dass der Untergrund nicht nass oder schlammig ist.
- Lassen Sie sich reichlich Zeit. Eile verursacht oft Fehler und erfordert den Neuaufbau eines falsch aufgebauten Gerüsts. Halten Sie das richtige Werkzeug bereit.
- Tragen Sie Schutzkleidung.
- Am besten legen Sie vor dem Beginn des Aufbaus alle Teile zurecht und überprüfen, ob alles da ist. Falls die Gefahr besteht, dass Teile zerkratzen, legen Sie Decken oder Kunststoffplanen darunter.
- Ziehen Sie alle Muttern und Schrauben fest. Vergessen Sie keine Schrauben.

Item number	10034774
-------------	----------

Manufacturer:

Chal-Tec GmbH Wallstraße 16 10179 Berlin, Germany

NOTES ON SAFETY AND CONSTRUCTION

- The assembly requires at least 2 persons. One person can position parts while the other is able to handle the fasteners and the tools.
- Plan ahead. Watch the weather. Please be sure the day you select for installation is dry and calm. Do not attempt to assemble your swing in windy weather because of risk of personal injury.
- The framework must be assembled on a level surface. Mind wet or muddy ground.
- Allow plenty of time. Rushing often causes errors and the re-doing of incorrect assemblies. Have the right tools to hand.
- Safety clothing as recommended.
- Ideally lay out the parts and check that all are present before commencing construction. Lay on cloths or plastic sheets if there is any risk of scratching the parts.
- Tighten all nuts carefully, being sure not to miss any.

Numéro d'article	10034774
------------------	----------

Fabricant:

Chal-Tec GmbH, Wallstraße 16, 10179 Berlin, Allemagne.

CONSIGNES DE SÉCURITÉ ET D'INSTALLATION

- L'installation nécessite au moins deux personnes. Une personne peut installer et tenir les éléments tandis que l'autre s'occupe des matériaux et outils d'assemblage
- Programmez le montage. Surveillez la météo. Assurez-vous que l'installation a lieu un jour sec et sans vent. N'essayez pas d'installer la structure en présence de vent, car cela peut entraîner des blessures.
- La structure doit être placée sur une surface plane. Assurez-vous que la surface n'est pas mouillée ou boueuse.
- Prenez votre temps. La précipitation provoque souvent des erreurs et nécessite la reconstruction d'une structure mal installée. Préparez le bon outil.
- Portez des vêtements de protection.
- Le mieux est de mettre toutes les pièces en place et de vérifier qu'elles sont toutes présentes avant de commencer l'assemblage. Si les pièces risquent de se rayer, placez des couvertures ou des bâches en plastique en dessous.
- Serrez tous les écrous et boulons. N'oubliez aucune vis.

Número de artículo	10034774
--------------------	----------

Fabricante:

Chal-Tec GmbH, Wallstraße 16, 10179 Berlín, Alemania.

NOTAS SOBRE SEGURIDAD E INSTALACIÓN

- Son necesarias al menos dos personas para el montaje. Una persona puede armar y sujetar partes mientras la otra persona trabaja con material y herramientas de montaje.
- Planee con anticipación. Observe el clima. Asegúrese de que el montaje se realice en un día seco y con poco viento. No intente armar el soporte en condiciones de viento, ya que las personas pueden resultar heridas.
- El soporte debe ser colocado en una superficie plana. Asegúrese de que el sustrato no esté húmedo ni embarrado.
- Tómese su tiempo. La prisa a menudo causa errores y requiere realizar el montaje del soporte nuevamente. Tenga listas las herramientas necesarias.
- Use ropa de trabajo que lo proteja.
- Lo mejor es desplegar todas las piezas antes de empezar el montaje y comprobar que todo está en su sitio. Si existe riesgo de rayar partes, coloque plástico debajo.
- Apriete todos los tornillos y tuercas, no olvide ninguno

Numero articolo	10034774
-----------------	----------

Produttore:











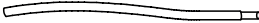

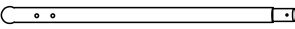
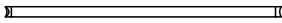
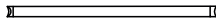
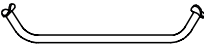
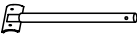
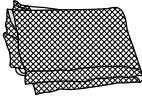
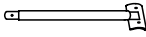
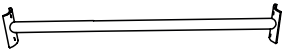

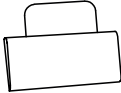
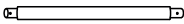

Chal-Tec GmbH, Wallstraße 16, 10179 Berlino, Germania.

AVVERTENZE DI SICUREZZA E ISTRUZIONI PER IL MONTAGGIO

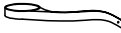
- Il montaggio richiede la presenza di almeno 2 persone. Una persona può montare i pezzi e mantenerli, mentre l'altra si occupa del materiale di montaggio e degli attrezzi.
- Il montaggio va pianificato in anticipo e si consiglia di controllare le previsioni del tempo. Assicurarsi di eseguire il montaggio in un giorno asciutto e senza vento. Non montare la struttura quando c'è vento, dato che ci si potrebbe ferire.
- La struttura va montata su una superficie piana. Assicurarsi che il suolo non sia bagnato o fangoso.
- Prendersi tempo per il montaggio. La fretta causa spesso errori e richiede un nuovo montaggio se la struttura viene installata erroneamente. Tenere a portata di mano gli attrezzi giusti.
- Indossare abbigliamento di protezione.
- Prima di iniziare il montaggio collezionare i pezzi e verificare se ci sono tutti. Se i pezzi rischiano di graffiarsi, appoggiarli su un tappeto o telone di plastica.
- Stringere bene tutti i dadi e le viti. Non dimenticare nessuna vite.

ZUSAMMENBAU ASSEMBLY ASSEMBLAGE MONTAJE MONTAGGIO

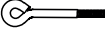
Teile *Parts Parts Parties Parti*

A		2	J		2
B		2	K		2
C		4	L		1
D		2	M		1
E1		2	N		1
E2		2			
F		2	P		1
G		2	Q		2
H		1	R		2
S1	 M8*70	8	T1		2
S2	 M8*65	8	T2		2
S3	 M8*50	2	T3		1
S4	 M6*20	3	W1	 M8	1
S5		2	W2	 M8	1
S6		2			
S7		8			

1

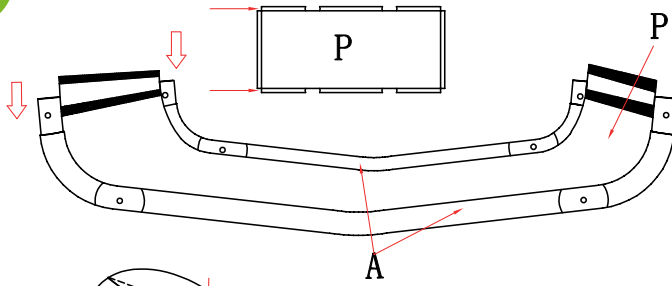

2

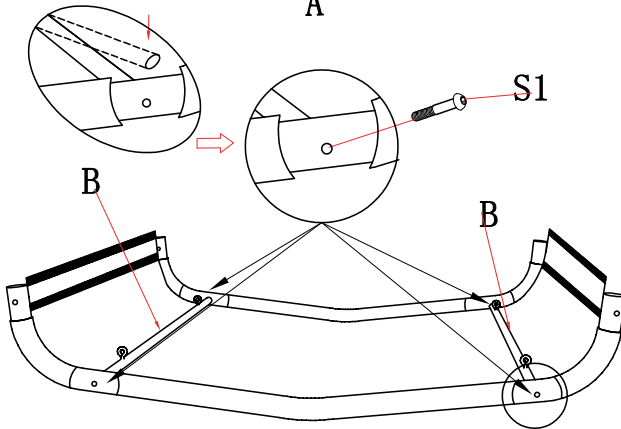

3

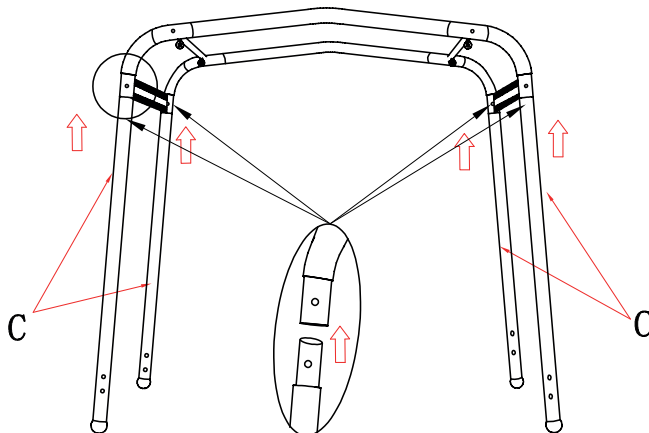

4

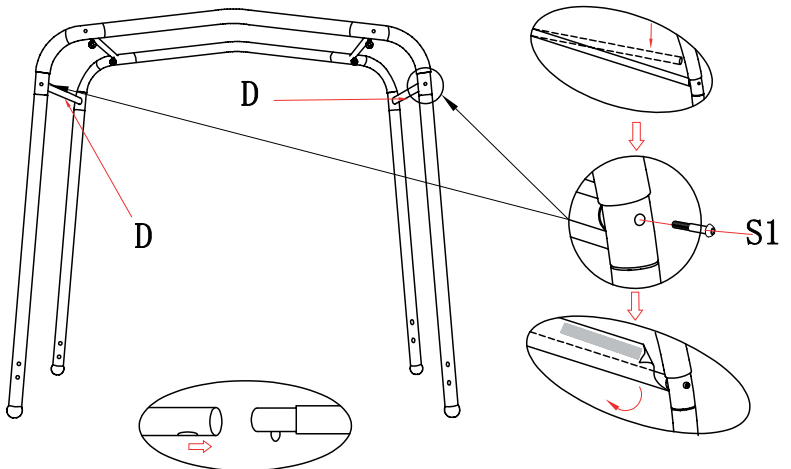

5

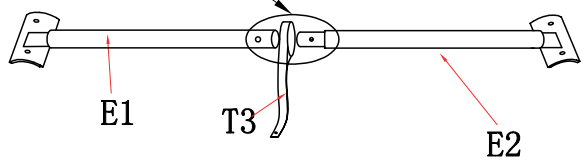

6

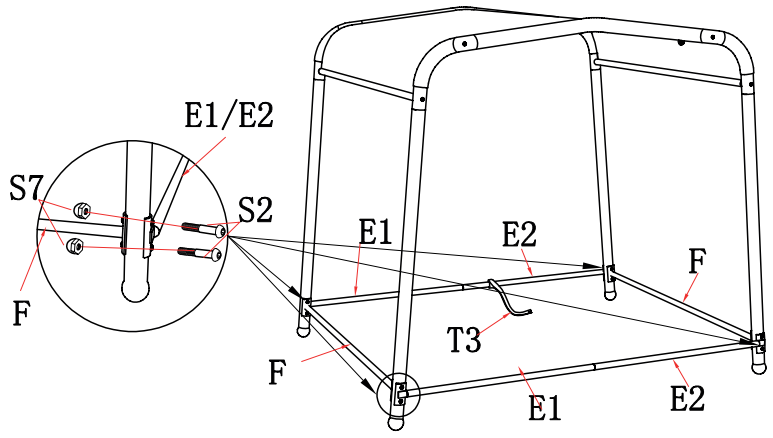

7

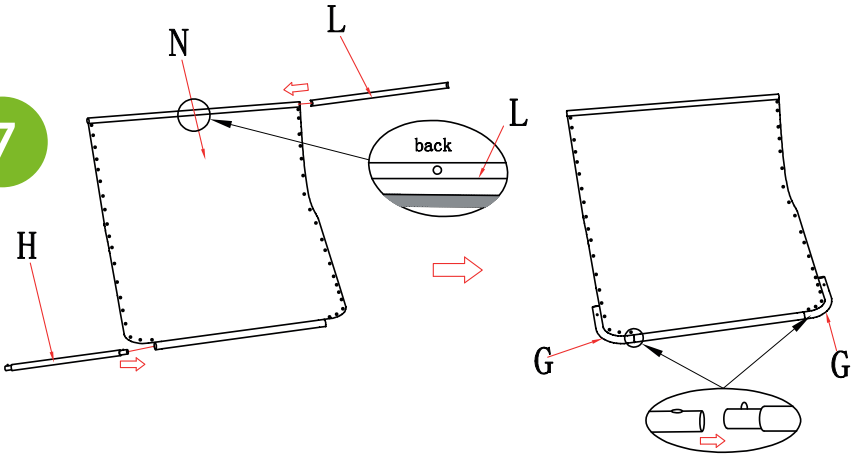

8

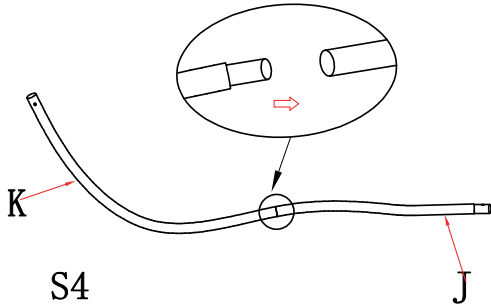

9

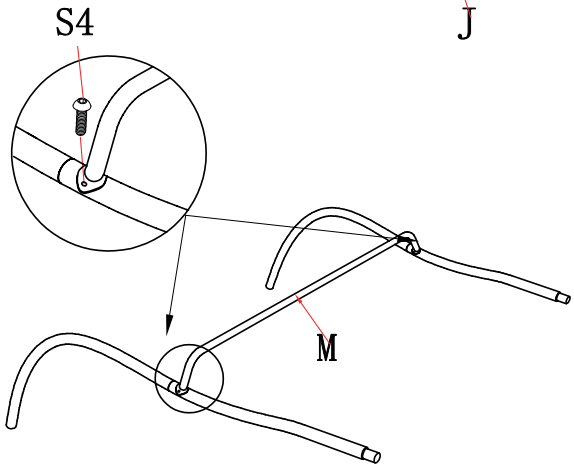

10

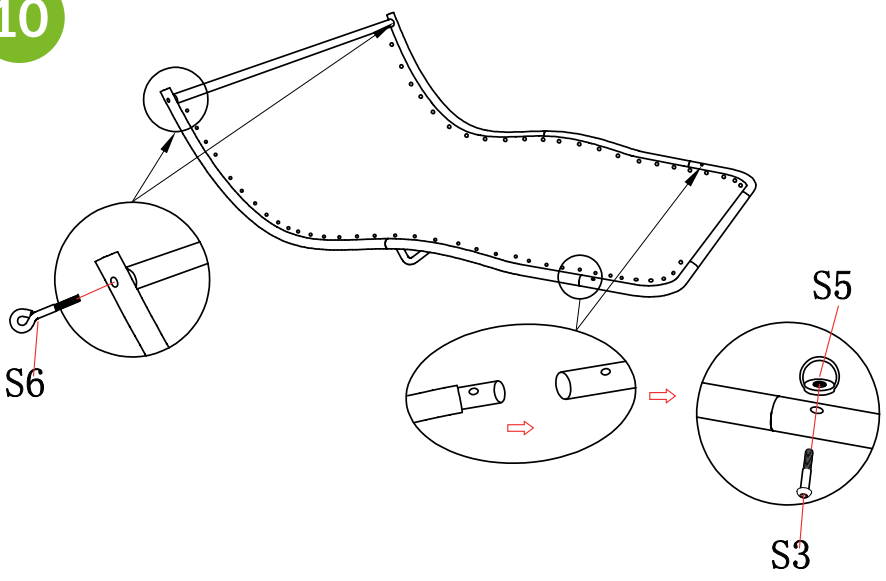

11

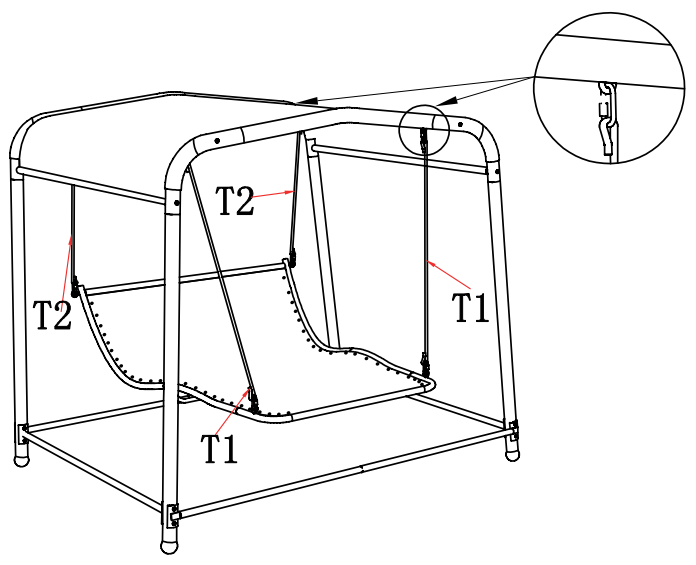

12

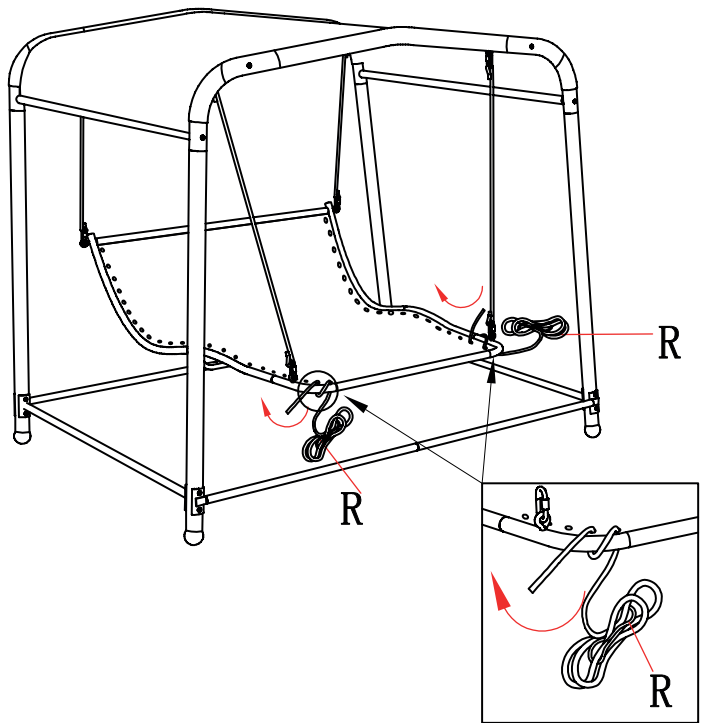

13

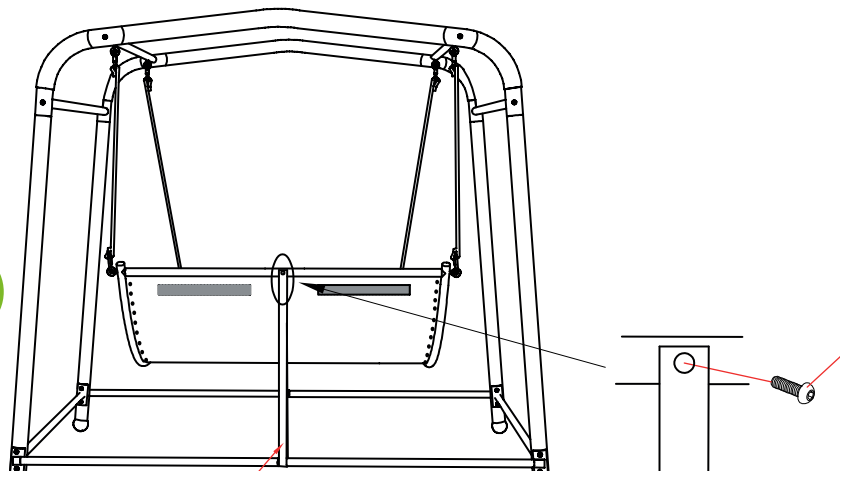

14

