



blumfeldt



Menorca Roll

Serviertisch mit Rollen

Tea Trolley Table

Desserte à roulettes

Mesa de servicio con ruedas

Carrello da portata con ruote

10034817

ARTIKEL

Artikelnummer	10034817
---------------	----------

HINWEISE ZUR SICHERHEIT UND ZUR BENUTZUNG

- Lassen Sie keine leeren Gläser auf dem Tisch stehen.
- Stellen Sie Gläser nicht direkt auf den Tisch. Verwenden Sie Untersetzer.
- Nicht auf den Tisch setzen.
- Nicht auf den Tisch stellen.
- Nicht ohne Unterlage schneiden.
- Aufrecht lagern.

PFLEGEHINWEISE

- Waschen Sie Verunreinigungen, die Verfärbungen verursachen, sofort ab.
- Verwenden Sie ein feuchtes Tuch und pH-neutrale Seife.
- Steht der Tisch unter Bäumen, decken Sie den Tisch ab, wenn er nicht verwendet wird.
- Reinigen Sie den Tisch, bevor Sie ihn für den Winter einlagern.

HERSTELLER & IMPORTEUR (UK)

Hersteller:

Chal-Tec GmbH, Wallstraße 16, 10179 Berlin, Deutschland.

Importeur für Großbritannien:

Berlin Brands Group UK Ltd
PO Box 1145
Oxford, OX1 9UW
United Kingdom

ITEM

Item number	10034817
-------------	----------

NOTES ON SAFETY AND USE

- Do not leave empty glasses on the table.
- Do not put glasses directly on the table surface. Use coasters.
- Do not sit on the table.
- Do not stand on the table.
- Do not cut without underlay.
- Store upright.

CARE INSTRUCTIONS

- Wash off any dirt that cause discolouration immediately.
- Use a damp cloth and pH-neutral soap.
- If the table is under trees, cover the table when not in use.
- Clean the table before storing it for the winter.

MANUFACTURER & IMPORTER (UK)

Manufacturer:

Chal-Tec GmbH, Wallstrasse 16, 10179 Berlin, Germany.

Importer for Great Britain:

Berlin Brands Group UK Ltd

PO Box 1145

Oxford, OX1 9UW

United Kingdom

ARTICLE

Numéro d'article	10034817
------------------	----------

CONSIGNES DE SÉCURITÉ ET D'UTILISATION

- Ne laissez pas de verres vides sur la table.
- Ne posez pas de verres directement sur la table. Utilisez des sous-verres.
- Ne vous asseyez pas sur la table.
- Ne montez pas sur la table.
- Ne découpez pas sans tapis de coupe.
- Rangez la table debout.

CONSIGNES D'ENTRETIEN

- Laver immédiatement les taches qui provoquent une décoloration.
- Utilisez un chiffon humide et un savon au pH neutre.
- Si la table est sous les arbres, couvrez-la lorsque vous ne l'utilisez pas.
- Nettoyez la table avant de la ranger pour l'hiver.

FABRICANT ET IMPORTATEUR (UK)

Fabricant :

Chal-Tec GmbH, Wallstraße 16, 10179 Berlin, Allemagne.

Importateur pour la Grande Bretagne :

Berlin Brands Group UK Ltd

PO Box 1145

Oxford, OX1 9UW

United Kingdom

ARTÍCULO

Número del artículo	10034817
---------------------	----------

INFORMACIÓN SOBRE SEGURIDAD Y USO

- No deje vasos vacíos en la mesa.
- No coloque los vasos directamente sobre la mesa. Use los posavasos.
- No se siente sobre la mesa.
- No se ponga de pie sobre la mesa.
- No corte sin tabla de cortar
- Almacénela en posición vertical.

INSTRUCCIONES DE CUIDADO

- Lave inmediatamente cualquier impureza que cause decoloración.
- Use un paño húmedo y un jabón de pH neutro.
- Si la mesa está debajo de los árboles, cúbrala cuando no se utilice.
- Limpie la mesa antes de guardarla para el invierno.

FABRICANTE E IMPORTADOR (REINO UNIDO)

Fabricante:

Chal-Tec GmbH, Wallstraße 16, 10179 Berlín, Alemania.

Importador para Gran Bretaña:

Berlin Brands Group UK Ltd
PO Box 1145
Oxford, OX1 9UW
United Kingdom

ARTICOLO

Numero articolo	10034817
-----------------	----------

AVVERTENZE DI SICUREZZA E UTILIZZO

- Non lasciare bicchieri vuoti sul tavolo.
- Non posizionare i bicchieri direttamente sul tavolo, ma utilizzare sottobicchieri.
- Non sedersi sul tavolo.
- Non appoggiarsi al tavolo.
- Non tagliarci sopra senza prima rivestire il tavolo.
- Riporre il tavolo in posizione eretta.

MANUTENZIONE

- Pulire subito qualsiasi tipo di sporco che potrebbe alterare il colore.
- Utilizzare un panno umido e del sapone neutro.
- Se il tavolo si trova sotto a degli alberi, coprirlo quando non viene utilizzato.
- Pulire il tavolo prima di riporlo per l'inverno.

PRODUTTORE E IMPORTATORE (UK)

Produttore:

Chal-Tec GmbH, Wallstraße 16, 10179 Berlino, Germania.

Importatore per la Gran Bretagna:

Berlin Brands Group UK Ltd







PO Box 1145







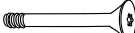

Oxford, OX1 9UW

United Kingdom

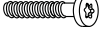
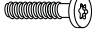
ZUSAMMENBAU ASSEMBLY ASSEMBLAGE MONTAJE MONTAGGIO

Teile Parts Pièces Parties Parti

A		2
B		1
C		1
D		1
E		1
F		2
G		4

H	 M8X55mm	2
I	 M6X48mm	8
J	 M6X32mm	4
K	 M6X25mm	4
L	 M6X15mm	4
M	 M8	2
N	 ø6mm	20
O	 T25 T30	1
P	 M8	1
Q	 ø6mm	8

Montageschritte Assembly Steps Etapes du montage Pasos del montaje Fasi montaggio

1

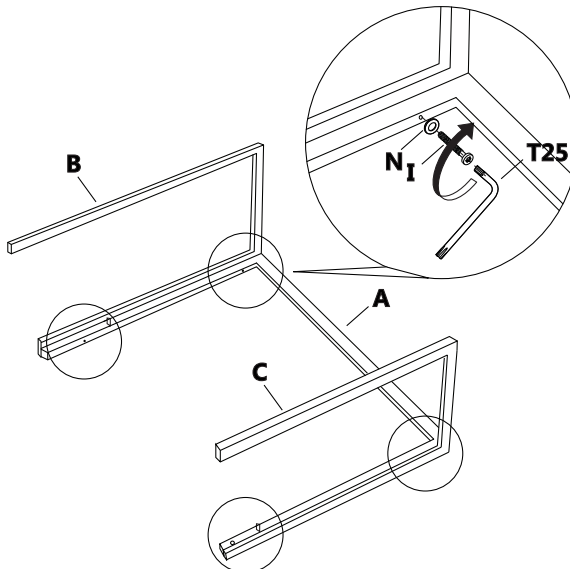

2

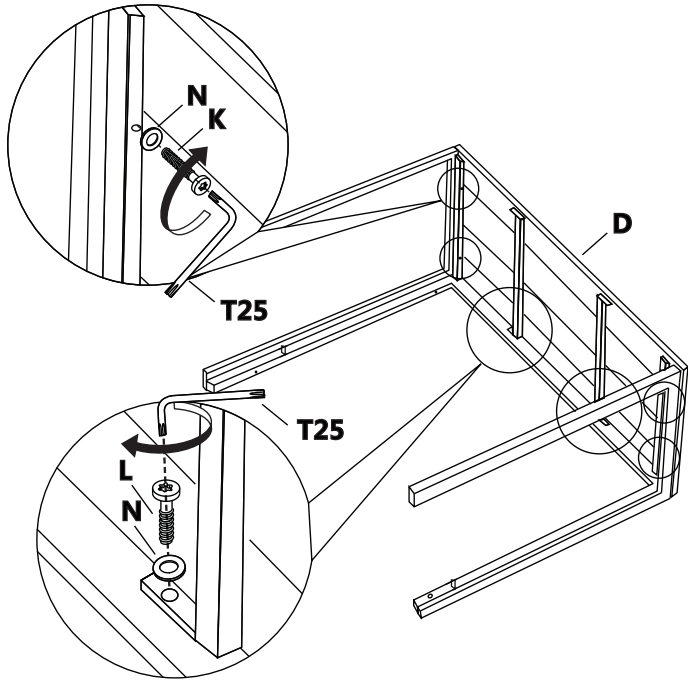

3

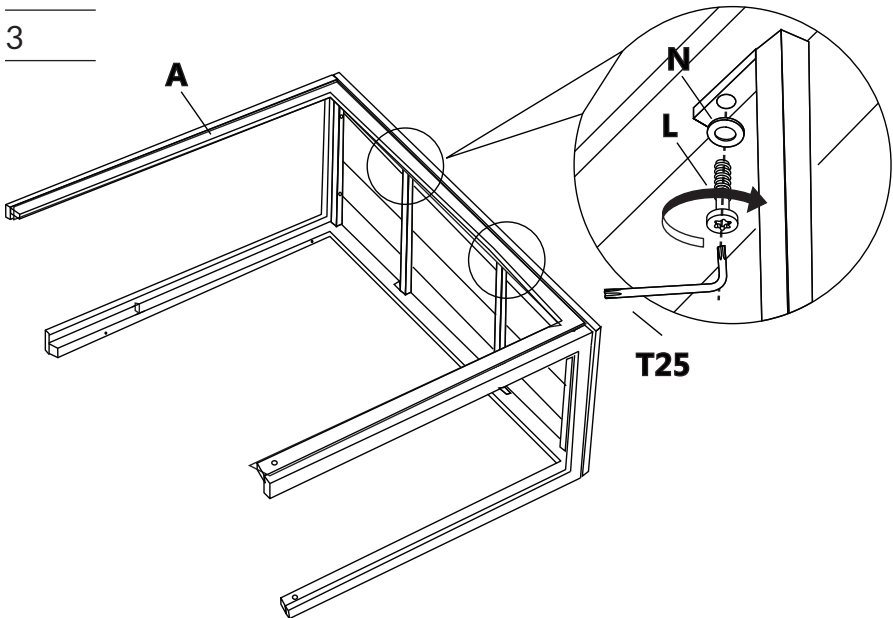

4

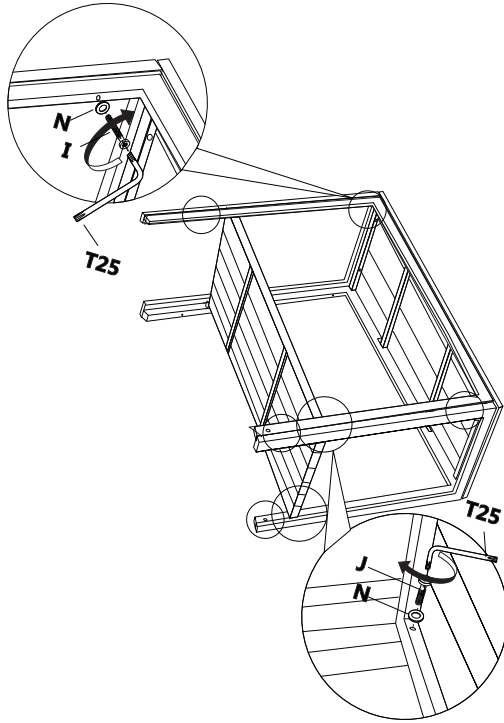

5

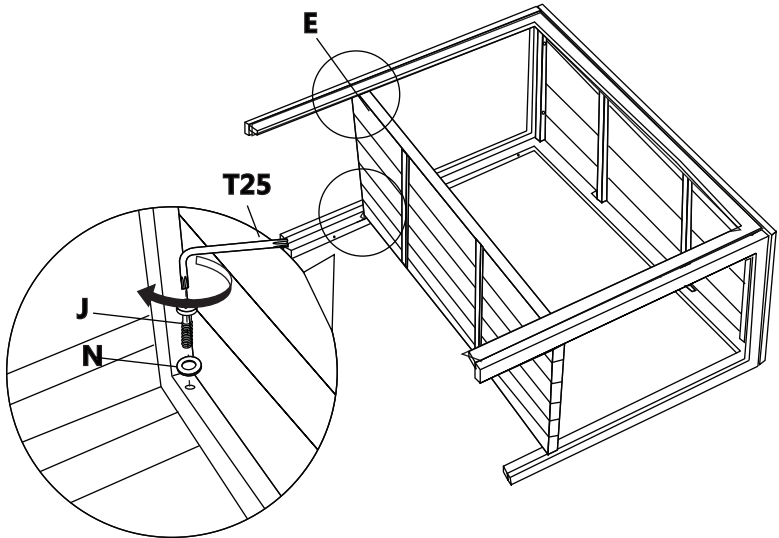

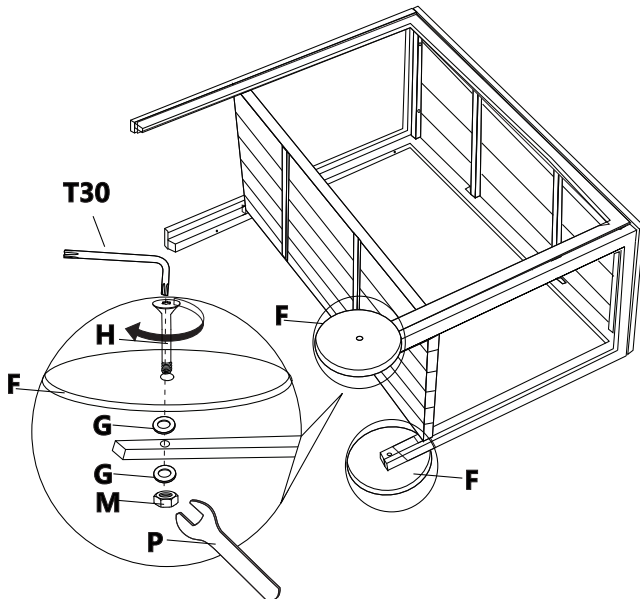
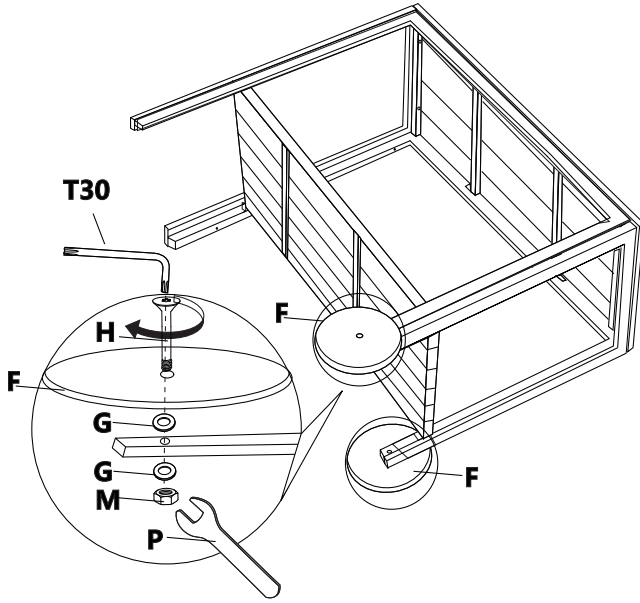



blumfeldt

