

# STUDIO FRAME II

Kamingehäuse  
Fireplace housing  
Marco para chimenea  
Insert de cheminée  
Cornice per caminetto

10035404



COMFORTING  
OMFORTING  
FORTINGCOI  
TINGCOMFO  
COMFORTING  
OMFORTING  
FORTINGCOI  
TINGCOMFO

**KLARSTEIN**

[www.klarstein.com](http://www.klarstein.com)



**Sehr geehrter Kunde,**

wir gratulieren Ihnen zum Erwerb Ihres Gerätes. Lesen Sie die folgenden Hinweise sorgfältig durch und befolgen Sie diese, um möglichen Schäden vorzubeugen. Für Schäden, die durch Missachtung der Hinweise und unsachgemäßen Gebrauch entstehen, übernehmen wir keine Haftung. Scannen Sie den folgenden QR-Code, um Zugriff auf die aktuellste Bedienungsanleitung und weitere Informationen rund um das Produkt zu erhalten.

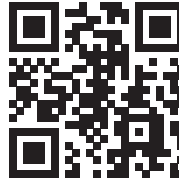

---

**INHALTSVERZEICHNIS**

---

Hinweise zum Zusammenbau 4  
Benötigte Werkzeuge 4  
Kleinteile und Schrauben 5  
Lieferumfang 18  
Zusammenbau 19

English 6  
Español 9  
Français 12  
Italiano 15

---

**HERSTELLER & IMPORTEUR (UK)**

---

**Hersteller:**

Chal-Tec GmbH, Wallstraße 16, 10179 Berlin, Deutschland.

**Importeur für Großbritannien:**

Berlin Brands Group UK Ltd  
PO Box 1145  
Oxford, OX1 9UW  
United Kingdom

## HINWEISE ZUM ZUSAMMENBAU







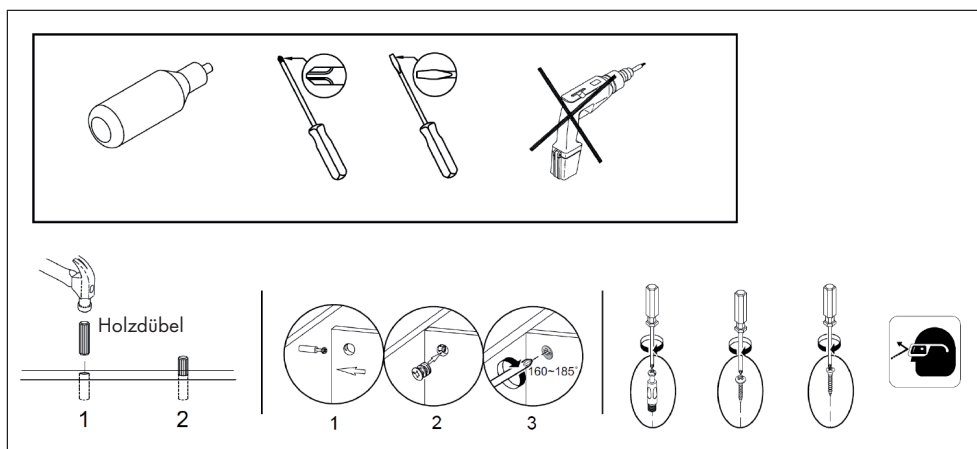

- Stellen Sie das Gehäuse an einem Ort auf, der vor direkter Sonneneinstrahlung geschützt ist.
- Lesen Sie sich alle Hinweise durch, bevor Sie das Gehäuse zusammenbauen.
- Befolgen Sie die Montageanleitung genau.
- Überprüfen Sie vor dem Zusammenbau, ob der Karton alle Teile enthält.
- Um Schäden und Kratzer zu vermeiden, montieren Sie das Gehäuse auf einem weichen Teppich oder einer Decke.
- Reinigen Sie die Gehäuseoberfläche nach dem Aufbau mit einem weichen, trockenen oder leicht feuchten Tuch. Benutzen Sie zur Reinigung keine Scheuermittel.

## BENÖTIGTE WERKZEUGE

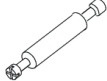
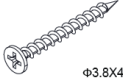
Wir empfehlen Ihnen etwas Holzleim (nicht im Lieferumfang enthalten) in die Löcher zu geben, bevor Sie die Holzdübel einsetzen.

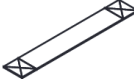

## KLEINTEILE UND SCHRAUBEN

A x 15 	B x 23 	C x 28  Φ7.8X30 mm	D x 4 	E x 8  Φ3.8X45 mm
F x 23  Φ4X35 mm	G x 2  Φ4X12 mm	H x 2 	I x 2 	J x 4 

**Hinweis:** Benutzen Sie immer die richtigen Schrauben, um das Gehäuse nicht zu beschädigen. Identifizieren und sortieren Sie die Schrauben vor dem Zusammenbau. Halten Sie sich genau an die folgende Montageanleitung.

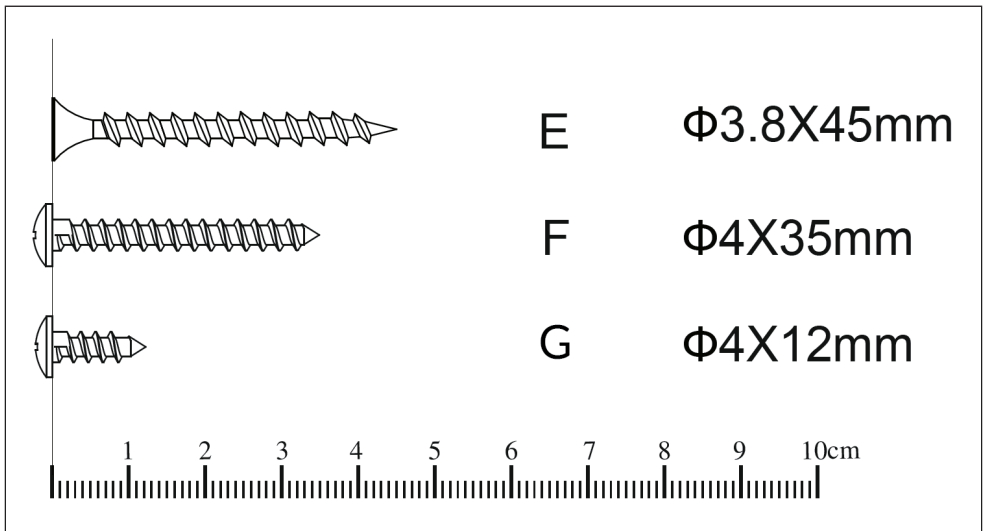

**Dear Customer,**

Congratulations on purchasing this device. Please read the following instructions carefully and follow them to prevent possible damages. We assume no liability for damage caused by disregard of the instructions and improper use. Scan the QR code to get access to the latest user manual and more product information.



---

**CONTENT**

---

Hints on Assembly 7  
Necessary Tools 7  
Small Parts and Screws 8  
Scope of delivery 18  
Assembly 19

---

**MANUFACTURER & IMPORTER (UK)**

---

**Manufacturer:**

Chal-Tec GmbH, Wallstrasse 16, 10179 Berlin, Germany.

**Importer for Great Britain:**

Berlin Brands Group UK Ltd  
PO Box 1145  
Oxford, OX1 9UW  
United Kingdom

## HINTS ON ASSEMBLY







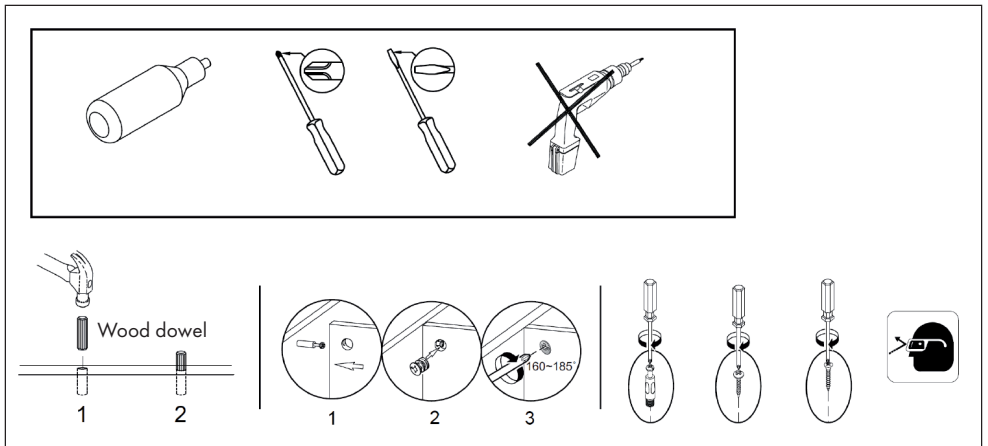



- Find a location for the fireplace heater that is protected from direct sunlight.
- Do not plug the electric fireplace heater into the power outlet before you read all instruction.
- Follow carefully the assembly instructions.
- Check to ensure this carton contains all parts.
- To prevent product damage, assemble the furniture on the carton.
- Clean surface of furniture with a duster or damp cloth only, do not use abrasive cleaners.

## NECESSARY TOOLS

We recommend to apply some wood glue (not included in the packing content) into holes before inserting wood dowels.



## SMALL PARTS AND SCREWS

<p>A x 15</p> 	<p>B x 23</p> 	<p>C x 28</p>  <p>Φ7.8X30 mm</p>	<p>D x 4</p> 	<p>E x 8</p>  <p>Φ3.8X45 mm</p>
<p>F x 23</p>  <p>Φ4X35 mm</p>	<p>G x 2</p>  <p>Φ4X12 mm</p>	<p>H x 2</p> 	<p>I x 2</p> 	<p>J x 4</p> 

**Note:** Always use the correct screws to avoid damaging the housing. Identify and sort the screws before assembly. Follow the following assembly instructions carefully.

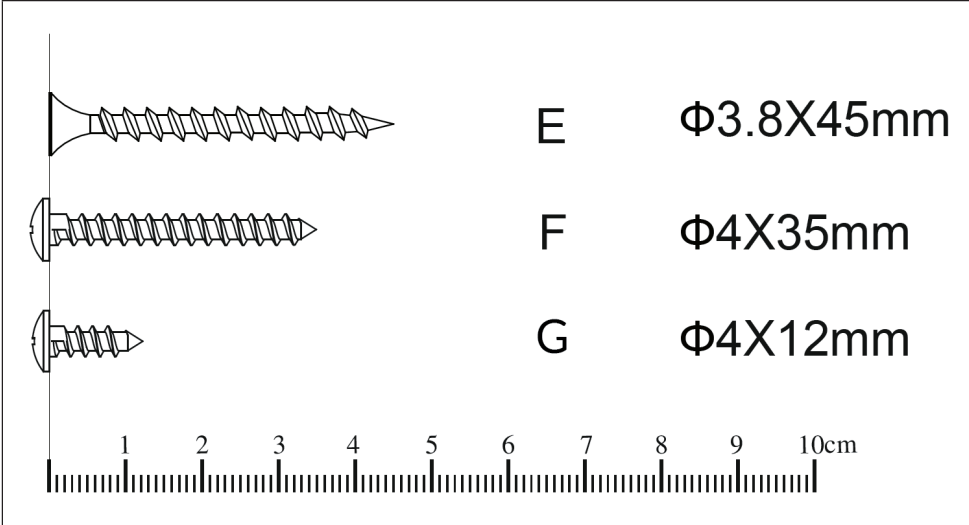

E      Φ3.8X45mm

F      Φ4X35mm

G      Φ4X12mm

1 2 3 4 5 6 7 8 9 10cm



**Estimado cliente,**

Le felicitamos por la adquisición de este producto. Lea atentamente las siguientes instrucciones y sígalas para evitar posibles daños. No asumimos ninguna responsabilidad por los daños causados por el incumplimiento de las instrucciones y el uso inadecuado. Escanee el siguiente código QR para obtener acceso a la última guía del usuario y más información sobre el producto.

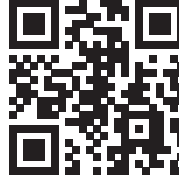

---

**ÍNDICE**

---

Indicaciones sobre el montaje 10  
Herramientas necesarios 10  
Piezas y tornillos incluidos 11  
Volumen de suministro 18  
Ensamblaje 19

---

**FABRICANTE E IMPORTADOR (REINO UNIDO)**

---

**Fabricante:**

Chal-Tec GmbH, Wallstraße 16, 10179 Berlín, Alemania.

**Importador para Gran Bretaña:**

Berlin Brands Group UK Ltd  
PO Box 1145  
Oxford, OX1 9UW  
United Kingdom

## INDICACIONES SOBRE EL MONTAJE







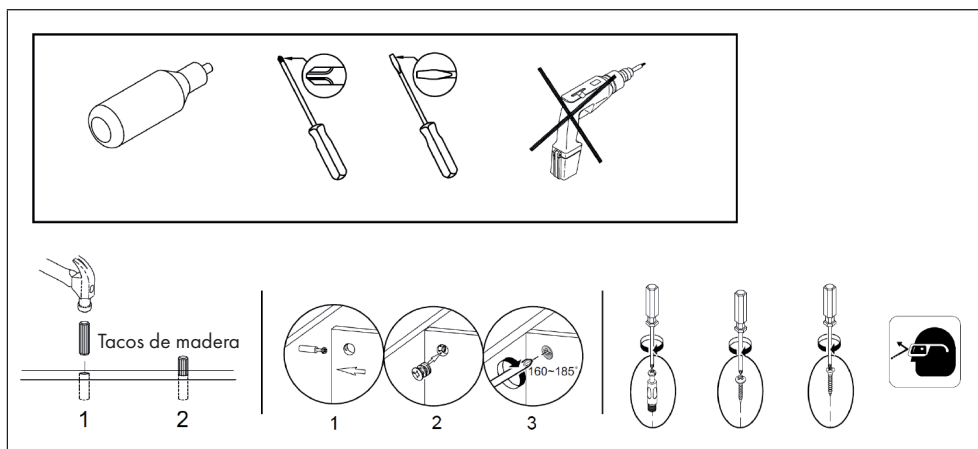

- Coloque el marco en un lugar protegido de la luz directa del sol.
- Lea atentamente todas las indicaciones antes de montar el aparato.
- Siga las instrucciones de montaje.
- Antes del montaje, compruebe que la caja contenga todas las piezas.
- Para evitar daños y arañazos, monte el aparato sobre una alfombra o manta.
- Limpie la superficie del aparato tras el montaje con un paño suave y seco o ligeramente húmedo. No utilice productos abrasivos ni disolventes.

## HERRAMIENTAS NECESARIOS

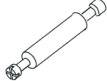
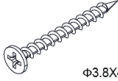
Le recomendamos emplear un poco de cola de carpintero (no incluida en el envío) en los orificios antes de encajar los tacos de madera.



## PIEZAS Y TORNILLOS INCLUIDOS

A x 15 	B x 23 	C x 28  $\Phi 7.8 \times 30$ mm	D x 4 	E x 8  $\Phi 3.8 \times 45$ mm
F x 23  $\Phi 4 \times 35$ mm	G x 2  $\Phi 4 \times 12$ mm	H x 2 	I x 2 	J x 4 

**Advertencia:** utilice siempre los tornillos adecuados para no dañar el marco. Identifique y clasifique los tornillos antes del montaje. Cíñase a las instrucciones de este manual.

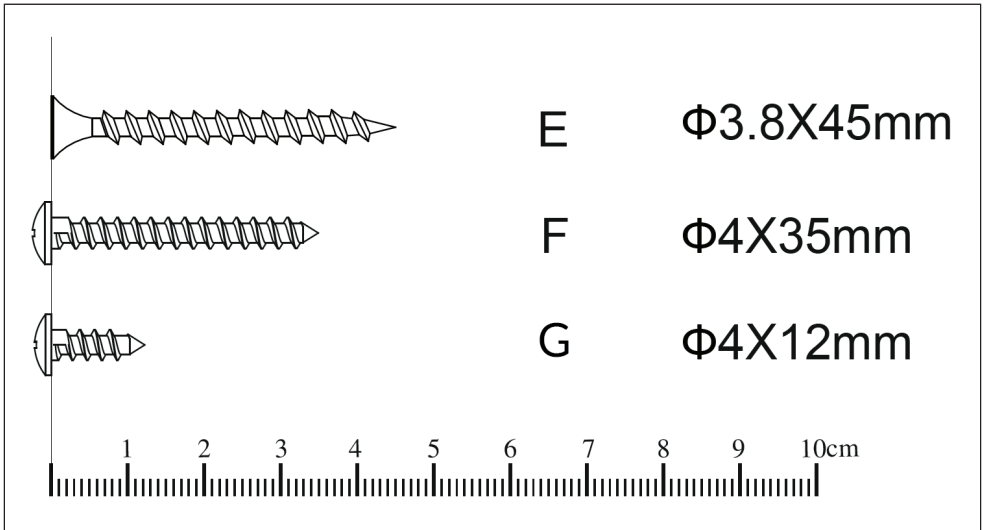

**Chère cliente, cher client,**

Toutes nos félicitations pour l'acquisition de ce nouvel appareil. Veuillez lire attentivement et respecter les instructions de ce mode d'emploi afin d'éviter d'éventuels dommages. Nous ne saurions être tenus pour responsables des dommages dus au non-respect des consignes et à la mauvaise utilisation de l'appareil. Scannez le QR-Code pour obtenir la dernière version du mode d'emploi et des informations supplémentaires concernant le produit.

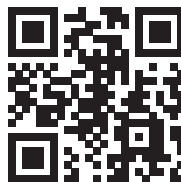

---

## **SOMMAIRE**

---

Conseils pour l'assemblage 13  
Outillage nécessaire et aides 13  
Petits éléments fournis et vis 14  
Contenu de la livraison 18  
Assemblée 19

---

## **FABRICANT ET IMPORTATEUR (UK)**

---

**Fabricant :**

Chal-Tec GmbH, Wallstraße 16, 10179 Berlin, Allemagne.

**Importateur pour la Grande Bretagne :**

Berlin Brands Group UK Ltd  
PO Box 1145  
Oxford, OX1 9UW  
United Kingdom

## CONSEILS POUR L'ASSEMBLAGE







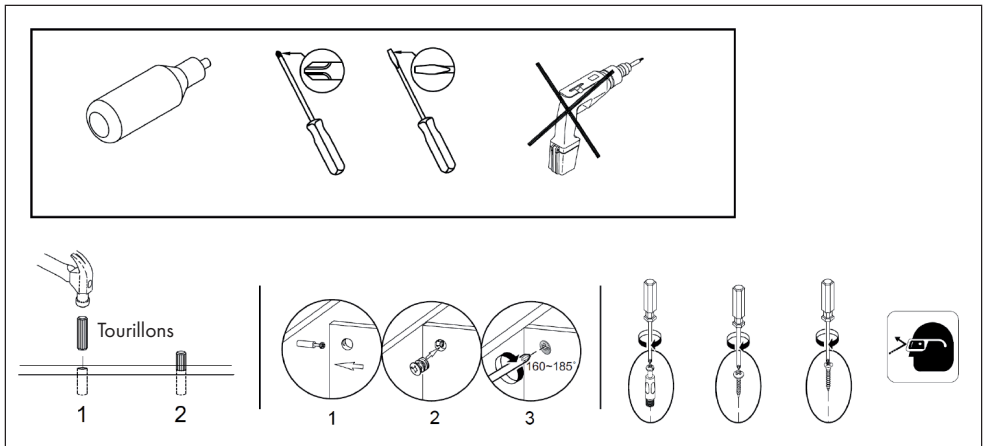

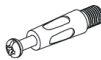

- Placez l'insert dans un endroit à l'abri de l'ensoleillement direct.
- Lisez bien toutes les consignes avant d'assembler l'insert.
- Suivez précisément les indications de montage.
- Avant l'assemblage, vérifiez que le carton contient bien toutes les pièces.
- Pour éviter les dommages et les rayures, assemblez l'insert sur un tapis doux ou une couverture.
- Nettoyez les surfaces de l'insert à la fin de l'assemblage avec un chiffon doux, sec ou légèrement humide. N'utilisez aucun produit abrasif.

## OUTILLAGE NÉCESSAIRE ET AIDES

Nous vous conseillons de mettre un peu de colle à bois (non fournie) dans les trous avant d'insérer les tourillons.



## PETITS ÉLÉMENTS FOURNIS ET VIS

A x 15 	B x 23 	C x 28  Φ7.8X30 mm	D x 4 	E x 8  Φ3.8X45 mm
F x 23  Φ4X35 mm	G x 2  Φ4X12 mm	H x 2 	I x 2 	J x 4 

Remarque : utilisez toujours les bonnes vis pour ne pas endommager l'insert. Repérez et triez les vis avant de commencer l'assemblage. Tenez-vous en strictement aux indications de montage.

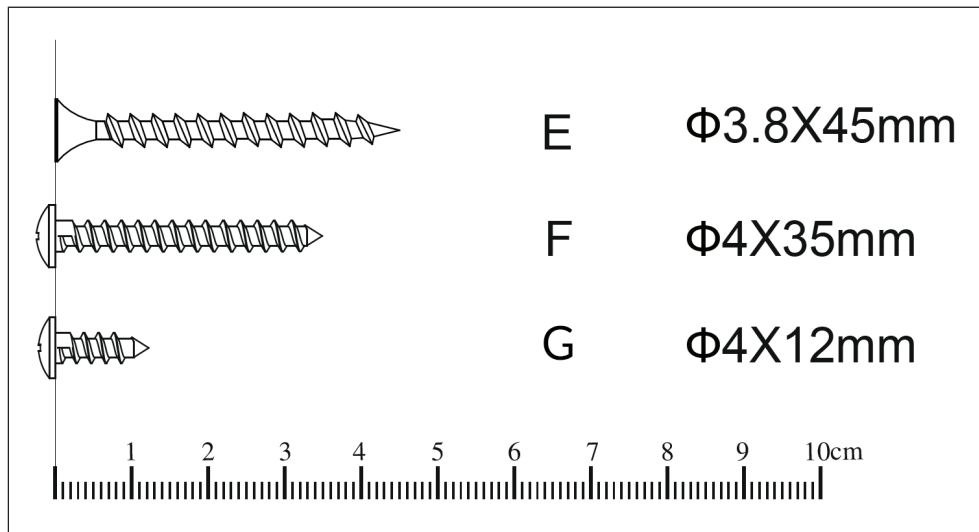

**Gentile cliente,**

La ringraziamo per aver acquistato il dispositivo. La preghiamo di leggere attentamente le seguenti istruzioni per l'uso e di seguirle per evitare possibili danni. Non ci assumiamo alcuna responsabilità per danni scaturiti da una mancata osservazione delle avvertenze di sicurezza e da un uso improprio del dispositivo. Scansionare il codice QR seguente, per accedere al manuale d'uso più attuale e per ricevere informazioni sul prodotto.



---

## **INDICE**

---

Note per il montaggio 16

Attrezzi necessari 16

Componenti e viti inclusi nella consegna 17

Dotazione di fornitura 18

Assemblaggio 19

---

## **PRODUTTORE E IMPORTATORE (UK)**

---

**Produttore:**

Chal-Tec GmbH, Wallstraße 16, 10179 Berlino, Germania.

**Importatore per la Gran Bretagna:**

Berlin Brands Group UK Ltd

PO Box 1145

Oxford, OX1 9UW

United Kingdom

## NOTE PER IL MONTAGGIO

- Installare la cornice per il caminetto in un luogo non esposto alla luce diretta del sole.
- Leggere tutte le istruzioni prima di assemblare la cornice per il caminetto.
- Seguire attentamente tutte le istruzioni.
- Prima del montaggio verificare che tutti i componenti siano contenuti nella confezione.
- Per evitare di danneggiare o di graffiare la cornice, montarla su una superficie morbida.
- Dopo il montaggio, pulire le superfici della cornice con un panno morbido, asciutto o leggermente umido. Non utilizzare per la pulizia prodotti abrasivi.





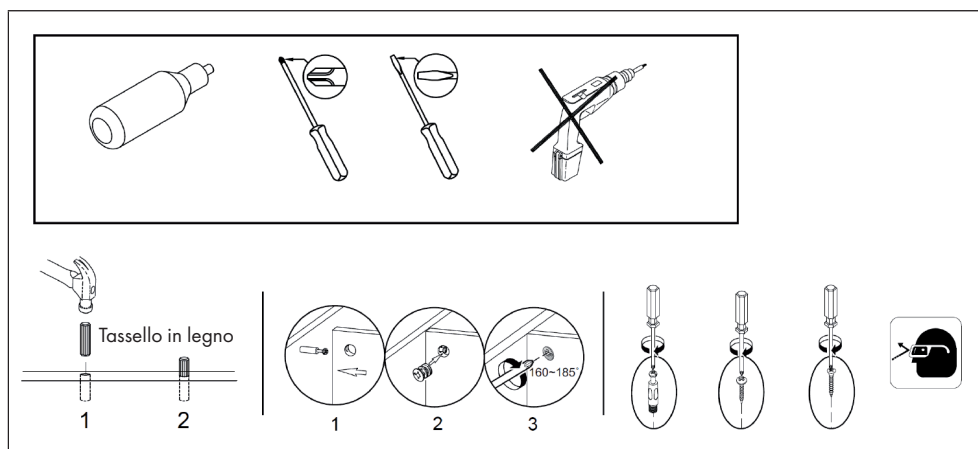



## ATTREZZI NECESSARI

Prima di inserire i tasselli in legno, si consiglia di applicare nei fori un po' di colla per legno (non inclusa nella consegna).

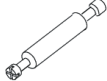
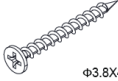

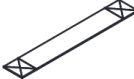

## COMPONENTI E VITI INCLUSI NELLA CONSEGNA

A x 15 	B x 23 	C x 28  Φ7.8X30 mm	D x 4 	E x 8  Φ3.8X45 mm
F x 23  Φ4X35 mm	G x 2  Φ4X12 mm	H x 2 	I x 2 	J x 4 

**Nota:** utilizzare sempre le viti corrette per non danneggiare la cornice. Identificare e classificare le viti prima del montaggio. Attenersi alle istruzioni per il montaggio che seguono.

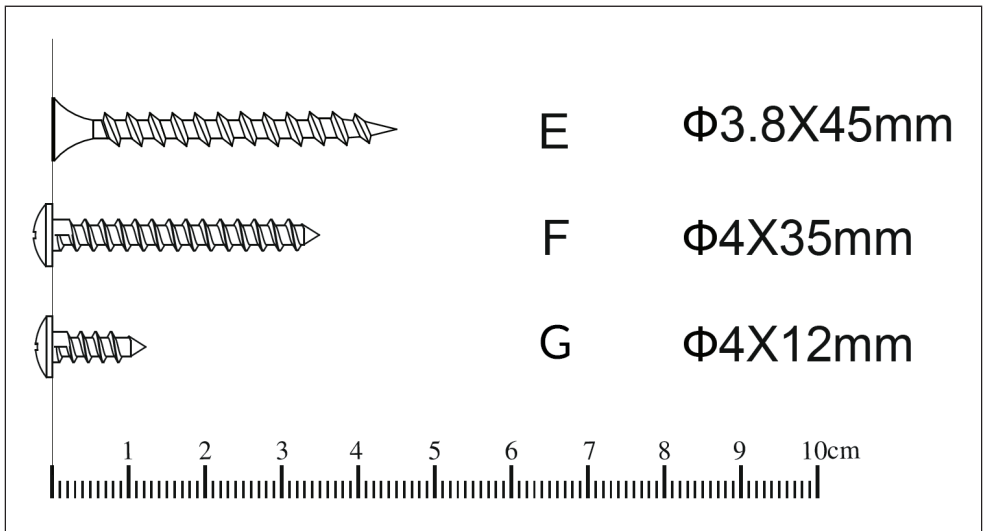

## LIEFERUMFANG

Scope of delivery | Volumen de suministro | Contenu de la livraison |  
Dotazione di fornitura

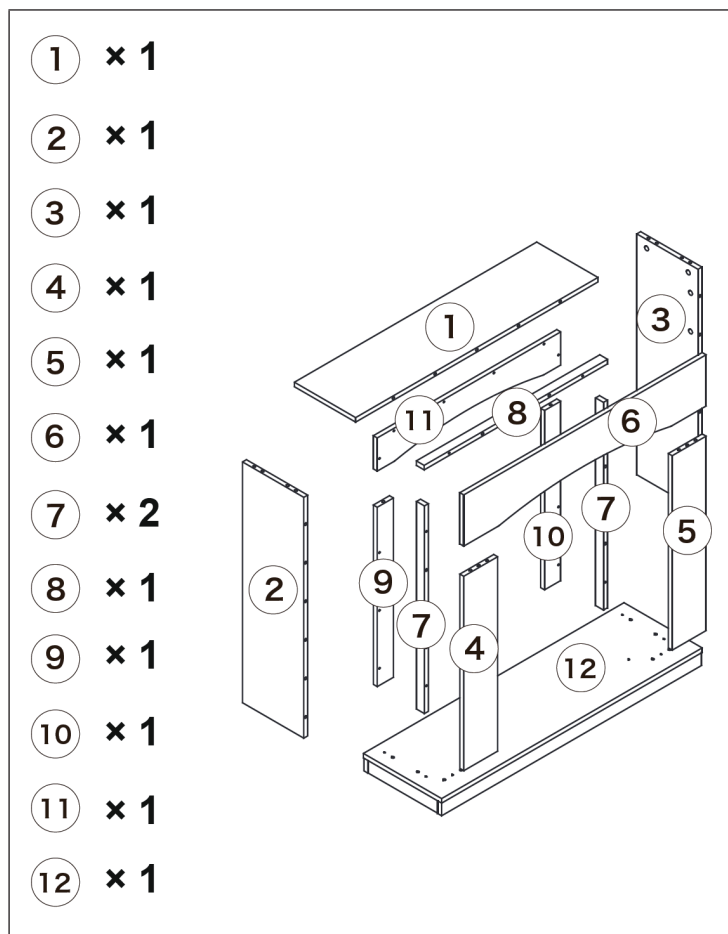

# ZUSAMMENBAU

Assembly | Ensamblaje | Assemblée | Assemblaggio

**1**

C x 2pcs

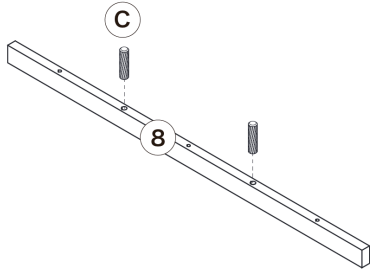

**2**

C x 4pcs

x2

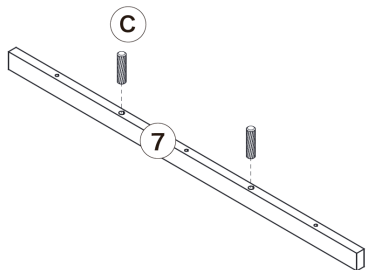

3

A x 3pcs

C x 4pcs

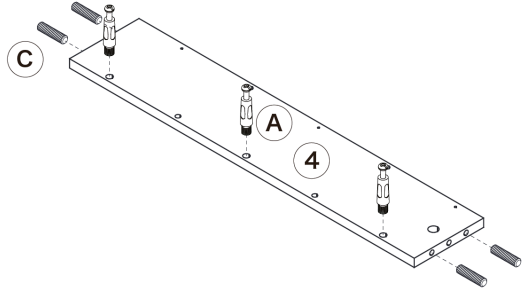

4

A x 3pcs

C x 4pcs

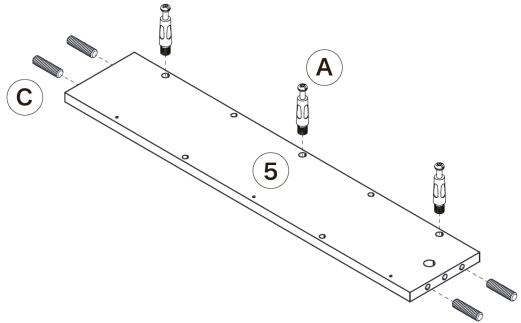

5



A x 5pcs

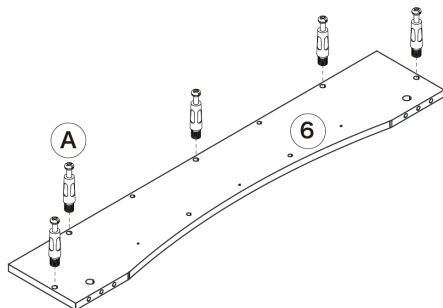

6



B x 4pcs



D x 2pcs

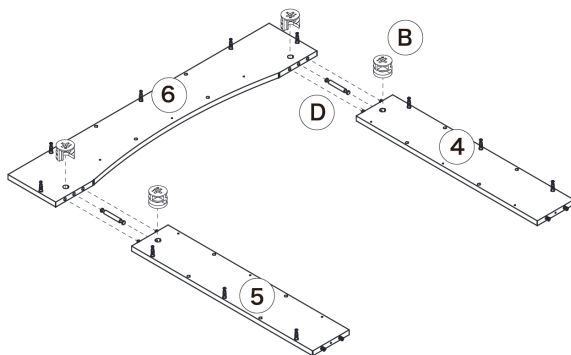

7

A x 4pcs  
C x 2pcs

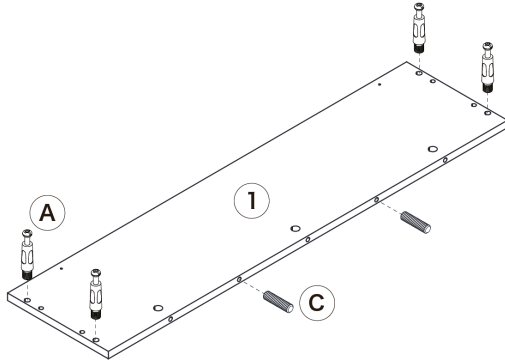

8

C x 6pcs

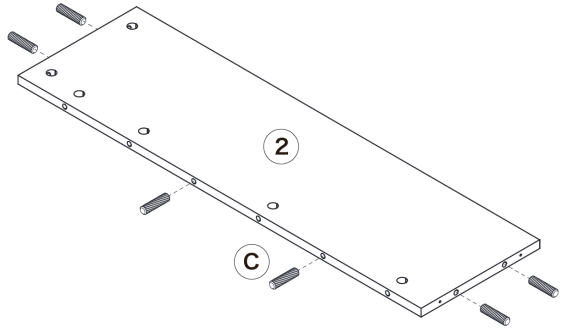

9

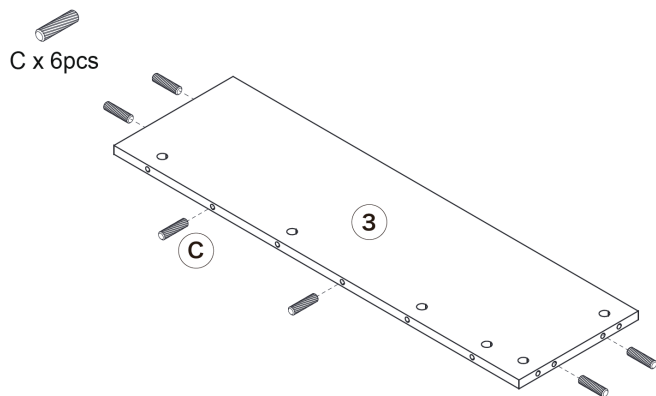

10

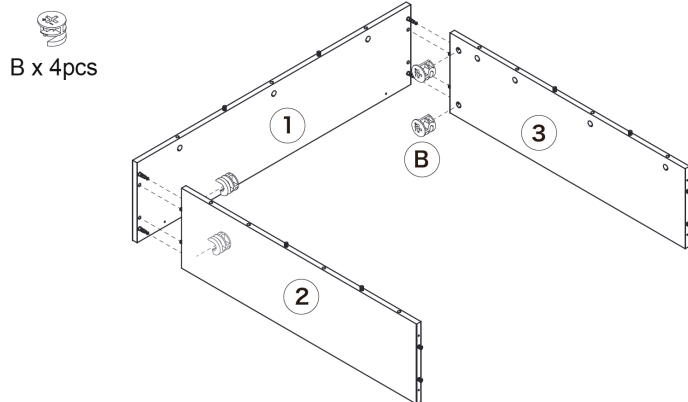

# 11



B x 11pcs

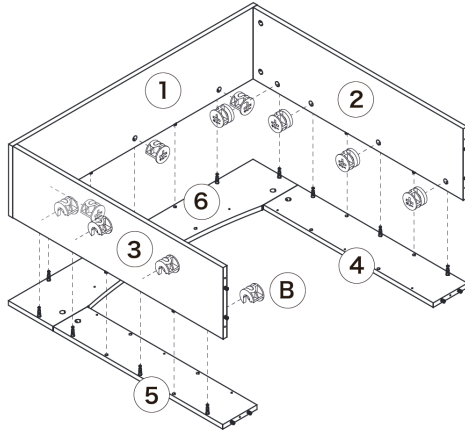

# 12



F x 9pcs

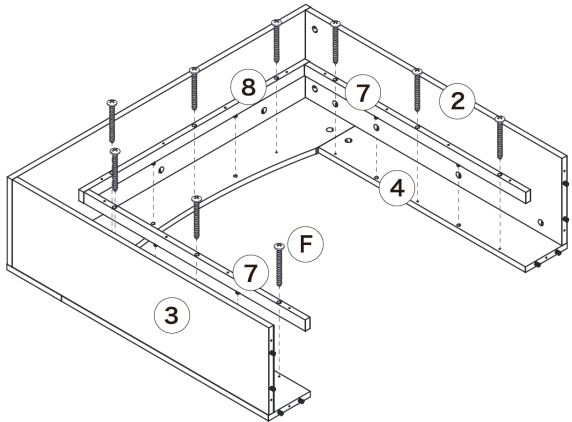



# 13

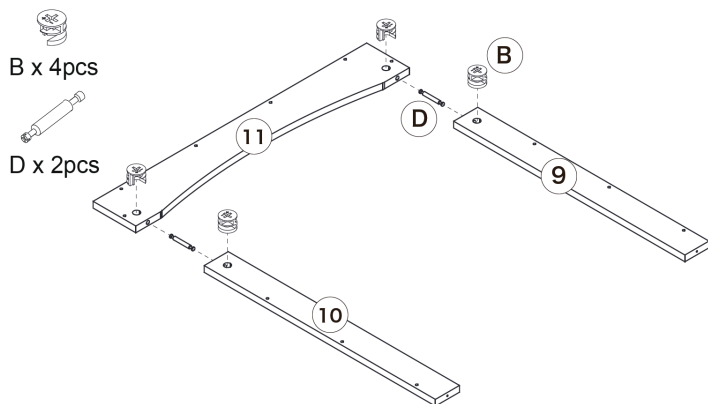

# 14

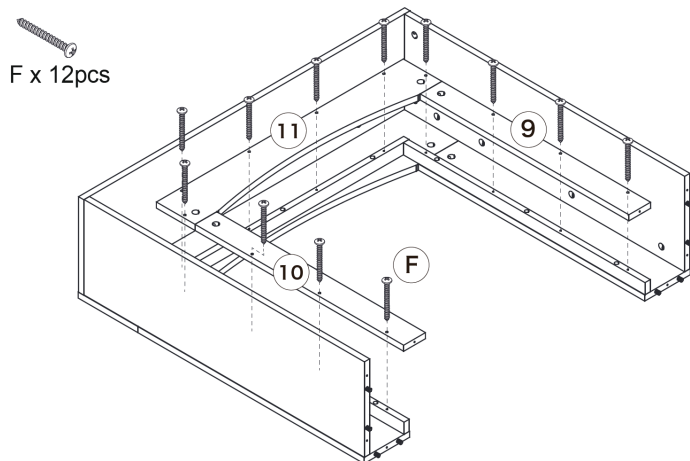

# 15

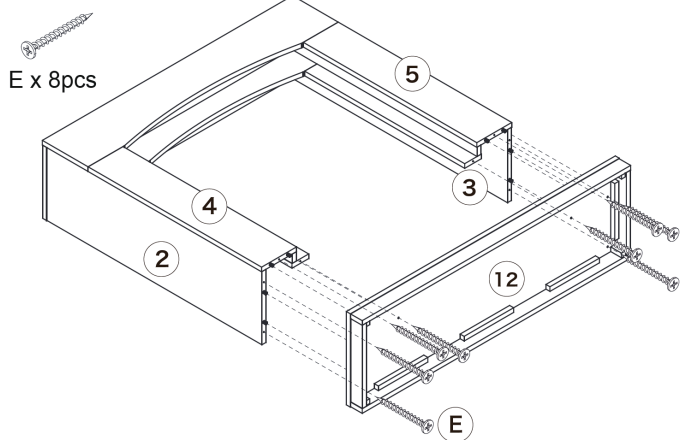

# 16

G x 2pcs

I x 2pcs

J x 2pcs

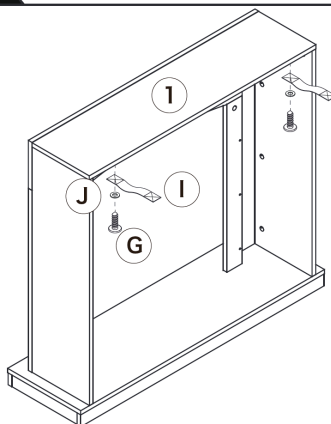



F x 2pcs



H x 2pcs



J x 2pcs

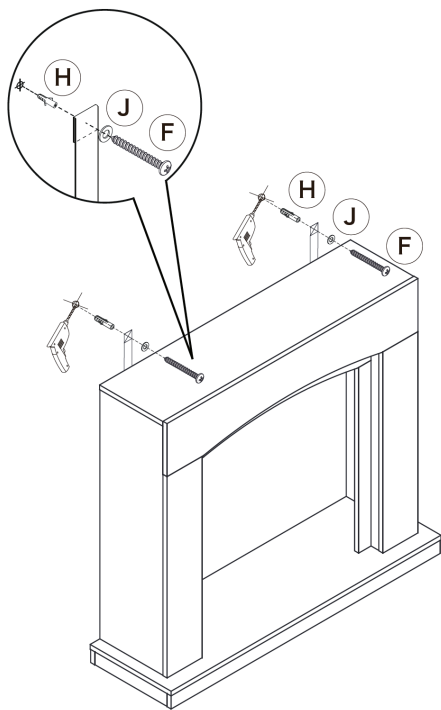



**KLARSTEIN**