

10034212

10035491

Arrowhead

Tischfußball mit Beleuchtung

Illuminated Football Table

Babyfoot avec éclairage

Biliardino con illuminazione

Futbolín con iluminación

Sehr geehrter Kunde,

wir gratulieren Ihnen zum Erwerb Ihres Gerätes. Lesen Sie die folgenden Hinweise sorgfältig durch und befolgen Sie diese, um möglichen Schäden vorzubeugen. Für Schäden, die durch Missachtung der Hinweise und unsachgemäßen Gebrauch entstehen, übernehmen wir keine Haftung. Scannen Sie den folgenden QR-Code, um Zugriff auf die aktuellste Bedienungsanleitung und weitere Informationen rund um das Produkt zu erhalten.



INHALTSVERZEICHNIS

Artikel 3
Sicherheitshinweise 4
Lieferumfang 5
Montage 7
Funktion von LED-Leuchten und elektronischem Zähler 14
Schaltplan 15
Reinigung und Pflege 16
Hinweise zur Entsorgung 17
Konformitätserklärung 17









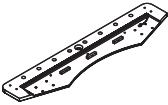
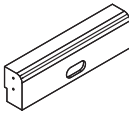
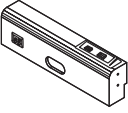
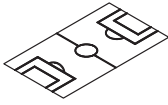
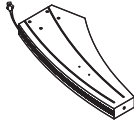
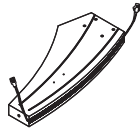

ARTIKEL

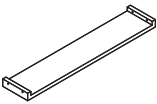
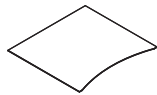
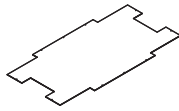
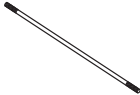





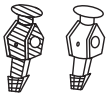

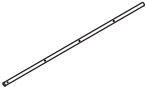
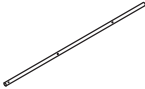
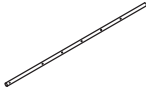
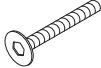

Artikelnummer	10034212, 10035491
---------------	--------------------

SICHERHEITSHINWEISE

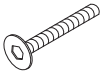
- Die Montage darf nur durch einen Erwachsenen erfolgen. Das zusammengebaute Tischfußballspiel ist in seinen Abmessungen relativ groß und könnte nicht gut durch Türen passen. Daher wird empfohlen, das Tischfußballspiel in dem Raum zusammenzubauen, in dem gespielt werden soll.
- Falls Sie den Spieltisch in einen anderen Raum transportieren möchten, müssen möglicherweise die Beine erst abmontiert und dann wieder angebracht werden.
- Dieser Kickertisch ist nur für die private Nutzung geeignet.
- Verwenden Sie dieses Gerät ausschließlich für den beabsichtigten Zweck.
- Beachten Sie bitte die folgenden Sicherheitshinweise, um eine lange Lebensdauer und optimale Funktionstüchtigkeit Ihres Tischfußballspiels zu gewährleisten:
- Den Kickertisch nicht im Freien stehen lassen. Regen, Schnee und hohe Luftfeuchtigkeit schaden dem Material. Auch eine längere Sonneneinstrahlung ist aufgrund der ausbleichenden Wirkung auf die Farben nicht zu empfehlen.
- Wenn Sie den Kickertisch an eine andere Person weitergeben stellen Sie sicher, dass diese Person den Inhalt der Aufbau- und Bedienungsanleitung kennt.
- Stellen Sie diesen Tischkicker immer auf einen ebenen und festen Untergrund.
- Vor jeder Nutzung sollten Sie alle Teile auf Ihre Funktion überprüfen und bei nicht einwandfreier Nutzbarkeit diesen Tisch nicht benutzen.
- Verwenden Sie immer eine Unterlage (Pappe oder Teppich) unter den Tischbeinen des Gerätes zum Schutz Ihrer Einrichtung.
- **ACHTUNG:** Um Probleme bei der Montage bzw. Befestigung der Tischbeine zu vermeiden, schrauben Sie zunächst alle Tischbeine gleich an und abschließend alle fest.
- Dieses Gerät ist nicht für die Verwendung durch Personen vorgesehen (Kinder eingeschlossen), die verminderte körperliche, sensorische oder geistige Fähigkeiten haben oder nicht über ausreichende Erfahrung und Kenntnisse verfügen; es sei denn sie haben von einer Person, die für ihre Sicherheit verantwortlich ist, Anleitung für den Gebrauch des Gerätes.
- Betreiben Sie das Gerät nicht mit einem beschädigten Stecker. Auch nicht, wenn das Gerät nicht funktioniert, irgendwie beschädigt wurde, in Wasser oder eine andere Flüssigkeit getaucht wurde. Senden Sie in diesem Fall das Gerät an die angegebene Adresse zur Reparatur oder Überprüfung.

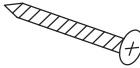
LIEFERUMFANG

<p>#1</p>  <p>Seitenteil 2 x</p>	<p>#2</p>  <p>Stirnseitenteil mit Tor 1x</p>	<p>#3</p>  <p>Stirnseitenteil mit Tor 1x</p>	<p>#4</p>  <p>Spielfeld 1x</p>
<p>#5</p>  <p>linkes Bein 2 x</p>	<p>#6</p>  <p>rechtes Bein 2 x</p>	<p>#7</p>  <p>Stützbügel 3 x</p>	<p>#8</p>  <p>Beinplatte A 2 x</p>
<p>#9</p>  <p>Beinplatte B 4 x</p>	<p>#10</p>  <p>Unterbrett 1x</p>	<p>#11</p>  <p>Stützstange 1/4"×720mm 3 x</p>	<p>#12</p>  <p>Innensechskant- 1/4" Hülse 6 x</p>
<p>#13</p>  <p>Fußschraube 4 x</p>	<p>#14</p>  <p>Sechskantschlüssel 2 x</p>	<p>#15</p>  <p>Ballaufnahme 2 x</p>	<p>#16</p>  <p>Gummipuffer Spielstange 16 x</p>
<p>#17</p>  <p>Kunststoff- Unterlegscheibe 16 x</p>	<p>#18</p>  <p>Spielfiguren 11+11 x</p>	<p>#19</p>  <p>Spielstangen-Griff 8 x</p>	<p>#20</p>  <p>Endkappe 8 x</p>

<p>#21</p>  <p>M4X28mm Schraube 26 x</p>	<p>#22</p>  <p>M4 Mutter 26 x</p>	<p>#23</p>  <p>Netzgerät 1 x</p>	<p>#24</p>  <p>3-Spieler-Stange 4 x</p>
<p>#25</p>  <p>2-Spieler-Stange 2 x</p>	<p>#26</p>  <p>5-Spieler-Stange 2 x</p>	<p>#27</p>  <p>1/4" * 1-1/2" Schraube 8 x</p>	<p>#28</p>  <p>Unterlegscheibe 8 x</p>
<p>#29</p>  <p>5/16" Schraube 16 x</p>	<p>#30</p>  <p>5/16" Unterlegscheibe 16 x</p>	<p>#31</p>  <p>Schraube T3.5X45mm 8 x</p>	<p>#32</p>  <p>Schraube T3.5X25mm 16 x</p>
<p>#33</p>  <p>Schraube T3.5X12mm 16 x</p>	<p>#34</p>  <p>Torstopper 4 x</p>	<p>#35</p>  <p>Ball 2 x</p>	

MONTAGE

Schritt 1

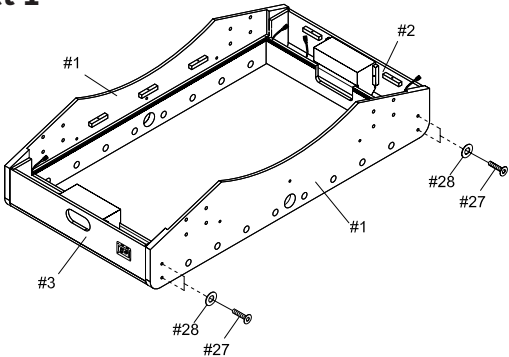

Schritt 2

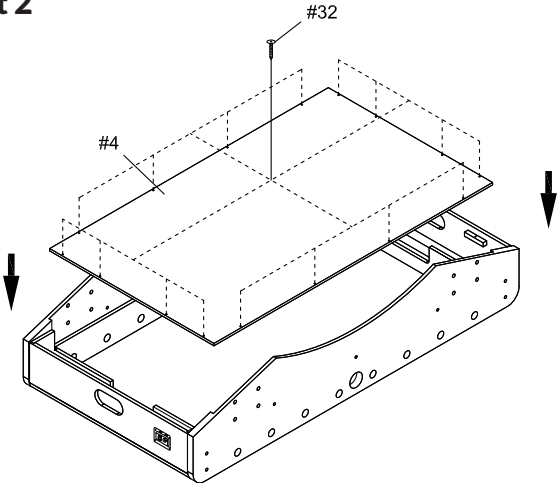

Schritt 3

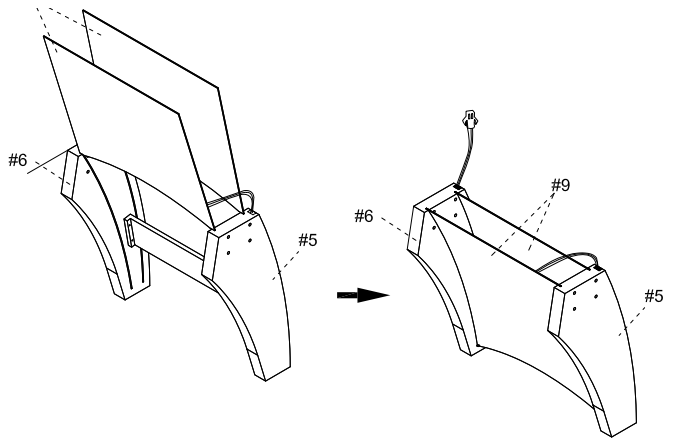

Schritt 4

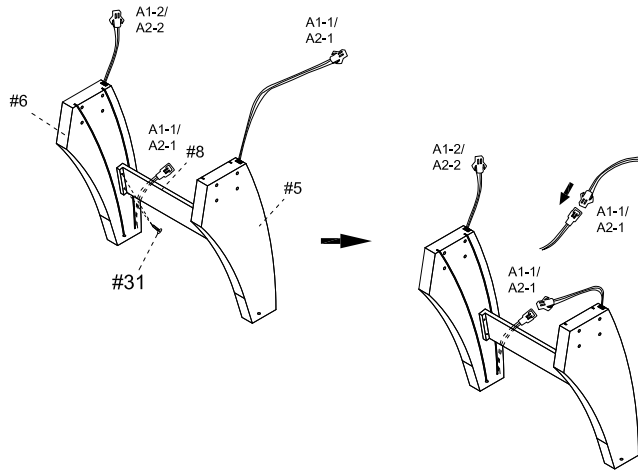

Schritt 5

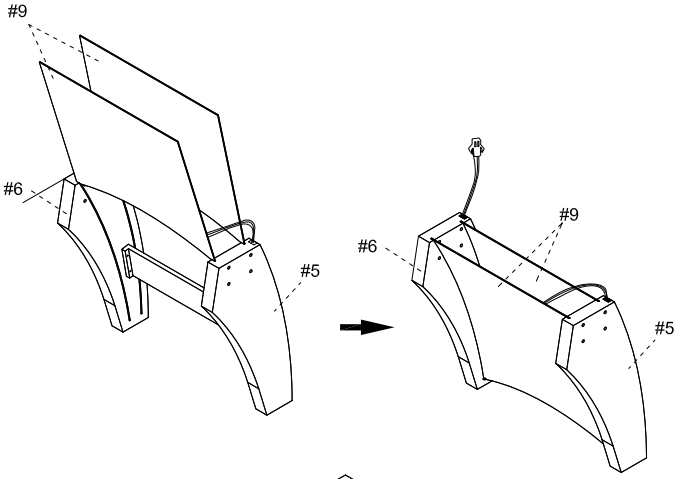

Schritt 6

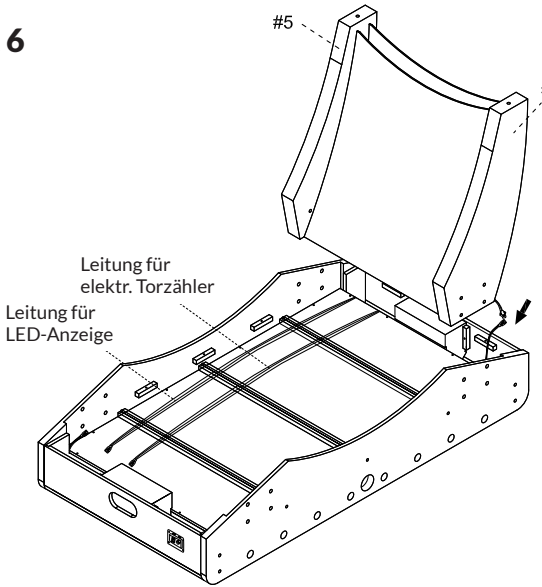

Schritt 7

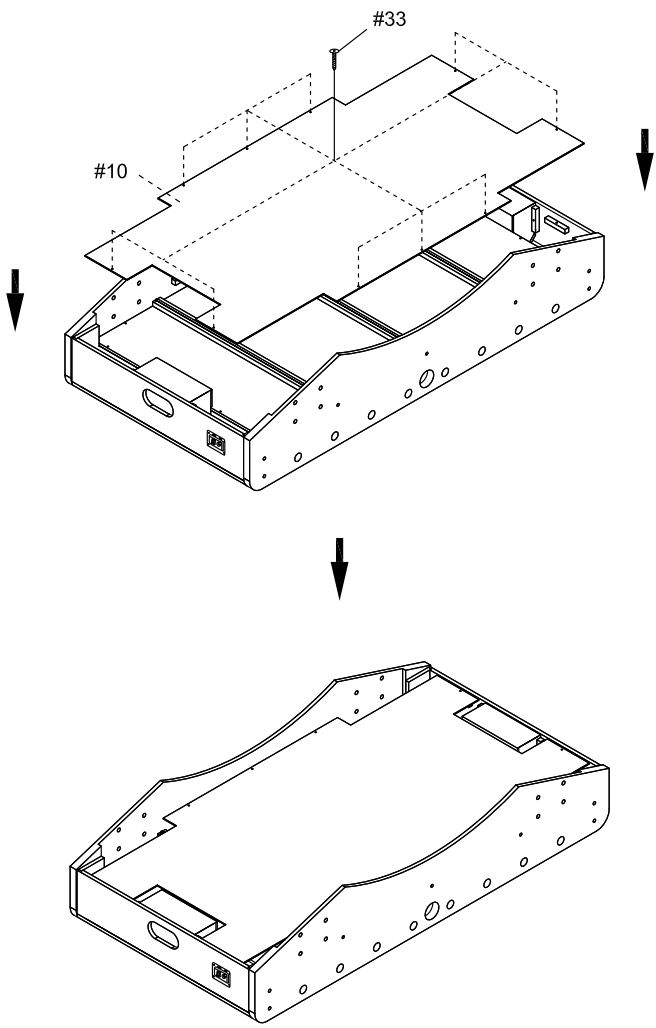

Schritt 8

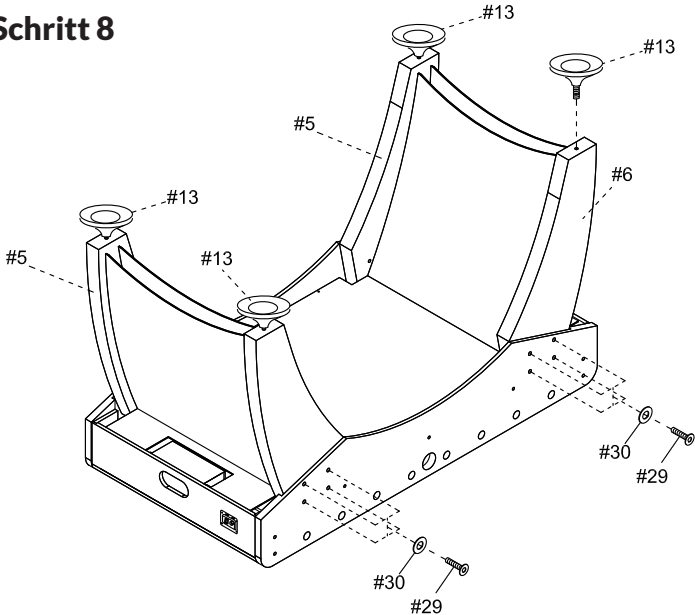

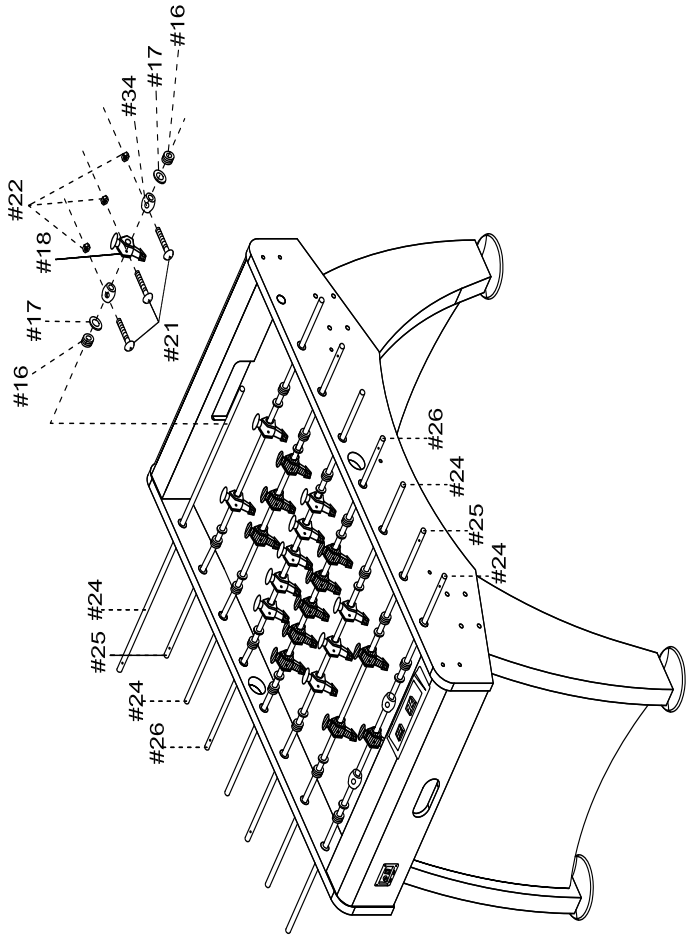

Schritt 9

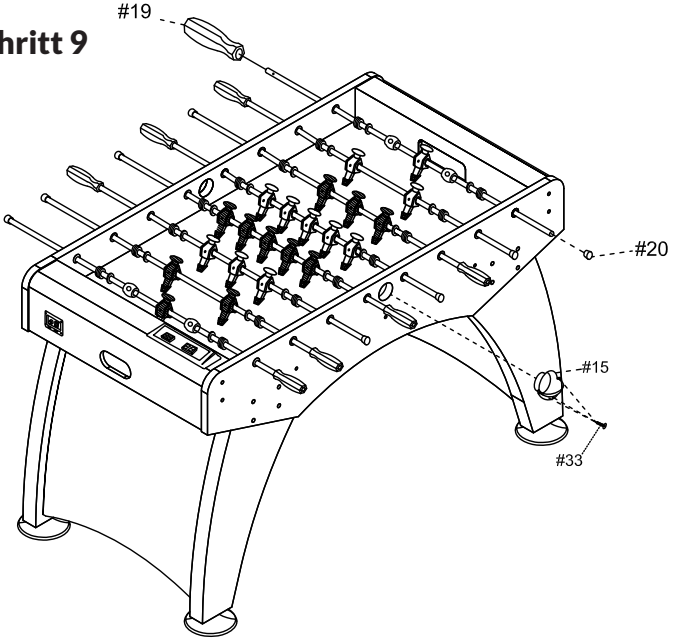

Schritt 10

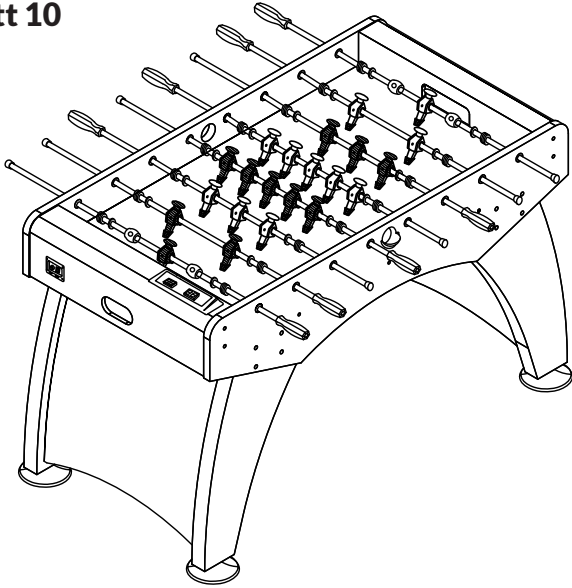

FUNKTION VON LED-LEUCHTEN UND ELEKTRONISCHEM ZÄHLER

Nehmen Sie den Netzstecker des Geräts und verbinden Sie ihn mit der Steckdose in Ihrem Zimmer. Alle LED-Leuchten leuchten auf und der elektronische Zähler ist betriebsbereit.

Drücken Sie die EIN-Taste des elektronischen Zählers. Die Displays der Leiste leuchten auf und sind betriebsbereit. Der Counter ist in der Lage, für zwei Spieler oder Teams von 0 bis 99 Toren zu zählen. Jedes Mal, wenn einer der Spieler oder das Team ein Tor schießt, fügt der Zähler das Tor zur Zählung hinzu, gibt ein akustisches Signal und gibt auch eine LED-Lichtshow ab. Sie können das Spiel jederzeit starten.

Drücken Sie die RESET-Taste, wenn Sie das laufende Spiel stoppen und ein neues Spiel starten möchten. Beide Zähler werden auf Null zurückgesetzt. Du kannst dies jederzeit tun.

Drücken Sie die AUS-Taste des elektronischen Zählers, um das Spiel zu stoppen. Die Anzeige des Zählers erlischt. Ziehen Sie den Netzstecker aus der Steckdose und bewahren Sie den Kickertisch sicher auf.

SCHALTPLAN

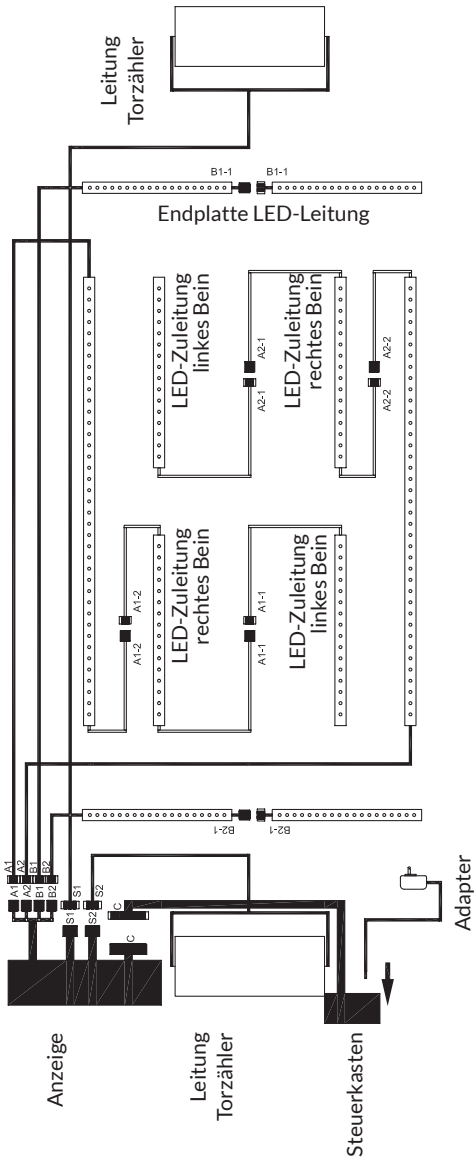

REINIGUNG UND PFLEGE

Damit ein neuer Tischkicker seine perfekten Spieleigenschaften beibehält, muss er natürlich ordentlich gepflegt werden. Dabei beschränkt sich die Pflege des Kickers hauptsächlich auf das Schmieren der Kickerstangen und die Reinigung des Spielfelds.

Reinigung der Spielerstangen

Zum Reinigen der Stangen geben Sie ein bisschen Fensterreiniger auf ein weiches Tuch und putzen damit die Stangen ab. Zudem schmieren Sie die Stangen noch, damit sie einen optimalen Lauf haben.

Schmieren der Spielerstangen

Reines Silikonöl eignet sich gut als Schmiermittel. Geben Sie nicht mehr als ein bis zwei Tropfen auf die jeweilige Stange. Diese Tropfen verteilen Sie dann auf der Stange und in die Lager. Wenn Sie zu viel Silikonöl auftragen, kann es tropfen und das Spielfeld sowie der Kickerball werden schmierig.

Reinigung des Spielfelds

Greifen Sie nicht zu aggressiven Reinigungsmitteln oder Reinigern, die sich nicht restlos entfernen lassen. Daher empfiehlt sich die Reinigung des Tisches nur mit Wasser.

Sollten Sie ölige Rückstände auf dem Spielfeld haben, verwenden Sie vorzugsweise einen Fensterreiniger ohne besondere Zusätze.

HINWEISE ZUR ENTSORGUNG

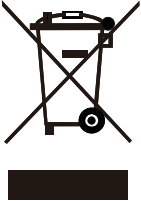

Befindet sich die linke Abbildung (durchgestrichene Mülltonne auf Rädern) auf dem Produkt, gilt die Europäische Richtlinie 2012/19/EU. Diese Produkte dürfen nicht mit dem normalen Hausmüll entsorgt werden. Informieren Sie sich über die örtlichen Regelungen zur getrennten Sammlung elektrischer und elektronischer Gerätschaften. Richten Sie sich nach den örtlichen Regelungen und entsorgen Sie Altgeräte nicht über den Hausmüll. Durch die regelkonforme Entsorgung der Altgeräte werden Umwelt und die Gesundheit Ihrer Mitmenschen vor möglichen negativen Konsequenzen geschützt. Materialrecycling hilft, den Verbrauch von Rohstoffen zu verringern.

KONFORMITÄTSERKLÄRUNG

Hersteller:

Chal-Tec GmbH, Wallstraße 16, 10179 Berlin,
Deutschland.



**Dieses Produkt entspricht den folgenden
Europäischen Richtlinien:**

2011/65/EU (RoHS)
2014/30/EU (EMV)
2014/35/EU (LVD)

Dear Customer,

Congratulations on purchasing this equipment. Please read this manual carefully and take care of the following hints to avoid damages. Any failure caused by ignoring the items and cautions mentioned in the instruction manual are not covered by our warranty and any liability. Scan the QR code to get access to the latest user manual and other information about the product.

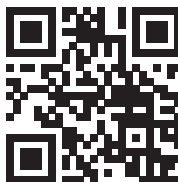

CONTENTS

- Item 19
- Safety Instructions 20
- Scope of Supply 21
- Assembly 23
- Wiring 30
- Function of LED Lights and electronic counter 31
- Cleaning and Care 32
- Disposal Considerations 33
- Declaration of Conformity 33









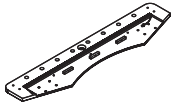
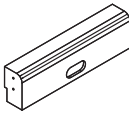
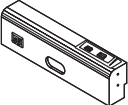
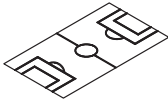
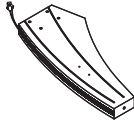
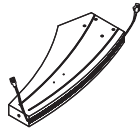

ITEM

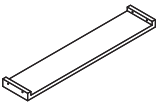
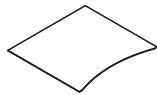
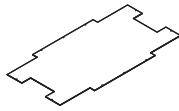
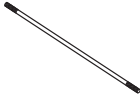





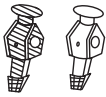

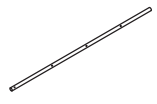
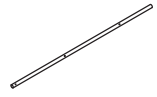
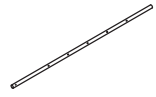
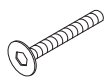

Item number	10034212, 10035491
-------------	--------------------

SAFETY INSTRUCTIONS

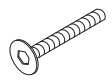
- **ASSEMBLY AND DISMANTLING MUST ONLY BE CARRIED OUT BY ADULTS.** Once assembled your table is quite wide and may not fit through your doors. For this reason you should assemble it in the room you intend it to be used. Should you wish to move your table to another room, it might be necessary to remove its legs.
- This table football set is only designed for private use. For commercial use, the warranty loses its validity. Please use this game exclusively for its intended purpose.
- Your table has been manufactured for indoor playing: do not leave it outdoors. Rain, snow and high humidity may damage its materials. Prolonged exposure to the sun is to be avoided too, due to its ultraviolet effects which will ruin the colours.
- Clean your table periodically. It is sufficient to wipe its surfaces using a damp cloth. For a deeper cleaning you can use any household detergent which does not contain wax or abrasives. Should you wish to further improve bars smoothness, only employ a good quality silicone spray. Please be careful not to use any vegetal or any other type of grease or you run the risk of attracting dirt.
- Should you pass on the table football set to another person, please make sure that this person is aware of the assembly and user instructions.
- Always place the table football set on even and stable surfaces.
- Before each use, check that all parts are working correctly and do not use the table football set if that is not the case.
- Always place a protective layer (cardboard or carpet) under the table legs to protect your floors.
- **CAUTION:** To avoid any problems in the assembly or fastening of the table legs, first screw on all legs loosely at the same time and only tighten them later.
- Children shall not play with the appliance. Cleaning and user maintenance shall not be made by children without supervision. Keep the appliance and its cord out of reach of children less than 8 years.
- Do not operate this or any other appliance with a damaged cord or plug or after the appliance malfunctions, has been damaged in any way, has been immersed in water or other liquid. Send the unit to the nearest authorized service centre for inspection, repair or adjustment. (ONLY qualified technicians must repair the unit).

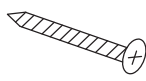
SCOPE OF SUPPLY

<p>#1</p>  <p>Side panel 2 pcs</p>	<p>#2</p>  <p>End Panel w/ Goal Box A 1 pc</p>	<p>#3</p>  <p>End Panel w/ Goal Box B 1 pc</p>	<p>#4</p>  <p>Playfield 1 pc</p>
<p>#5</p>  <p>Left Leg 2 pcs</p>	<p>#6</p>  <p>Right Leg 2 pcs</p>	<p>#7</p>  <p>Support Brace 3 pcs</p>	<p>#8</p>  <p>Leg Panel A 2 pcs</p>
<p>#9</p>  <p>Leg Panel B 4 pcs</p>	<p>#10</p>  <p>Bottom Board 1 pc</p>	<p>#11</p>  <p>1/4"720mm Support Rod 3 pcs</p>	<p>#12</p>  <p>1/4" Nut 6 pcs</p>
<p>#13</p>  <p>Leg Leveler 4 pcs</p>	<p>#14</p>  <p>Allen Key 2 pcs</p>	<p>#15</p>  <p>Ball Entry Cup 2 pcs</p>	<p>#16</p>  <p>Rod Bumpers 16 pcs</p>
<p>#17</p>  <p>Plastic Rod Washer 16 pcs</p>	<p>#18</p>  <p>PLAYER 11+11 pcs</p>	<p>#19</p>  <p>Rod Handle 8 pcs</p>	<p>#20</p>  <p>Rod End Cap 8 pcs</p>

<p>#21</p>  <p>M4X28mm BOLT 26 pcs</p>	<p>#22</p>  <p>M4 NUT 26 pcs</p>	<p>#23</p>  <p>Adapter 1 pc</p>	<p>#24</p>  <p>3-Hole Rod 4 pcs</p>
<p>#25</p>  <p>2-Hole ROD 2 pcs</p>	<p>#26</p>  <p>5-Hole ROD 2 pcs</p>	<p>#27</p>  <p>1/4" * 1-1/2" Bolt 8 pcs</p>	<p>#28</p>  <p>1/4" Washer 8 pcs</p>
<p>#29</p>  <p>5/16" * 2-5/8" Bolt 16 pcs</p>	<p>#30</p>  <p>5/16" Washer 16 pcs</p>	<p>#31</p>  <p>T3.5X45mm SCREW 8 pcs</p>	<p>#32</p>  <p>T3.5X25mm SCREW 16 pcs</p>
<p>#33</p>  <p>T3.5X12mm SCREW 16 pcs</p>	<p>#34</p>  <p>Stop Ring 4 pcs</p>	<p>#35</p>  <p>Soccer Ball 2 pcs</p>	

ASSEMBLY

Step 1

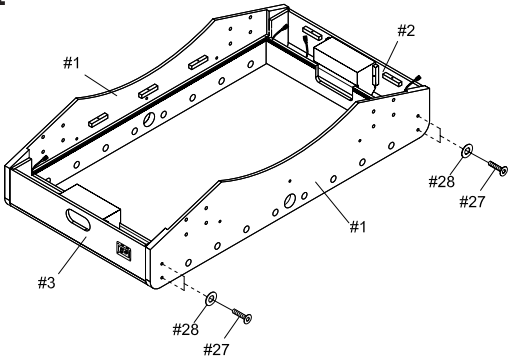

Step 2

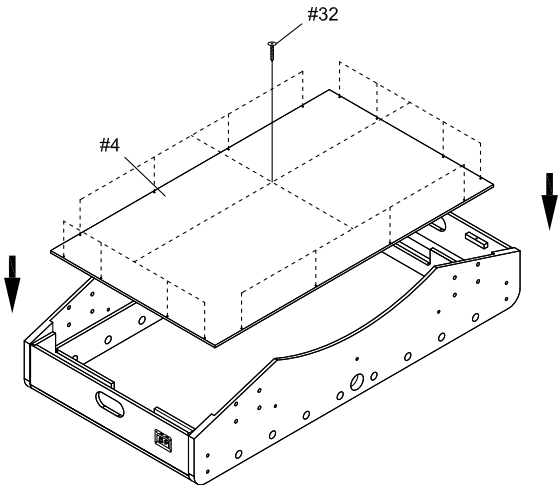

Step 3

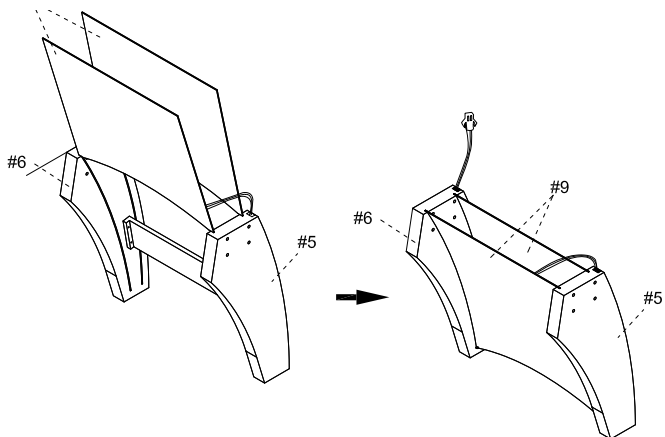

Step 4

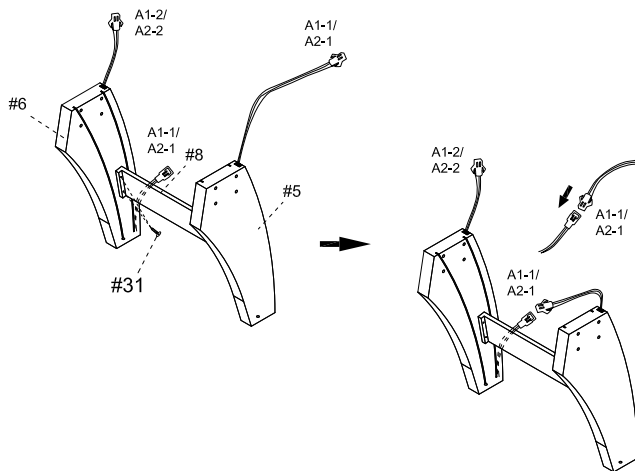

Step 5

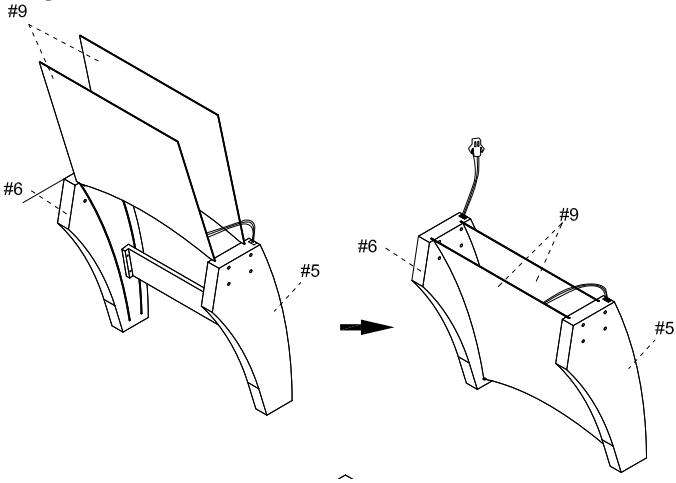

Step 6

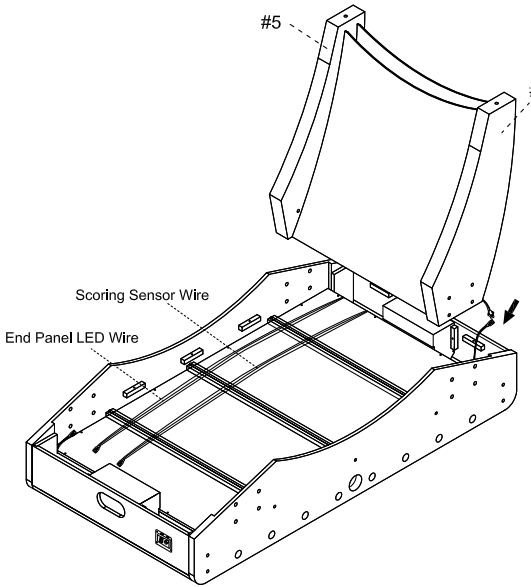

Step 7

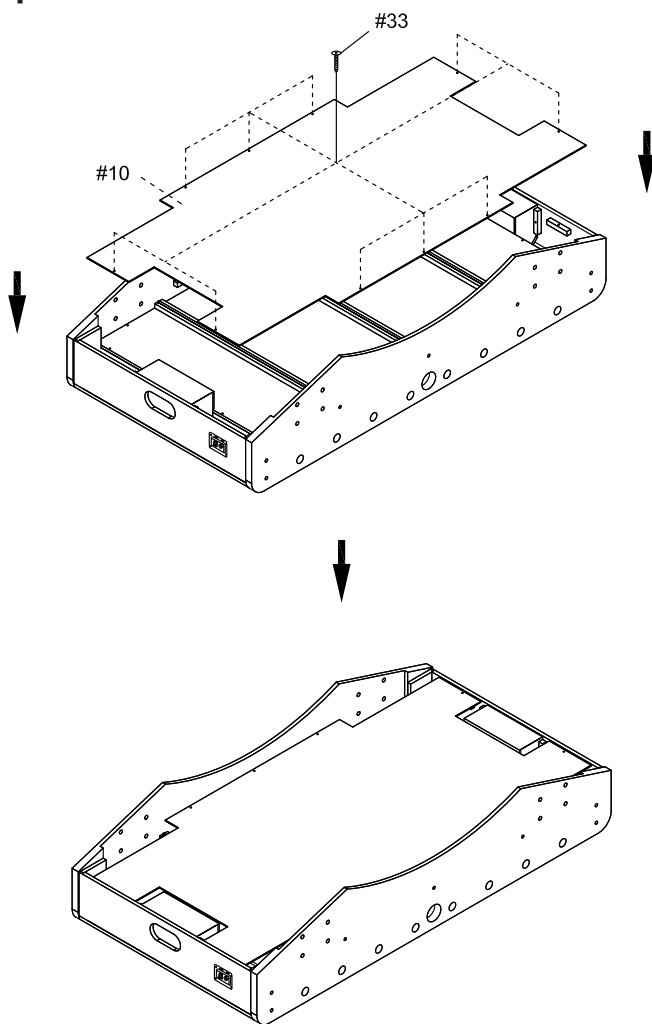

Step 8

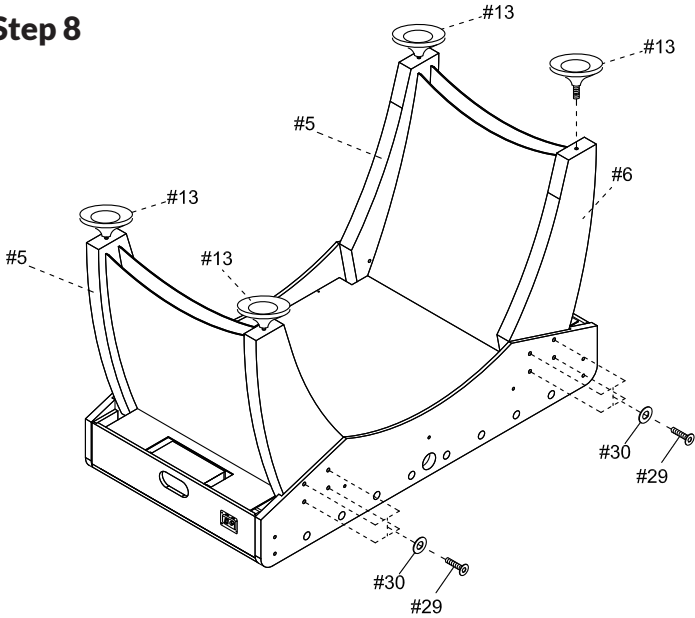

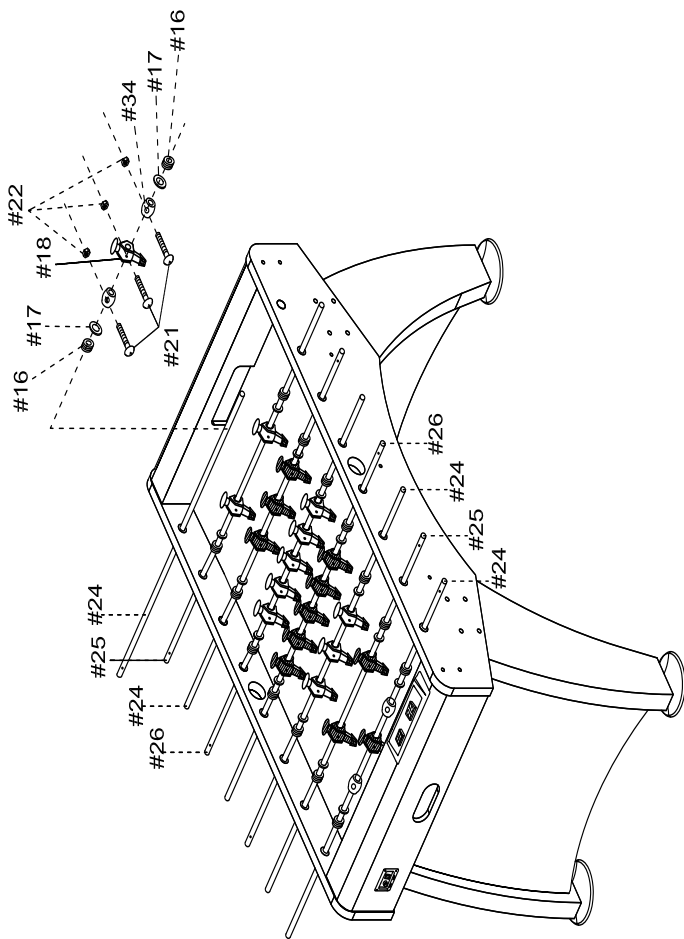

Step 9

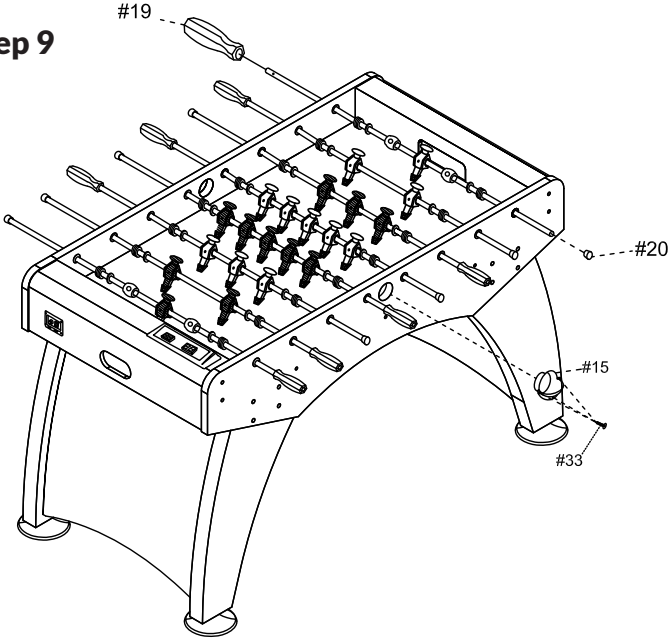

Step 10

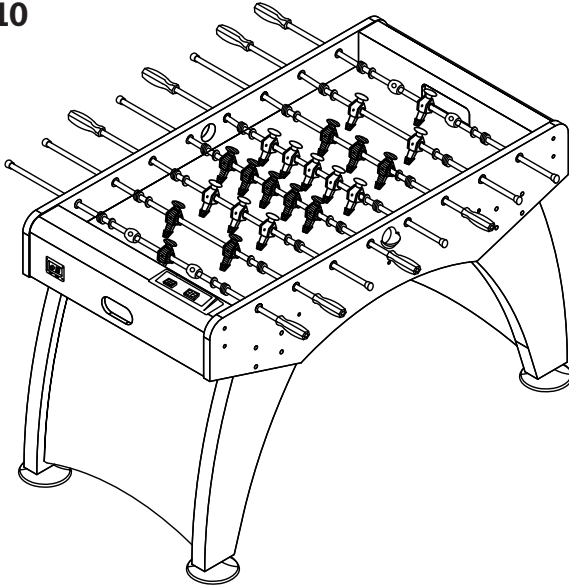

WIRING

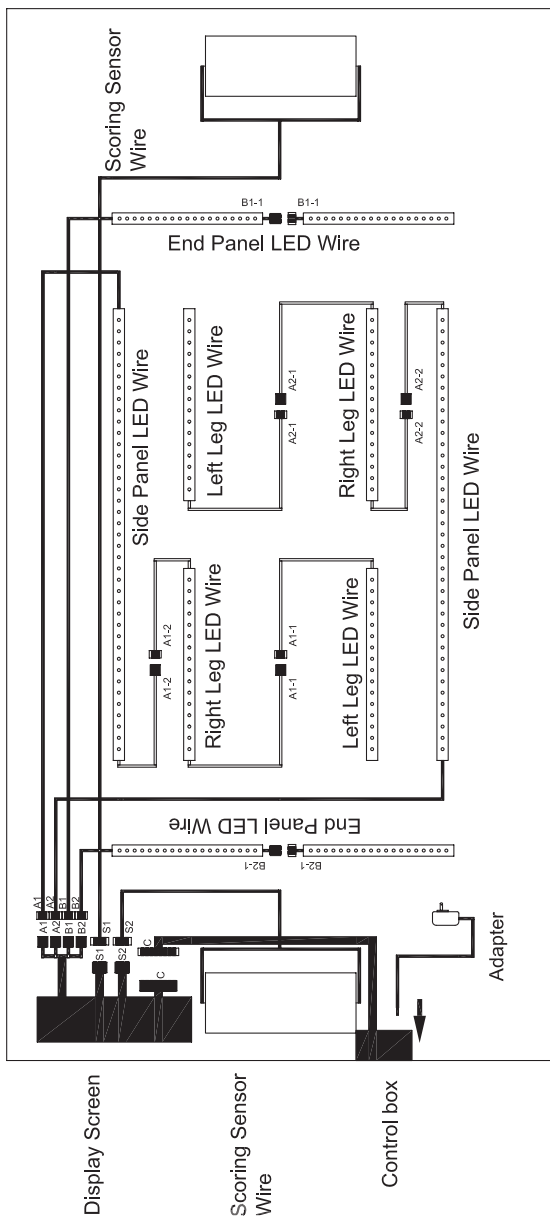

FUNCTION OF LED LIGHTS AND ELECTRONIC COUNTER

1. Take the electrical plug of the item and connect it to the wall socket in your room. All LED-lights will light up and the electronic counter will be ready for use.
2. Press the ON-button of the electronic counter. The displays of the counter will light up and will be ready for use. The counter is able to count for two player or teams from 0 to 99 goals. Each time one of the players or team shots a goal the counter will add the goal to the counting, will make a sound signal and also issue a LED light show. You can start the game at any time you want.
3. Press the RESET button if you want to stop the running game and to start a new game. Both counters will be set back to zero. You can do this at any time you want.
4. Press the OFF-button of the electronic counter to stop the game. The display of the counter will disappear. Pull out the electrical plug from the wall socket and store the soccer table safe.

CLEANING AND CARE

In order for a new table football table to retain its perfect playing characteristics, it must of course be properly cared for. The care of the kicker is mainly limited to lubricating the rods and cleaning the playing field.

Cleaning the Player Poles

To clean the poles, apply a little window cleaner to a soft cloth and clean the poles with it. You should also lubricate the poles so that they run smoothly.

Lubricating the rods

Pure silicone oil is a good lubricant. Do not apply more than one or two drops to each rod. Distribute these drops on the rod and in the bearings. If you apply too much silicone oil, it can drip and the pitch and kicker ball will become greasy.

Cleaning the pitch

Do not use aggressive detergents or cleaners that cannot be completely removed. It is therefore advisable to clean the table only with water.

If you have oily residues on the playing field, preferably use a window cleaner without special additives.

DISPOSAL CONSIDERATIONS

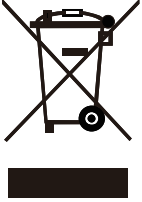

According to the European waste regulation 2012/19/EU this symbol on the product or on its packaging indicates that this product may not be treated as household waste. Instead it should be taken to the appropriate collection point for the recycling of electrical and electronic equipment. By ensuring this product is disposed of correctly, you will help prevent potential negative consequences for the environment and human health, which could otherwise be caused by inappropriate waste handling of this product. For more detailed information about recycling of this product, please contact your local council or your household waste disposal service.

DECLARATION OF CONFORMITY



Producer:

Chal-Tec GmbH, Wallstraße 16, 10179 Berlin,
Deutschland.

**This product is conform to the following
European Directives:**

2011/65/EU (RoHS)
2014/30/EU (EMV)
2014/35/EU (LVD)

Chère cliente, cher client,

Toutes nos félicitations pour l'acquisition de ce nouvel appareil. Veuillez lire attentivement et respecter les instructions de ce mode d'emploi afin d'éviter d'éventuels dommages. Nous ne saurions être tenus pour responsables des dommages dus au non-respect des consignes et à la mauvaise utilisation de l'appareil. Scannez le QR-Code pour obtenir la dernière version du mode d'emploi et des informations supplémentaires concernant le produit.



SOMMAIRE

Article 35
Consignes de sécurité 36
Contenu de la livraison 37
Montage 39
Fonctionnement de l'éclairage led et du compteur électronique 46
Schéma de branchement 47
Nettoyage et entretien 48
Informations sur le recyclage 49
Déclaration de conformité 49









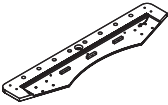
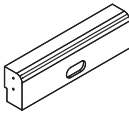
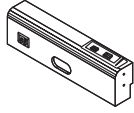
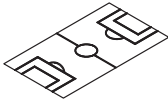
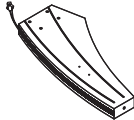
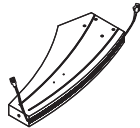

ARTICLE

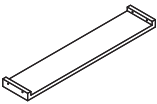
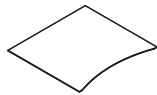
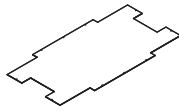
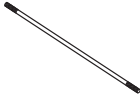





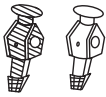

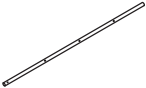
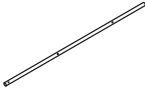
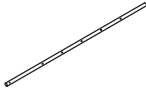

Numéro d'article	10034212, 10035491
------------------	--------------------

CONSIGNES DE SECURITÉ

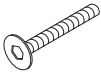
- Le montage ne doit être effectué que par des adultes. Le babyfoot assemblé est relativement grand et pourrait passer les portes difficilement. C'est pourquoi nous vous conseillons de l'assembler à son emplacement final.
- Si vous souhaitez le changer de pièce, il sera peut-être nécessaire de démonter les pieds pour les remonter ensuite.
- Ce babyfoot est destiné à un usage privé uniquement.
- Utilisez cet appareil exclusivement aux fins prévues.
- Respectez les consignes de sécurité suivantes pour garantir une longue durée de vie à votre babyfoot et une fonctionnalité optimale :
- Ne laissez pas le babyfoot à l'extérieur. La pluie, la neige et un taux d'humidité élevé endommageraient les matériaux. Une exposition prolongée à l'ensoleillement est également déconseillée en raison de l'altération possible des couleurs.
- Si vous transmettez le babyfoot à une autre personne, assurez-vous que celle-ci est informée du contenu du mode d'emploi et de la notice de montage.
- Installez toujours ce babyfoot sur une surface plane et résistante.
- Avant chaque utilisation, vérifiez la fonctionnalité de tous les éléments et n'utilisez pas le babyfoot s'ils ne sont pas en parfait état.
- Utilisez toujours un support (carton ou moquette) sous les pieds de l'appareil pour protéger votre sol.
- ATTENTION : Pour éviter les problèmes de montage ou de fixation des pieds de la table, vissez d'abord tous les pieds de la table de la même manière et fixez-les tous fermement.
- Cet appareil n'est pas destiné à être utilisé par des personnes (y compris des enfants) ayant des capacités physiques, sensorielles ou mentales réduites ou dénuées de l'expérience et des connaissances suffisantes, à moins d'avoir reçu des instructions d'une personne responsable de leur sécurité pour l'utilisation de l'appareil.
- Ne pas utiliser l'appareil avec un connecteur endommagé. De même lorsque l'appareil ne fonctionne pas, est endommagé d'une manière ou d'une autre, a été immergé dans de l'eau ou dans un autre liquide. Dans ce cas, envoyez l'appareil à l'adresse mentionnée pour réparation ou inspection.

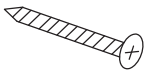
CONTENU DE LA LIVRAISON

<p>#1</p>  <p>Panneau latéral 2 x</p>	<p>#2</p>  <p>Panneau frontal avec but 1x</p>	<p>#3</p>  <p>Panneau frontal avec but 1x</p>	<p>#4</p>  <p>Terrain de jeu 1x</p>
<p>#5</p>  <p>Pied gauche 2 x</p>	<p>#6</p>  <p>Pied droit 2 x</p>	<p>#7</p>  <p>Support 3 x</p>	<p>#8</p>  <p>Traverse A 2 x</p>
<p>#9</p>  <p>Traverse B 4 lx</p>	<p>#10</p>  <p>Planche de fond 1x</p>	<p>#11</p>  <p>Stabilisateur 1/4"720mm 3 x</p>	<p>#12</p>  <p>Manchon Allen à 1/4" visser 6 x</p>
<p>#13</p>  <p>Vis de pied 4 x</p>	<p>#14</p>  <p>Clé Allen 2 x</p>	<p>#15</p>  <p>Support de balle 2 x</p>	<p>#16</p>  <p>Amortisseur caoutchouc pour barre 16 x</p>
<p>#17</p>  <p>Rondelle en plastique 16 x</p>	<p>#18</p>  <p>joueurs 11+11 x</p>	<p>#19</p>  <p>Poignée de barre jeu 8 x</p>	<p>#20</p>  <p>Capuchon 8 x</p>

<p>#21</p>  <p>M4X28mm vis 26 x</p>	<p>#22</p>  <p>M4 écrou 26 x</p>	<p>#23</p>  <p>adaptateur secteur 1 x</p>	<p>#24</p>  <p>barre de 3 joueurs 4 x</p>
<p>#25</p>  <p>barre de 2 joueurs 2 x</p>	<p>#26</p>  <p>barre de 5 joueurs 2 x</p>	<p>#27</p>  <p>1/4" * 1-1/2" Vis 8 x</p>	<p>#28</p>  <p>rondelle 8 x</p>
<p>#29</p>  <p>vis de barre de 2 joueurs 16 x</p>	<p>#30</p>  <p>5/16" rondelle 16 x</p>	<p>#31</p>  <p>vis T3.5X45mm 8 x</p>	<p>#32</p>  <p>vis T3.5X25mm 16 x</p>
<p>#33</p>  <p>vis T3.5X12mm 16 x</p>	<p>#34</p>  <p>Anneau bloqueur 4 x</p>	<p>#35</p>  <p>balle 2 x</p>	

MONTAGE

Étape 1

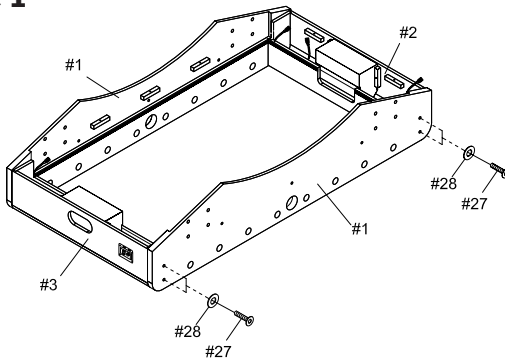

Étape 2

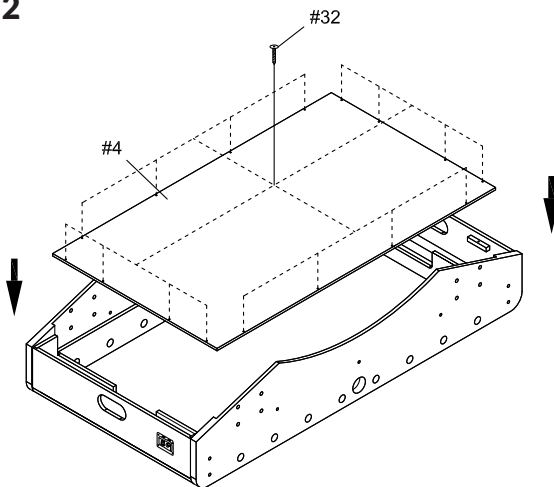

Étape 3

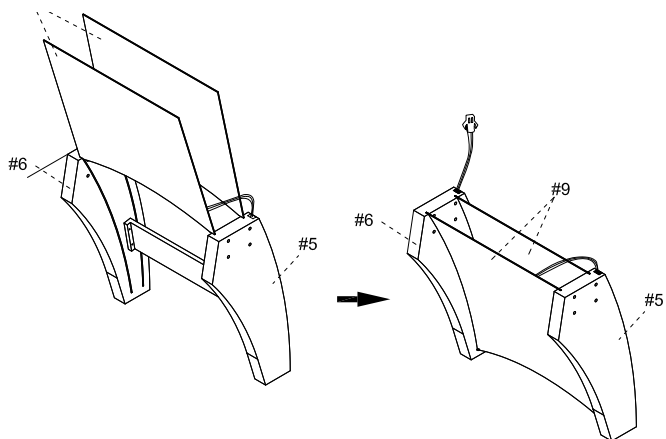

Étape 4

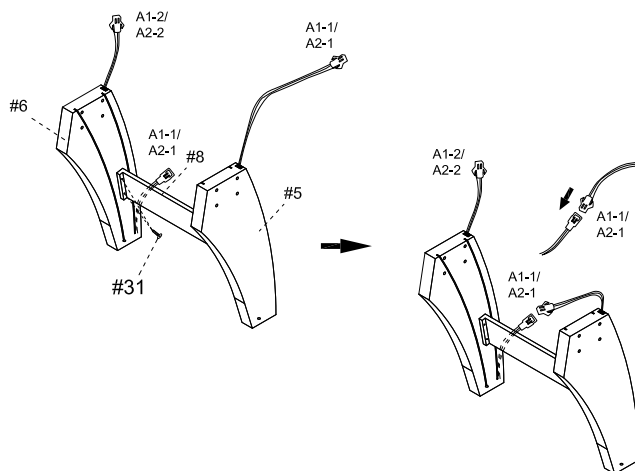

Étape 5

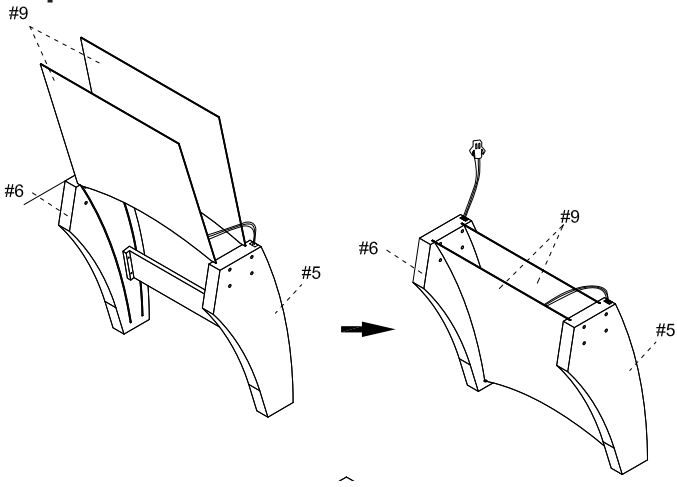

Étape 6

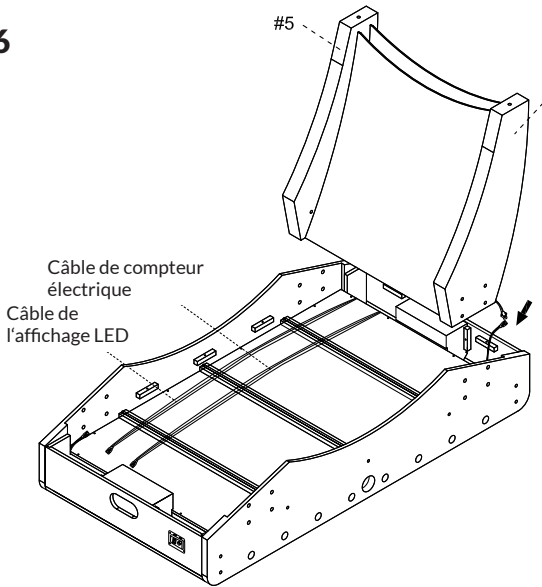

Étape 7

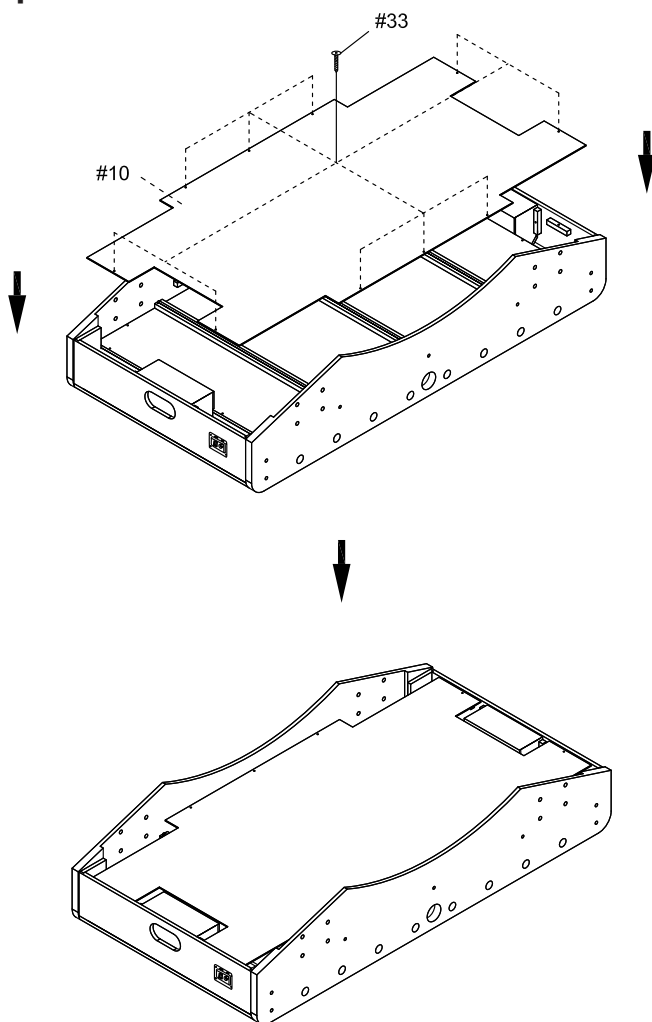

Étape 8

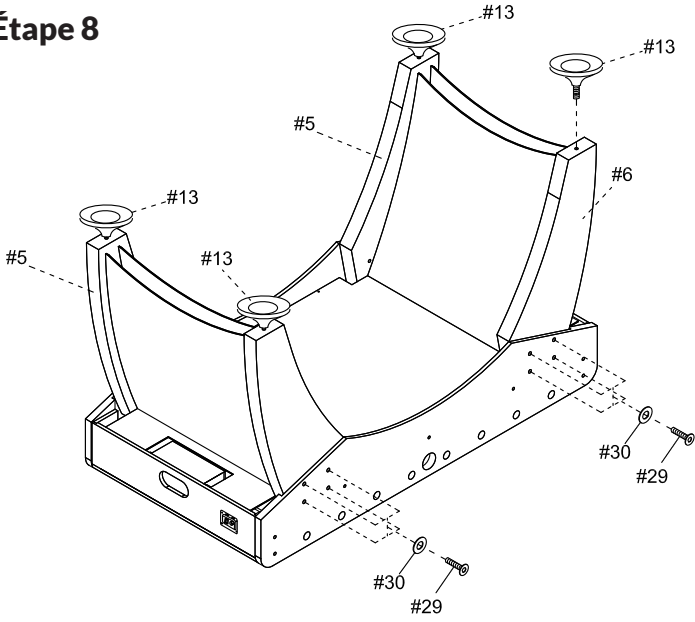

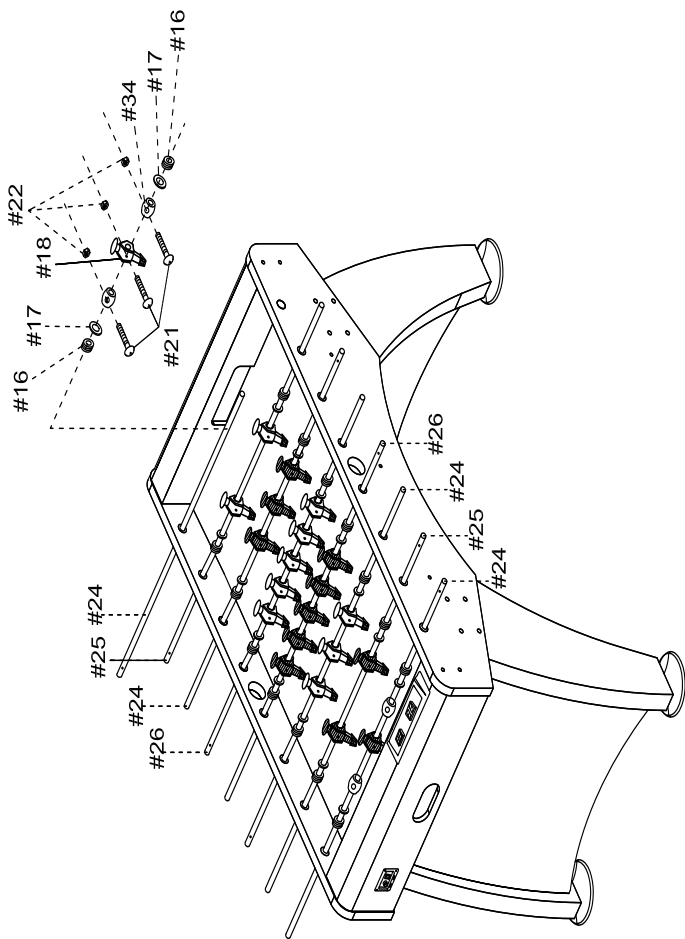

Étape 9

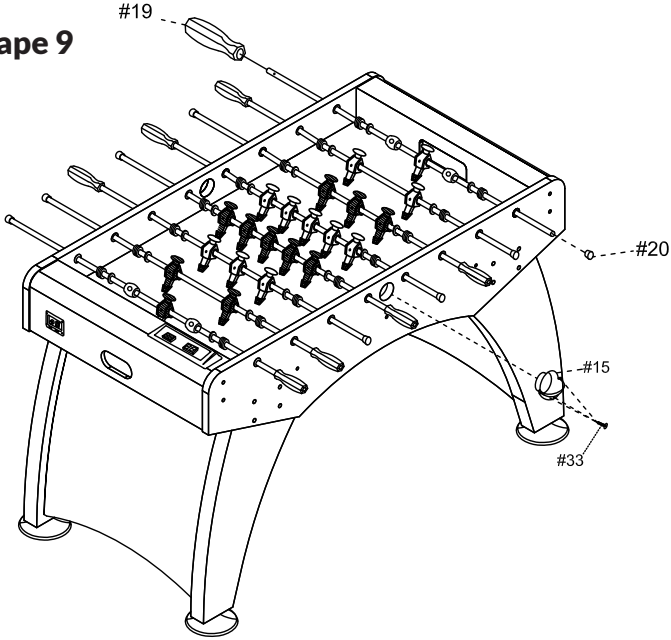

Étape 10

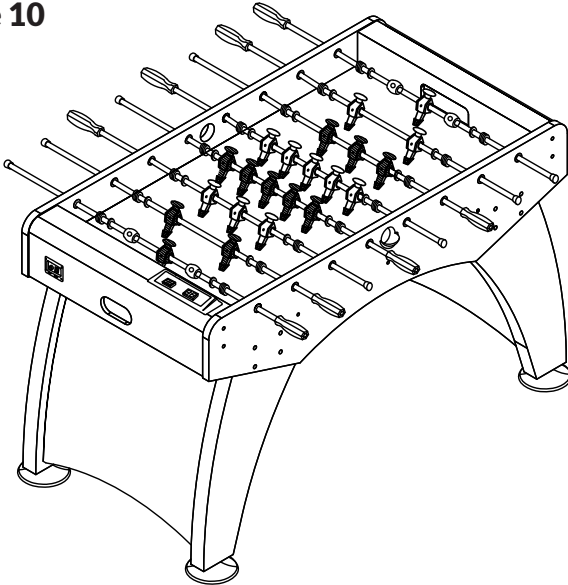

FONCTIONNEMENT DE L'ÉCLAIRAGE LED ET DU COMPTEUR ÉLECTRONIQUE

Branchez la fiche secteur de l'appareil à la prise de votre chambre. Tous les voyants s'allument et le compteur électronique est prêt à fonctionner.

Appuyez sur la touche ON du compteur électronique. Les affichages de la bande s'allument et sont prêts à être utilisés. Le compteur peut compter les points pour deux joueurs ou équipes de 0 à 99 buts. Chaque fois qu'un joueur ou une équipe marque un but, émet un signal sonore et également une lumière LED. Vous pouvez commencer le jeu à tout moment.

Appuyez sur la touche RESET si vous voulez arrêter la partie en cours et commencer une nouvelle partie. Les deux compteurs sont remis à zéro. Vous pouvez le faire à tout moment.

Appuyez sur la touche OFF du compteur électronique pour arrêter la partie. L'affichage du compteur s'éteint. Débranchez la prise d'alimentation de la prise et mettez la table de babyfoot en sécurité.

SCHÉMA DE BRANCHEMENT

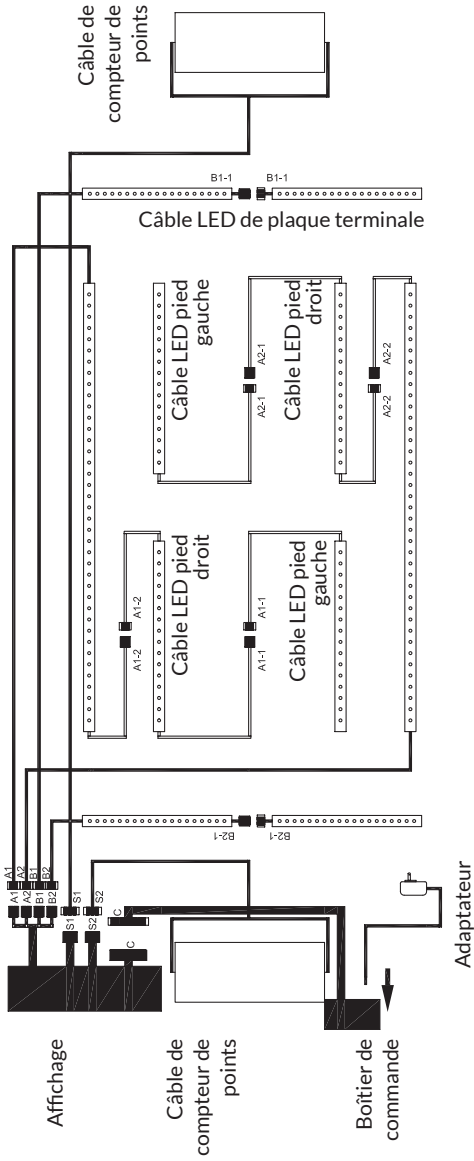

NETTOYAGE ET ENTRETIEN

Bien sûr, pour qu'un babyfoot neuf conserve ses caractéristiques de jeu parfaites, il doit donc être soigneusement entretenu. L'entretien du babyfoot se limite principalement à la lubrification des barres de joueurs et au nettoyage du terrain.

Nettoyage des barres de joueurs

Pour nettoyer les barres, mettez un peu de produit pour vitres sur un chiffon doux et essuyez les barres. Lubrifiez aussi les barres pour qu'elles glissent parfaitement.

Lubrification des barres de joueurs

L'huile de silicone pure est un bon lubrifiant. Ne mettez pas plus d'une ou deux gouttes sur chaque barre. Répartissez ensuite ces gouttes sur la barre et les paliers. Si vous appliquez trop d'huile de silicone, elle risque de couler et le terrain de jeu ainsi que la balle seraient gras.

Nettoyage du terrain de jeu

Ne pas utiliser des produits de nettoyage agressifs ou qui ne peuvent pas se retirer complètement. Par conséquent, nettoyez la table uniquement avec de l'eau.

Si vous avez des résidus graisseux sur le terrain de jeu, utilisez de préférence un nettoyant pour vitres sans additifs spéciaux.

INFORMATIONS SUR LE RECYCLAGE

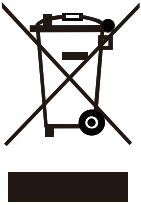

Vous trouverez sur le produit l'image ci-contre (une poubelle sur roues, barrée d'une croix), ce qui indique que le produit se trouve soumis à la directive européenne 2012/19/UE. Renseignez-vous sur les dispositions en vigueur dans votre région concernant la collecte séparée des appareils électriques et électroniques. Respectez-les et ne jetez pas les appareils usagés avec les ordures ménagères. La mise en rebut correcte du produit usagé permet de préserver l'environnement et la santé. Le recyclage des matériaux contribue à la préservation des ressources naturelles.

DÉCLARATION DE CONFORMITÉ

Fabricant :

Chal-Tec GmbH, Wallstraße 16, 10179 Berlin,
Allemagne



Ce produit est conforme aux directives européennes suivantes :

2011/65/EU (RoHS)
2014/30/EU (EMV)
2014/35/EU (LVD)

Gentile cliente,

ti facciamo le nostre congratulazioni per l'acquisto del tuo dispositivo. Leggere attentamente le seguenti istruzioni e seguirle per evitare possibili danni. Non ci assumiamo alcuna responsabilità per danni causati dall'inosservanza delle istruzioni e dall'uso improprio. Scansionate il seguente codice QR per accedere al manuale più recente e ad altre informazioni sul prodotto.



INDICE

Articolo 51
Istruzioni di sicurezza 52
Volume di fornitura 53
Montaggio 55
Funzione di luce led e contatore elettronico 62
Schema elettronico 63
Pulizia e cura 64
Indicazioni sullo smaltimento 65
Dichiarazione di conformità 65









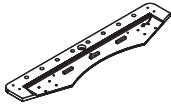
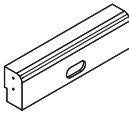
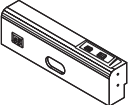
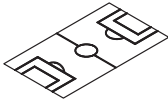
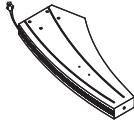
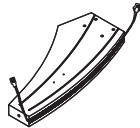

ARTICOLO

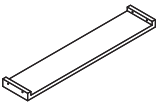
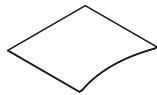
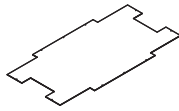
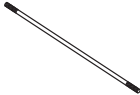





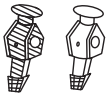

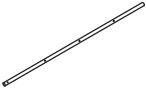
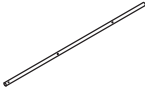
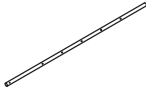

Numero articolo	10034212, 10035491
-----------------	--------------------

ISTRUZIONI DI SICUREZZA

- L'installazione può essere eseguita solo da un adulto. Il tavolo è di dimensioni relativamente grandi e non potrebbe non passare tra le porte. Pertanto, si consiglia di assemblare il tavolo di biliardino nella stanza in cui si desidera giocare.
- Se si desidera spostare il tavolo da gioco in un'altra stanza, potrebbe essere necessario rimuovere prima le gambe e quindi reinstallarle.
- Questo biliardino è solo per uso privato.
- Utilizzare questo dispositivo solo per lo scopo previsto.
- Attenersi alle seguenti istruzioni di sicurezza per garantire una lunga durata e una funzionalità ottimale del tavolo di biliardino:
- Non lasciare il biliardino fuori. Pioggia, neve e alta umidità danneggiano il materiale. Non è raccomandata neppure un'esposizione più lunga alla luce solare a causa dell'effetto sbiadente sui colori.
- Se si trasmette il biliardino ad un'altra persona, assicurarsi che la persona conosca il contenuto delle istruzioni di installazione e di funzionamento.
- Posizionare sempre questo biliardino su una superficie piana e stabile.
- Prima di ogni utilizzo, è necessario controllare tutte le parti per la loro funzione e, se non sono di uso perfetto, non utilizzare il biliardino.
- Utilizzare sempre un tappetino (cartone o moquette) sotto le gambe dell'unità per proteggere l'attrezzatura.
- **ATTENZIONE:** per evitare problemi durante il montaggio o il fissaggio delle gambe del tavolo, avvitare prima tutte le gambe del tavolo allo stesso modo e infine stringere per bene.
- Questo dispositivo non è destinato all'uso da parte di persone (compresi i bambini) che hanno ridotte capacità fisiche, sensoriali o mentali o che non hanno esperienza e conoscenza sufficienti; a meno che non abbiano ricevuto istruzioni da parte di una persona responsabile della loro sicurezza per l'uso del dispositivo.
- Non utilizzare il dispositivo con una spina danneggiata. Nemmeno quando il dispositivo non funziona, è stato danneggiato in qualche modo, veniva immerso in acqua o altro liquido. In questo caso, inviare il dispositivo all'indirizzo specificato per la riparazione o l'ispezione.

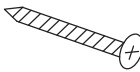
VOLUME DI FORNITURA

<p>#1</p>  <p>pannello laterale 2 x</p>	<p>#2</p>  <p>Parte frontale con cancello 1x</p>	<p>#3</p>  <p>Parte frontale con cancello 1x</p>	<p>#4</p>  <p>Campo da gioco 1x</p>
<p>#5</p>  <p>gamba sinistra 2 x</p>	<p>#6</p>  <p>gamba destra 2 x</p>	<p>#7</p>  <p>staffa di supporto 3 x</p>	<p>#8</p>  <p>Pedana A 2x</p>
<p>#9</p>  <p>Pedana B 4 lx</p>	<p>#10</p>  <p>Piastra sotto bordo 1x</p>	<p>#11</p>  <p>Stabilizzatore 1/4"720mm 3 x</p>	<p>#12</p>  <p>Vite esagonale 1/4" internamente 6x</p>
<p>#13</p>  <p>vite calante 4 x</p>	<p>#14</p>  <p>Chiave esagonale 2x</p>	<p>#15</p>  <p>Balla ricevente 2 x</p>	<p>#16</p>  <p>Asta di gioco con cuscinetto in gomma 16x</p>
<p>#17</p>  <p>Rondella di plastica 16 x</p>	<p>#18</p>  <p>Pedine 11+11 x</p>	<p>#19</p>  <p>Manico per asta da gioco 8 x</p>	<p>#20</p>  <p>Tappo di chiusura 8 x</p>

<p>#21</p>  <p>M4X28mm Viti 26 x</p>	<p>#22</p>  <p>M4Dado 26 x</p>	<p>#23</p>  <p>Alimentatore 1 x</p>	<p>#24</p>  <p>3-Asta da gioco 4 x</p>
<p>#25</p>  <p>2--Asta da gioco 2 x</p>	<p>#26</p>  <p>5-Asta da gioco 2 x</p>	<p>#27</p>  <p>1/4" *1-1/2" Viti 8 x</p>	<p>#28</p>  <p>Rondella 8 x</p>
<p>#29</p>  <p>2 Asta da gioco 16 x</p>	<p>#30</p>  <p>5/16" Rondella 16 x</p>	<p>#31</p>  <p>Vite T3.5X45mm 8 x</p>	<p>#32</p>  <p>Vite T3.5X25mm 16 x</p>
<p>#33</p>  <p>Vite T3.5X12mm 16 x</p>	<p>#34</p>  <p>Stopper Porta 4 x</p>	<p>#35</p>  <p>Palla 2 x</p>	

MONTAGGIO

Passo 1

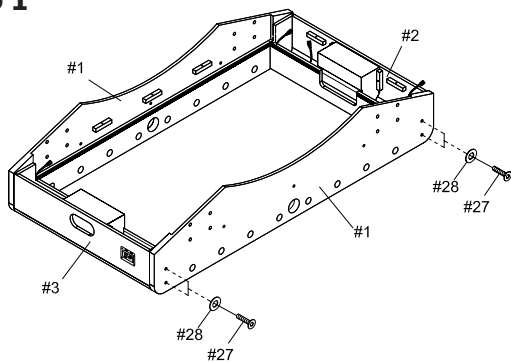

Passo 2

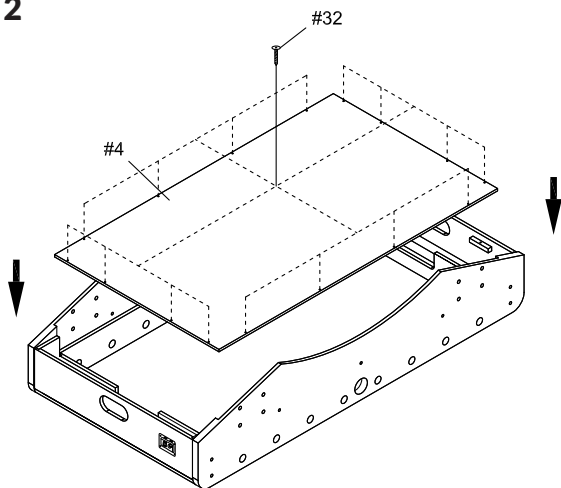

Passo 3

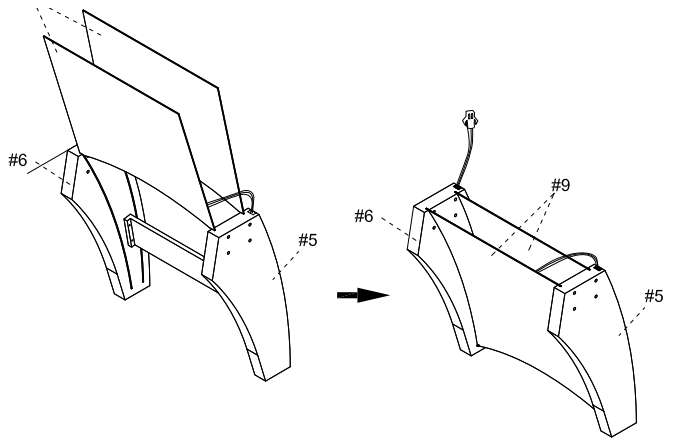

Passo 4

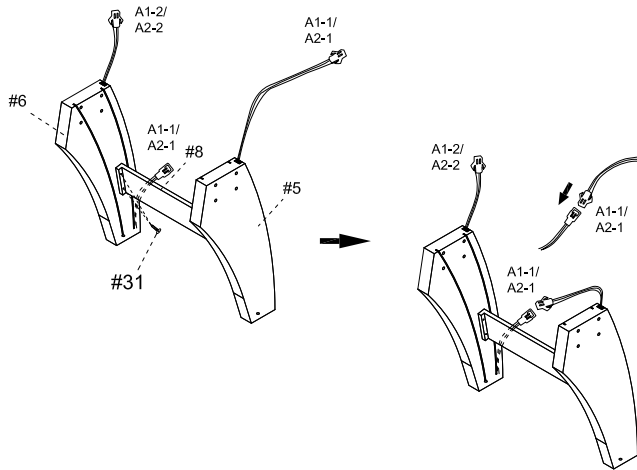

Passo 5

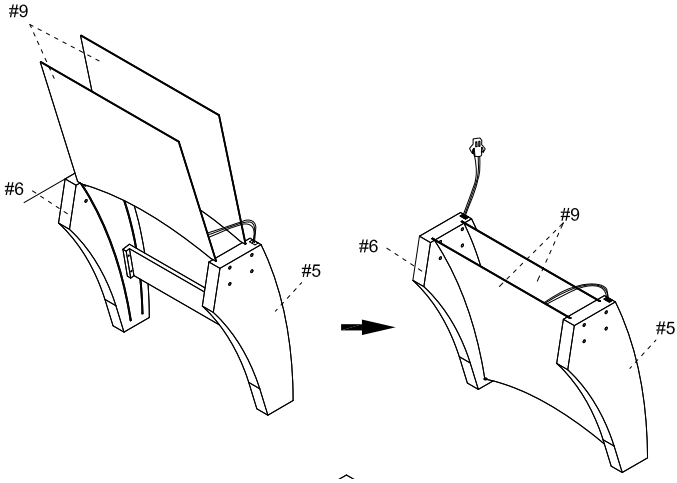

Passo 6

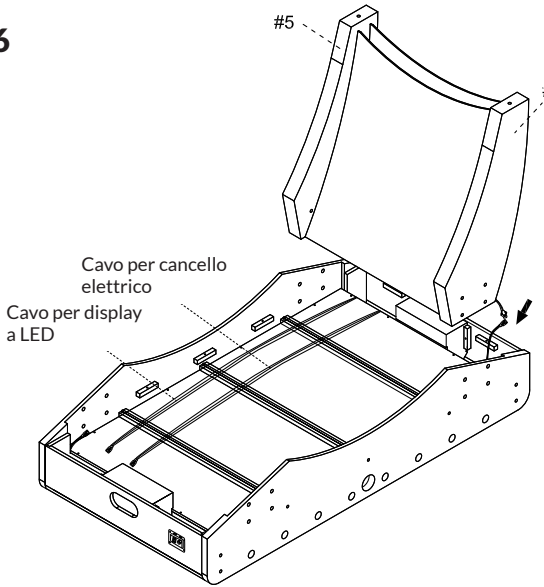

Passo 7

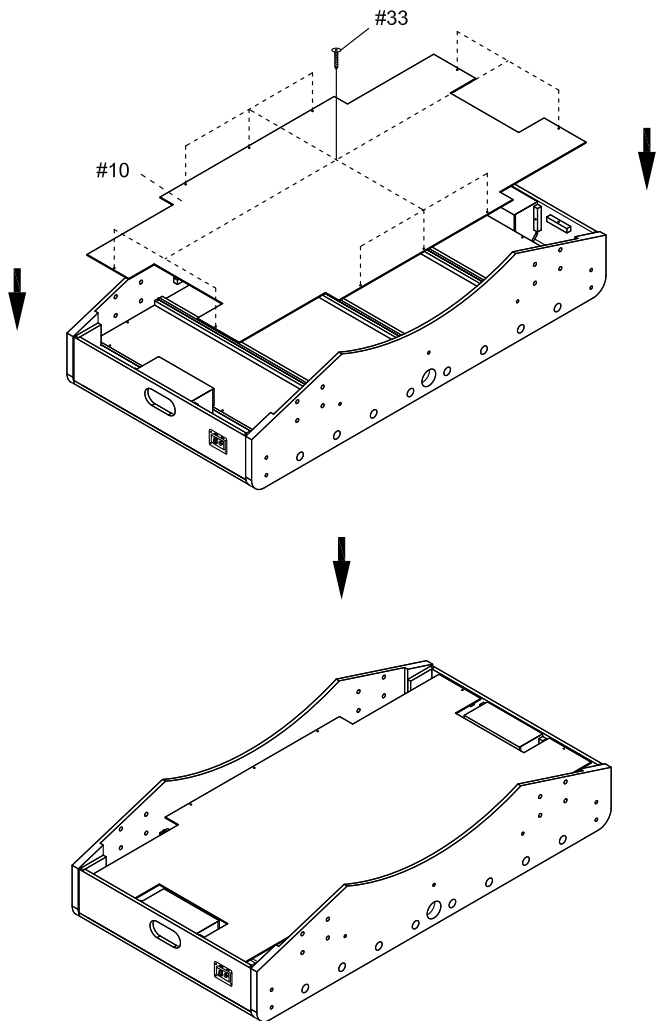

Passo 8

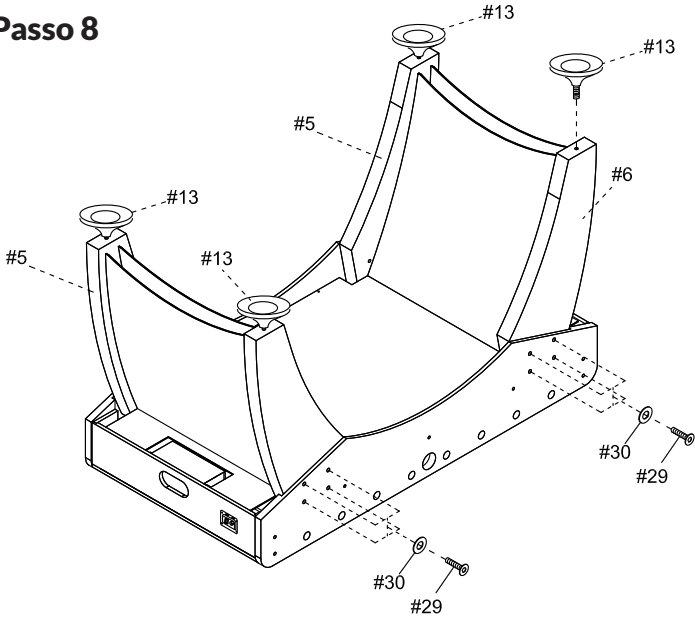

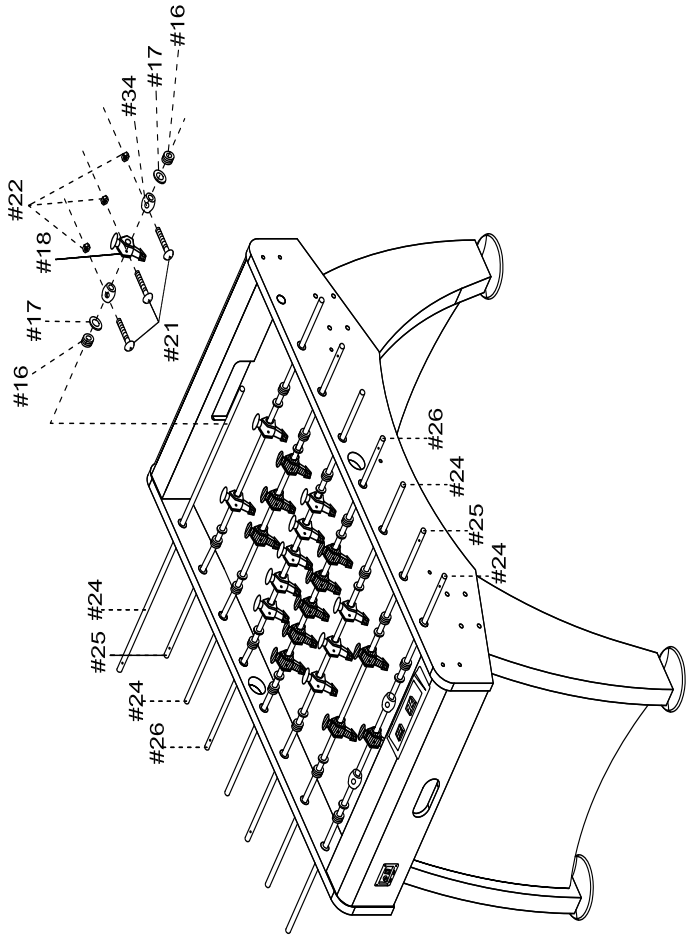

Passo 9

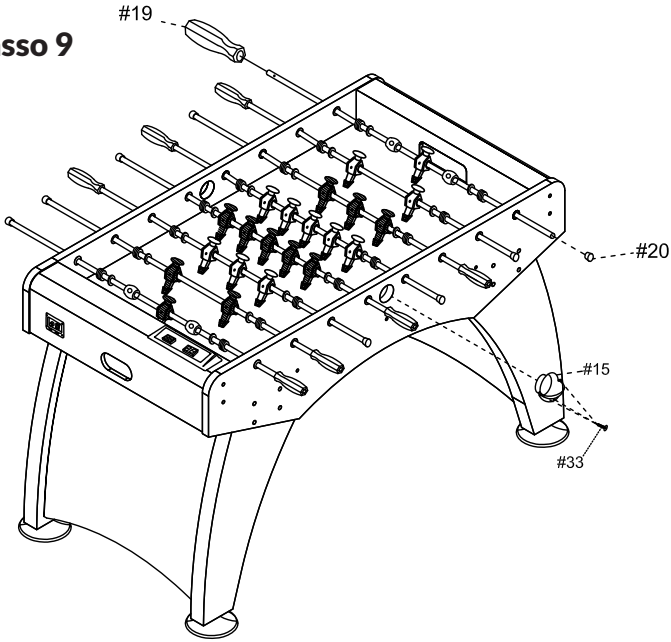

Passo 10

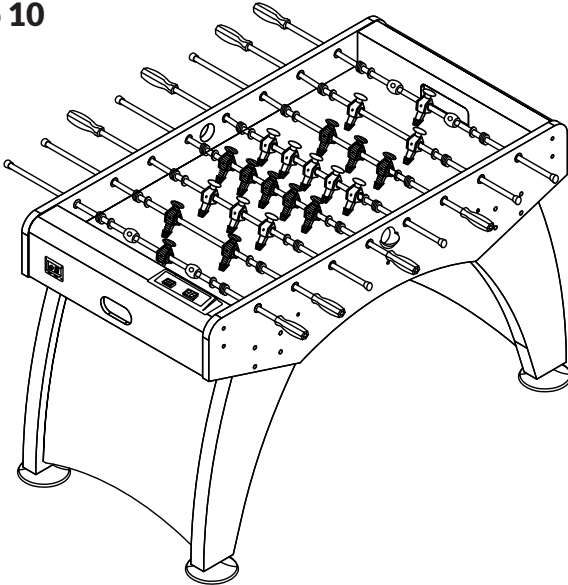

FUNZIONE DI LUCE LED E CONTATORE ELETTRONICO

Prendere la spina di alimentazione del dispositivo e collegarla alla presa nella propria stanza. Tutte le luci a LED si accendono e il contatore elettronico è pronto per l'uso.

Premere il pulsante ON del contatore elettronico. I display della barra si illuminano e sono pronti per l'uso. Il contatore è in grado di contare per due giocatori o squadre da 0 a 99 goal. Ogni volta che uno dei giocatori o una squadra segna un goal, il contatore aggiunge il punteggio al conteggio, emette un segnale acustico ed emette anche uno spettacolo di luci a LED. Puoi iniziare il gioco in qualsiasi momento.

Premere il pulsante RESET se si desidera interrompere la partita corrente e iniziare una nuova partita. Entrambi i contatori vengono azzerati. Questo si può fare in qualsiasi momento.

Premi il pulsante OFF sul contatore elettronico per fermare il gioco. Il display del contatore si spegne. Scollegare la spina di alimentazione dalla presa e tenere al sicuro il biliardino.

SCHEMA ELETTRICO

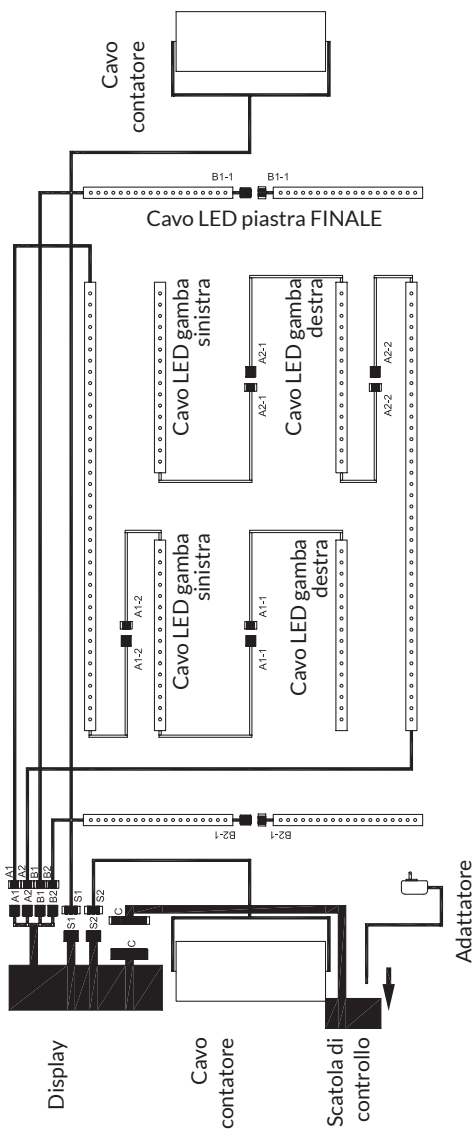

PULIZIA E CURA

Affinché un nuovo biliardino possa mantenere le sue caratteristiche di gioco perfette, deve essere ovviamente ben curato. La cura del biliardino è limitata principalmente alla lubrificazione delle aste da gioco e alla pulizia del campo da gioco.

Pulizia delle aste da gioco

Per pulire le aste, mettere un po' di detergente per vetri su un panno morbido e spazzolare le aste. Inoltre, lubrificare ancora le aste, in modo che abbiano un funzionamento ottimale.

Lubrificazione delle aste da gioco

L'olio di silicone puro funziona molto bene come lubrificante. Non mettere più di una o due gocce su ogni asta. Queste gocce vengono quindi distribuite sull'asta e nei bordi. Se si applica troppo olio di silicone, potrebbe gocciolare e il campo da gioco e la palla da calcio potrebbero ungere.

Pulizia del campo da gioco

Non cercare detergenti aggressivi o detergenti che non possono essere completamente rimossi. Pertanto, la pulizia del tavolo è consigliata solo con acqua.

Se si hanno residui oleosi sul campo da gioco, utilizzare preferibilmente un detergente per vetri senza additivi speciali.

INDICAZIONI SULLO SMALTIMENTO



Se l'illustrazione a sinistra (bidone della spazzatura barrato da una croce) si trova sul prodotto, si applica la Direttiva europea 2012/19 / UE. Questi prodotti non devono essere smaltiti insieme ai normali rifiuti domestici. Scopri le normative locali per la raccolta differenziata di apparecchiature elettriche ed elettroniche. Seguire le normative locali e non gettare i vecchi elettrodomestici nei rifiuti domestici. Lo smaltimento conforme delle vecchie apparecchiature protegge l'ambiente e la salute di altre persone da possibili conseguenze negative. Il riciclaggio dei materiali aiuta a ridurre il consumo di materie prime.

DICHIARAZIONE DI CONFORMITÀ

Produttore:

Chal-Tec GmbH, Wallstraße 16, 10179 Berlin,
Germania.



Questo prodotto è conforme alle seguenti direttive europee:

2011/65 / UE (RoHS)

2014/30 / UE (EMC)

2014/35 / UE (LVD))

Estimado cliente:

Le felicitamos por la adquisición de este producto. Lea atentamente el siguiente manual y siga cuidadosamente las instrucciones de uso con el fin de evitar posibles daños. La empresa no se responsabiliza de los daños ocasionados por un uso indebido del producto o por haber desatendido las indicaciones de seguridad. Escanee el código QR para obtener acceso al manual de usuario más reciente y otra información sobre el producto.



ÍNDICE

Artículo 67

Indicaciones de seguridad 68

Envío 69

Montaje 71

Función de las luces led y números electrónicos 78

Esquema de circuitos 79

Limpieza y cuidado 80

Retirada del aparato 81

Declaración de conformidad 81









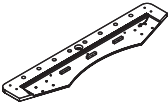
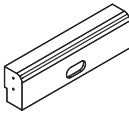
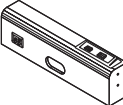
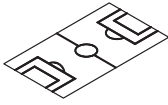
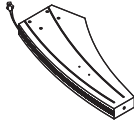
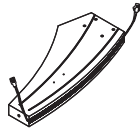

ARTÍCULO

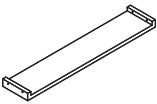
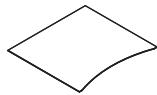
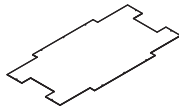
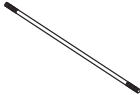





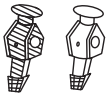

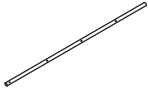
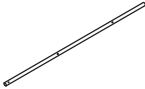
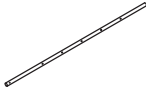
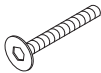

Número de artículo	10034212, 10035491
--------------------	--------------------

INDICACIONES DE SEGURIDAD

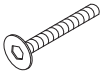
- Solamente los adultos deben montar el futbolín. El artículo montado es relativamente grande en tamaño y podría no pasar por la puerta. Por ello, se recomienda montar el futbolín directamente en la sala en la que se jugará.
- Si desea mover el futbolín a otra habitación, es posible que primero deba desmontar las patas y luego volver a montarlas.
- El futbolín solo es apto para uso privado.
- Utilice este artículo solamente con el fin para el cual ha sido concebido.
- Siga las siguientes indicaciones de seguridad para garantizar una larga vida útil y una óptima funcionalidad del futbolín:
- No utilice el futbolín al aire libre. La lluvia, nieve y alta humedad dañan el material. Tampoco se recomienda una exposición prolongada a la luz solar, ya que los colores pierden su intensidad.
- Si entrega el futbolín a otra persona, asegúrese de que esté familiarizada con el contenido de las instrucciones de montaje y funcionamiento.
- Monte el futbolín sobre una superficie nivelada y estable.
- Antes de cada uso, compruebe el funcionamiento de todas las piezas y no utilice el futbolín si no está en perfecto estado de funcionamiento.
- Utilice siempre una base (de cartón o alfombra) debajo de las patas del artículo para proteger sus muebles.
- **ATENCIÓN:** Para evitar problemas al montar o fijar las patas de la mesa, primero atornille todas las patas de la mesa y luego apriételas.
- Los niños y las personas con discapacidad física, psíquica o sensorial, o carentes de la experiencia y conocimiento necesarios podrán utilizar el aparato si han sido previamente instruidos por su tutor o supervisor sobre el funcionamiento del mismo y conocen las funciones, así como las indicaciones de seguridad.
- No utilice el futbolín si el cable de alimentación está dañado. No utilice el futbolín si no funciona, ha sido dañado de alguna manera o si fue sumergido en agua o cualquier otro líquido. En este caso, envíe el futbolín a la dirección especificada para su reparación o verificación.

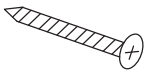
ENVÍO

<p>#1</p>  <p>Parte lateral 2 x</p>	<p>#2</p>  <p>Parte frontal con portería 1x</p>	<p>#3</p>  <p>Parte frontal con portería 1x</p>	<p>#4</p>  <p>Campo 1x</p>
<p>#5</p>  <p>Pata izquierda 2 x</p>	<p>#6</p>  <p>Pata derecha 2 x</p>	<p>#7</p>  <p>Soporte 3 x</p>	<p>#8</p>  <p>Placa de la pata A 2 x</p>
<p>#9</p>  <p>Placa de la pata B 4 lx</p>	<p>#10</p>  <p>Tabla inferior 1x</p>	<p>#11</p>  <p>Barra de soporte 1/4"720mm 3 x</p>	<p>#12</p>  <p>Casquillo de 1/4" hexágono interior 6 x</p>
<p>#13</p>  <p>Tornillo de pata 4 x</p>	<p>#14</p>  <p>Llave hexagonal 2 x</p>	<p>#15</p>  <p>Copa receptora de la bola 2 x</p>	<p>#16</p>  <p>Tope de goma para la barra rotante 16 x</p>
<p>#17</p>  <p>Arandela de plástico 16 x</p>	<p>#18</p>  <p>Muñecos 11+11 x</p>	<p>#19</p>  <p>Agarre 8 x</p>	<p>#20</p>  <p>Tapa de extremo 8 x</p>

<p>#21</p>  <p>M4X28mm Tornillo 26 x</p>	<p>#22</p>  <p>M4 Tuerca 26 x</p>	<p>#23</p>  <p>Adaptador 1 x</p>	<p>#24</p>  <p>3-Barra rotante 4 x</p>
<p>#25</p>  <p>2-Barra rotante 2 x</p>	<p>#26</p>  <p>5-Barra rotante 2 x</p>	<p>#27</p>  <p>1/4" *1-1/2" Tornillo 8 x</p>	<p>#28</p>  <p>Arandela 8 x</p>
<p>#29</p>  <p>Tornillo 16 x</p>	<p>#30</p>  <p>5/16" Arandela 16 x</p>	<p>#31</p>  <p>Tornillo T3.5X45mm 8 x</p>	<p>#32</p>  <p>Tornillo T3.5X25mm 16 x</p>
<p>#33</p>  <p>Tornillo T3.5X12mm 16 x</p>	<p>#34</p>  <p>Tope de meta 4 x</p>	<p>#35</p>  <p>Bola 2 x</p>	

MONTAJE

Paso 1

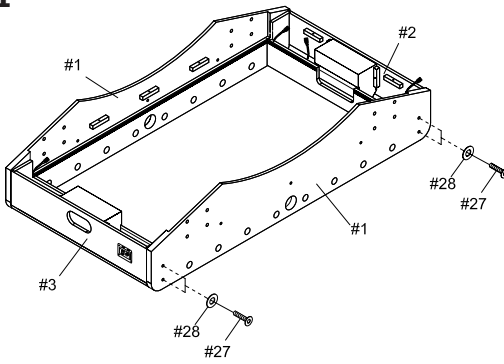

Paso 2

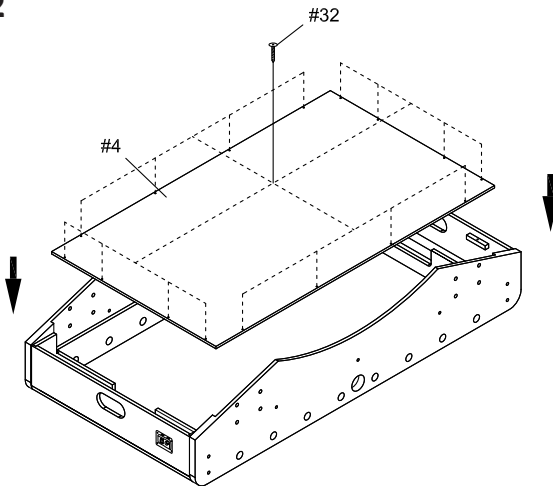

Paso 3

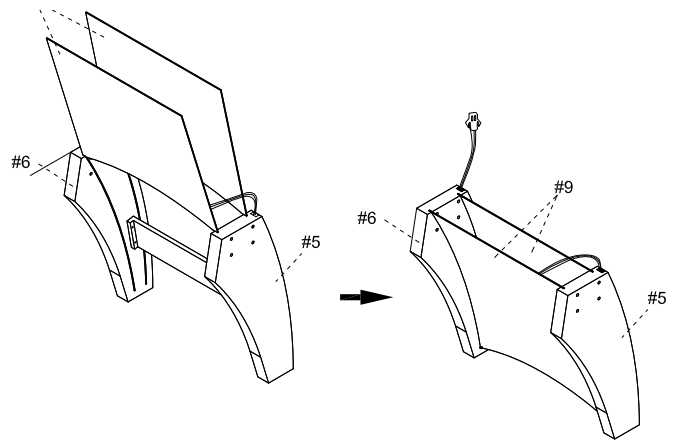

Paso 4

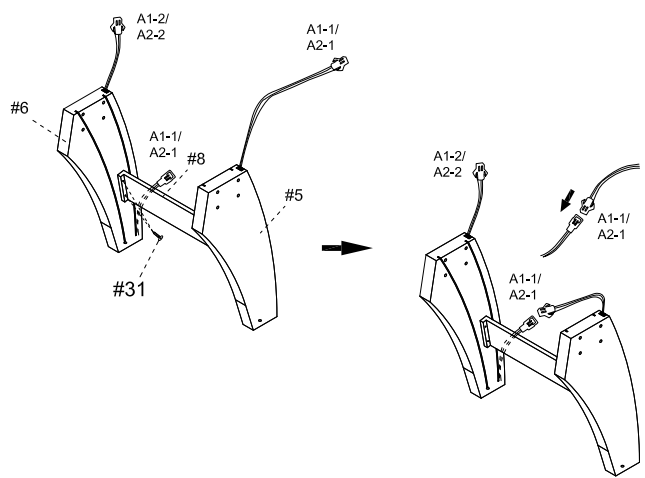

Paso 5

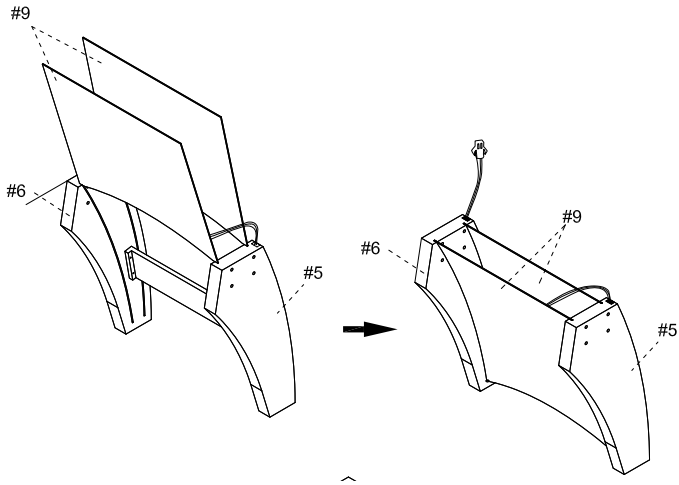

Paso 6

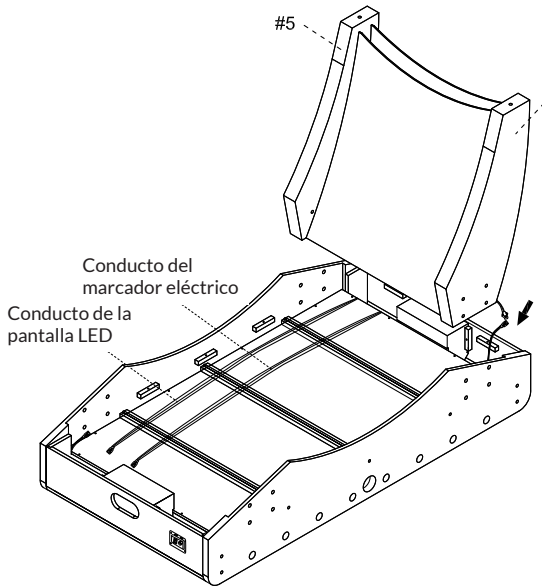

Paso 7

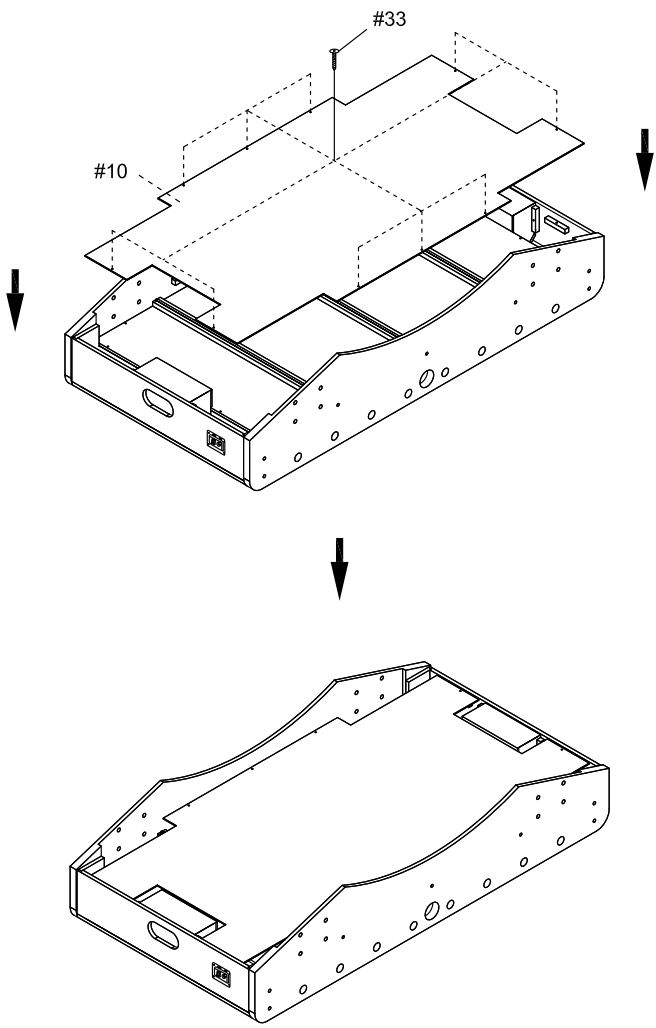

Paso 8

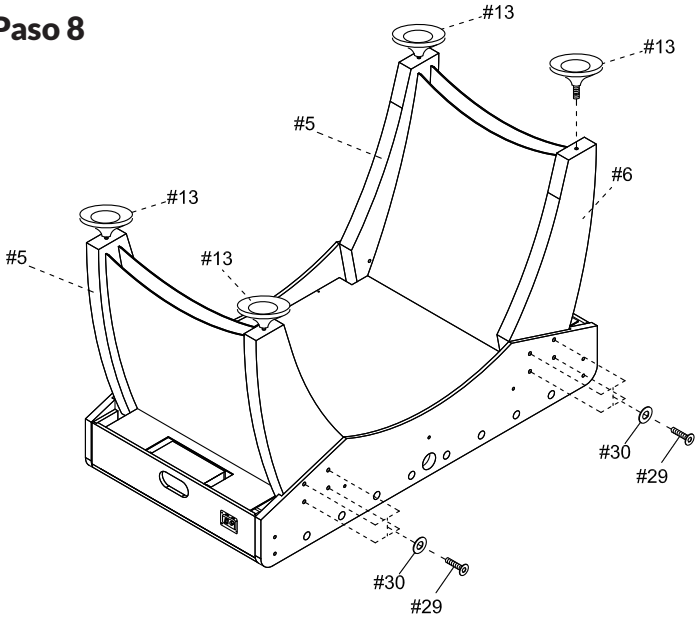

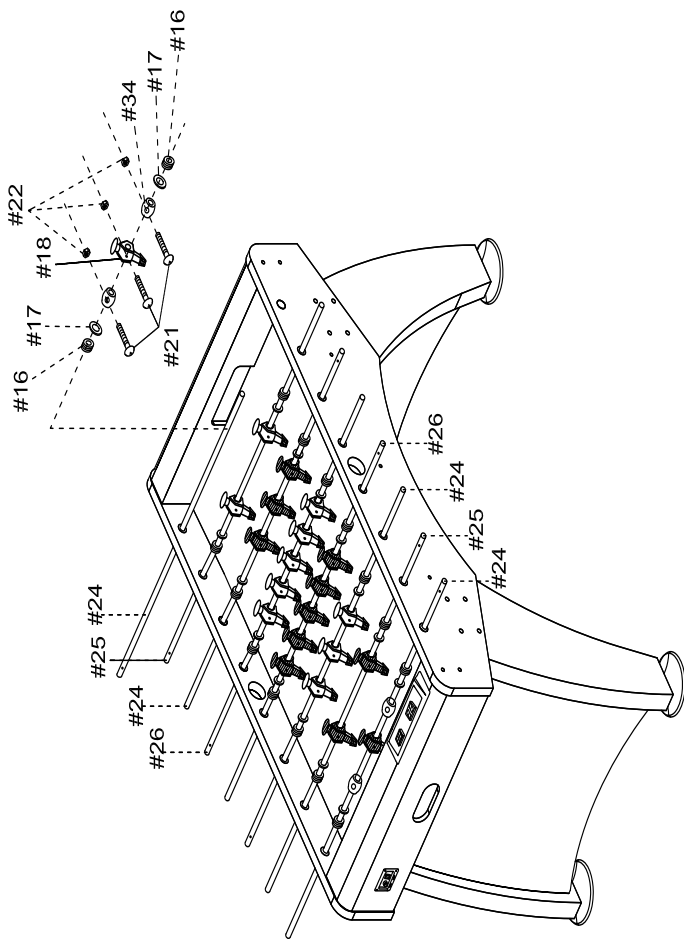

Paso 9

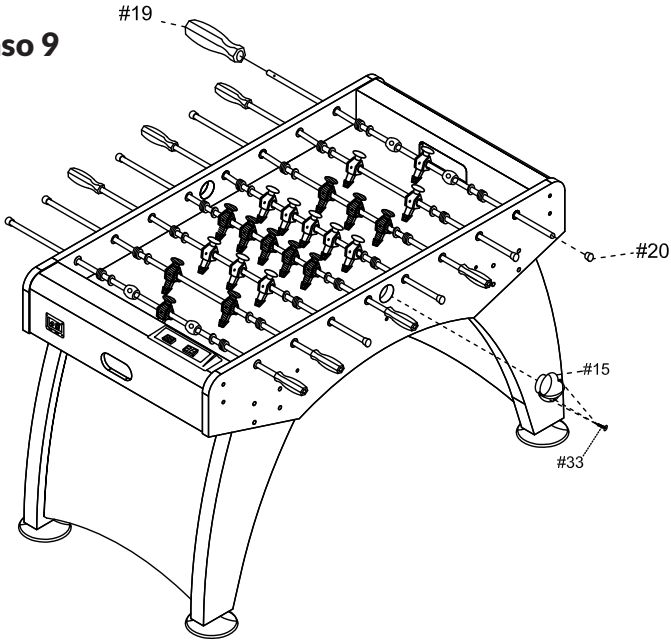

Paso 10

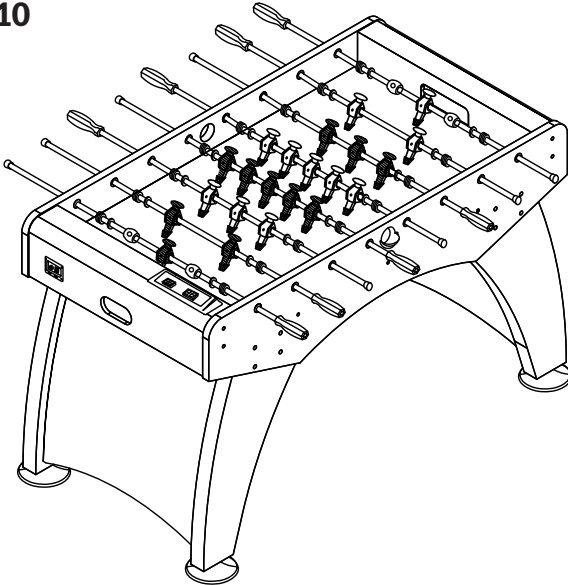

FUNCIÓN DE LAS LUCES LED Y NÚMEROS ELECTRÓNICOS

Conecte el enchufe del aparato a la toma de corriente de su habitación. Todas las luces led se iluminan y el marcador electrónico está listo para funcionar.

Pulse el botón ON en el marcador electrónico. La pantalla del marcador se ilumina y está lista para funcionar. El marcador puede contar para 2 jugadores o equipos de 0 a 99 goles. Cada vez que uno de los jugadores o el equipo marca un gol, el marcador añade el gol al recuento, emite un sonido y un espectáculo de luces led. Puede empezar a jugar en cualquier momento.

Pulse el botón RESET si desea detener el partido actual y empezar uno nuevo. Los dos marcadores volverán a cero. Puede hacerlo en cualquier momento.

Pulse el botón OFF en el marcador electrónico para detener el partido. La pantalla del marcador se apagará. Desconecte el enchufe de la toma de corriente y guarde el balón en un lugar seguro,

ESQUEMA DE CIRCUITOS

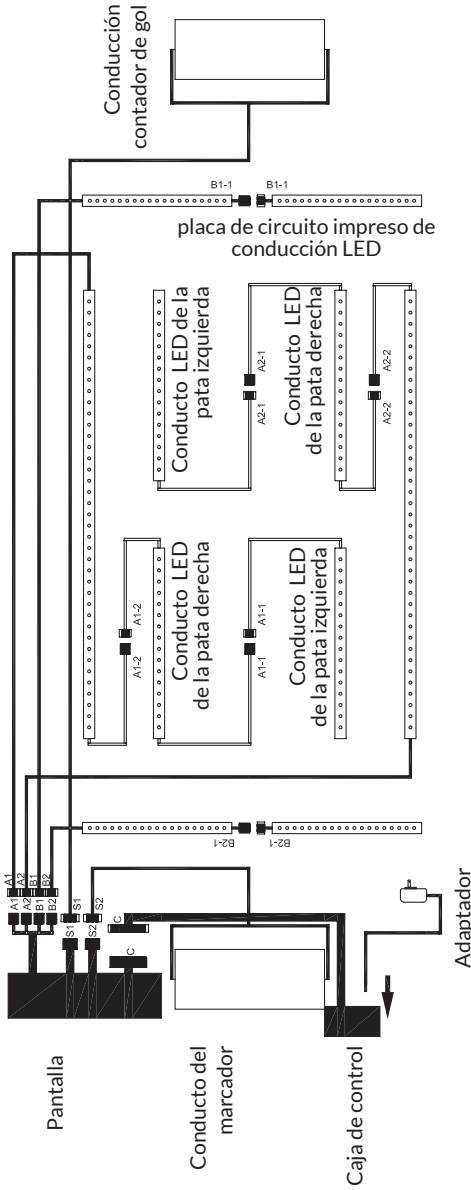

LIMPIEZA Y CUIDADO

Para que el nuevo fútbolín conserve perfectamente sus características de juego, es necesario cuidarlo adecuadamente. El cuidado del fútbolín se limita principalmente a lubricar las barras y a limpiar el campo de juego.

Limpieza de las barras de jugadores

Para limpiar las barras, aplique un poco de limpiacristales a un paño suave y limpie las barras con él. También debe lubricar las barras de vez en cuando para que tengan un movimiento suave.

Lubricación de las barras

El aceite de silicona puro es un buen lubricante. No aplique más de una o dos gotas a cada barra. Distribuya estas gotas por la barra y los cojinetes. Si aplica demasiado aceite de silicona, este puede gotear y la superficie de juego, así como la bola podrían volverse grasosos.

Limpieza de la superficie de juego

No utilice detergentes o limpiadores agresivos que no se puedan eliminar por completo. Se aconseja limpiar la mesa solo con agua.

Si la superficie de juego presenta residuos aceitosos, utilice un limpiacristales sin aditivos especiales para eliminarlos.

RETIRADA DEL APARATO

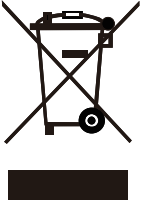

Si el aparato lleva adherida la ilustración de la izquierda (el contenedor de basura tachado), entonces rige la directiva europea 2012/19/UE. Este producto no debe arrojarse a un contenedor de basura común. Infórmese sobre las leyes territoriales que regulan la recogida separada de aparatos eléctricos y electrónicos. Respete las leyes territoriales y no arroje aparatos viejos al cubo de la basura doméstica. Una retirada de aparatos conforme a las leyes contribuye a proteger el medio ambiente y a las personas a su alrededor frente a posibles consecuencias perjudiciales para la salud. El reciclaje ayuda a reducir el consumo de materias primas.

DECLARACIÓN DE CONFORMIDAD

Fabricante:

Chal-Tec GmbH, Wallstraße 16, 10179 Berlin,
Alemania.



Este producto cumple con las siguientes directivas europeas:

2011/65/UE (refundición RoHS)

2014/30/UE (EMC)

2014/35/UE (baja tensión)

