



blumfeldt

## London Grey

Paketpostkasten

Parcel Post Box

Buzón para paquetería

Boîte postale de paquets

Cassetta della posta per pacchi

10035576



**Sehr geehrter Kunde,**

wir gratulieren Ihnen zum Erwerb Ihres Gerätes. Lesen Sie die folgenden Hinweise sorgfältig durch und befolgen Sie diese, um möglichen Schäden vorzubeugen. Für Schäden, die durch Missachtung der Hinweise und unsachgemäßen Gebrauch entstehen, übernehmen wir keine Haftung. Scannen Sie den folgenden QR-Code, um Zugriff auf die aktuellste Bedienungsanleitung und weitere Informationen rund um das Produkt zu erhalten:



---

**HERSTELLER**



---

Chal-Tec GmbH, Wallstraße 16, 10179 Berlin, Deutschland.

---

**ZUBEHÖR**

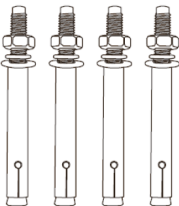
---

		
<p>Abdeckung</p>	<p>Anker (4x)</p>	<p>Schlüssel (2x)</p>

# INSTALLATION

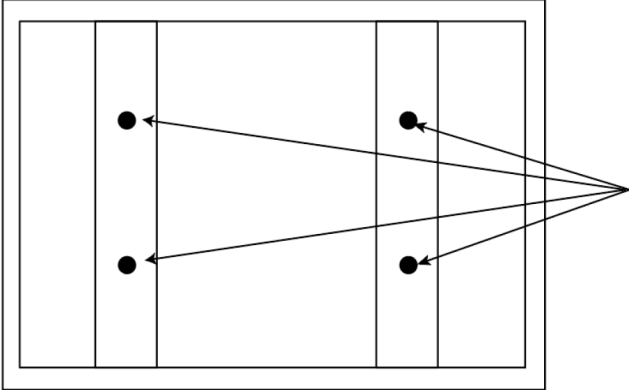
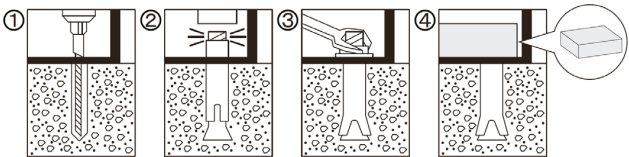
1	<p>Es befinden sich 4 Löcher an der Unterseite der Paketbox. Bevor Sie mit der Installation beginnen, messen sich den Abstand zwischen den Löchern ab mit einem Maßband ab.</p> 
2	<p>Verwenden Sie die abgemessenen Abstände, wenn Sie die Löcher (Tiefe: 85 mm, Durchmesser: 12 mm) in den Untergrund bohren.</p>
3	<p>Richten Sie die Löcher am Boden der Paketbox an den gebohrten Löchern aus und fixieren Sie die Paketbox mit den Anker im Untergrund.</p>
4	<p>Benutzen Sie zum Festziehen der Anker einen Schraubschlüssel.</p>
5	<p>Setzen Sie zum Schluss die Abdeckung auf die Anker.</p> 

**Dear Customer,**

Congratulations on purchasing this device. Please read the following instructions carefully and follow them to prevent possible damages. We assume no liability for damage caused by disregard of the instructions and improper use. Scan the QR code to get access to the latest user manual and more product information.



---

**PRODUCER**



---

Chal-Tec GmbH, Wallstraße 16, 10179 Berlin, Germany.

---

**ACCESSORY**

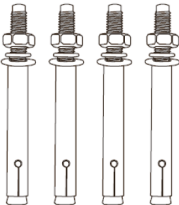
---

		
<p>Cover</p>	<p>Anchor (4x)</p>	<p>Keys (2x)</p>

## INSTALLATION

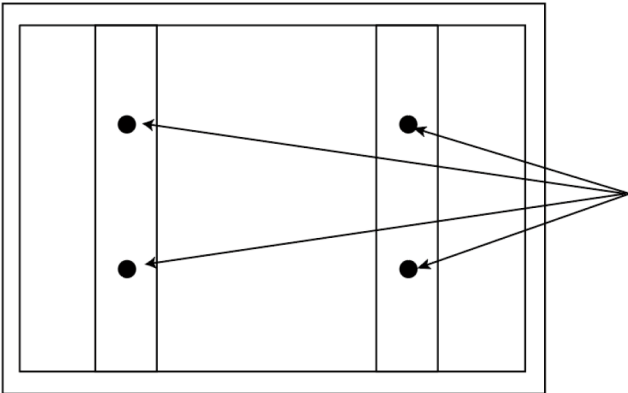
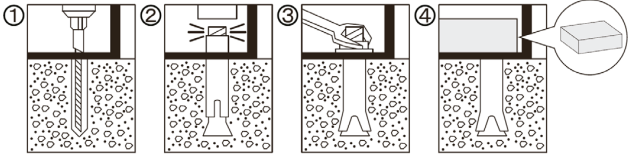
1	<p>There are 4 fixed holes on the bottom of parcel box. Before you start to install, please measure the actual holes distance on the box with measuring tool.</p>  <p>The diagram shows a rectangular parcel box with four vertical lines representing internal dividers. On the bottom edge, there are four black dots representing holes. Two lines from a single point on the right side of the box point to the two holes on the left, and two lines from a single point on the right side of the box point to the two holes on the right, indicating measurement points.</p>
2	<p>Use the measured distances when drilling the holes (depth: 85 mm, diameter: 12 mm) into the substrate.</p>
3	<p>Align the holes at the bottom of the parcel box with the drilled holes and fix the parcel box to the substrate with the anchors.</p>
4	<p>Use a wrench to tighten the anchors.</p>
5	<p>Finally, place the cover on the anchors.</p>  <p>The diagram consists of four numbered steps: 1. A drill bit is shown drilling a hole into a substrate. 2. An anchor is inserted into the hole. 3. A wrench is used to tighten the anchor. 4. A cover is placed over the anchor. A callout box shows a perspective view of the cover.</p>

**Estimado cliente,**

Le felicitamos por la adquisición de este producto. Lea atentamente las siguientes instrucciones y sígalas para evitar posibles daños. No asumimos ninguna responsabilidad por los daños causados por el incumplimiento de las instrucciones y el uso inadecuado. Escanee el siguiente código QR para obtener acceso a la última guía del usuario y más información sobre el producto.



---

**FABRICANTE**



---

Chal-Tec GmbH, Wallstraße 16, 10179 Berlín, Alemania.

---

**ACCESORIOS**

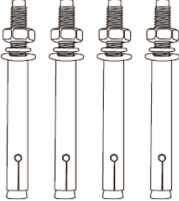
---

		
Cubierta	Anclaje (4x)	Llaves (2x)

# INSTALACIÓN

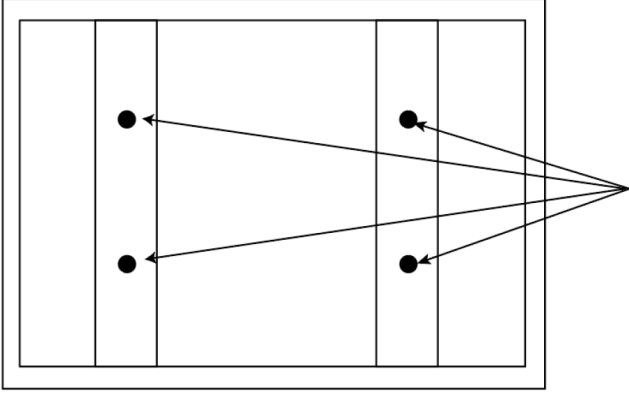
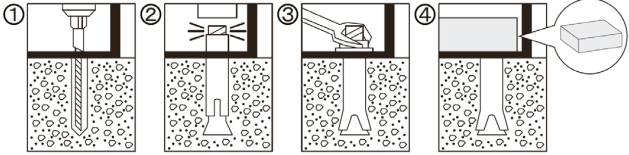
1	<p>Hay 4 orificios en la parte inferior del buzón. Antes de comenzar con la instalación, mida la distancia entre los orificios con una cinta métrica.</p> 
2	<p>Utilice las distancias medidas para perforar orificios en la superficie de apoyo (profundidad: 85 mm, diámetro: 12 mm).</p>
3	<p>Alinee los orificios del fondo del buzón con los perforados en la superficie de apoyo y fije el buzón al suelo con los anclajes.</p>
4	<p>Utilice una llave para apretar los anclajes.</p>
5	<p>Por último, coloque la cubierta sobre los anclajes.</p> 

**Chère cliente, cher client,**

Toutes nos félicitations pour l'acquisition de ce nouvel appareil. Veuillez lire attentivement et respecter les instructions de ce mode d'emploi afin d'éviter d'éventuels dommages. Nous ne saurions être tenus pour responsables des dommages dus au non-respect des consignes et à la mauvaise utilisation de l'appareil. Scannez le QR-Code pour obtenir la dernière version du mode d'emploi et des informations supplémentaires concernant le produit.



---

**FABRICANT**



---

Chal-Tec GmbH, Wallstraße 16, 10179 Berlin, Allemagne.

---

**ACCESSOIRES**

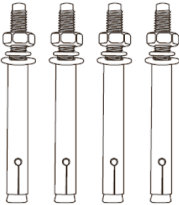
---

		
Couvercle	Ancre (4x)	Clé (2x)

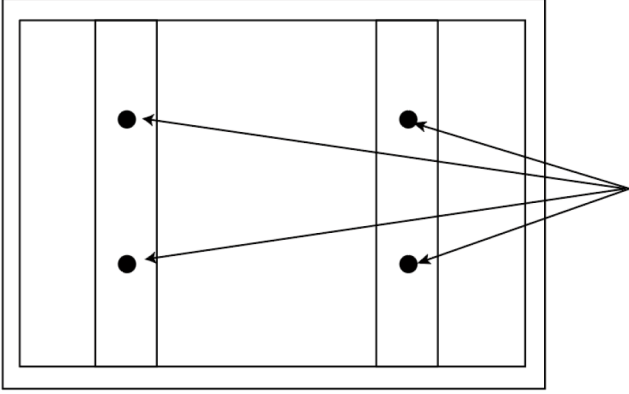
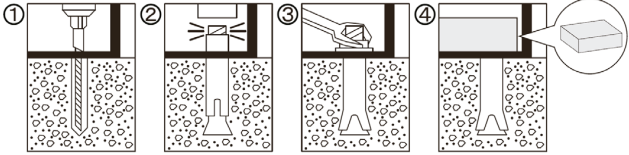

# INSTALLATION

1	<p>Le dessous de la boîte à paquets comprend 4 trous. Avant de commencer l'installation, mesurer la distance entre les trous à l'aide d'un mètre à ruban.</p> 
2	<p>Utiliser les distances mesurées pour percer les trous dans le support (profondeur : 85 mm, diamètre : 12 mm).</p>
3	<p>Aligner les trous du fond de la boîte à paquets avec les trous percés et fixer la boîte à paquets au support à l'aide des ancres.</p>
4	<p>Utiliser une clé anglaise pour serrer les ancres.</p>
5	<p>Pour finir, placer le couvercle sur les ancres.</p> 

**Gentile cliente,**

La ringraziamo per aver acquistato il dispositivo. La preghiamo di leggere attentamente le seguenti istruzioni per l'uso e di seguirle per evitare possibili danni. Non ci assumiamo alcuna responsabilità per danni scaturiti da una mancata osservazione delle avvertenze di sicurezza e da un uso improprio del dispositivo. Scansionare il codice QR seguente, per accedere al manuale d'uso più attuale e per ricevere informazioni sul prodotto.



---

**PRODUTTORE**



---

Chal-Tec GmbH, Wallstraße 16, 10179 Berlino, Germania.

---

**ACCESSORI**

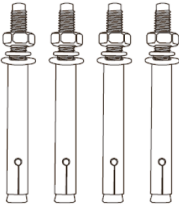
---

		
Coperchio	Elemento di fissaggio (4x)	Chiave (2x)

## INSTALLAZIONE

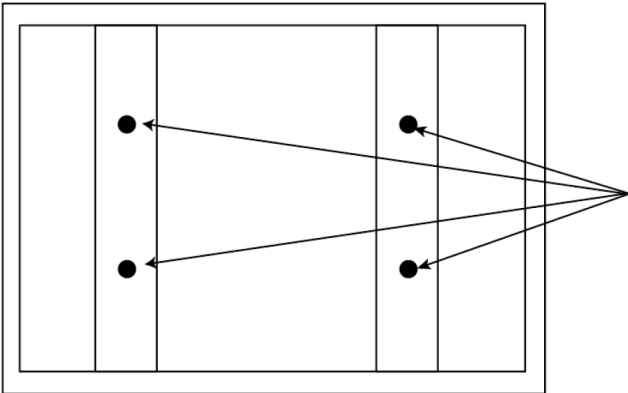
1	<p>Nella parte inferiore della cassetta pacchi ci sono 4 fori. Prima di installare la cassetta, misurare la distanza tra i fori servendosi di un metro.</p> 
2	<p>Fare riferimento alle distanze misurate per eseguire i fori nel pavimento (profondità: 85 mm, diametro: 12 mm).</p>
3	<p>Allineare i fori sulla parte inferiore della cassetta ai fori eseguiti e fissare la cassetta al pavimento utilizzando gli elementi di fissaggio.</p>
4	<p>Utilizzare un cacciavite per serrare gli elementi di fissaggio.</p>
5	<p>Infine mettere il coperchio per coprire gli elementi di fissaggio.</p> 