



blumfeldt

Hexawood

Holzlager

Wood Storage

Abri pour bois de cheminée

Depósito de madera

Portalegna

10035764 10035765



Sehr geehrter Kunde,

wir gratulieren Ihnen zum Erwerb Ihres Gerätes. Lesen Sie die folgenden Hinweise sorgfältig durch und befolgen Sie diese, um möglichen Schäden vorzubeugen. Für Schäden, die durch Missachtung der Hinweise und unsachgemäßen Gebrauch entstehen, übernehmen wir keine Haftung. Scannen Sie den folgenden QR-Code, um Zugriff auf die aktuellste Bedienungsanleitung und weitere Informationen rund um das Produkt zu erhalten:

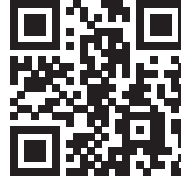
**Dear Customer,**

Congratulations on purchasing this device. Please read the following instructions carefully and follow them to prevent possible damages. We assume no liability for damage caused by disregard of the instructions and improper use. Scan the QR code to get access to the latest user manual and more product information.









WICHTIGE HINWEISE / IMPORTANT NOTES

<p>Sicherheit</p> <ul style="list-style-type: none"> Überprüfen Sie nach dem Aufstellen des Holzlagers, ob es stabil steht. 	<p>Safety</p> <ul style="list-style-type: none"> After setting up the wood storage, check that it is stable.
<p>Reinigung und Pflege</p> <ul style="list-style-type: none"> Wischen Sie die Oberfläche mit einem feuchten Lappen ab. Verwenden Sie keine Scheuermittel und scharfen Reiniger. 	<p>Cleaning and Care</p> <ul style="list-style-type: none"> Wipe the surface with a damp cloth. Do not use scouring agents or sharp cleaners.

HERSTELLER / PRODUCER

Chal-Tec GmbH, Wallstraße 16, 10179 Berlin, Deutschland (Germany)

LIEFERUMFANG / SCOPE OF DELIVERY

A		B	
			
1x		1x	
Gehäuse 1	Body 1	Gehäuse 2	Body 2
C		D	
			
1x		5x	
Kippsicherung	Anti-tilt device	Mutter	Nut
E		F	
			
5x		1x	
Schraube	Screw	Dehnschraube	Expansion screw

ZUSAMMENBAU / ASSEMBLY

1

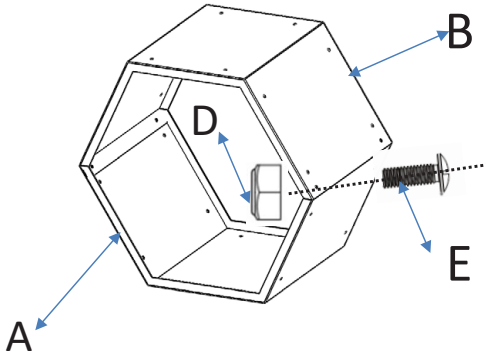

Verbinden Sie das Gehäuse 1 (A) und das Gehäuse 2 (B) mit Schrauben (E) und Muttern (D).

Connect the body 1 (A) and the body 2 (B) with screws (E) and nuts (D).

2

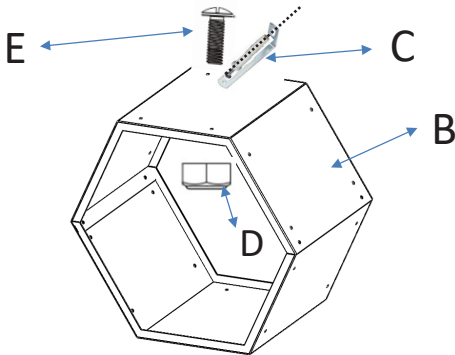

Befestigen Sie die Kippsicherung (C) auf der einen Seite mit Schrauben (E) und Muttern (D) am Holzlager und auf der anderen Seite mit der Dehnschraube (F) an der Wand.

Fix the anti-tilt device (C) on one side with screws (E) and nuts (D) to the wood storage and on the other side with the expansion screw (F) to the wall.

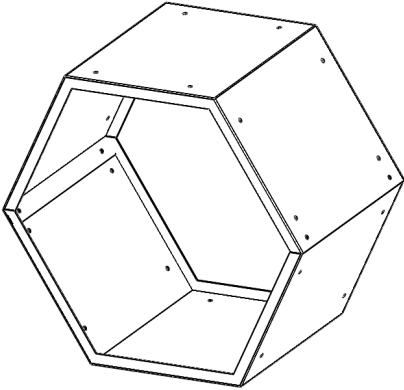
3

Das Holzlager ist nun fertig zusammengebaut und einsatzbereit.
The wood storage is now fully assembled and ready for use.

Chère cliente, cher client,

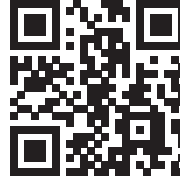
Toutes nos félicitations pour l'acquisition de ce nouvel appareil. Veuillez lire attentivement et respecter les instructions de ce mode d'emploi afin d'éviter d'éventuels dommages. Nous ne saurions être tenus pour responsables des dommages dus au non-respect des consignes et à la mauvaise utilisation de l'appareil. Scannez le QR-Code pour obtenir la dernière version du mode d'emploi et des informations supplémentaires concernant le produit.:

**Estimado cliente,**

Le felicitamos por la adquisición de este producto. Lea atentamente las siguientes instrucciones y sígalas para evitar posibles daños. No asumimos ninguna responsabilidad por los daños causados por el incumplimiento de las instrucciones y el uso inadecuado. Escanee el siguiente código QR para obtener acceso a la última guía del usuario y más información sobre el producto.



NOTES IMPORTANTES / NOTAS IMPORTANTES



<p>Sécurité</p> <ul style="list-style-type: none"> • Après avoir installé l'abri pour bois de cheminée, vérifiez qu'il est stable. 	<p>Seguridad</p> <ul style="list-style-type: none"> • Después de montar el depósito de madera, compruebe que es estable.
<p>Nettoyage et entretien</p> <ul style="list-style-type: none"> • Nettoyez la surface avec un chiffon humide. N'utilisez pas de produits abrasifs ou de nettoyeurs agressifs. 	<p>Limpieza y cuidado</p> <ul style="list-style-type: none"> • Limpie la superficie con un paño húmedo. • No utilice limpiadores abrasivos o agresivos.

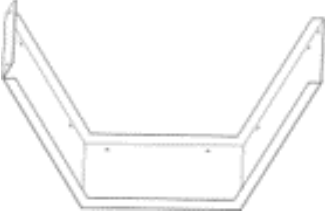
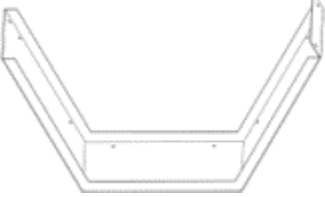

FABRICANT / FABRICANTE

Chal-Tec GmbH, Wallstraße 16, 10179 Berlin, Allemagne
 Chal-Tec GmbH, Wallstraße 16, 10179 Berlin, Alemania

CONTENU DE L'EMBALLAGE / CONTENIDO DE LA ENTREGA

A		B	
			
1x		1x	
Structure 1	Carcasa 1	Structure 2	Carcasa 2

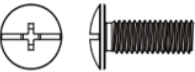
C		D	
			
1x		5x	
Anti basculement	Antivuelco	Écrou	Tuerca

E		F	
			
5x		1x	
Vis	Tornillo	Vis d'expansion	Tornillo expansor

ASSEMBLAGE / MONTAJE

1

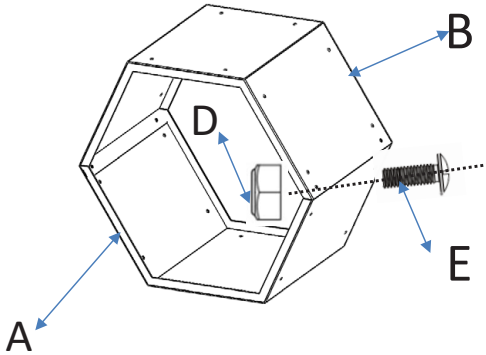

Reliez la structure 1 (A) et la structure 2 (B) avec les vis (E) et les écrous (D).

Conecte la carcasa 1 (A) y la carcasa 2 (B) con tornillos (E) y tuercas (D).

2

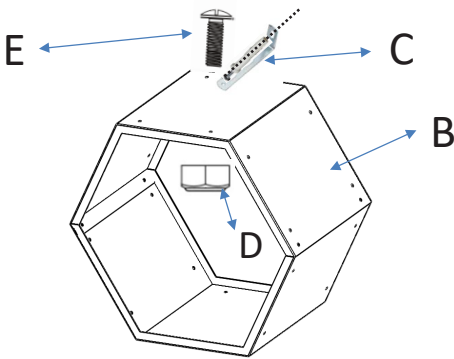

Fixez le dispositif anti-bascule (C) à l'abri pour bois d'un côté avec les vis (E) et les écrous (D) et à la paroi de l'autre côté avec la vis d'expansion (F).

Fije el dispositivo antivuelco (C) por un lado con tornillos (E) y tuercas (D) al almacén de madera y por el otro lado con el tornillo de expansión (F) a la pared.

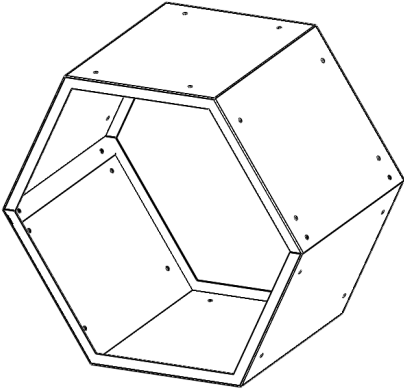
3

<p>L'abri pour bois de cheminée est maintenant entièrement assemblé et prêt à l'emploi.</p>
<p>El depósito de madera está ahora completamente montado y listo para su uso.</p>

Gentile cliente,

La ringraziamo per aver acquistato il dispositivo. La preghiamo di leggere attentamente le seguenti istruzioni per l'uso e di seguirle per evitare possibili danni. Non ci assumiamo alcuna responsabilità per danni scaturiti da una mancata osservazione delle avvertenze di sicurezza e da un uso improprio del dispositivo. Scansionare il codice QR seguente, per accedere al manuale d'uso più attuale e per ricevere informazioni sul prodotto.



NOTE IMPORTANTI

Sicurezza

- Dopo aver installato il portalegna, controllate che sia stabile.





Pulizia e manutenzione

- Pulire la superficie con un panno umido.
Non usare detergenti abrasivi o aggressivi.

PRODUTTORE

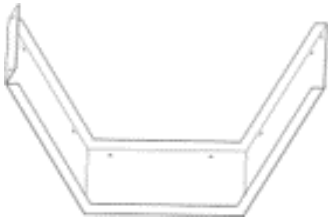
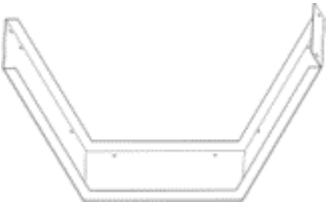
Chal-Tec GmbH, Wallstraße 16, 10179 Berlino, Germania

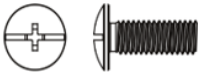
VOLUME DI CONSEGNA

A	B
 <p data-bbox="471 472 496 491">1x</p>	 <p data-bbox="833 472 857 491">1x</p>
Alloggiamento 1	Alloggiamento 2
C	D
 <p data-bbox="471 831 496 850">1x</p>	 <p data-bbox="833 831 857 850">5x</p>
Sistema antiribaltamento	Dadi
E	F
 <p data-bbox="471 1240 496 1259">5x</p>	 <p data-bbox="833 1240 857 1259">1x</p>
Viti	Vite a espansione

ASSEMBLAGGIO

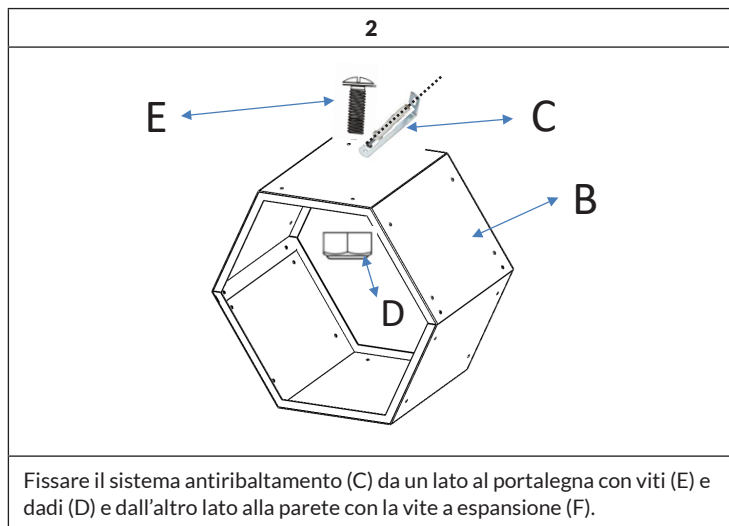
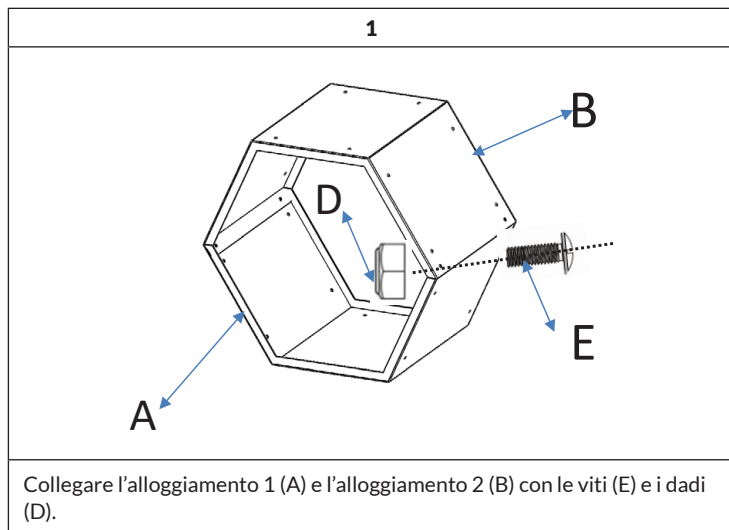

3

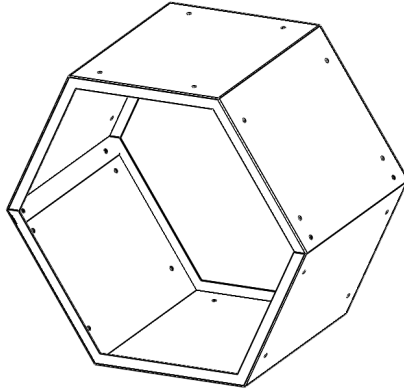

Il portalegna è ora completamente montato e pronto all'uso.

