



blumfeldt



Pantheon Cortina

Pergola

10033318 10033319 10035883 10035884 10035895 10035896

Sehr geehrter Kunde,

wir gratulieren Ihnen zum Erwerb Ihres Gerätes. Lesen Sie die folgenden Hinweise sorgfältig durch und befolgen Sie diese, um möglichen Schäden vorzubeugen. Für Schäden, die durch Missachtung der Hinweise und unsachgemäßen Gebrauch entstehen, übernehmen wir keine Haftung. Scannen Sie den folgenden QR-Code, um Zugriff auf die aktuellste Bedienungsanleitung und weitere Informationen rund um das Produkt zu erhalten:

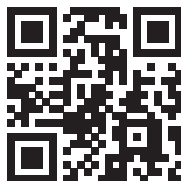
**Dear Customer,**

Congratulations on purchasing this device. Please read the following instructions carefully and follow them to prevent possible damages. We assume no liability for damage caused by disregard of the instructions and improper use. Scan the QR code to get access to the latest user manual and more product information.

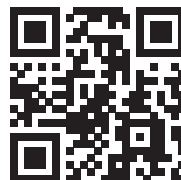
**Estimado cliente,**

Le felicitamos por la adquisición de este producto. Lea atentamente las siguientes instrucciones y sígalas para evitar posibles daños. No asumimos ninguna responsabilidad por los daños causados por el incumplimiento de las instrucciones y el uso inadecuado. Escanee el siguiente código QR para obtener acceso a la última guía del usuario y más información sobre el producto.

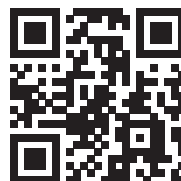
**Chère cliente, cher client,**

Toutes nos félicitations pour l'acquisition de ce nouvel appareil. Veuillez lire attentivement et respecter les instructions de ce mode d'emploi afin d'éviter d'éventuels dommages. Nous ne saurions être tenus pour responsables des dommages dus au non-respect des consignes et à la mauvaise utilisation de l'appareil. Scannez le QR-Code pour obtenir la dernière version du mode d'emploi et des informations supplémentaires concernant le produit.

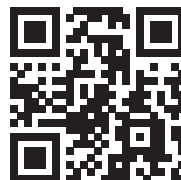





































**Gentile cliente,**

La ringraziamo per aver acquistato il dispositivo. La preghiamo di leggere attentamente le seguenti istruzioni per l'uso e di seguirle per evitare possibili danni. Non ci assumiamo alcuna responsabilità per danni scaturiti da una mancata osservazione delle avvertenze di sicurezza e da un uso improprio del dispositivo. Scansionare il codice QR seguente, per accedere al manuale d'uso più attuale e per ricevere informazioni sul prodotto.



LIEFERUMFANG

Scope of delivery | Volumen de suministro | Contenu de la livraison |
Dotazione di fornitura

A	4				
B	2				
C	2		C2	2	
D	1		E	2	
E2	2		E3	2	
F	2		F2	1	
F3	4		F4	2	
F5	4		F6	2	
F7	2		G	6	
G2	6		H	8	
I	3				
K	4		L	16	
M	4		N	1	
N2	2		N3	8	
P	15				
Q	8		R	8	 Ø6x10
S1	4		S2	4	
T	3	 M6x40	T2	4	 M6x45
U	72	 M6x15			
W	3	 M4x30	X	4	 M6x25
Y	22		Z	1/1	
AA	1				

ZUSAMMENBAU / ASSEMBLY

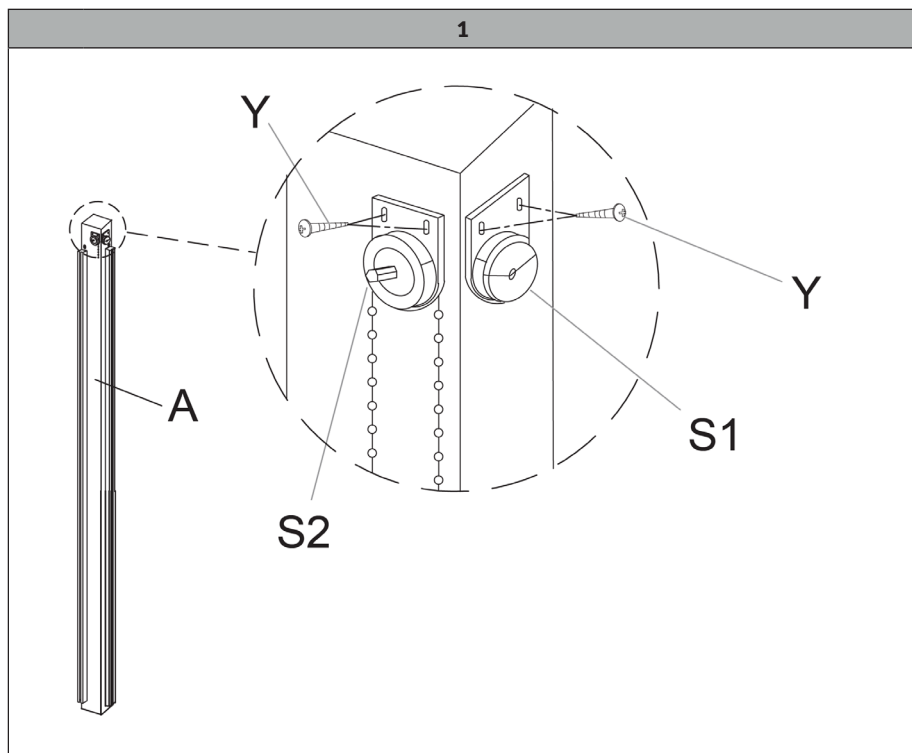

DE	Wiederholen Sie den im Kreis beschriebenen Vorgang an allen 4 Pfosten.
EN	Repeat the process described in the circle on all 4 posts.
ES	Repita el proceso descrito en el círculo en los 4 postes.
FR	Répétez la procédure décrite dans le cercle pour les 4 poteaux.
IT	Ripetere il procedimento descritto nel cerchio su tutti e 4 i pali.

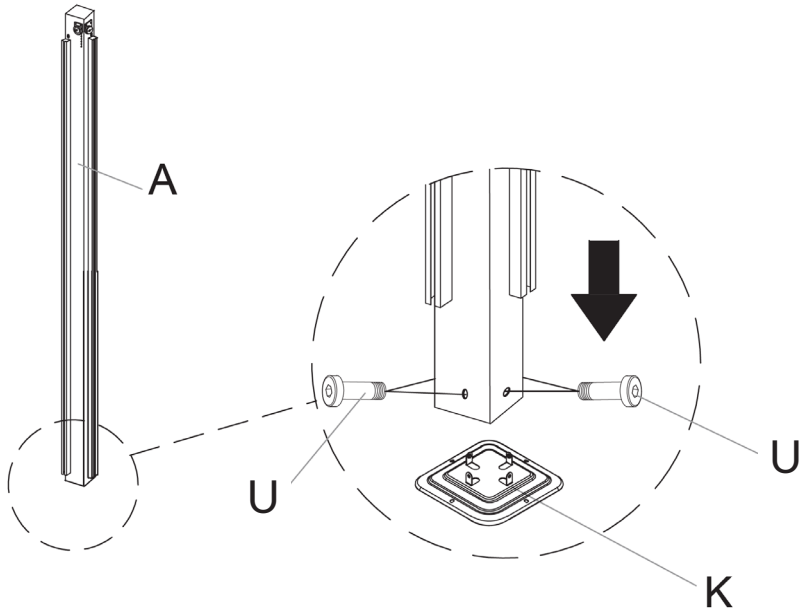

DE	Wiederholen Sie den im Kreis beschriebenen Vorgang an allen 4 Pfosten.
EN	Repeat the process described in the circle on all 4 posts.
ES	Repita el proceso descrito en el círculo en los 4 postes.
FR	Répétez la procédure décrite dans le cercle pour les 4 poteaux.
IT	Ripetere il procedimento descritto nel cerchio su tutti e 4 i pali.

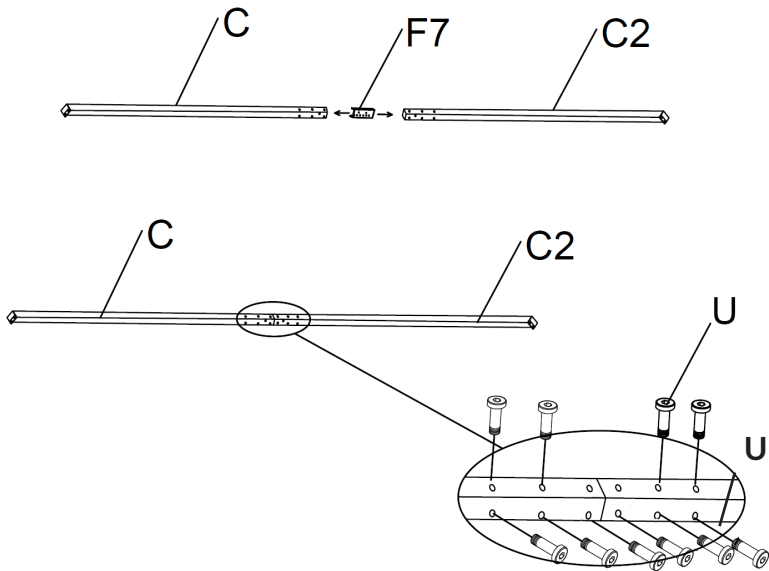

DE	Wiederholen Sie den im Kreis beschriebenen Vorgang zwei Mal.
EN	Repeat the procedure described in the circle twice.
ES	Repite el proceso descrito en el círculo dos veces.
FR	Répétez deux fois la procédure décrite dans le cercle.
IT	Ripetere due volte il procedimento descritto nel cerchio.

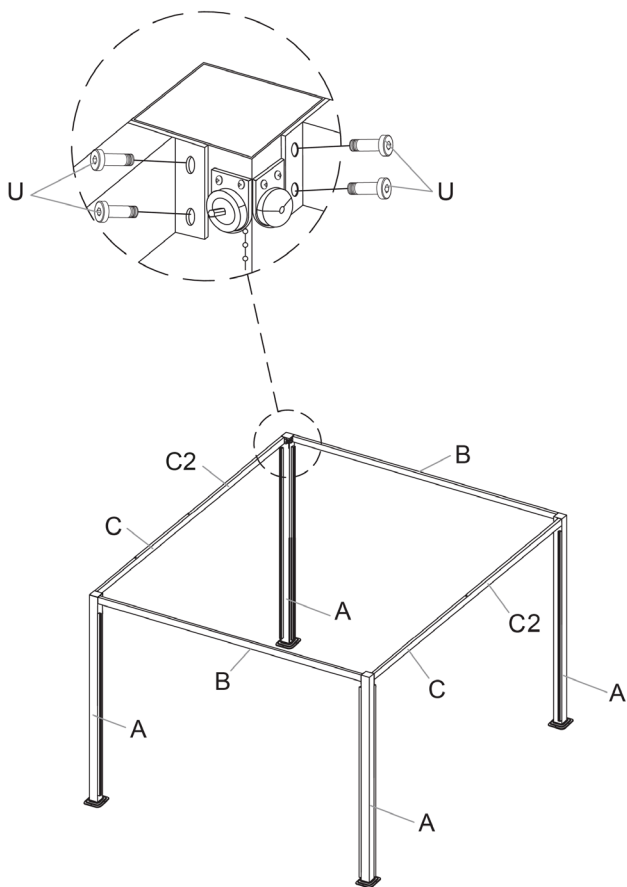

DE	Wiederholen Sie den im Kreis beschriebenen Vorgang an allen 4 Pfosten.
EN	Repeat the process described in the circle on all 4 posts.
ES	Repita el proceso descrito en el círculo en los 4 postes.
FR	Répétez la procédure décrite dans le cercle pour les 4 poteaux.
IT	Ripetere il procedimento descritto nel cerchio su tutti e 4 i pali.

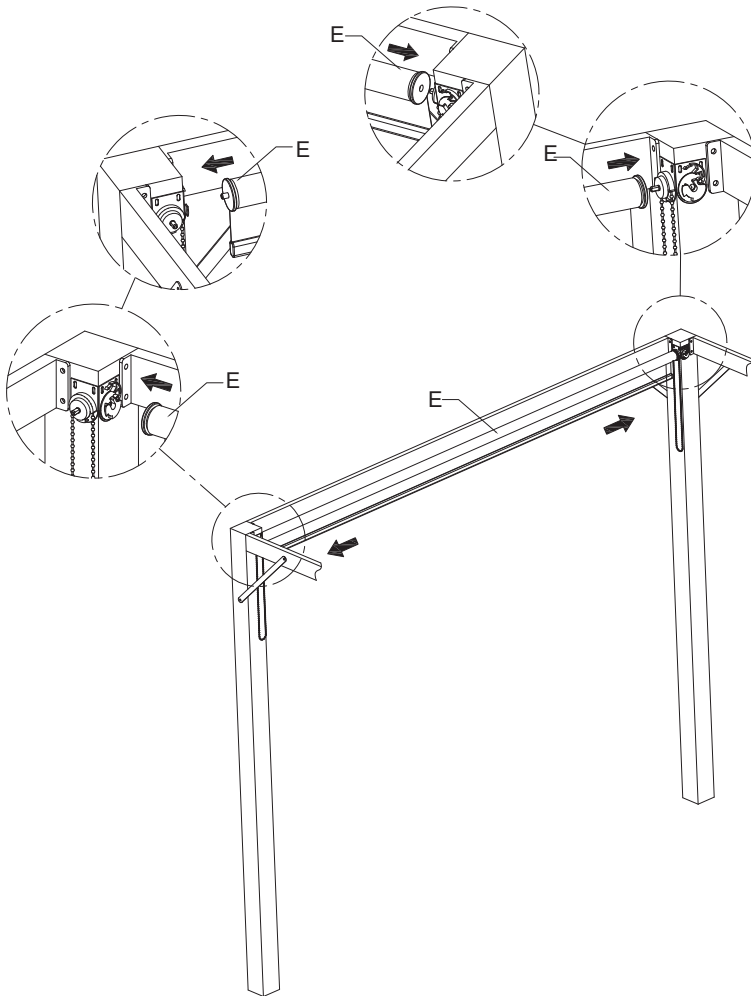

DE Wiederholen Sie den im Kreis beschriebenen Vorgang an allen 4 Pfosten.

EN Repeat the process described in the circle on all 4 posts.

ES Repita el proceso descrito en el círculo en los 4 postes.

FR Répétez la procédure décrite dans le cercle pour les 4 poteaux.

IT Ripetere il procedimento descritto nel cerchio su tutti e 4 i pali.

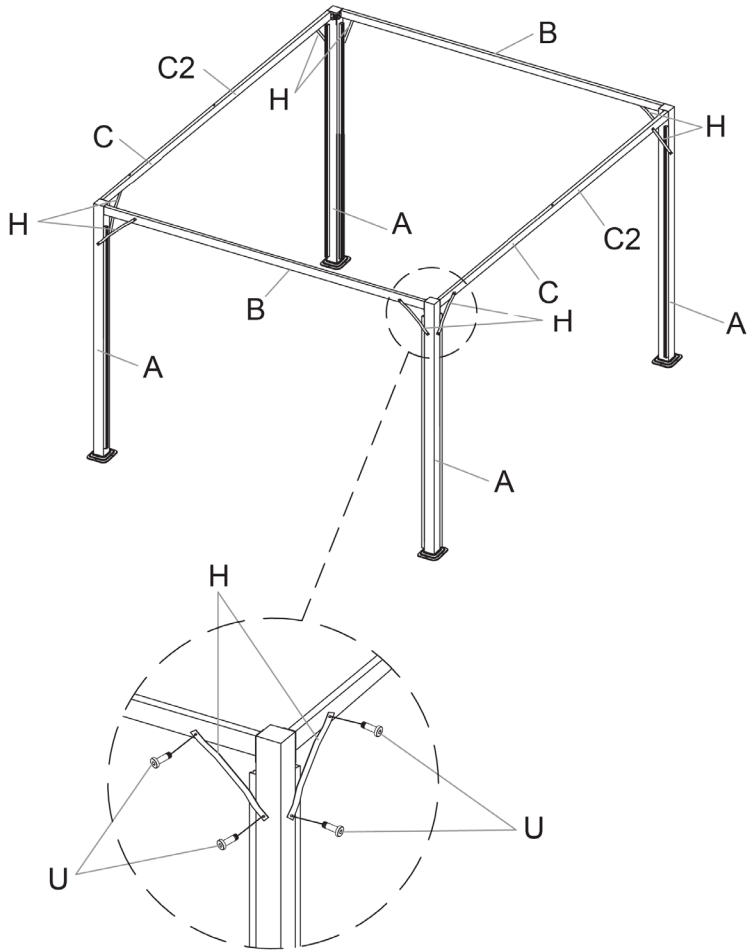

DE	Wiederholen Sie den im Kreis beschriebenen Vorgang an allen 4 Pfosten.
EN	Repeat the process described in the circle on all 4 posts.
ES	Repita el proceso descrito en el círculo en los 4 postes.
FR	Répétez la procédure décrite dans le cercle pour les 4 poteaux.
IT	Ripetere il procedimento descritto nel cerchio su tutti e 4 i pali.

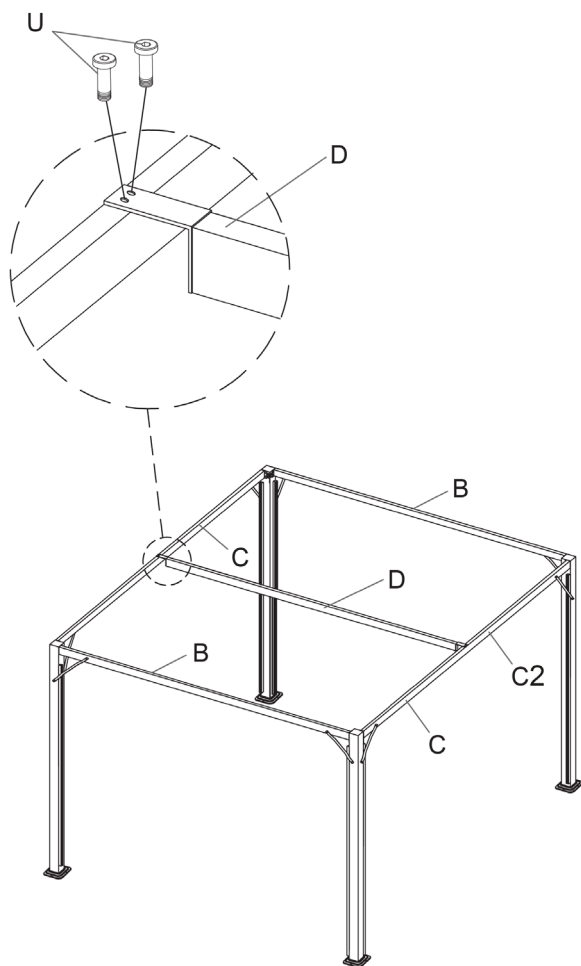

DE	Wiederholen Sie den im Kreis beschriebenen Vorgang am anderen Ende.
EN	Repeat the process described in the circle at the other end.
ES	Repite el proceso descrito en el círculo del otro extremo.
FR	Répétez la procédure décrite dans le cercle à l'autre extrémité.
IT	Ripetere il procedimento descritto nel cerchio all'altra estremità.

8-1



DE	Stecken Sie die beiden Teile N3 in N2.
EN	Insert the two parts N3 into N2.
ES	Inserte las dos piezas N3 en N2.
FR	Insérez les deux pièces N3 dans N2.
IT	Inserire le due parti N3 in N2.

8-2

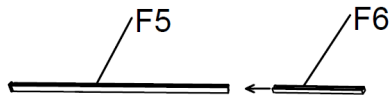

DE	Fügen Sie F5 und F6 zusammen.
EN	Join F5 and F6 together.
ES	Une F5 y F6.
FR	Fusionner F5 et F6.
IT	Unire F5 e F6.

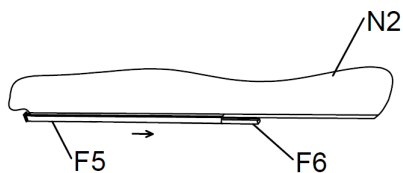
8-3

DE	Schieben Sie die zusammengeführten Teile aus Schritt 8-2 in die zusammengeführten Teile aus Schritt 8-1.
EN	Slide the assembled parts from step 8-2 into the assembled parts from step 8-1.
ES	Introduzca las piezas ensambladas del paso 8-2 en las piezas ensambladas del paso 8-1.
FR	Glisse les pièces assemblées de l'étape 8-2 dans les pièces assemblées de l'étape 8-1.
IT	Spingere le parti assemblate del punto 8-2 nelle parti assemblate del punto 8-1.

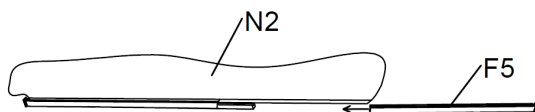
8-4

DE	Schieben Sie ein weiteres Teil F5 in die zusammengeführten Teile aus Schritt 8-1.
EN	Slide another part F5 into the joined parts from step 8-1.
ES	Introduzca otra pieza F5 en las piezas unidas del paso 8-1.
FR	Glisse une autre pièce F5 dans les pièces assemblées de l'étape 8-1.
IT	Spingere un altro pezzo F5 nelle parti unite al punto 8-1.

8-5

DE	Wiederholen Sie die Schritte 8-1 bis 8-4 ein weiteres Mal.
EN	Repeat steps 8-1 to 8-4 once more.
ES	Repita los pasos 8-1 a 8-4 una vez más.
FR	Répétez les étapes 8-1 à 8-4 une autre fois.
IT	Ripetere i passaggi da 8-1 a 8-4 un'altra volta.

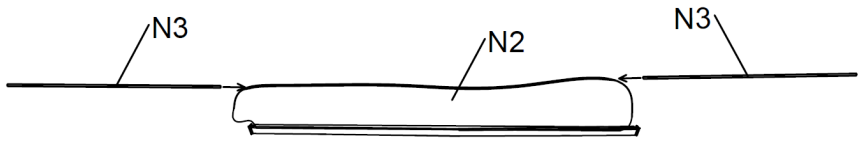
9-1

DE	Befestigen Sie zwei Teile N3 auf N2 (dem Ergebnis aus Schritt 8-4).
EN	Attach two parts N3 to N2 (the result of step 8-4).
ES	Una dos piezas N3 a N2 (el resultado del paso 8-4).
FR	Fixe deux pièces N3 sur N2 (le résultat de l'étape 8-4).
IT	Collegare le due parti N3 a N2 (il risultato del passaggio 8-4).

9-2

DE	Schrauben Sie E3 halb hinein.
EN	Screw E3 halfway in.
ES	Que le den al E3 a medias.
FR	Vissez E3 à moitié.
IT	Fanculo all'E3 a metà strada.

9-3

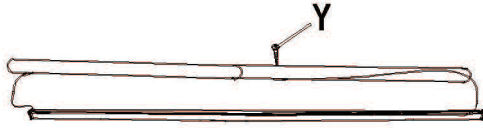

DE Schrauben Sie Y hinein.

EN Screw Y in.

ES Que le den al Y.

FR Vissez Y..

IT Fanculo all' Y.

t

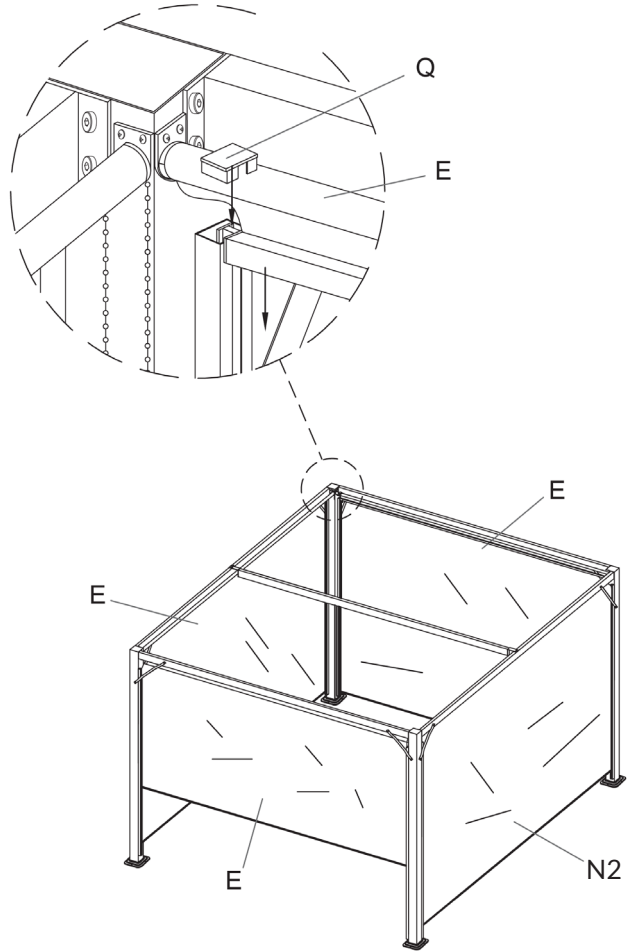

DE	Setzen Sie insgesamt 8 Endkappen ein.
EN	Insert a total of 8 end caps.
ES	Inserte un total de 8 tapas de extremo.
FR	Placez un total de 8 embouts.
IT	Inserire un totale di 8 tappi di chiusura.

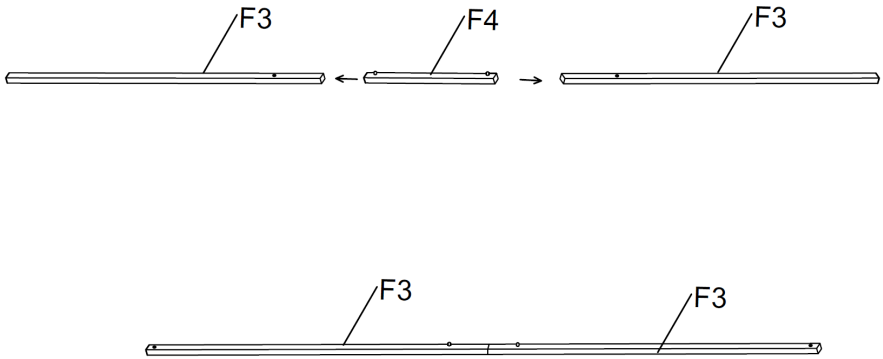

DE	Wiederholen Sie diesen Schritt zwei Mal.
EN	Repeat this step twice.
ES	Repita este paso dos veces.
FR	Répétez cette étape deux fois.
IT	Ripetere questo passaggio due volte.

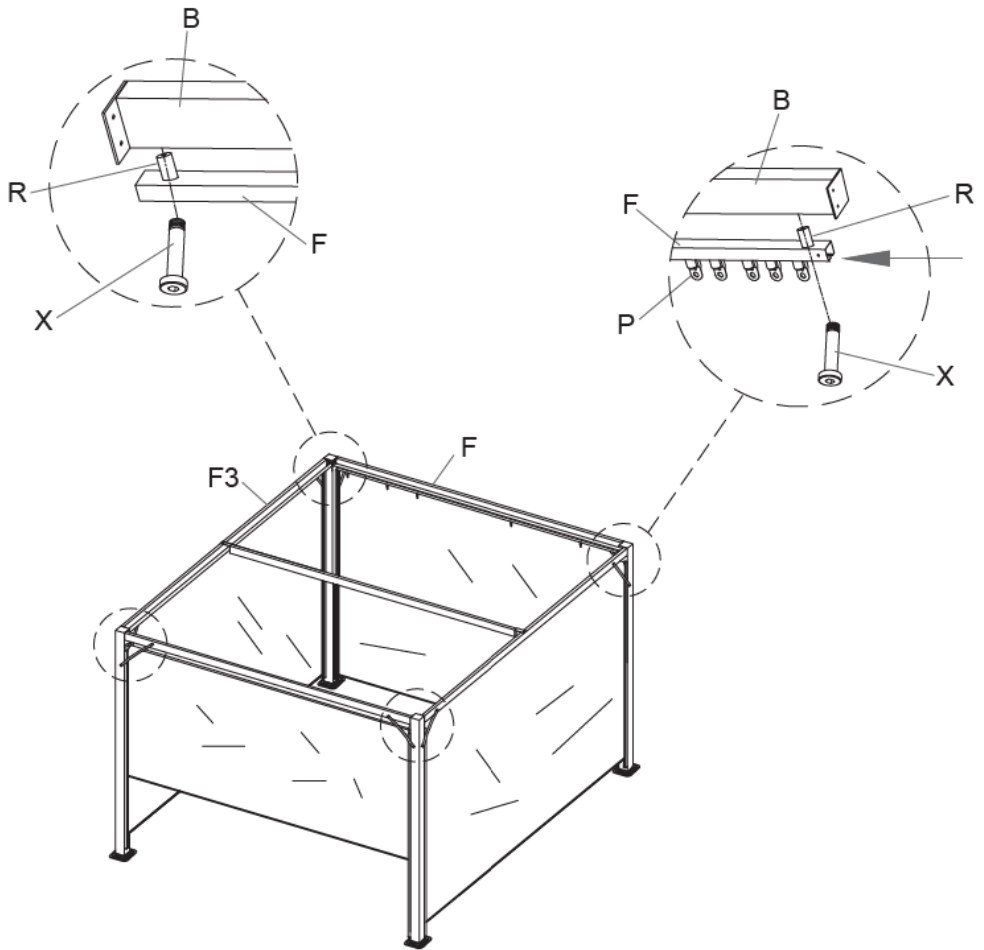

DE Wiederholen Sie den im Kreis beschriebenen Vorgang auf der anderen Seite.

EN Repeat the process described in the circle on the other side.

ES Repita el proceso descrito en el círculo del otro lado.

FR Répétez la procédure décrite dans le cercle de l'autre côté.

IT Ripetere il procedimento descritto nel cerchio sull'altro lato.

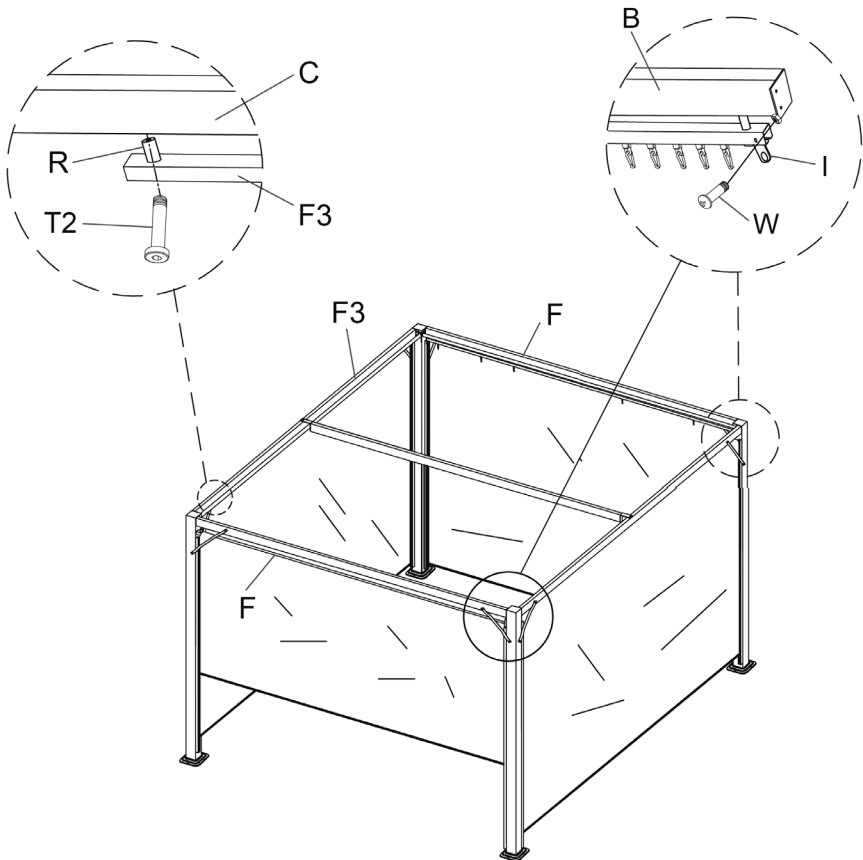

DE	Wiederholen Sie den im linken Kreis beschriebenen Vorgang an allen 4 Querpfosten, den im rechten Kreis beschriebenen Vorgang an beiden Enden.
EN	Repeat the process described in the left circle on all 4 cross posts, and the process described in the right circle on both ends.
ES	Repita el proceso descrito en el círculo de la izquierda en los 4 postes transversales, el proceso descrito en el círculo de la derecha en ambos extremos.
FR	Répétez la procédure décrite dans le cercle de gauche pour les 4 poteaux transversaux, et la procédure décrite dans le cercle de droite pour les deux extrémités.
IT	Ripetere il procedimento descritto nel cerchio di sinistra su tutti e 4 i montanti trasversali, il procedimento descritto nel cerchio di destra su entrambe le estremità.

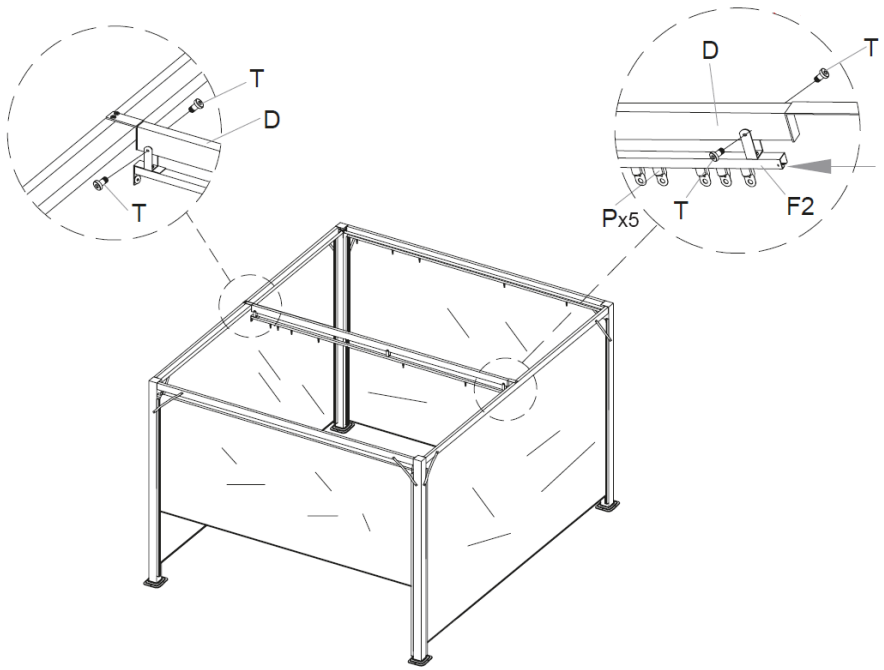

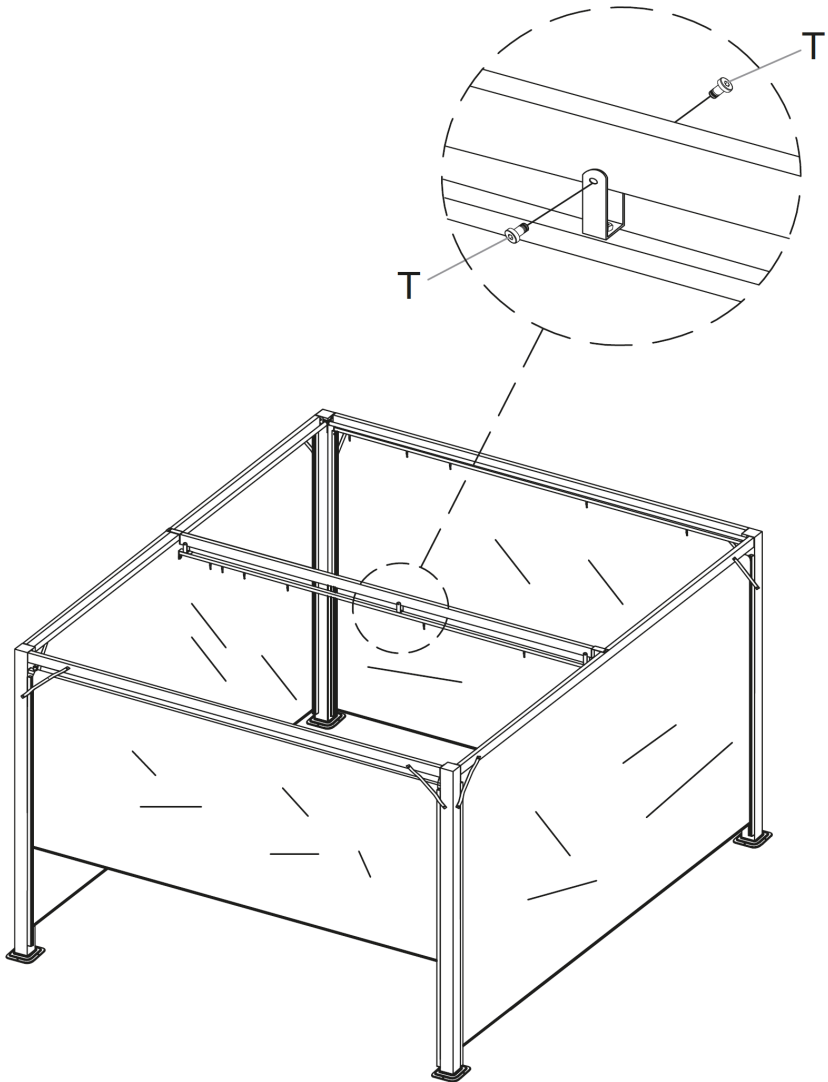

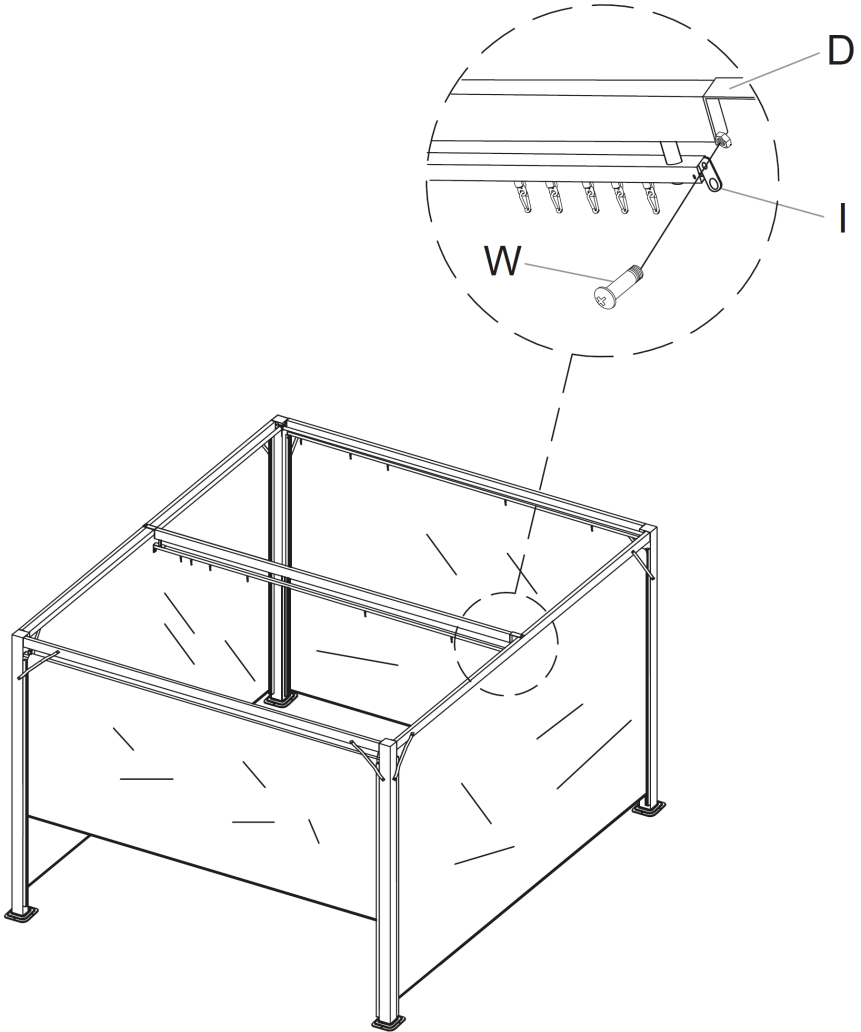

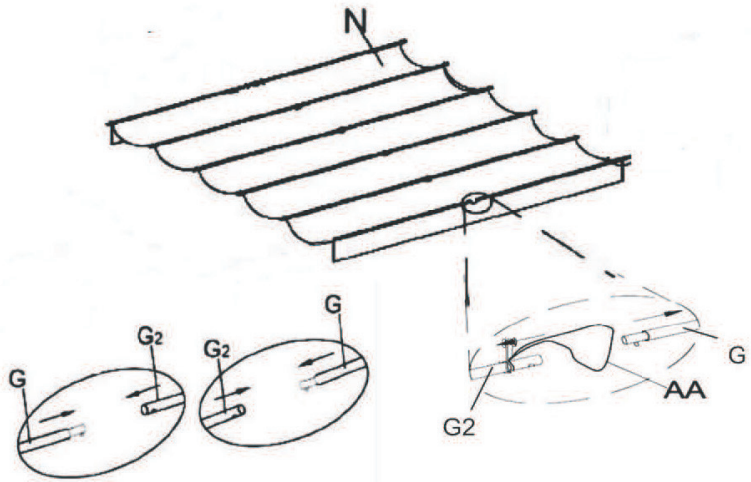

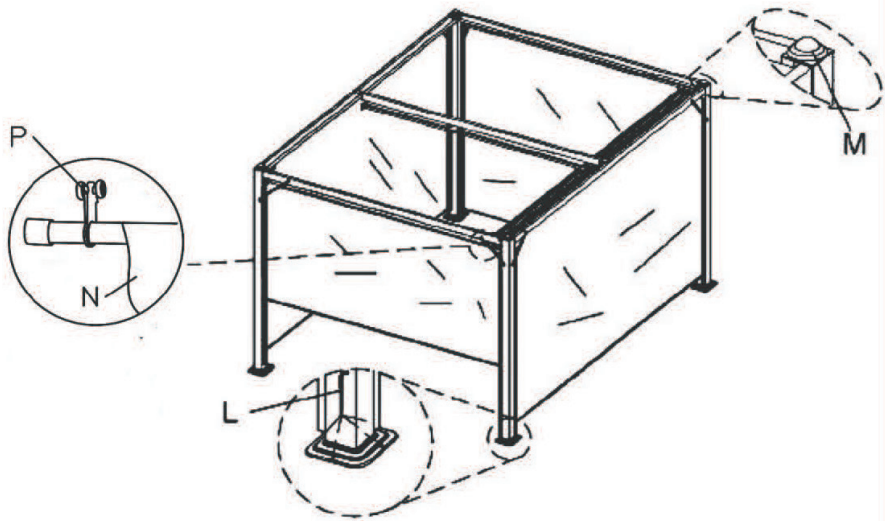

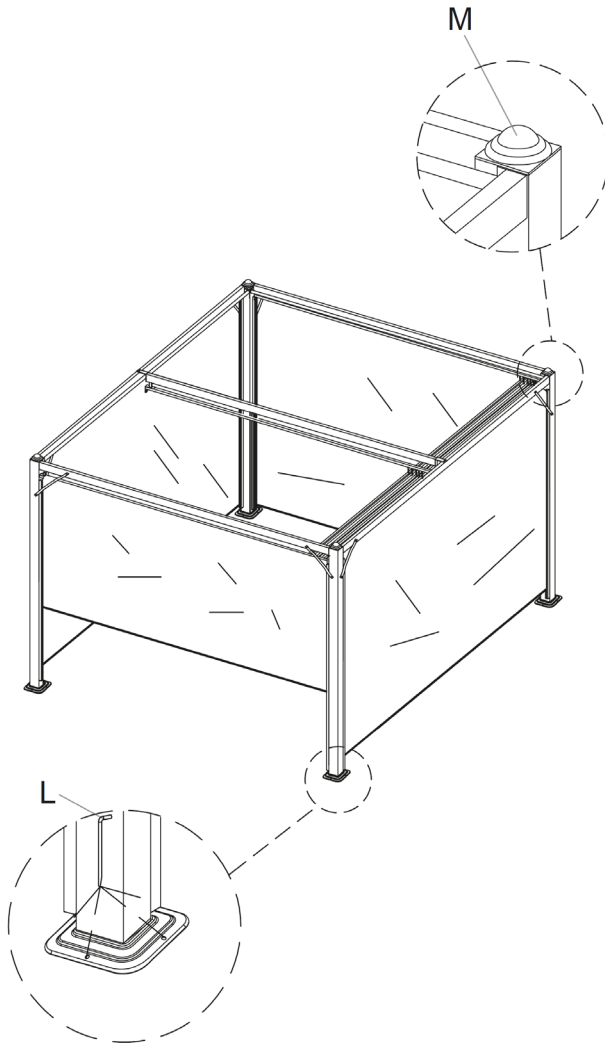

DE Wiederholen Sie den im Kreis beschriebenen Vorgang an allen 4 Enden.

EN Repeat the process described in the circle on all 4 ends.

ES Repita el proceso descrito en el círculo en los 4 extremos.

FR Répétez le processus décrit dans le cercle pour les 4 extrémités.

IT Ripetere il procedimento descritto nel cerchio a tutte e 4 le estremità.

HERSTELLER

Manufacturer | Fabricante | Fabricant | Produttore

Chal-Tec GmbH, Wallstraße 16, 10179 Berlin, Deutschland (Germany).

IMPORTEUR FÜR GROSSBRITANNIEN

Importer for Great Britain | Importador para Gran Bretaña | Importateur pour la Grande Bretagne | Importatore per la Gran Bretagna

Berlin Brands Group UK Limited
PO Box 42
272 Kensington High Street
London, W8 6ND
United Kingdom

