



blumfeldt

Pantheon Solid Sky Ambient Solar 3x3

Pergola

10035899 10035900 10035901
10035902 10035903 10035904



Sehr geehrter Kunde,

wir gratulieren Ihnen zum Erwerb Ihres Gerätes. Lesen Sie die folgenden Hinweise sorgfältig durch und befolgen Sie diese, um möglichen Schäden vorzubeugen. Für Schäden, die durch Missachtung der Hinweise und unsachgemäßen Gebrauch entstehen, übernehmen wir keine Haftung. Scannen Sie den folgenden QR-Code, um Zugriff auf die aktuellste Bedienungsanleitung und weitere Informationen rund um das Produkt zu erhalten:

**Dear Customer,**

Congratulations on purchasing this device. Please read the following instructions carefully and follow them to prevent possible damages. We assume no liability for damage caused by disregard of the instructions and improper use. Scan the QR code to get access to the latest user manual and more product information.

**Estimado cliente,**

Le felicitamos por la adquisición de este producto. Lea atentamente las siguientes instrucciones y sígalas para evitar posibles daños. No asumimos ninguna responsabilidad por los daños causados por el incumplimiento de las instrucciones y el uso inadecuado. Escanee el siguiente código QR para obtener acceso a la última guía del usuario y más información sobre el producto.

**Chère cliente, cher client,**

Toutes nos félicitations pour l'acquisition de ce nouvel appareil. Veuillez lire attentivement et respecter les instructions de ce mode d'emploi afin d'éviter d'éventuels dommages. Nous ne saurions être tenus pour responsables des dommages dus au non-respect des consignes et à la mauvaise utilisation de l'appareil. Scannez le QR-Code pour obtenir la dernière version du mode d'emploi et des informations supplémentaires concernant le produit.

**Gentile cliente,**

La ringraziamo per aver acquistato il dispositivo. La preghiamo di leggere attentamente le seguenti istruzioni per l'uso e di seguirle per evitare possibili danni. Non ci assumiamo alcuna responsabilità per danni scaturiti da una mancata osservazione delle avvertenze di sicurezza e da un uso improprio del dispositivo. Scansionare il codice QR seguente, per accedere al manuale d'uso più attuale e per ricevere informazioni sul prodotto.



TECHNISCHE DATEN

Artikelnummer	10035899, 10035900, 10035901, 10035902, 10035903, 10035904
Solarpanel	
Leistung	1 W
Elektrische Spannung	5V
Elektrische Stromstärke	200 mA
Anzahl	1
Akku	
Leistung	18650 Lithium-Akku
Leistung	9,62 W
Elektrische Spannung	3,7 V
Elektrische Stromstärke	Kapazität 2600 mA
Anzahl	1
Ausgang	
Leistung	0,18-1,5 W
Elektrische Spannung	3 V
Elektrische Stromstärke	60-500 mA
Betriebszeit (Stunden) (bei vollständiger Aufladung)	5-12 h
LED	
Leistung	2835 (weißes Licht)
Leistung	0,2 W
Elektrische Spannung	3 V
Elektrische Stromstärke	60 mA
Anzahl	56

TECHNICAL DATA

Item number	10035899, 10035900, 10035901, 10035902, 10035903, 10035904
Solar panel	
Power	1 W
Electric voltage	5V
Electric current	200 mA
Quantity	1
Battery	
	18650 Lithium battery
Power	9.62 W
Electric voltage	3.7 V
Electric current	Capacity 2600 mA
Quantity	1
Output	
Power	0.18-1.5 W
Electric voltage	3 V
Electric current	60-500 mA
Operating time (hours) (when fully charged)	5-12 h
LED	
	2835 (white light)
Power	0.2 W
Electric voltage	3 V
Electric current	60 mA
Quantity	56

DATOS TÉCNICOS

Número de artículo	10035899, 10035900, 10035901, 10035902, 10035903, 10035904
Panel solar	
Potencia	1 W
Voltaje eléctrico	5V
Corriente eléctrica	200 mA
Cantidad	1
Batería	
	18650 Batería de litio
Potencia	9,62 W
Voltaje eléctrico	3,7 V
Corriente eléctrica	Capacidad 2600 mA
Cantidad	1
Salida	
Potencia	0,18-1,5 W
Voltaje eléctrico	3 V
Corriente eléctrica	60-500 mA
Tiempo de funcionamiento (horas) (cuando está totalmente cargado)	5-12 h
LED	
	2835 (luz blanca)
Potencia	0,2 W
Voltaje eléctrico	3 V
Corriente eléctrica	60 mA
Cantidad	56

FICHE TECHNIQUE

















Numéro d'article	10035899, 10035900, 10035901, 10035902, 10035903, 10035904
Panneau solaire	
Puissance	1 W
Tension électrique	5V
Courant électrique	200 mA
Quantité	1
Batterie	
Puissance	9,62 W
Tension électrique	3,7 V
Courant électrique	Capacité 2600 mA
Quantité	1
Sortie	
Puissance	0,18-1,5 W
Tension électrique	3 V
Courant électrique	60-500 mA
Temps de fonctionnement (heures) (lorsqu'il est complètement chargé)	5-12 h
LED	
Puissance	0,2 W
Tension électrique	3 V
Courant électrique	60 mA
Quantité	56







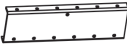



DATI TECNICI









Numero articolo	10035899, 10035900, 10035901, 10035902, 10035903, 10035904
Pannello solare	
Potenza	1 W
Tensione elettrica	5V
Corrente elettrica	200 mA
Quantità	1
Batteria	18650 Batteria al litio
Potenza	9,62 W
Tensione elettrica	3,7 V
Corrente elettrica	Capacità 2600 mA
Quantità	1
Uscita	
Potenza	0,18-1,5 W
Tensione elettrica	3 V
Corrente elettrica	60-500 mA
Tempo di funzionamento (ore) (quando e' completamente carico)	5-12 h
LED	2835 (luce bianca)
Potenza	0,2 W
Tensione elettrica	3 V
Corrente elettrica	60 mA
Quantità	56

LIEFERUMFANG

Scope of delivery | Volumen de suministro | Contenu de la livraison |
Dotazione di fornitura

A		4
B		4
C		4
D		4
E		4
F		4
G		4
H		12
I		4
J		4
K		4
L		4
M		4
N		4
O		4
P		4

Q		4
R		1
S		1
T		4
U		8
V		4
W		4
X		4
Y		4
Z		112

①	 M5*12 mm	32+1
②	 M6*15 mm	137+2
③	 M6*12 mm	24+1
④		1
⑤		1
⑥		1
⑦		1
⑧		12



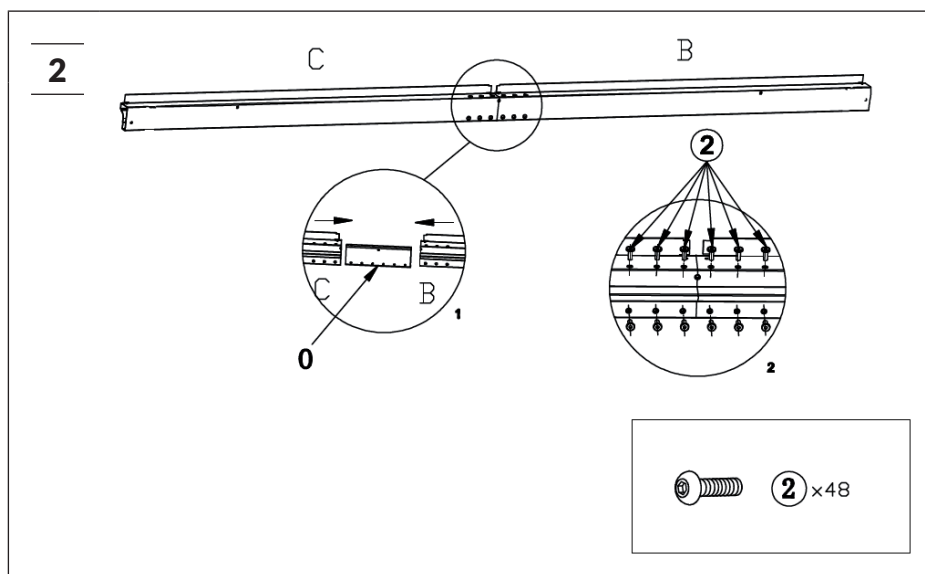
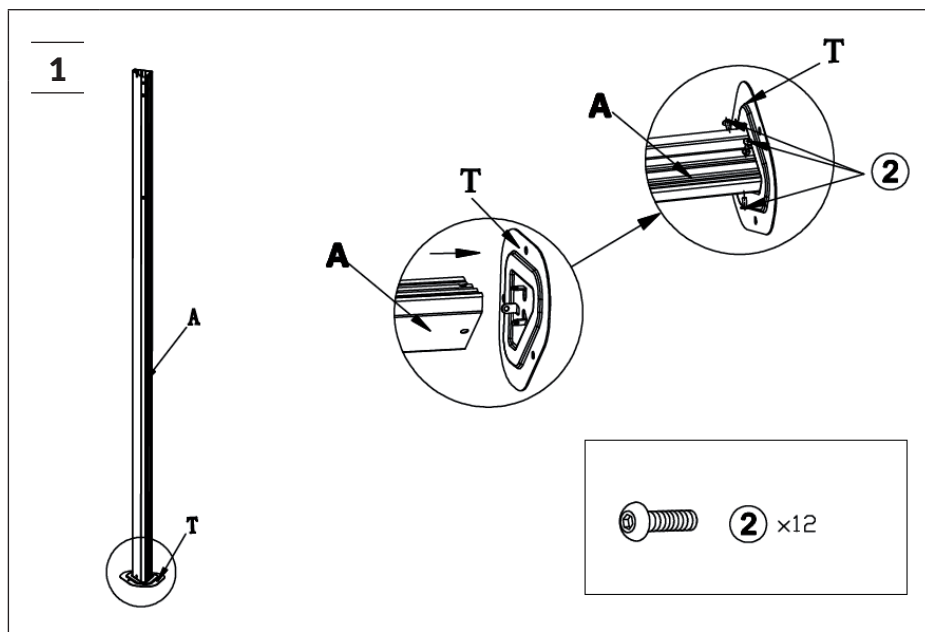

ZUSAMMENBAU

Assembly | Ensamblaje | Assemblée | Assemblaggio

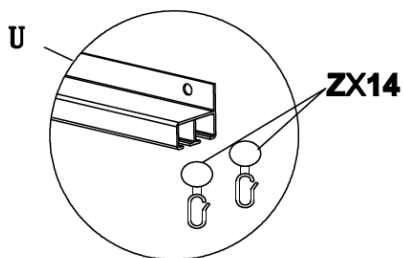
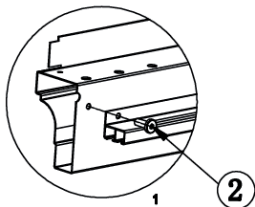
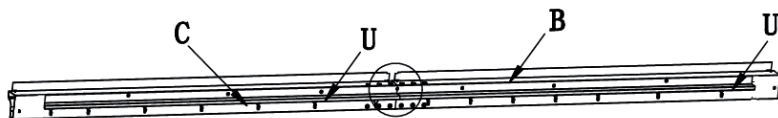

3



	B X4		Z X112
	C X4		
	U X8		(2) X24

4

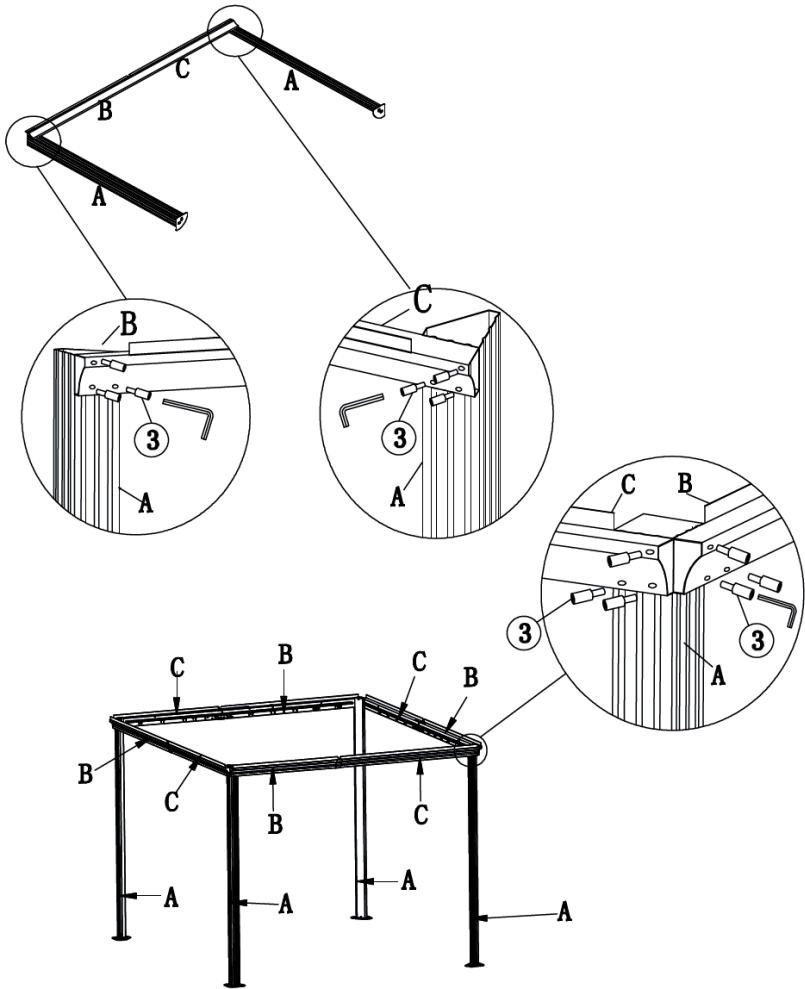

 (3) X24

5

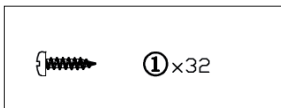
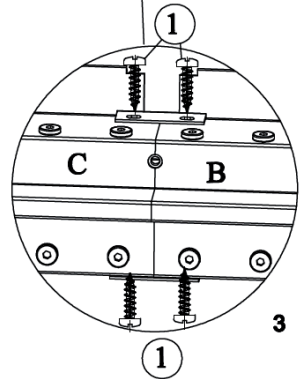
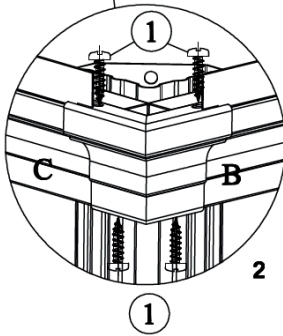
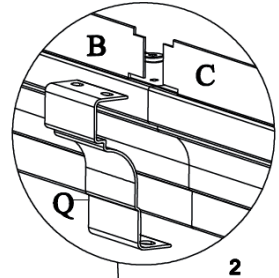
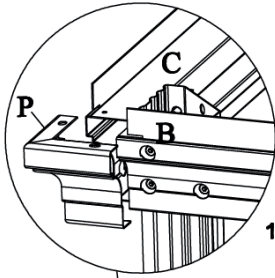
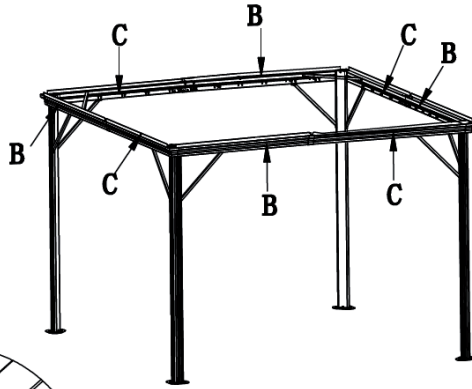

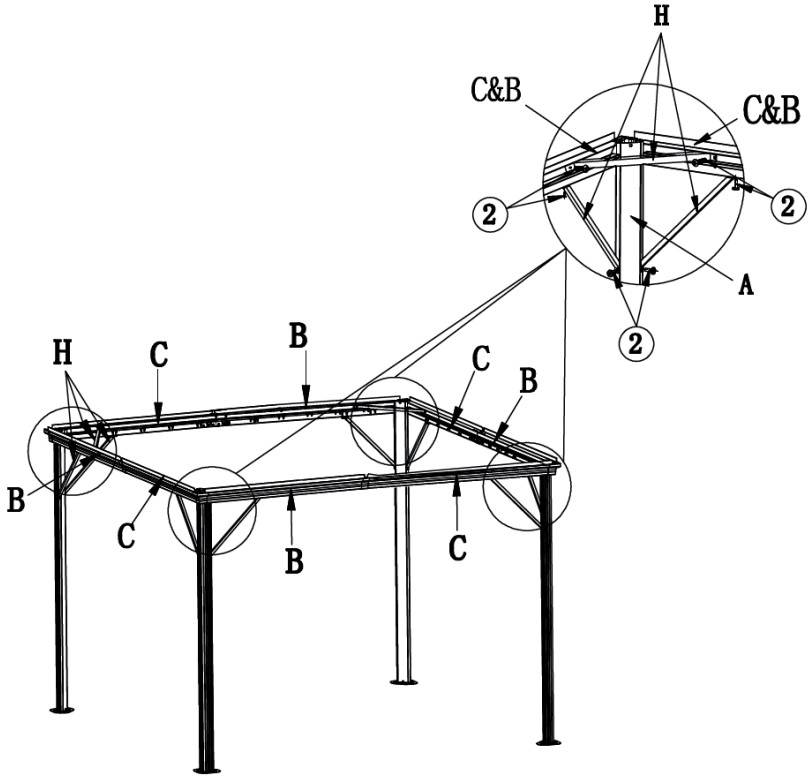

H X12



② X 24

7

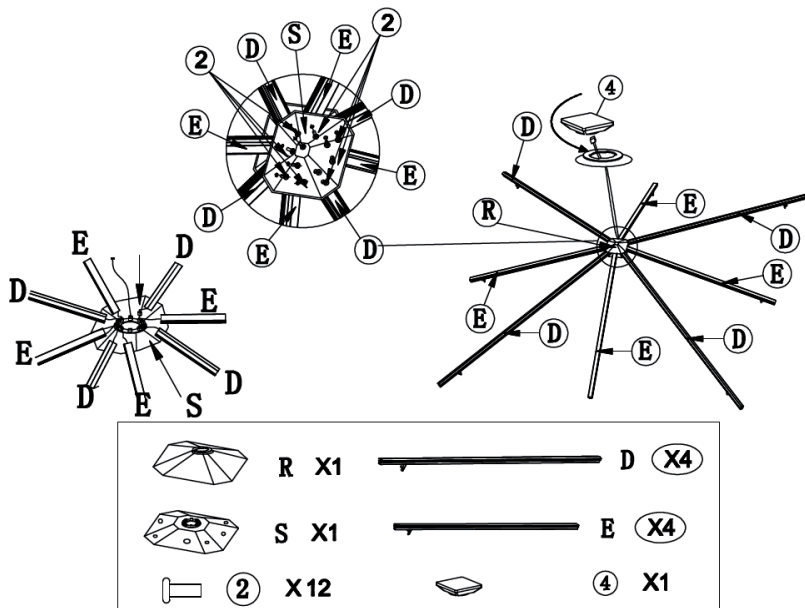

8

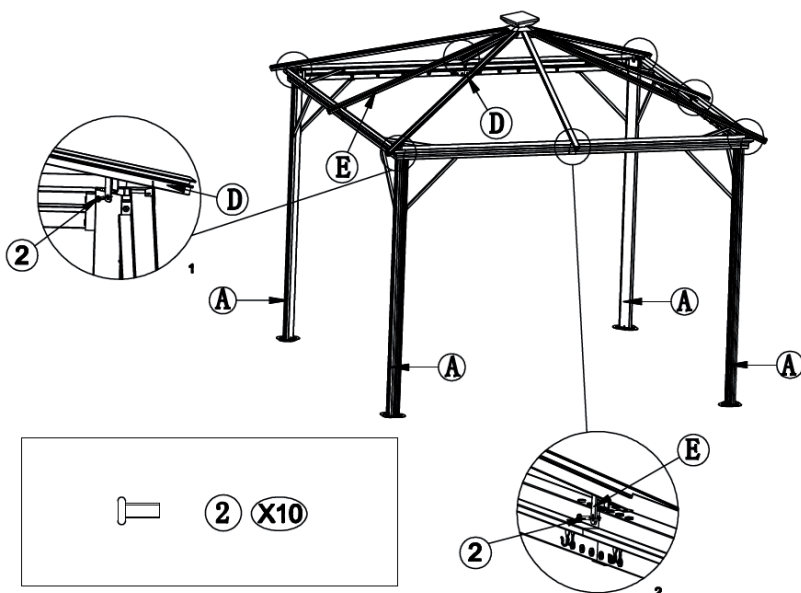

9

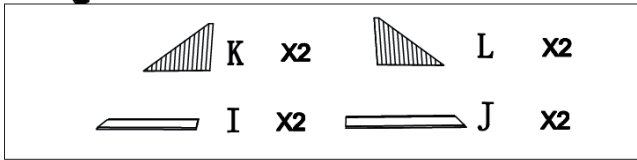
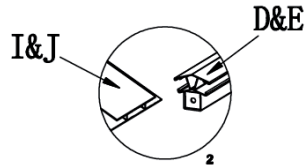
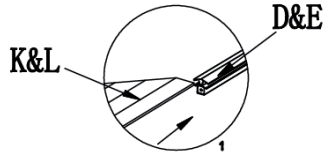
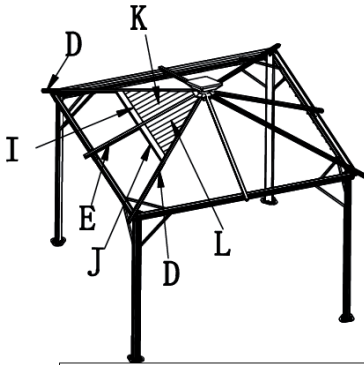

10

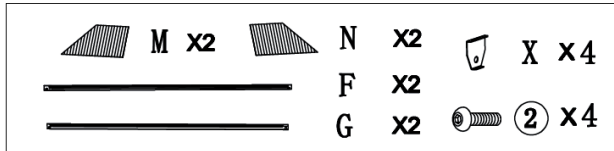
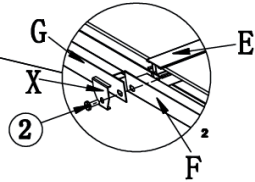
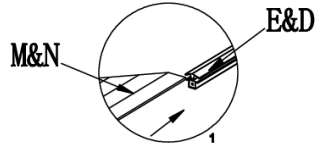
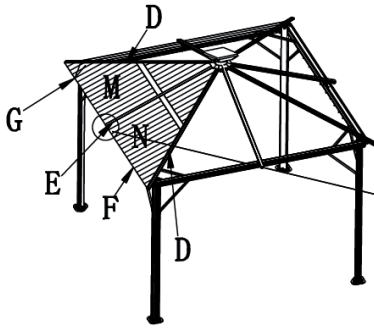

11

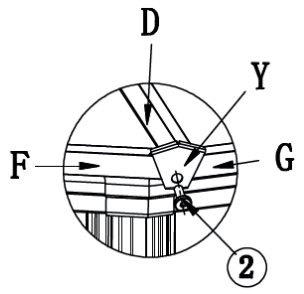

 Y X4

 2 X4

12

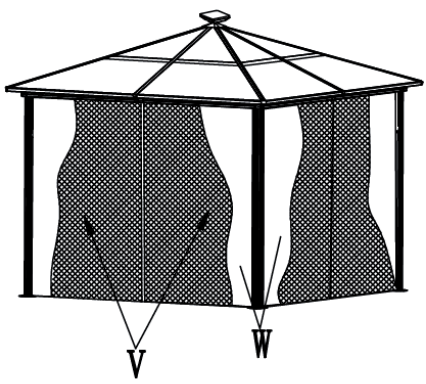
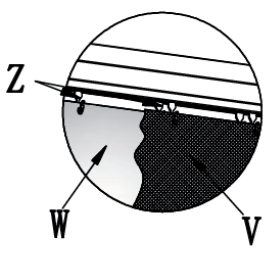

 W X4

 V X4

13

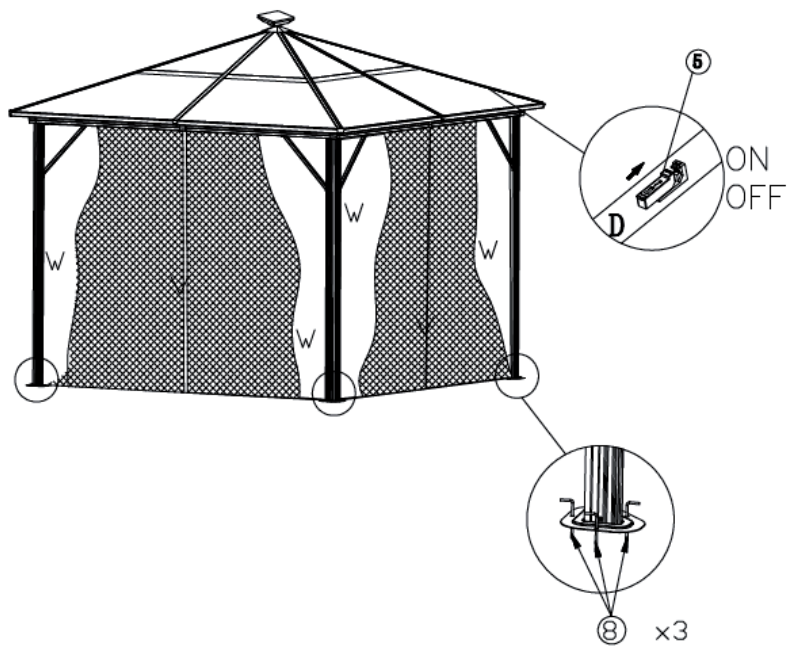

8 X12



5 X 1

HINWEISE ZUR ENTSORGUNG



Wenn es in Ihrem Land eine gesetzliche Regelung zur Entsorgung von elektrischen und elektronischen Geräten gibt, weist dieses Symbol auf dem Produkt oder auf der Verpackung darauf hin, dass dieses Produkt nicht im Hausmüll entsorgt werden darf. Stattdessen muss es zu einer Sammelstelle für das Recycling von elektrischen und elektronischen Geräten gebracht werden. Durch regelkonforme Entsorgung schützen Sie die Umwelt und die Gesundheit Ihrer Mitmenschen vor negativen Konsequenzen. Informationen zum Recycling und zur Entsorgung dieses Produkts, erhalten Sie von Ihrer örtlichen Verwaltung oder Ihrem Hausmüllentsorgungsdienst.

Dieses Produkt enthält Batterien. Wenn es in Ihrem Land eine gesetzliche Regelung zur Entsorgung von Batterien gibt, dürfen die Batterien nicht im Hausmüll entsorgt werden. Informieren Sie sich über die örtlichen Bestimmungen zur Entsorgung von Batterien. Durch regelkonforme Entsorgung schützen Sie die Umwelt und die Gesundheit Ihrer Mitmenschen vor negativen Konsequenzen.

HERSTELLER & IMPORTEUR (UK)

Hersteller:

Chal-Tec GmbH, Wallstraße 16, 10179 Berlin, Deutschland.

Importeur für Großbritannien:

Chal-Tec UK limited
Unit 6 Riverside Business Centre
Brighton Road
Shoreham-by-Sea
BN43 6RE
United Kingdom

DISPOSAL CONSIDERATIONS



If there is a legal regulation for the disposal of electrical and electronic devices in your country, this symbol on the product or on the packaging indicates that this product must not be disposed of with household waste. Instead, it must be taken to a collection point for the recycling of electrical and electronic equipment. By disposing of it in accordance with the rules, you are protecting the environment and the health of your fellow human beings from negative consequences. For information about the recycling and disposal of this product, please contact your local authority or your household waste disposal service.

This product contains batteries. If there is a legal regulation for the disposal of batteries in your country, the batteries must not be disposed of with household waste. Find out about local regulations for disposing of batteries. By disposing of them in accordance with the rules, you are protecting the environment and the health of your fellow human beings from negative consequences.

MANUFACTURER & IMPORTER (UK)

Manufacturer:

Chal-Tec GmbH, Wallstrasse 16, 10179 Berlin, Germany.

Importer for Great Britain:

Chal-Tec UK limited
Unit 6 Riverside Business Centre
Brighton Road
Shoreham-by-Sea
BN43 6RE
United Kingdom

INDICACIONES SOBRE LA RETIRADA DEL APARATO



Si en su país existe una disposición legal relativa a la eliminación de aparatos eléctricos y electrónicos, este símbolo estampado en el producto o en el embalaje advierte que no debe eliminarse como residuo doméstico. En lugar de ello, debe depositarse en un punto de recogida de reciclaje de aparatos eléctricos y electrónicos. Una gestión adecuada de estos residuos previene consecuencias potencialmente negativas para el medio ambiente y la salud de las personas. Puede consultar más información sobre el reciclaje y la eliminación de este producto contactando con su administración local o con su servicio de recogida de residuos.

Este producto contiene baterías. Si en su país existe una disposición legal relativa a la eliminación de baterías, estas no deben eliminarse como residuo doméstico. Infórmese sobre la normativa vigente relacionada con la eliminación de baterías. Una gestión adecuada de estos residuos previene consecuencias potencialmente negativas para el medio ambiente y la salud de las personas.

FABRICANTE E IMPORTADOR (REINO UNIDO)

Fabricante:

Chal-Tec GmbH, Wallstraße 16, 10179 Berlín, Alemania.

Importador para Gran Bretaña:

Chal-Tec UK limited
Unit 6 Riverside Business Centre
Brighton Road
Shoreham-by-Sea
BN43 6RE
United Kingdom

INFORMATIONS SUR LE RECYCLAGE



S'il existe une réglementation pour l'élimination ou le recyclage des appareils électriques et électroniques dans votre pays, ce symbole sur le produit ou sur l'emballage indique que cet appareil ne doit pas être jeté avec les ordures ménagères. Vous devez le déposer dans un point de collecte pour le recyclage des équipements électriques et électroniques. La mise au rebut conforme aux règles protège l'environnement et la santé de vos semblables des conséquences négatives. Pour plus d'informations sur le recyclage et l'élimination de ce produit, veuillez contacter votre autorité locale ou votre service de recyclage des déchets ménagers.

Ce produit contient des piles. S'il existe une réglementation pour l'élimination ou le recyclage des piles dans votre pays, vous ne devez pas les jeter avec les ordures ménagères. Renseignez-vous sur les dispositions locales relatives à la collecte des piles usagées. La mise au rebut conforme aux règles protège l'environnement et la santé de vos semblables des conséquences négatives.

FABRICANT ET IMPORTATEUR (UK)

Fabricant :

Chal-Tec GmbH, Wallstraße 16, 10179 Berlin, Allemagne.

Importateur pour la Grande Bretagne :

Chal-Tec UK limited
Unit 6 Riverside Business Centre
Brighton Road
Shoreham-by-Sea
BN43 6RE
United Kingdom

AVVISO DI SMALTIMENTO



Se nel proprio paese si applicano le regolamentazioni inerenti lo smaltimento di dispositivi elettrici ed elettronici, questo simbolo sul prodotto o sulla confezione segnala che questi prodotti non possono essere smaltiti con i rifiuti normali e devono essere portati a un punto di raccolta di dispositivi elettrici ed elettronici. Grazie al corretto smaltimento dei vecchi dispositivi si tutela il pianeta e la salute delle persone da possibili conseguenze negative. Informazioni riguardanti il riciclo e lo smaltimento di questi prodotti si ottengono presso l'amministrazione locale oppure il servizio di gestione dei rifiuti domestici.

Il prodotto contiene batterie. Se nel proprio paese si applicano le regolamentazioni inerenti lo smaltimento di batterie, non possono essere smaltite con i normali rifiuti domestici. Preghiamo di informarvi sulle regolamentazioni vigenti sullo smaltimento delle batterie. Grazie al corretto smaltimento dei vecchi dispositivi si tutela l'ambiente e la salute delle persone da conseguenze negative.

PRODUTTORE E IMPORTATORE (UK)

Produttore:

Chal-Tec GmbH, Wallstraße 16, 10179 Berlino, Germania.

Importatore per la Gran Bretagna:

Chal-Tec UK limited
Unit 6 Riverside Business Centre
Brighton Road
Shoreham-by-Sea
BN43 6RE
United Kingdom

