



blumfeldt



## Climax Ambient

Pergola

10035942 10035943 10035944 10035945



**Sehr geehrter Kunde,**

wir gratulieren Ihnen zum Erwerb Ihres Gerätes. Lesen Sie die folgenden Hinweise sorgfältig durch und befolgen Sie diese, um möglichen Schäden vorzubeugen. Für Schäden, die durch Missachtung der Hinweise und unsachgemäßen Gebrauch entstehen, übernehmen wir keine Haftung. Scannen Sie den folgenden QR-Code, um Zugriff auf die aktuellste Bedienungsanleitung und weitere Informationen rund um das Produkt zu erhalten:

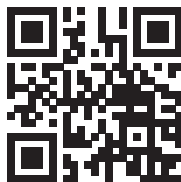

---

## INHALTSVERZEICHNIS

---

Einzelteile 4
Zusammenbau 7
Installation des Solarpanels 26
Hinweise zum Lithium-Ionen-Akku 27
Benutzung der Fernbedienung 29
Installation des LED-Controllers 30
Spezielle Entsorgungshinweise für Verbraucher in Deutschland 33
Hinweise zur Entsorgung 35
Hersteller & Importeur (UK) 35

English 37
Français 69
Español 101
Italiano 133

















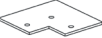

---

## TECHNISCHE DATEN







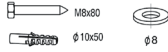

---

Artikelnummer	10035942 10035943	10035944 10035945
Abmessungen	3x3 m	3x4 m

## EINZELTEILE

Nr.	Beschreibung	Bild	Stk.
A	Säule		4
B1	Balken (links)		1
B2	Balken (rechts)		1
C	Balken (vorn & hinten)		2
D	Mittlerer Balken		1
E	Lamelle		3x3=44 3x4=60
F	Säulenbodenplatte		4
G	Säulenabdeckplatte		4
H	Verbindungsstück für den mittleren Balken		2
I	Scharnierring		2
J	Handkurbel		2
K1	Senkkopfschraube	 M6x16	40+2
K2	Flachkopfschraube	 M6x16	20+2
K3	Unterlegscheibe	 D6x12	8+2
K4	Schraube & Mutter	 M4x25	2
K5	Selbstbohrende Schraube	 ST4.2x25	8
K8	Schraube	 ST4.8x10	4
K9	Schraube	 M5x12	2
K10	Mutter	 M5	2



Nr.	Beschreibung	Bild	Stk.
L	Holzschraube, Dübel und Unterlegscheibe		16
M	Glaskleber		1
N	Abdeckung aus Kunststoff		3x3=88 3x4=120
P	Fernbedienung		1
Q	Drainageanschluss		4
R	Klammer		1
S	Halterung		4
T	Solarpanel		1
H	Batterie		1

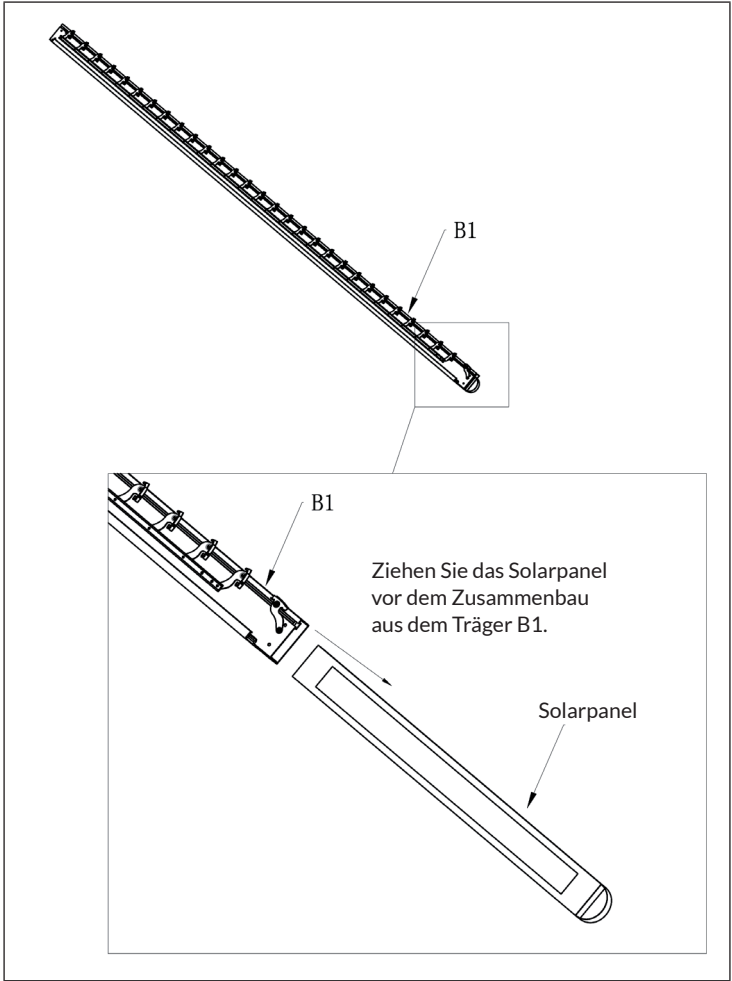

# ZUSAMMENBAU

Hinweis zu den Angaben in den Bildern: QTY = Menge / PCS = Stück

1

## Verbinden Sie den Drainageanschluss mit der Säule

Klemmen Sie den Drainageanschluss (Q) in den Säulenschlitz. Verbinden Sie dann die Bodenplatte mit der Säule (A) und ziehen Sie die Schrauben fest. Führen Sie diese Schritte bei allen 4 Säulen durch.

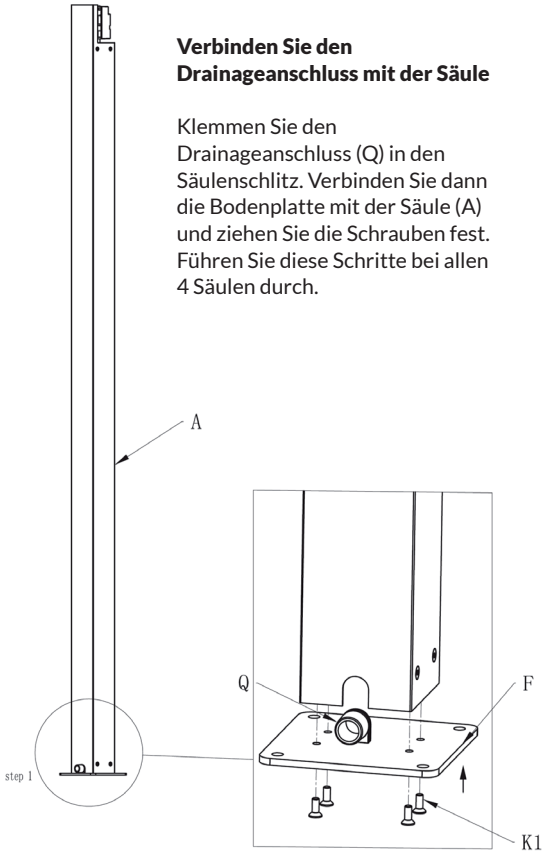

K1  QTY: 16PCS

F  QTY: 4PCS

Q  QTY: 4PCS

Passen Sie das Verbindungsstück (H) an einer Seite des mittleren Balkens (D) an. Ziehen Sie dann die Schraube (K1) an. Führen Sie die selben Schritte auf der anderen Seite des Balkens durch.

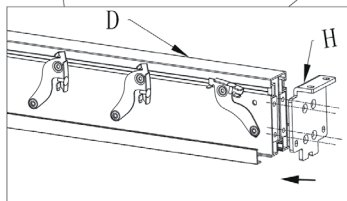
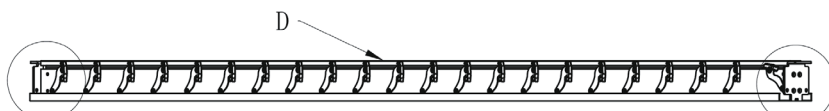

**Schritt 1**

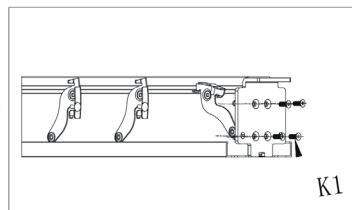

**Schritt 2**

K1

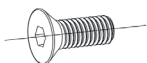

QTY:8PCS

H

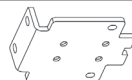

QTY:2PCS

Setzen Sie die zwei Scharnerringe (I) in die Antriebswelle am Balken (D) ein und befestigen Sie die Scharnerringe mit jeweils einer Schraube und einer Mutter (K4).

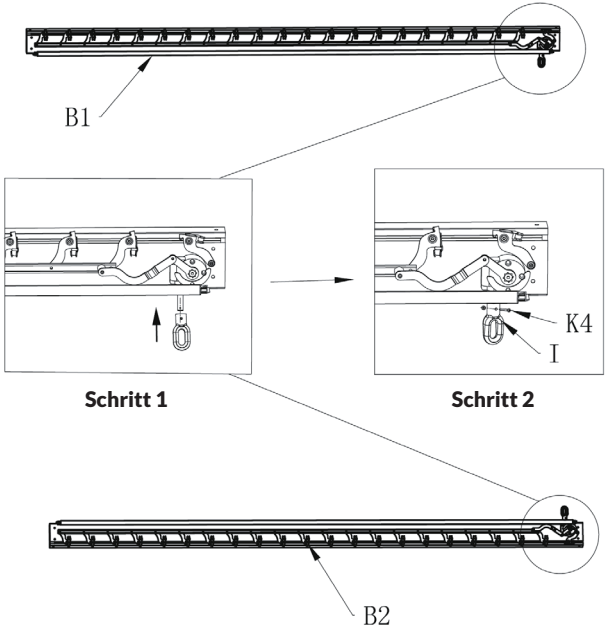

- |   |  |          |    |    |  |  |       |            |
|---|--|----------|----|----|--|--|-------|------------|
| I |  | QTY:2PCS | K4 | M4 |  |  | M4x25 | QTY:2 SETS |
|---|--|----------|----|----|--|--|-------|------------|

Platzieren Sie die Säulen und den Balken wie in der Abbildung gezeigt und achten Sie darauf, dass der Ablaufanschluss der Säulen immer zur gleichen Seite zeigt.

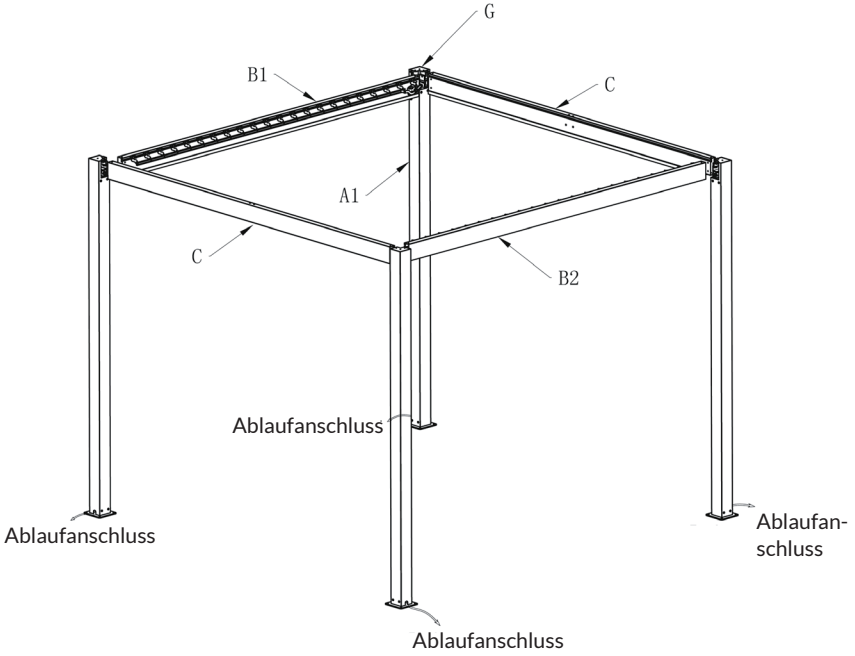

5

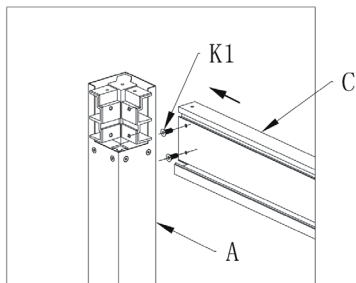

Setzen Sie die beiden Enden des vorderen und hinteren Balkens (C) jeweils auf die Eckverbinder an der Säule und ziehen Sie die Schrauben (K1) an.

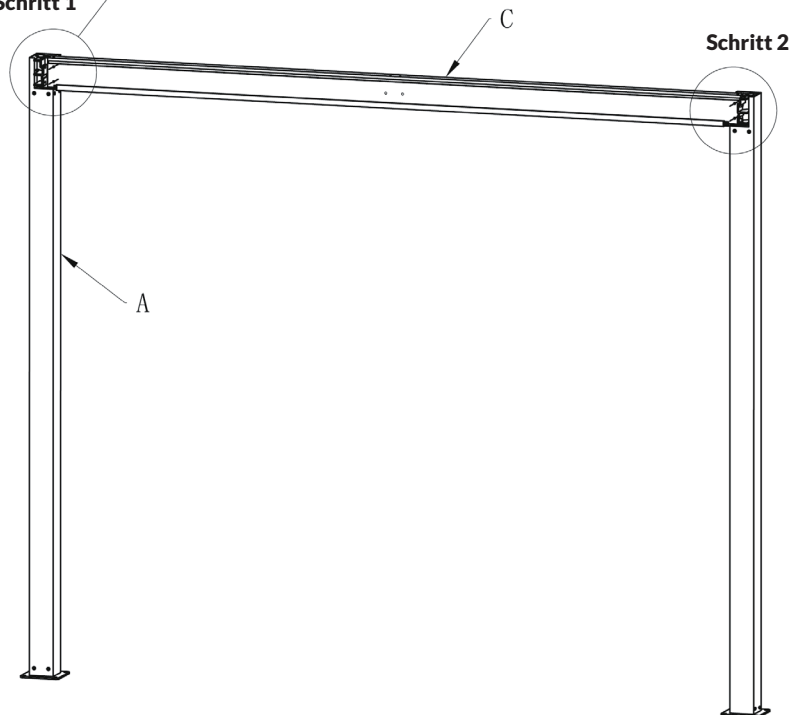
**Schritt 1****Schritt 2**

K1

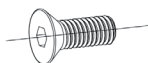

QTY:4PCS

Setzen Sie den linken und rechten Balken (B1&B2) jeweils auf die Eckverbinder an den Säulen und befestigen Sie die Balken mit Schrauben (K1).

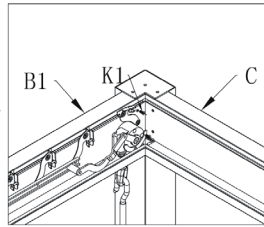
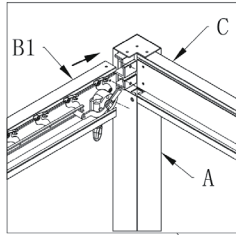

Schritt 1

Schritt 2

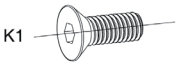
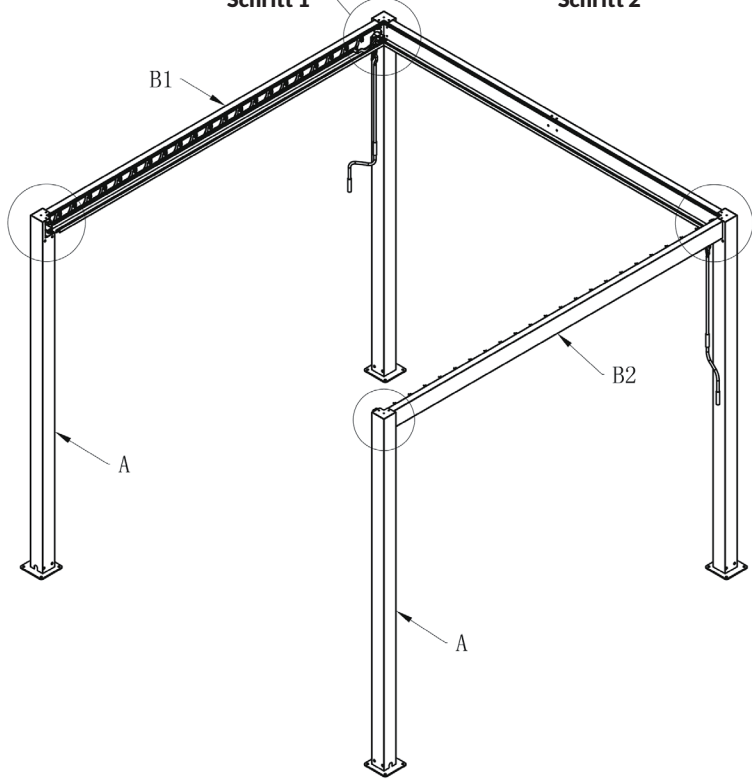

QTY:8PCS



7

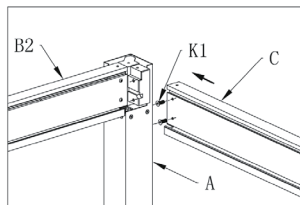

Setzen Sie den Balken (C) auf die Eckverbinder an den Säulen und befestigen Sie den Balken ebenfalls mit Schrauben (K1).

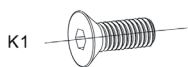
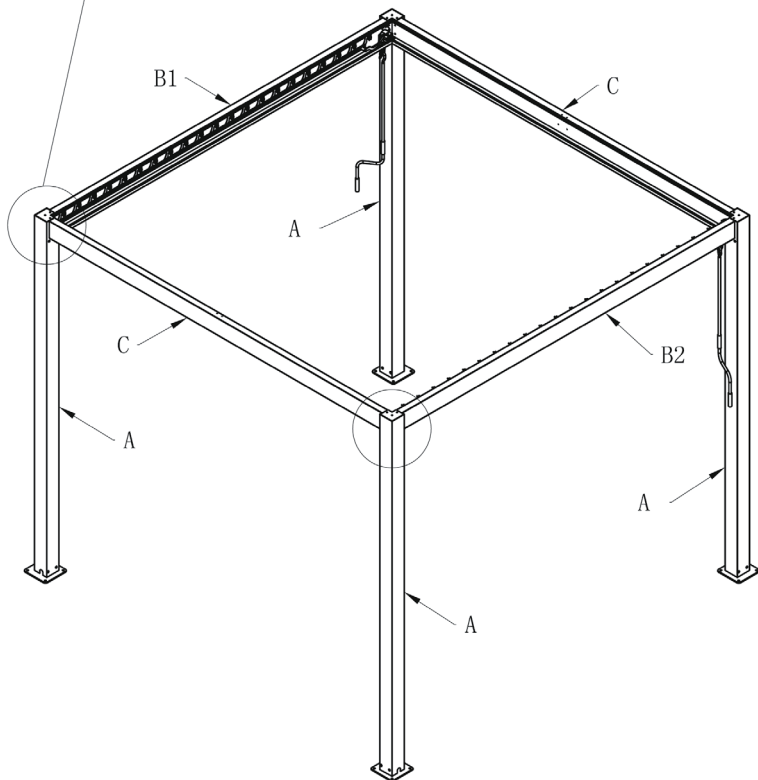

QTY:4PCS

8

Setzen Sie die 4 Säulenabdeckplatten (G) auf die Eckverbinder der Säule und Befestigen Sie die Abdeckplatten mit Schrauben (K2).

**Schritt 1**      **Schritt 2**

**K2**      **G**

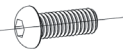
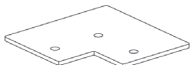
<p><b>K2</b>  QTY:12PCS</p>	<p><b>G</b>  QTY:4PCS</p>
--	--

Stellen Sie die vier Säulen so auf, dass sie senkrecht zum Boden stehen. Der Abstand der Säumen sollte oben und unten jeweils genau gleich sein. Markieren Sie dann mit einem Markierungsstift 16 Löcher auf dem Boden, die mit den Löchern in der Bodenplatte übereinstimmen sollten.

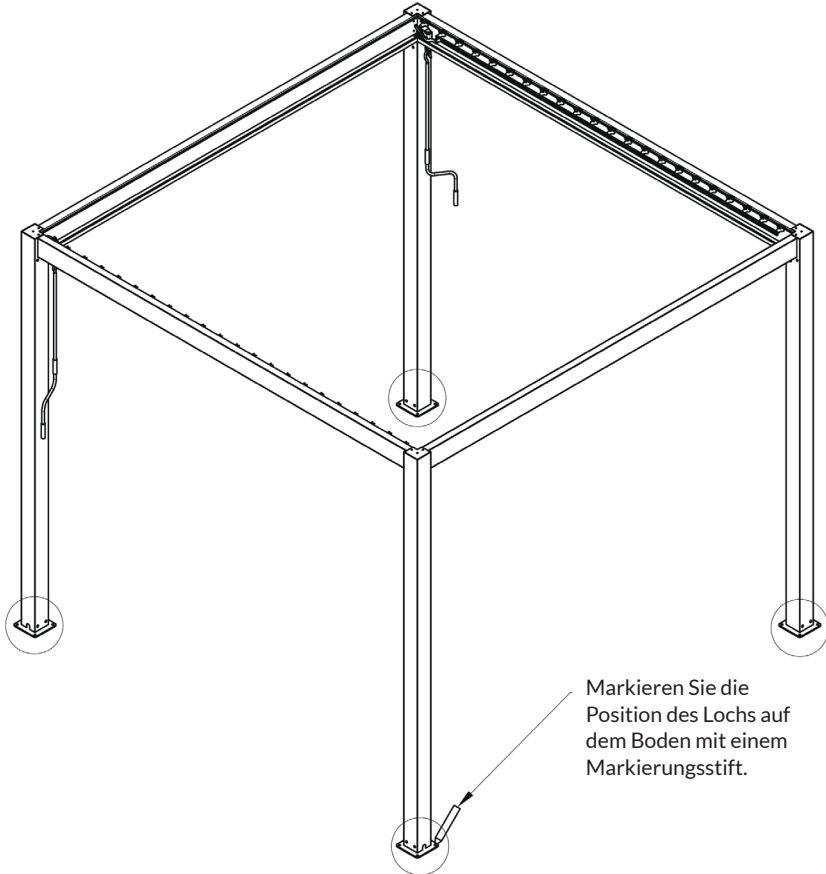

Entfernen Sie das Gestänge von der Markierung und bohren Sie mit einem Schlagbohrer an den 16 Markierungspositionen auf dem Boden Löcher mit dem Durchmesser von 10 mm und einer Tiefe von 80 mm.

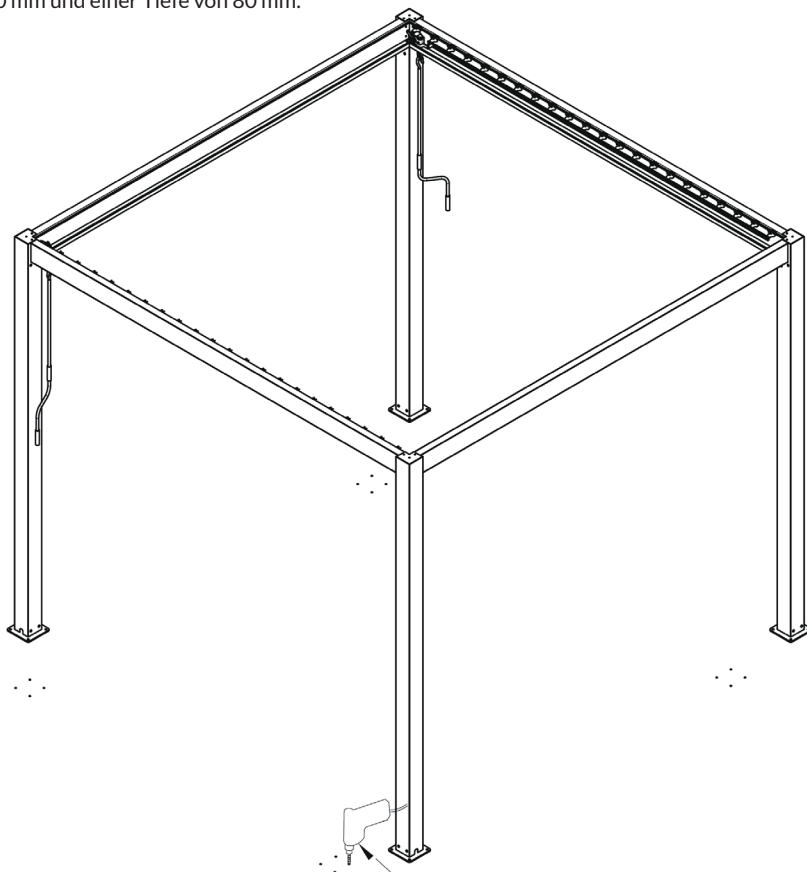

Bohren Sie insgesamt 16 Löcher mit einem Durchmesser von 10 mm und einer Tiefe von 80 mm.

11

Setzen Sie die Dübel in die gebohrte Löcher im Boden ein. Setzen Sie das Gerüst auf die gebohrten Löchern und richten Sie die Löcher der Säulenbodenplatten mit dem gebohrten Löchern am Boden aus. Befestigen Sie die Säulenbodenplatten dann jeweils mit 4 Unterlegscheiben (K6) und 4 Schrauben (L).

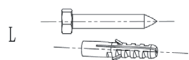
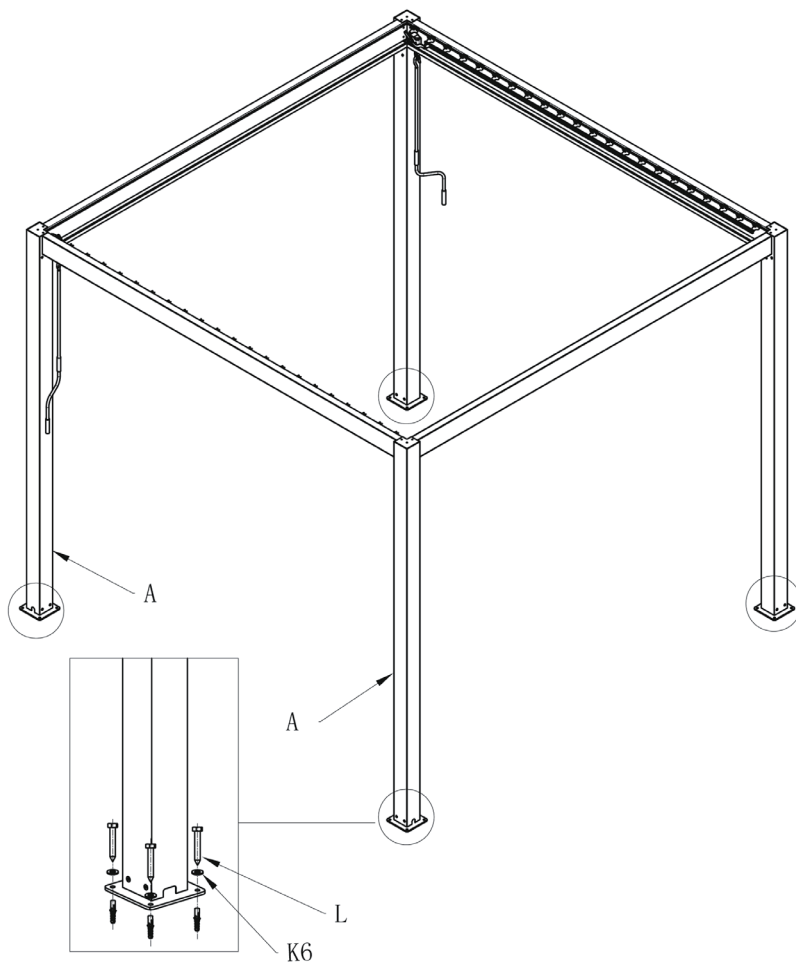

QTY: 16PCS

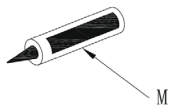
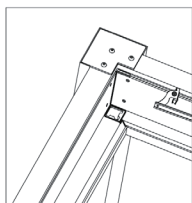

Streichen Sie den Glaskleber (M) gleichmäßig rund um den Ablauf der Säule und die Fugen der Balken (siehe vergrößertes Bild).

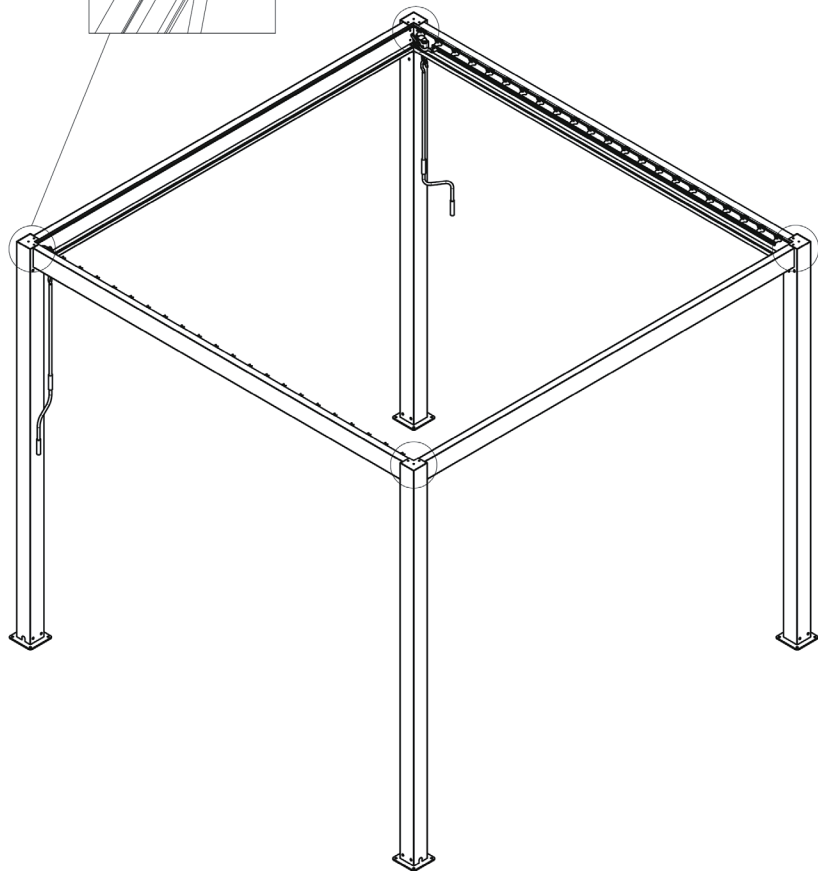

M



QTY: 1PC

13

Legen Sie den mittleren Balken (D) auf den vorderen und hinteren Balken (C).

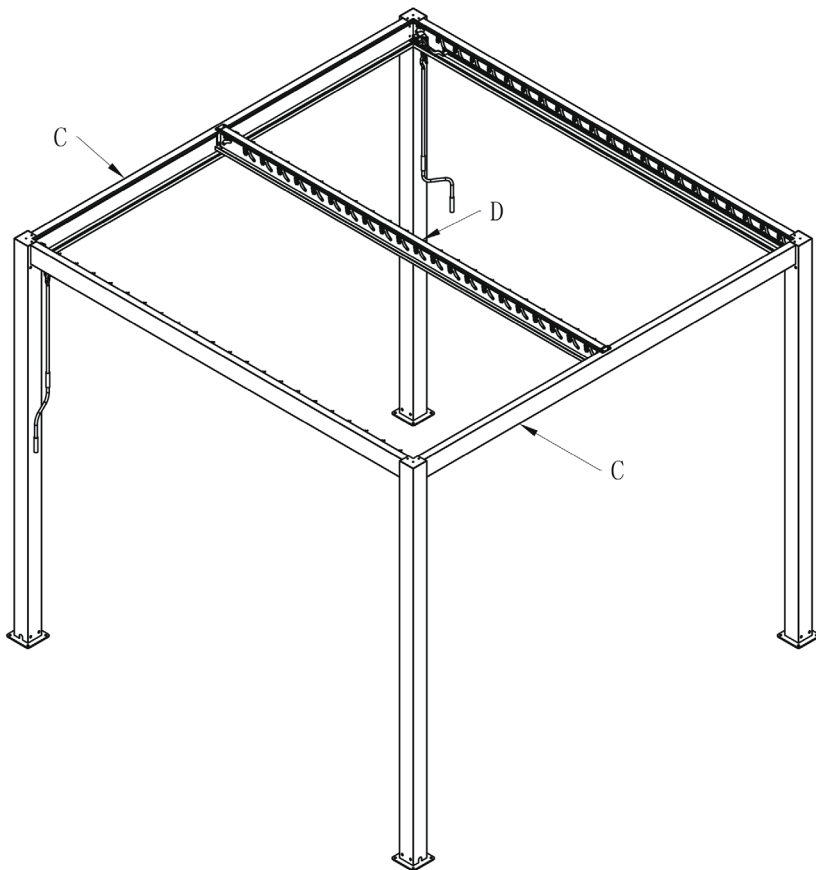

Setzen Sie 6 der Lamellen (E) am Ende der Halterungen auf beiden Seiten der Balken (B1 & B2) ein und drücken Sie die Lamellen nach unten, um sie zu sichern.

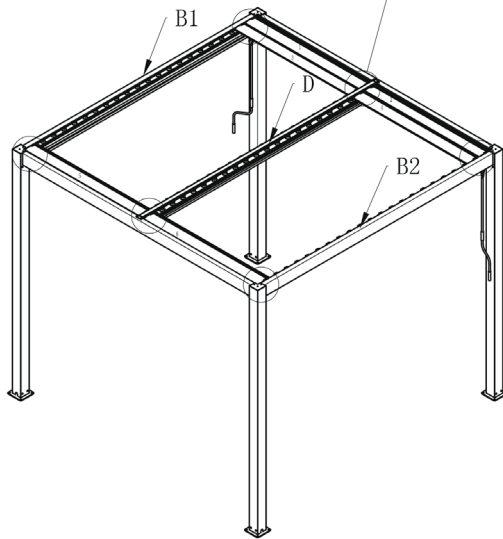
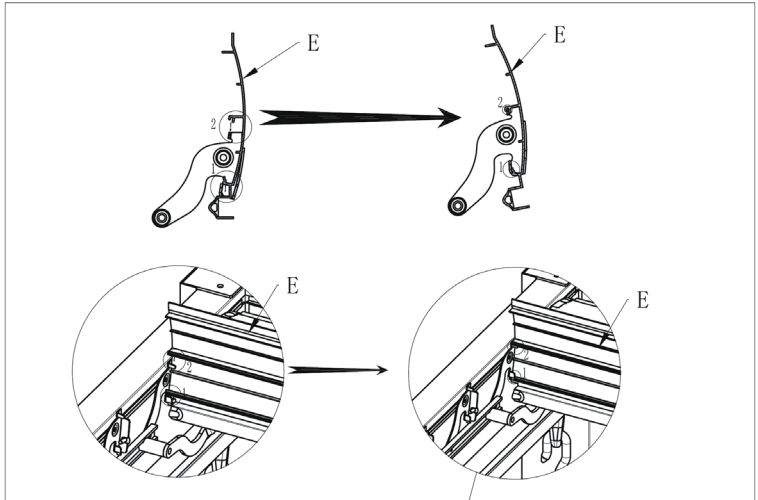



15

Befestigen Sie zuerst die Schraube (K2) mit der Unterlegscheibe (K3) im Loch unter dem Balken (D). Wiederholen Sie diesen Schritt bei Balken (C). Setzen Sie dann die anderen Lamellen der Reihe nach ein.

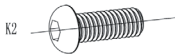
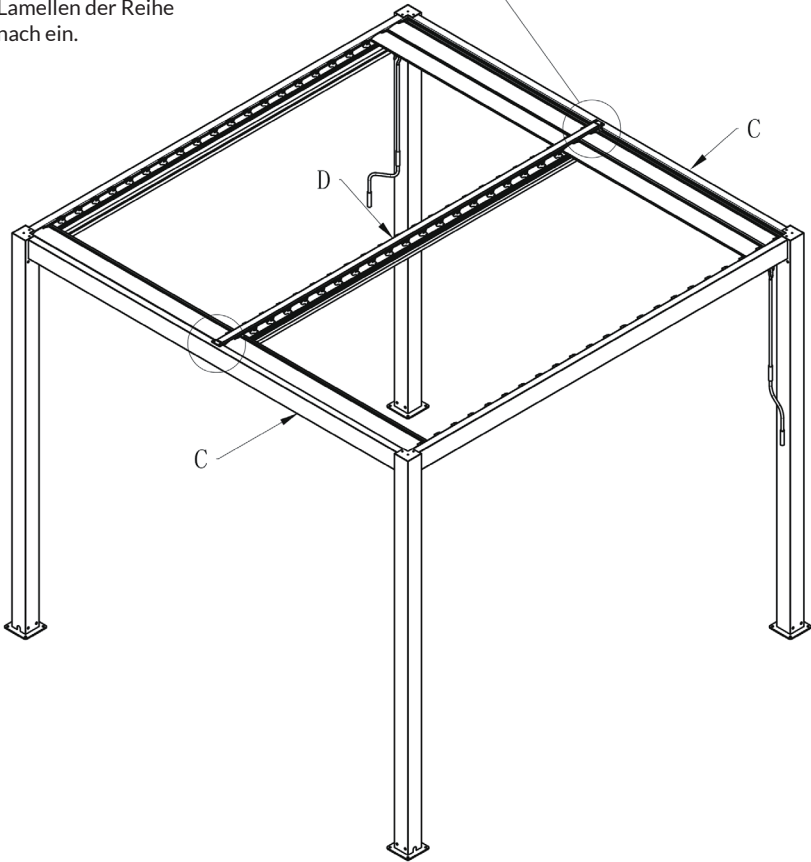
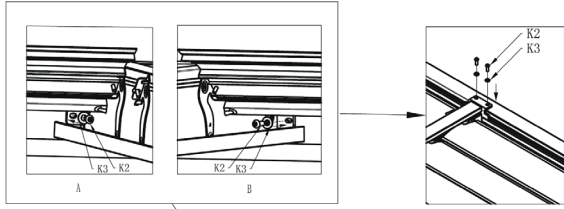

QTY: 8PCS



QTY: 8PCS

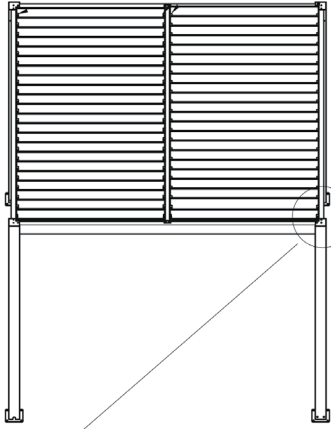

Stellen Sie die Pergola gemäß den folgenden Schritten ein, wenn sie sich nicht vollständig schließen lässt.

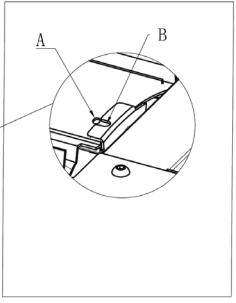
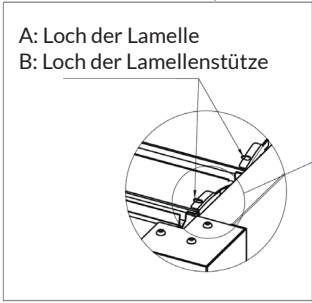

Passen Sie die Installation wie folgt an, wenn Loch A und Loch B nicht richtig übereinander liegen:

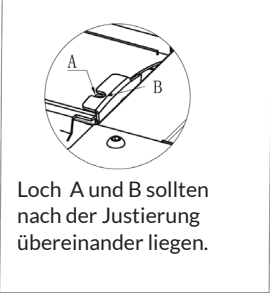

Setzen Sie die Kunststoffabdeckung (N) auf beiden Seiten jeder Lamellen ein.

Die Abbildung zeigt, wie die Kunststoffabdeckung (N) in die vorderste Lamelle eingesetzt wird.

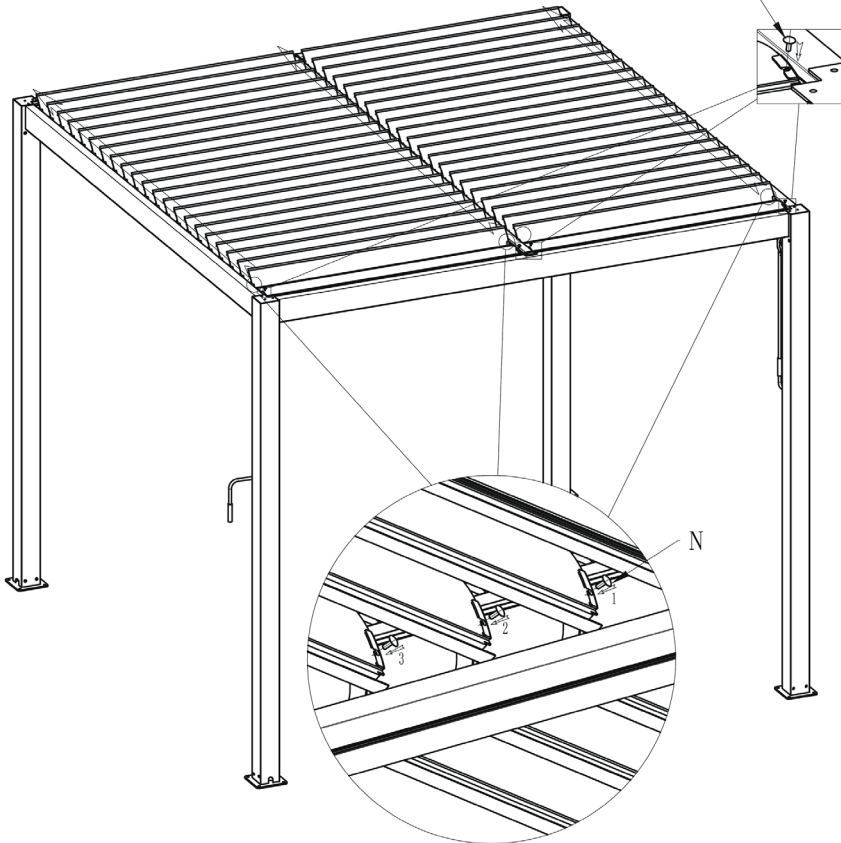
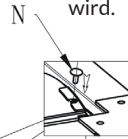

Drehen Sie die Lamellen in die Halbstellung und stecken Sie die Kunststoffabdeckungen (N) nacheinander in die Bohrung der beiden Enden jeder Lamelle.

Befestigen Sie zum Schluss die beiden Handkurbeln (J), zum Öffnen und Schließen der Lamellen drehen. Die Installation der Pergola ist jetzt abgeschlossen.

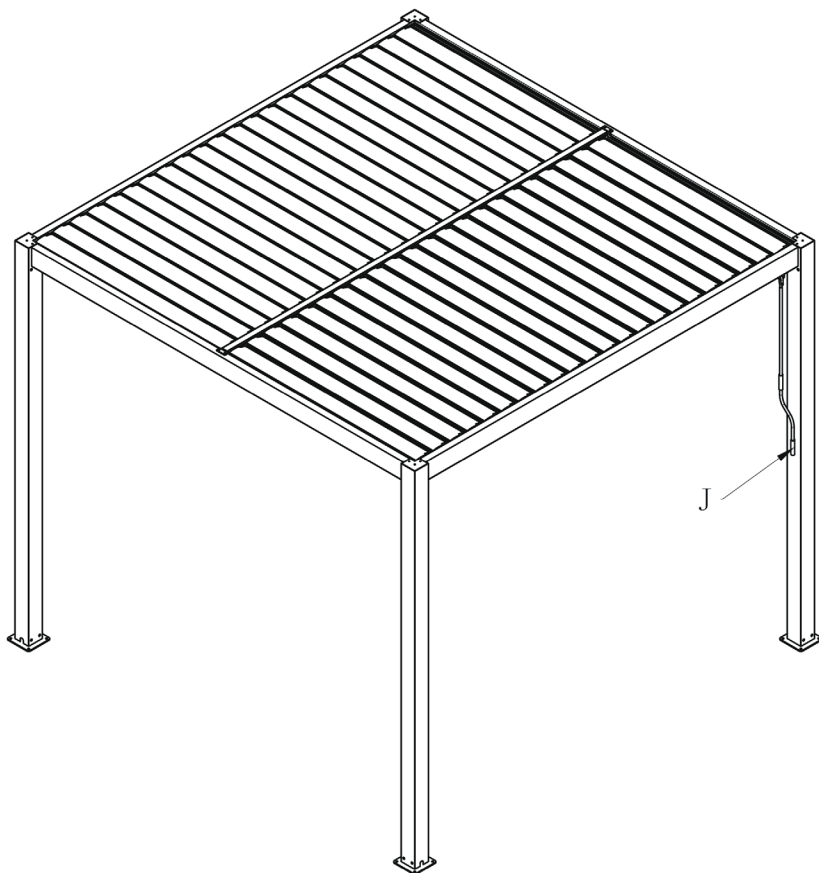

**Schritt 2:** Befestigen Sie das männliche Ende (M) des Balkens (B1) und das weibliche Ende (W) des Balkens (C) separat am Netzteil. Ziehen Sie dann die Schraubkappen am Ende der Lichtkabel fest.

**Schritt 1:** Verbinden Sie Ende (M) des Lichtkabels von Balken (B2) mit Ende (W) des Lichtkabels von Balken (C) und drehen Sie dann die Schraubkappe fest. Mit Ausnahme des Verbindungspunkts von Balken (B1) und (C) müssen die anderen Lichtkabel auf die gleiche Art im Uhrzeigersinn verbunden werden.

**Schritt 3:** Befestigen Sie das Netzteil mit den Schrauben (K5) am Balken (C). Stellen Sie die Lichtfarbe nach der Beleuchtung mit der Fernbedienung (P) ein.

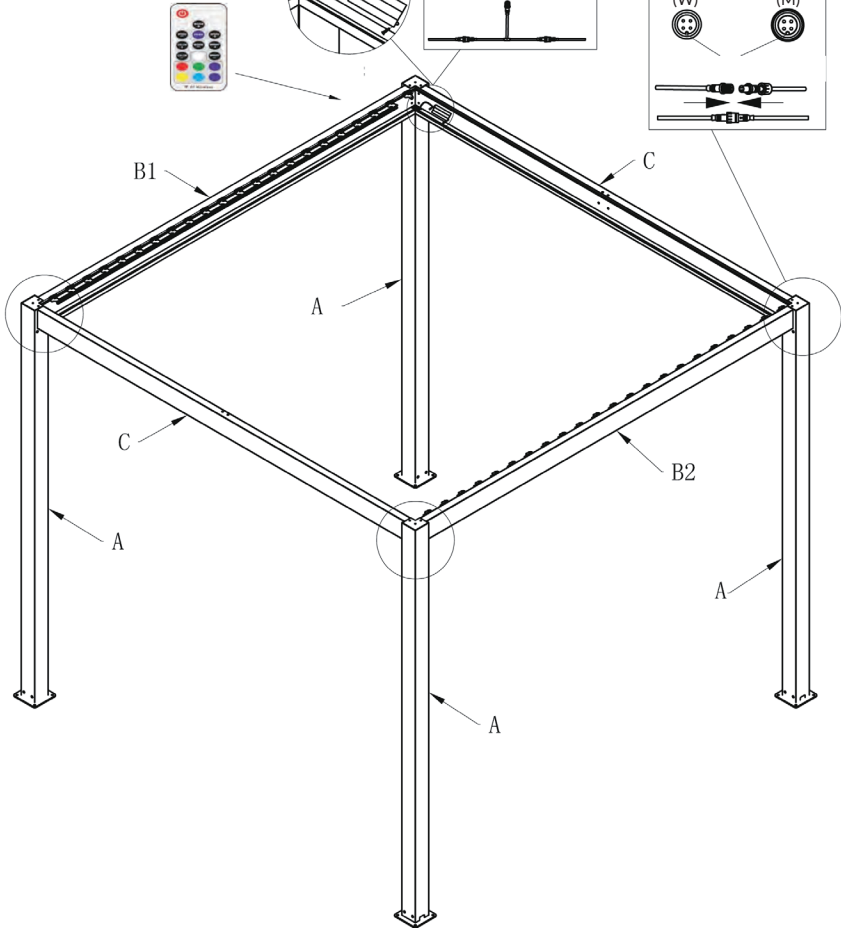
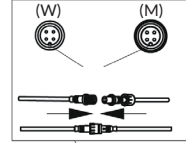
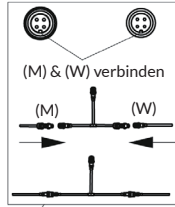

P



QTY: 1PCS

K 5



QTY: 2PCS

# INSTALLATION DES SOLARPANELS





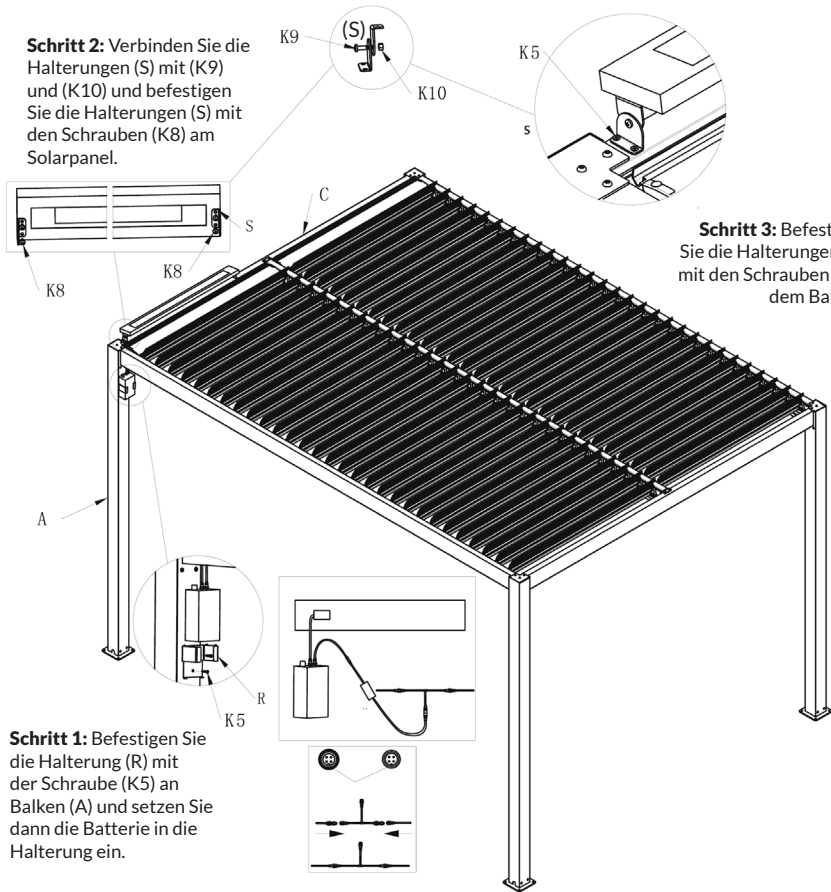

21

**Schritt 2:** Verbinden Sie die Halterungen (S) mit (K9) und (K10) und befestigen Sie die Halterungen (S) mit den Schrauben (K8) am Solarpanel.

**Schritt 3:** Befestigen Sie die Halterungen (S) mit den Schrauben (K5) dem Balken.



**Schritt 1:** Befestigen Sie die Halterung (R) mit der Schraube (K5) an Balken (A) und setzen Sie dann die Batterie in die Halterung ein.

R		QTY: 1PCS	K5		QTY: 6PCS	K8		QTY: 4PCS
S		QTY: 4PCS	K9		QTY: 2PCS	K10		QTY: 2PCS

# HINWEISE ZUM LITHIUM-IONEN-AKKU

## Spezifikation

Nennspannung	11,1 V
Nennleistung	10 Ah
Eingang	12,6 V / 3 A Max.
Ausgang	12 V (9 - 12,6 V) / 6 A Max.
Maße	158 x 90 x 60 mm (Gehäuse)
Gewicht	0,8 kg

## Geräteübersicht

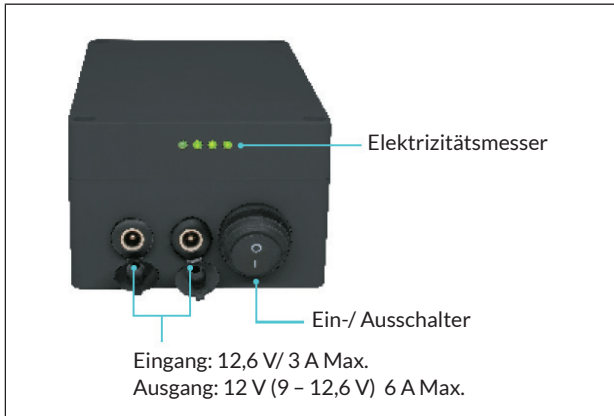

### Sicherheitshinweise

- Lassen Sie im Umgang mit dem Gerät äußerste Vorsicht walten und lassen Sie es nicht herunterfallen oder umkippen. Versuchen Sie keinesfalls, das Gerät auseinander zu bauen.
- Verwenden Sie das Gerät keinesfalls in feuchter Umgebung oder Wasser. Verwenden Sie das Gerät in trockener und gut belüfteter Umgebung.
- Dieses Produkt enthält eine Lithium-Ionen-Batterie. Halten Sie das Gerät fern von Feuerquellen.
- Wenn Sie das Gerät über einen längeren Zeitraum nicht verwenden, wird empfohlen, es dennoch alle 3 Monate zu laden, um die Lebensdauer der Batterie sicherzustellen.
- Laden Sie den Akku ausschließlich mit einem Ladekabel, welches den Anforderungen entspricht.
- Wenden Sie sich im Falle von Fehlfunktionen an den Hersteller oder den Kundendienst.

### Ladehinweise

1. Dieses Gerät darf ausschließlich mit dem vom Hersteller konfigurierten 12,6-V-Ladegerät verwendet werden und kann über den DC-Ladeanschluss geladen werden.
2. Verwenden Sie zum Laden des Akkus keine anderen Ladegeräte.
3. Wenn die Anzeileuchte des Geräts rot aufleuchtet, bedeutet dies, dass der Ladevorgang noch nicht abgeschlossen ist.
4. Die Kontrollleuchte des Ladegeräts leuchtet grün oder blau und zeigt damit den Abschluss des Ladevorgangs oder keine Ladung an. Bitte ziehen Sie den Stecker des Ladegeräts, nachdem es vollständig geladen ist, aus der Steckdose.
5. Leuchtet die Kontrollleuchte des Solarlademoduls rot und blinkt, zeigt dies an, dass keine Ladung stattfindet. Leuchtet die Kontrollleuchte orange, ist der Ladevorgang im Gange. Leuchtet die Kontrollleuchte grün, bedeutet dies, dass die Batterie vollständig geladen ist.



## BENUTZUNG DER FERNBEDIENUNG

### Funktionen

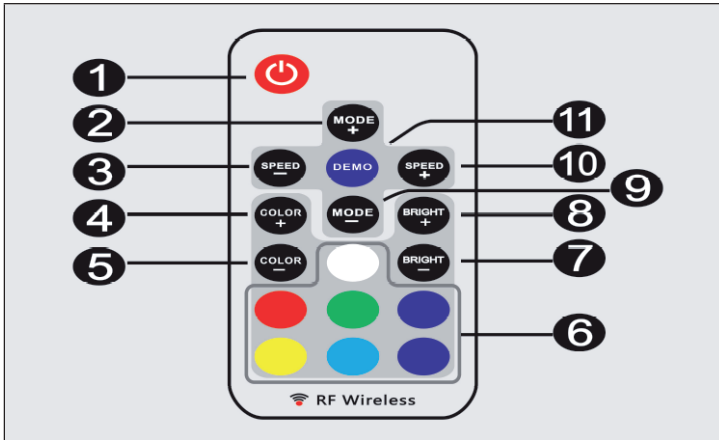

1	Ein/Standby Drücken Sie diese Taste, um das Gerät einzuschalten oder es in den Standby-Modus zu versetzen. Beim Einschalten wird der vorherige Status automatisch wiederhergestellt.
2/9	Dynamische Modusanpassung Durch Drücken dieser Taste, wechseln Sie entweder vom statischen Modus zum dynamischen Farbmodus oder Sie wechseln zwischen den dynamischen Modi.
3/10	Dynamische Geschwindigkeitsanpassung Durch Drücken der Taste SPEED+ kann die Geschwindigkeit erhöht und durch Drücken der Taste SPEED- kann die Geschwindigkeit gesenkt werden. Wenn diese Taste im statischen Modus gedrückt wird, wechselt das Gerät in den dynamischen Modus.
4/5	Statische Farbanpassung Durch Drücken dieser Taste, wechseln Sie entweder vom dynamischen Farbmodus zum statischen Modus oder Sie wechseln zwischen den statischen Farben.

6	Direkte Farbauswahl
	Mit dieser Taste gelangen Sie direkt in die statische Farbauswahl. Wenn Sie eine bestimmte Farbtaste drücken, leuchtet die LED in der entsprechenden Farbe auf. Die direkte Farbauswahl ist bei der Verwendung der Tasten COLOR+ und COLOR- enthalten.
7/8	Helligkeitsanpassung
	Helligkeitsanpassung der statischen Farben. Drücken Sie zum Erhöhen der Helligkeit die Taste BRIGHT+ und zum Senken der Helligkeit die Taste BRIGHT-. Das Gerät wechselt automatisch zum statischen Farbmodus, wenn diese Taste im dynamischen Modus gedrückt wird.
11	Demomodus
	Wenn Sie diese Taste drücken, gelangen Sie in den Demomodus. Im Demomodus werden 17 dynamische Modi in Dauerschleife abgespielt und jeder Modus wird drei Mal wiederholt.

---

## INSTALLATION DES LED-CONTROLLERS

---

### Stromversorgung

Für dieses Gerät kann eine Stromversorgung zwischen DC 5 V bis 24 V verwendet werden. Der Innenpol (oder das rote Kabel) der DC-Buchse ist positiv und die Hülse (oder das schwarze Kabel) ist negativ. Stellen Sie außerdem sicher, dass die Netzspannung mit der LED-Spannung übereinstimmt.

### LED Ausgang

Dieses Gerät unterstützt herkömmliche LED-Produkte mit Anodenverbindung. Die Markierung [▲] zeigt den gemeinsamen Anschlussknoten an.

Der Spitzenausgangsstrom beträgt 4 Ampere und der maximale Dauerstrom beträgt 2 Ampere pro Kanal. Bitte reduzieren Sie die Last, wenn das Hauptgerät überhitzt.

**Hinweis:** Die LED-Ausgänge dürfen nicht kurzgeschlossen oder überlastet werden. Dies kann zu dauerhaften Schäden führen!

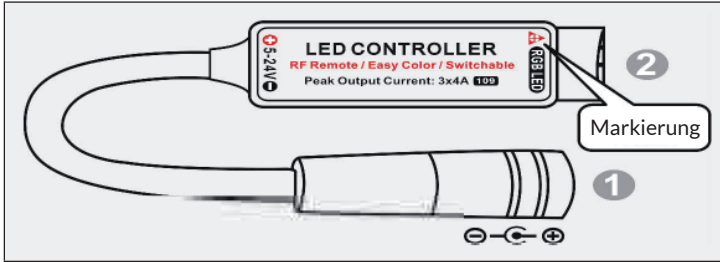

### Bedienung via Fernbedienung

Entfernen Sie vor der Benutzung das Batterie-Isolierband. Das drahtlose Fernbedienungssignal kann Barrieren durchdringen, daher ist es nicht notwendig, bei der Bedienung auf das Hauptgerät zu zielen. Um einen einwandfreien Empfang des Fernbedienungssignals zu gewährleisten, installieren Sie das Hauptgerät bitte nicht in einem geschlossenen Metallgehäuse.

### Neue Fernbedienung koppeln

Die Fernbedienung und die Haupteinheit sind standardmäßig gekoppelt. Darüber hinaus kann die Haupteinheit mit 3 weiteren Fernbedienungen gekoppelt werden. Bitte führen Sie folgende Schritte aus, um eine neue Fernbedienung zu koppeln:

1. Schalten Sie das Hauptgerät aus, ziehen Sie den Stecker und warten Sie 5 Sekunden lang. Stecken Sie den Stecker dann wieder ein und starten Sie das Hauptgerät.
2. Drücken Sie innerhalb von 5 Sekunden nach dem Einschalten gleichzeitig auf die Tasten [COLOR-] und [BRIGHT-].

Nach diesem Vorgang erkennt das Hauptgerät die neue Fernbedienung.

### **Freier Fernbedienungs-Koppelungsmodus**

In einigen speziellen Fällen muss das Hauptgerät mit beliebigen Fernbedienungen gekoppelt werden.

1. Schalten Sie das Hauptgerät aus, ziehen Sie den Stecker und warten Sie 5 Sekunden lang. Stecken Sie den Stecker dann wieder ein und starten Sie das Hauptgerät.
2. Drücken Sie innerhalb von 5 Sekunden nach dem Einschalten gleichzeitig auf die Tasten [EIN/STANDBY] und [MODE+].

Nach diesem Vorgang erkennt das Hauptgerät alle vorhandenen Fernbedienungen. Um das Hauptgerät mit einer bestimmten Fernbedienung zu koppeln, wiederholen Sie den Vorgang „Neue Fernbedienung koppeln“.

### **Reihenfolge der Ausgangsfarben schalten**

Die Standardreihenfolge der Ausgangsfarben des Controllers ist Grün-Rot-Blau. Falls die Farbtasten nicht mit der LED Farbe übereinstimmen, passen Sie die Reihenfolge der Ausgangsfarben wie folgt an:

1. Schalten Sie das Hauptgerät aus, ziehen Sie den Stecker und warten Sie 5 Sekunden lang. Stecken Sie den Stecker dann wieder ein und starten Sie das Hauptgerät.
2. Drücken Sie innerhalb von 5 Sekunden nach dem Einschalten gleichzeitig auf die Tasten [ROT] und [BLAU].

Mit diesem Vorgang schaltet die Ausgangssequenz zwischen 6 möglichen Kombinationen. Die 6 möglichen Kombinationen werden gespeichert und nach dem nächsten Aus- und Einschalten aktiviert.

## SPEZIELLE ENTSORGUNGSHINWEISE FÜR VERBRAUCHER IN DEUTSCHLAND

Entsorgen Sie Ihre Altgeräte fachgerecht. Dadurch wird gewährleistet, dass die Altgeräte umweltgerecht verwertet und negative Auswirkungen auf die Umwelt und menschliche Gesundheit vermieden werden. Bei der Entsorgung sind folgende Regeln zu beachten:

- Jeder Verbraucher ist gesetzlich verpflichtet, Elektro- und Elektronikaltgeräte (Altgeräte) sowie Batterien und Akkus getrennt vom Hausmüll zu entsorgen. Sie erkennen die entsprechenden Altgeräte durch folgendes Symbol der durchgestrichene Mülltonne (WEEE Symbol). 
- Sie haben Altbatterien und Altakkumulatoren, die nicht vom Altgerät umschlossen sind, sowie Lampen, die zerstörungsfrei aus dem Altgerät entnommen werden können, vor der Abgabe an einer Entsorgungsstelle vom Altgerät zerstörungsfrei zu trennen.
- Bestimmte Lampen und Leuchtmittel fallen ebenso unter das Elektro- und Elektronikgesetz und sind dementsprechend wie Altgeräte zu behandeln. Ausgenommen sind Glühbirnen und Halogenlampen. Entsorgen Sie Glühbirnen und Halogenlampen bitte über den Hausmüll, sofern Sie nicht das WEEE Symbol tragen.
- Jeder Verbraucher ist für das Löschen von personenbezogenen Daten auf dem Elektro- bzw. Elektronikgerät selbst verantwortlich.

### Rücknahmepflicht der Vertreiber

Vertreiber mit einer Verkaufsfläche für Elektro- und Elektronikgeräte von mindestens 400 Quadratmetern sowie Vertreiber von Lebensmitteln mit einer Gesamtverkauffläche von mindestens 800 Quadratmetern, die mehrmals im Kalenderjahr oder dauerhaft Elektro- und Elektronikgeräte anbieten und auf dem Markt bereitstellen, sind verpflichtet,

- 1 bei der Abgabe eines neuen Elektro- oder Elektronikgerätes an einen Endnutzer ein Altgerät des Endnutzers der gleichen Geräteart, das im Wesentlichen die gleichen Funktionen wie das neue Gerät erfüllt, am Ort der Abgabe oder in unmittelbarer Nähe hierzu unentgeltlich zurückzunehmen und
- 2 auf Verlangen des Endnutzers Altgeräte, die in keiner äußeren Abmessung größer als 25 Zentimeter sind, im Einzelhandelsgeschäft oder in unmittelbarer Nähe hierzu unentgeltlich zurückzunehmen; die Rücknahme darf nicht an den Kauf eines Elektro- oder Elektronikgerätes geknüpft werden und ist auf drei Altgeräte pro Geräteart beschränkt.

- Bei einem Vertrieb unter Verwendung von Fernkommunikationsmitteln ist die unentgeltliche Abholung am Ort der Abgabe auf Elektro- und Elektronikgeräte der Kategorien 1, 2 und 4 gemäß § 2 Abs. 1 ElektroG, nämlich „Wärmeüberträger“, „Bildschirmgeräte“ (Oberfläche von mehr als 100 cm<sup>2</sup>) oder „Großgeräte“ (letztere mit mindestens einer äußeren Abmessung über 50 Zentimeter) beschränkt. Für andere Elektro- und Elektronikgeräte (Kategorien 3, 5, 6) ist eine Rückgabemöglichkeit in zumutbarer Entfernung zum jeweiligen Endnutzer zu gewährleisten.
- Altgeräte dürfen kostenlos auf dem lokalen Wertstoffhof oder in folgenden Sammelstellen in Ihrer Nähe abgegeben werden: [www.take-e-back.de](http://www.take-e-back.de)
- Für Elektro- und Elektronikgeräte der Kategorien 1, 2 und 4 an bieten wir auch die Möglichkeit einer unentgeltlichen Abholung am Ort der Abgabe. Beim Kauf eines Neugeräts haben sie die Möglichkeit eine Altgerät abholung über die Webseite auszuwählen.
- Batterien können überall dort kostenfrei zurückgegeben werden, wo sie verkauft werden (z. B. Super-, Bau-, Drogeriemarkt). Auch Wertstoff- und Recyclinghöfe nehmen Batterien zurück. Sie können Batterien auch per Post an uns zurücksenden. Altbatterien in haushaltsüblichen Mengen können Sie direkt bei uns von Montag bis Freitag zwischen 07:30 und 15:30 Uhr unter der folgenden Adresse unentgeltlich zurückgeben:

**Chal-Tec GmbH**  
**Member of Berlin Brands Group**  
**Handwerkerstr. 11**  
**15366 Dahlwitz-Hoppegarten**  
**Deutschland**

- Wichtig zu beachten ist, dass Lithiumbatterien aus Sicherheitsgründen vor der Rückgabe gegen Kurzschluss gesichert werden müssen (z. B. durch Abkleben der Pole).
- Finden sich unter der durchgestrichenen Mülltonne auf der Batterie zusätzlich die Zeichen Cd, Hg oder Pb ist das ein Hinweis darauf, dass die Batterie gefährliche Schadstoffe enthält. (»Cd« steht für Cadmium, »Pb« für Blei und »Hg« für Quecksilber).

### **Hinweis zur Abfallvermeidung**

Indem Sie die Lebensdauer Ihrer Altgeräte verlängern, tragen Sie dazu bei, Ressourcen effizient zu nutzen und zusätzlichen Müll zu vermeiden. Die Lebensdauer Ihrer Altgeräte können Sie verlängern indem Sie defekte Altgeräte reparieren lassen. Wenn sich Ihr Altgerät in gutem Zustand befindet, könnten Sie es spenden, verschenken oder verkaufen.

---

## HINWEISE ZUR ENTSORGUNG

---



Wenn es in Ihrem Land eine gesetzliche Regelung zur Entsorgung von elektrischen und elektronischen Geräten gibt, weist dieses Symbol auf dem Produkt oder auf der Verpackung darauf hin, dass dieses Produkt nicht im Hausmüll entsorgt werden darf. Stattdessen muss es zu einer Sammelstelle für das Recycling von elektrischen und elektronischen Geräten gebracht werden. Durch regelkonforme Entsorgung schützen Sie die Umwelt und die Gesundheit Ihrer Mitmenschen vor negativen Konsequenzen. Informationen zum Recycling und zur Entsorgung dieses Produkts, erhalten Sie von Ihrer örtlichen Verwaltung oder Ihrem Hausmüllentsorgungsdienst.

Dieses Produkt enthält Batterien. Wenn es in Ihrem Land eine gesetzliche Regelung zur Entsorgung von Batterien gibt, dürfen die Batterien nicht im Hausmüll entsorgt werden. Informieren Sie sich über die örtlichen Bestimmungen zur Entsorgung von Batterien. Durch regelkonforme Entsorgung schützen Sie die Umwelt und die Gesundheit Ihrer Mitmenschen vor negativen Konsequenzen.

---

## HERSTELLER & IMPORTEUR (UK)

---

**Hersteller:**

Chal-Tec GmbH, Wallstraße 16, 10179 Berlin, Deutschland.

**Importeur für Großbritannien:**

Berlin Brands Group UK Ltd

PO Box 1145

Oxford, OX1 9UW

United Kingdom





**Dear Customer,**

Congratulations on purchasing this device. Please read the following instructions carefully and follow them to prevent possible damages. We assume no liability for damage caused by disregard of the instructions and improper use. Scan the QR code to get access to the latest user manual and more product information.



---

## CONTENTS

---

Individual Parts 38  
 Assembly 41  
 Installation of the solar panel 60  
 Notes on the Lithium-Ion Battery 61  
 Using the Remote Control 63  
 Installation of the LED Controller 64  
 Hints on Disposal 67  
 Manufacturer & Importer (UK) 67

















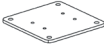
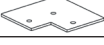

---







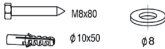

## TECHNICAL DATA

---

Item number	10035942 10035943	10035944 10035945
Dimensions	3x3 m	3x4 m

## INDIVIDUAL PARTS

No.	Description	Image	Pcs.
A	Column		4
B1	Beam (left)		1
B2	Beam (right)		1
C	Beam (front & back)		2
D	Middle beam		1
E	Slat		3x3=44 3x4=60
F	Column bottom plate		4
G	Column cover plate		4
H	Connecting piece for middle beam		2
I	Hinge ring		2
J	Hand crank		2
K1	Countersunk screw	 M6x16	40+2
K2	Flat head screw	 M6x16	20+2
K3	Washer	 D6x12	8+2
K4	Bolt & Nut	 M4x25	2
K5	Self-drilling screw	 ST4.2x25	8
K8	Screw	 ST4.8x10	4
K9	Screw	 M5x12	2
K10	Nut	 M5	2

No.	Description	Image	Pcs.
L	Wood screw, dowel and washer		16
M	Glass adhesive		1
N	Plastic cover		3x3=88 3x4=120
P	Remote control		1
Q	Drainage connection		4
R	Clamp		1
S	Bracket		4
T	Solar panel		1
H	Battery		1

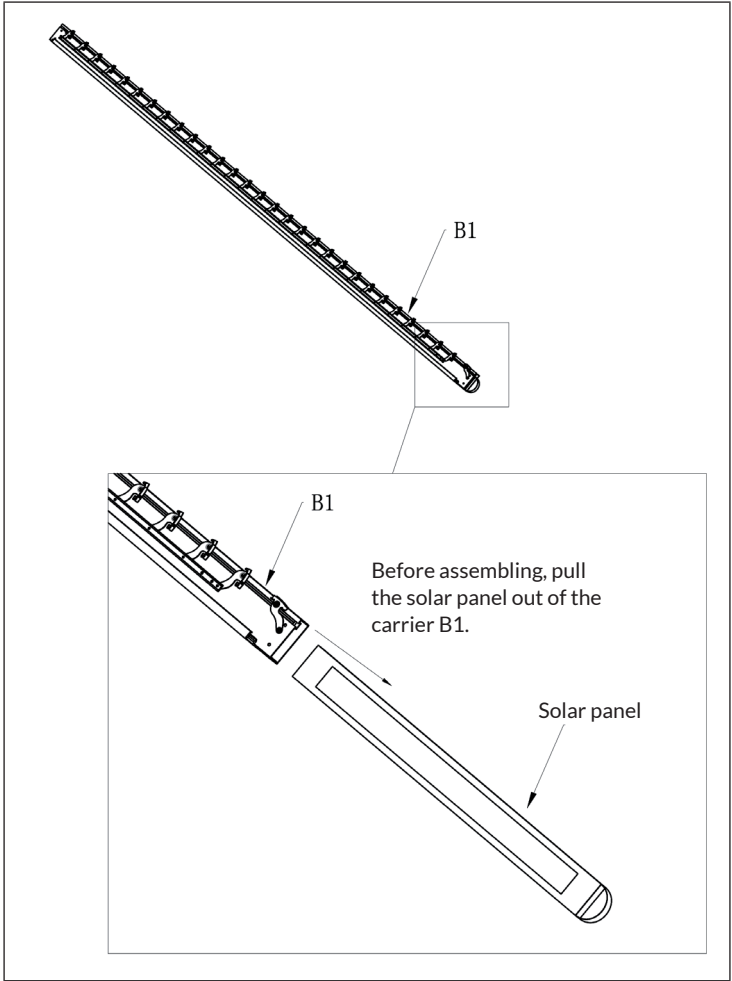

# ASSEMBLY

**Note** on the information in the pictures: QTY = quantity / PCS = pieces

1

## Connect the drainage connection to the column.

Clamp the drainage connection (Q) into the column slot. Then connect the base plate to the column (A) and tighten the screws. Perform these steps for all 4 columns.

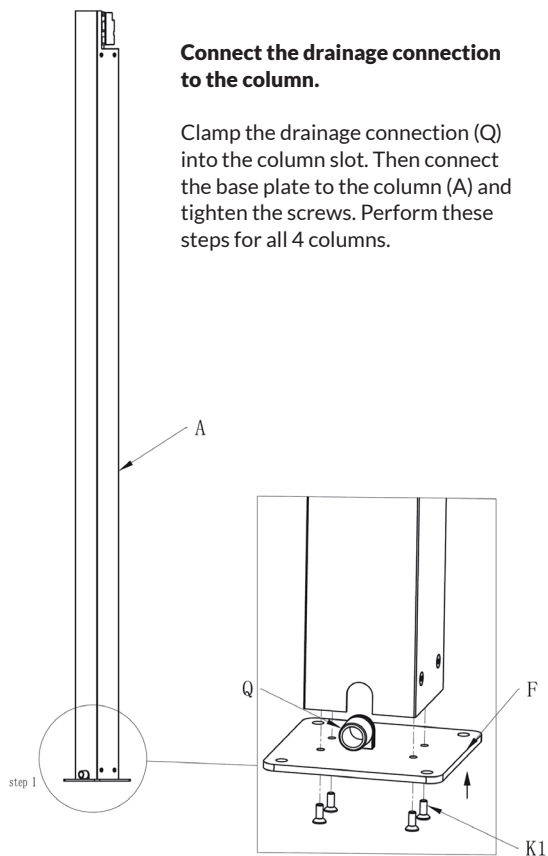

K1  QTY: 16PCS

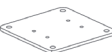
F  QTY: 4PCS

Q  QTY: 4PCS

Fit the connector (H) to one side of the middle beam (D). Then tighten the screw (K1). Perform the same steps on the other side of the beam.

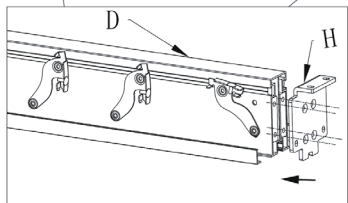
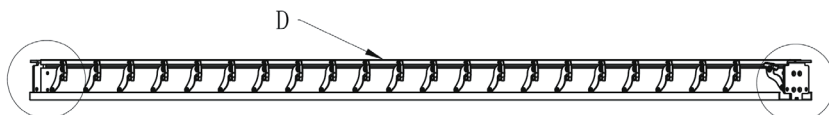

**Step 1**

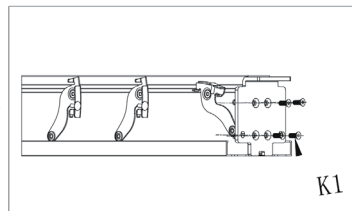

**Step 2**

K1

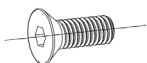

QTY:8PCS

H

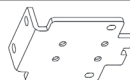

QTY:2PCS

3

Insert the two hinge rings (I) into the drive shaft on the beam (D) and fasten the hinge rings with one screw and one nut (K4) each.

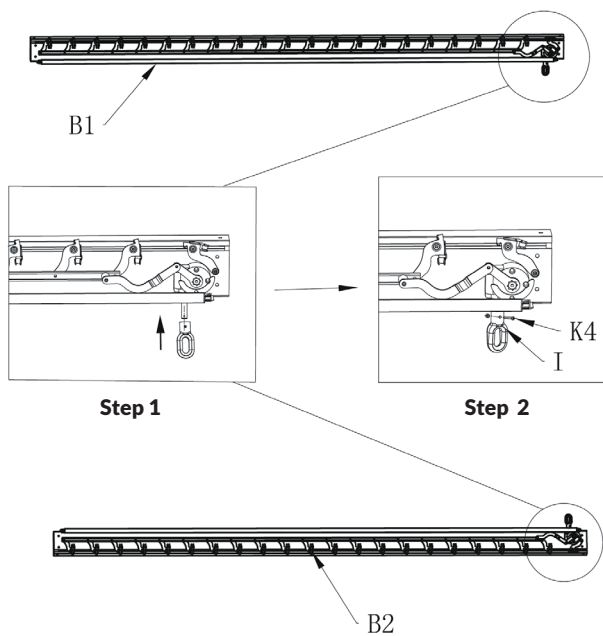

I

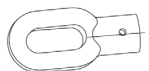

QTY:2PCS

K4

M4

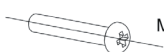

M4x25

QTY:2 SETS

Place the columns and the beam as shown in the figure, making sure that the drain connection of the columns always faces the same side.

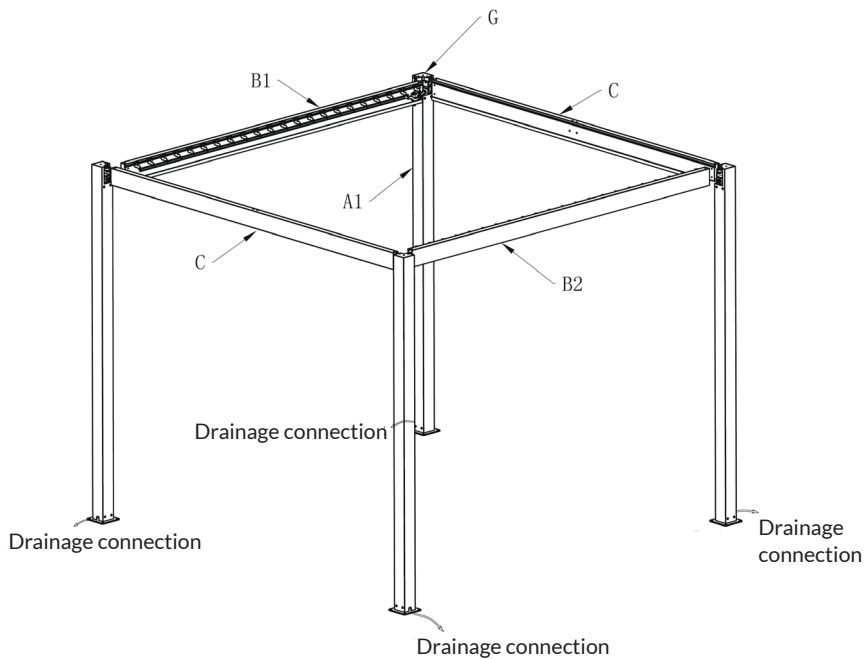



5

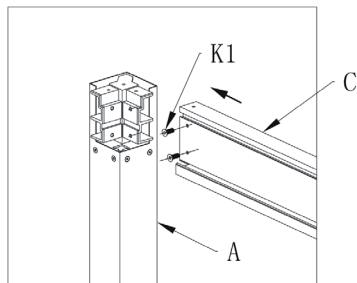

Place the two ends of the front and rear beam (C) respectively on the corner connectors on the column and tighten the screws (K1).

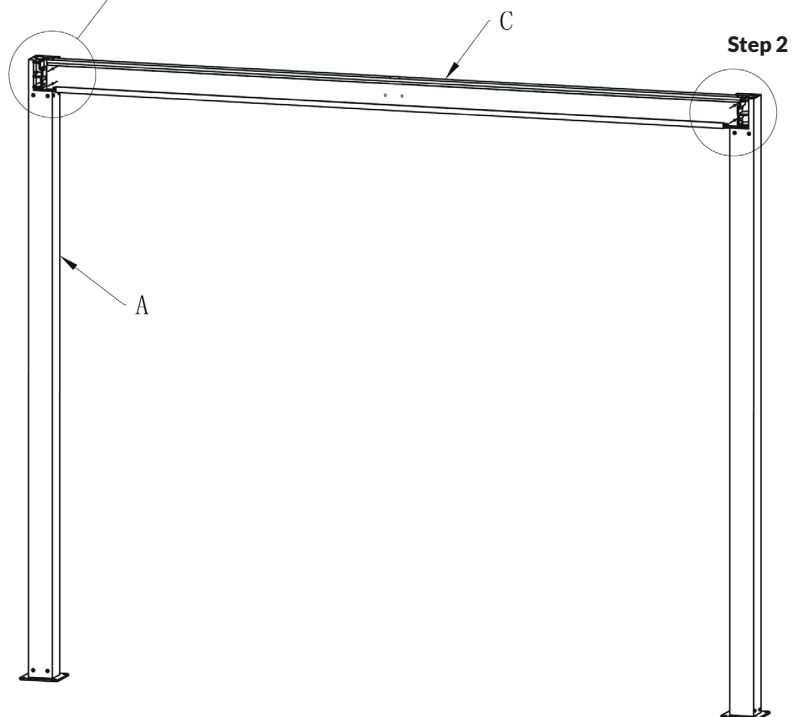
**Step 1**

K1

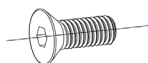

QTY:4PCS

Place the left and right beam (B1&B2) respectively on the corner connectors on the columns and fasten the beams with screws (K1).

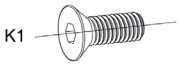
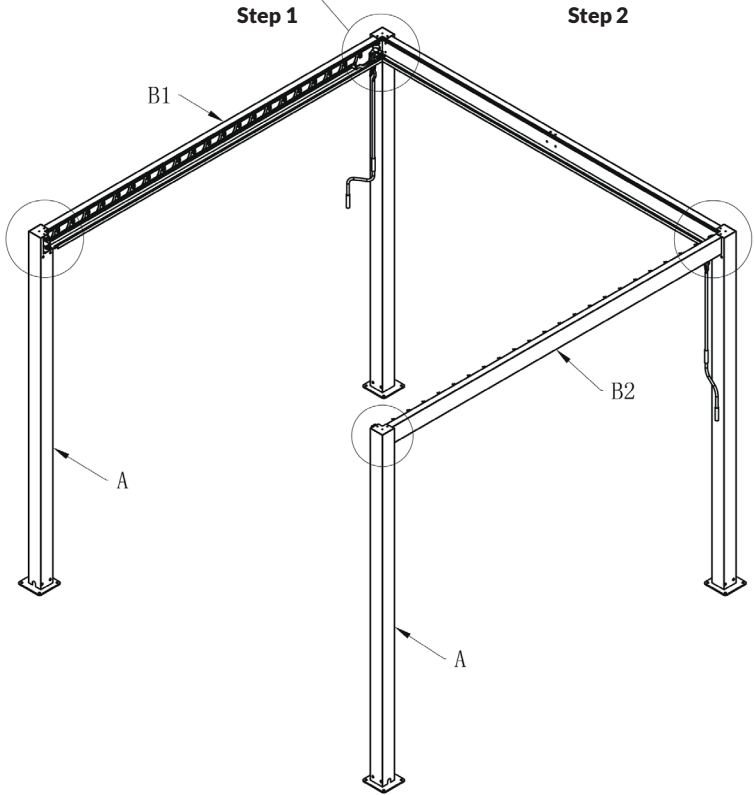
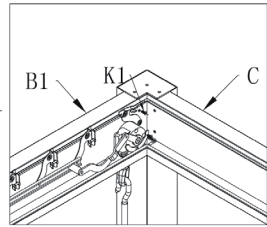
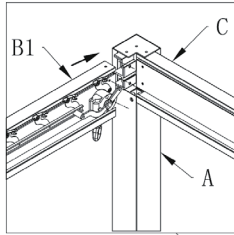

QTY:8PCS

7

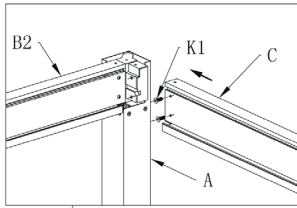

Place the beam (C) on the corner connectors on the columns and also fasten the beam with screws (K1).

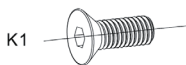
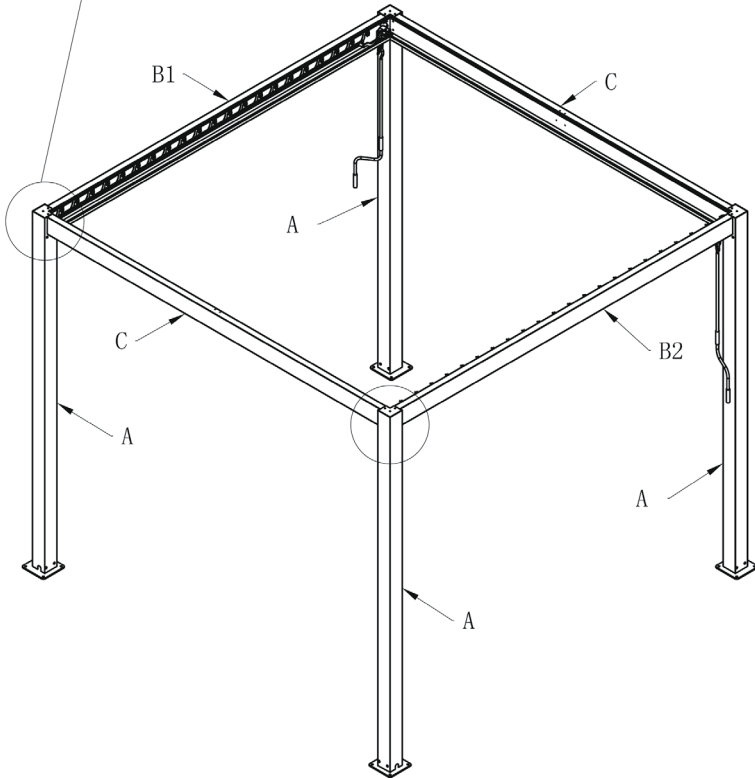

QTY:4PCS

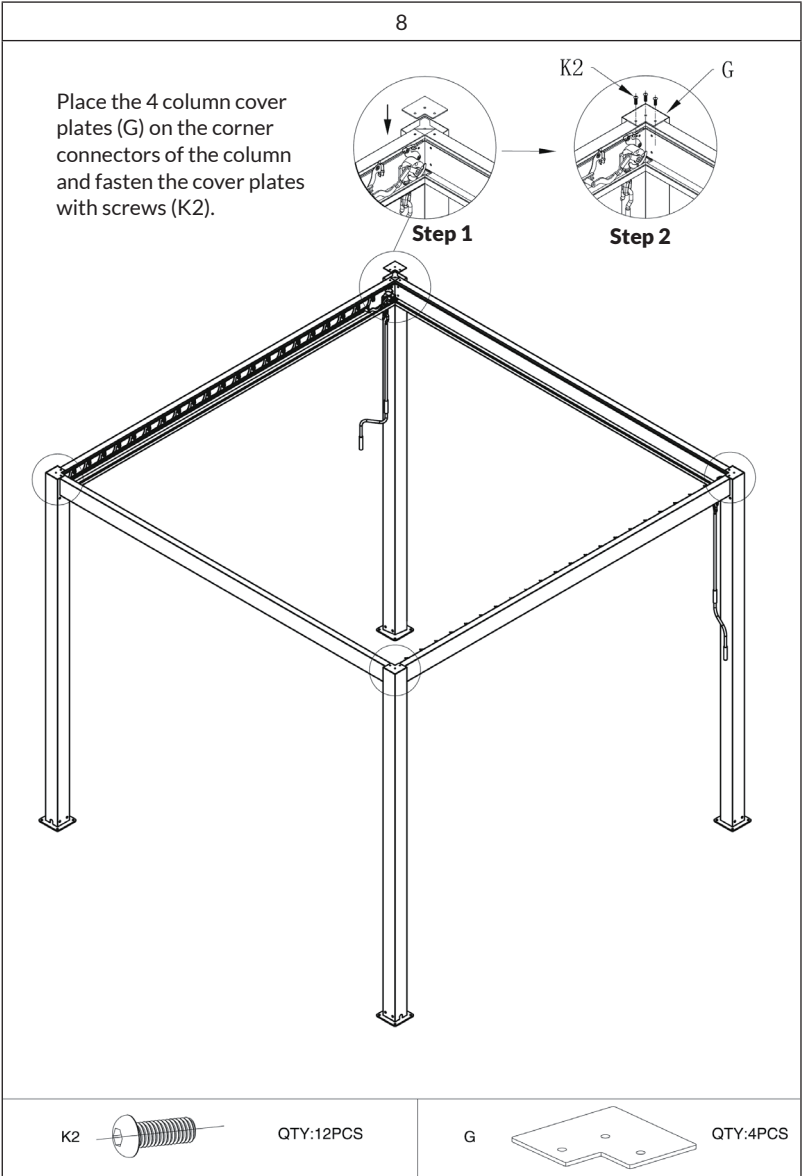

9

Place the four columns so that they are perpendicular to the floor. The distance between the hems should be exactly the same at the top and bottom of each. Then use a marking pen to mark 16 holes on the floor, which should correspond to the holes in the base plate.

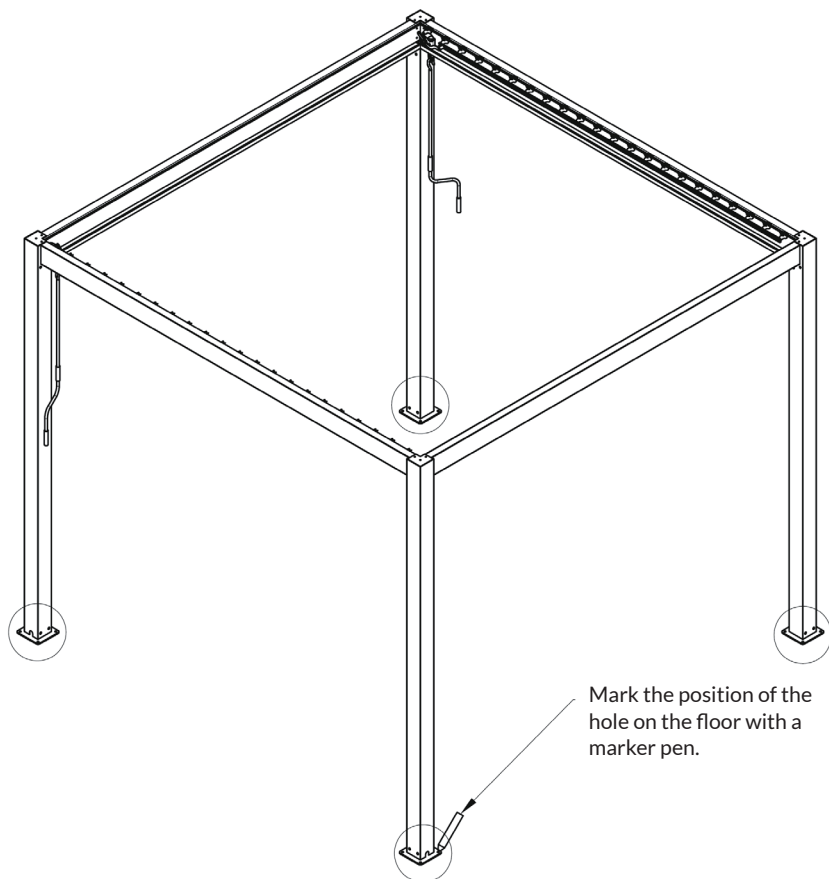

10

Remove the rod from the marking and drill holes with the diameter of 10 mm and depth of 80 mm with a percussion drill at the 16 marking positions on the floor.

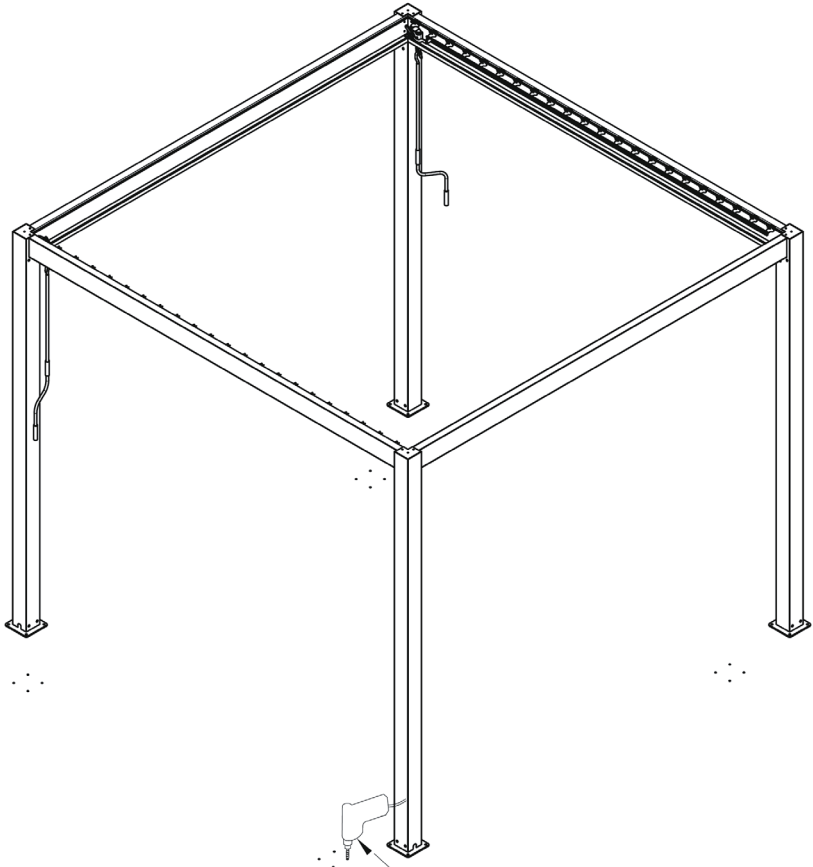

Drill a total of 16 holes with a diameter of 10 mm and a depth of 80 mm.

11

Insert the dowels into the drilled holes in the floor. Place the framework on the drilled holes and align the holes of the column base plates with the drilled holes on the floor. Then fasten each column base plate with 4 washers (K6) and 4 screws (L).

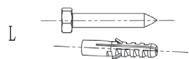
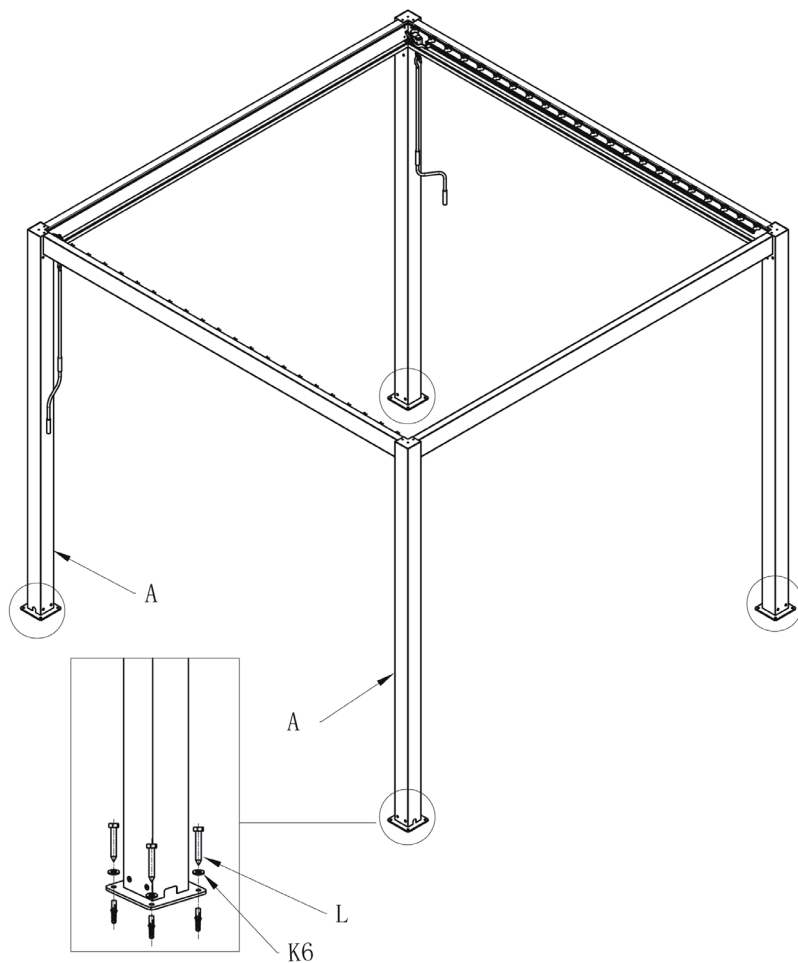

QTY: 16PCS

12

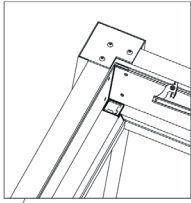

Spread the glass adhesive (M) evenly around the drain of the column and the joints of the beams (see enlarged Bild).

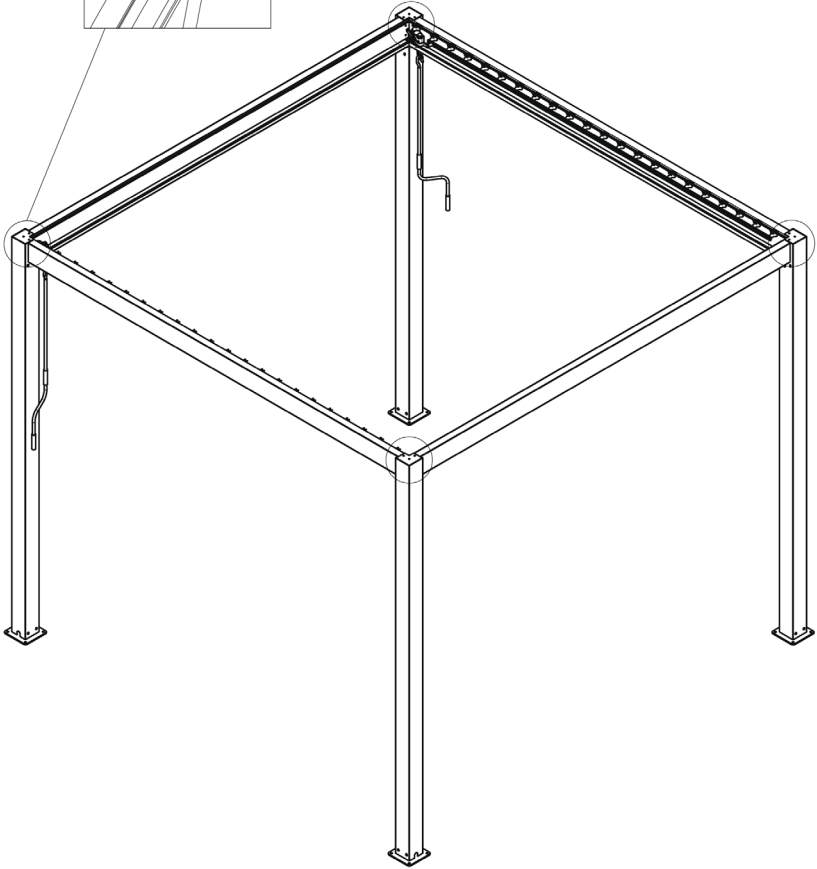

M



QTY: 1PC



13

Place the middle bar (D) on the front and rear bars (C).

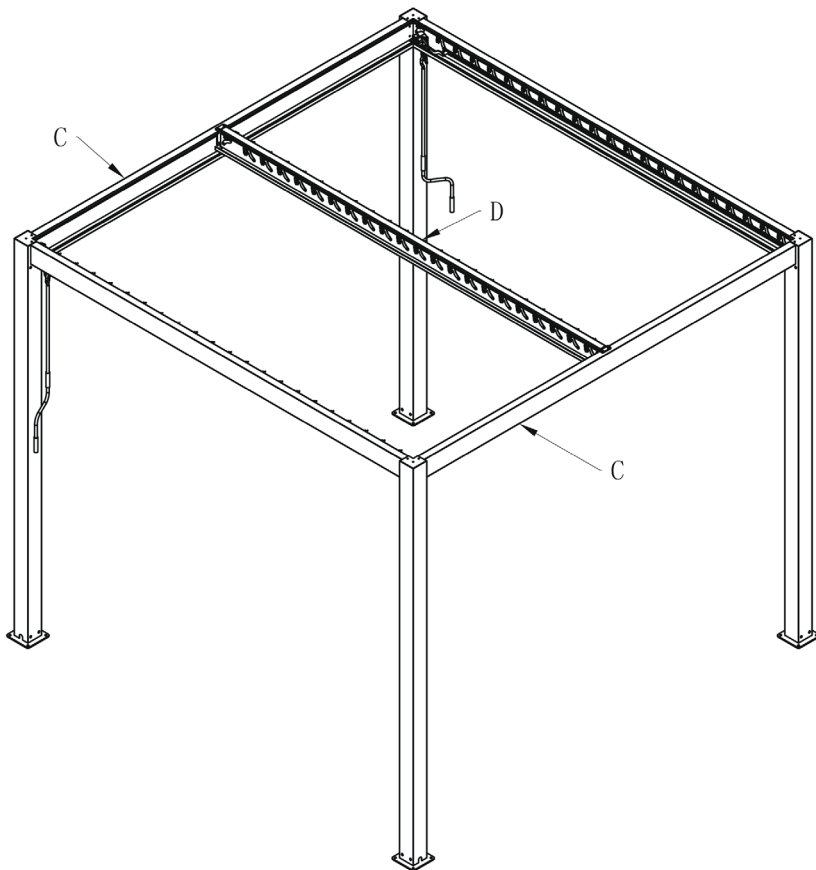

Insert 6 of the slats (E) at the end of the brackets on either side of the beams (B1 & B2) and push down to secure.

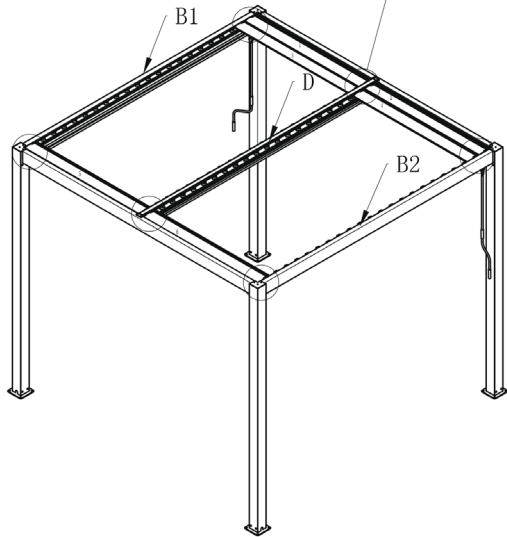
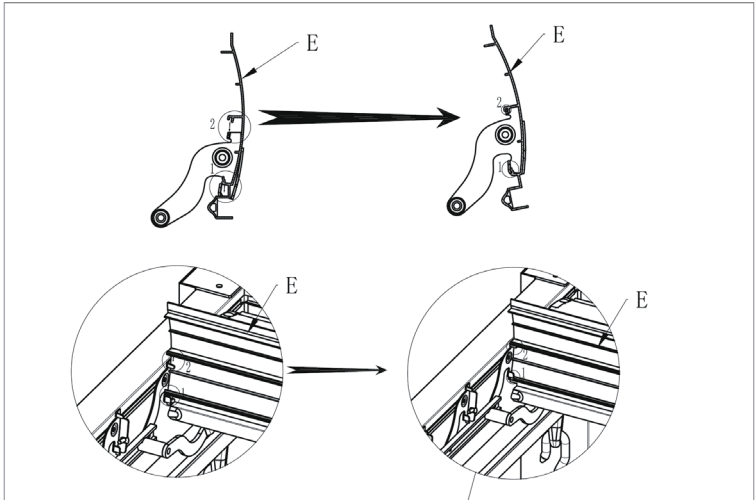

15

First fasten the screw (K2) with the washer (K3) in the hole under the beam (D). Repeat this step for beam (C). Then insert the other slats one after the other.

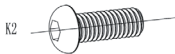
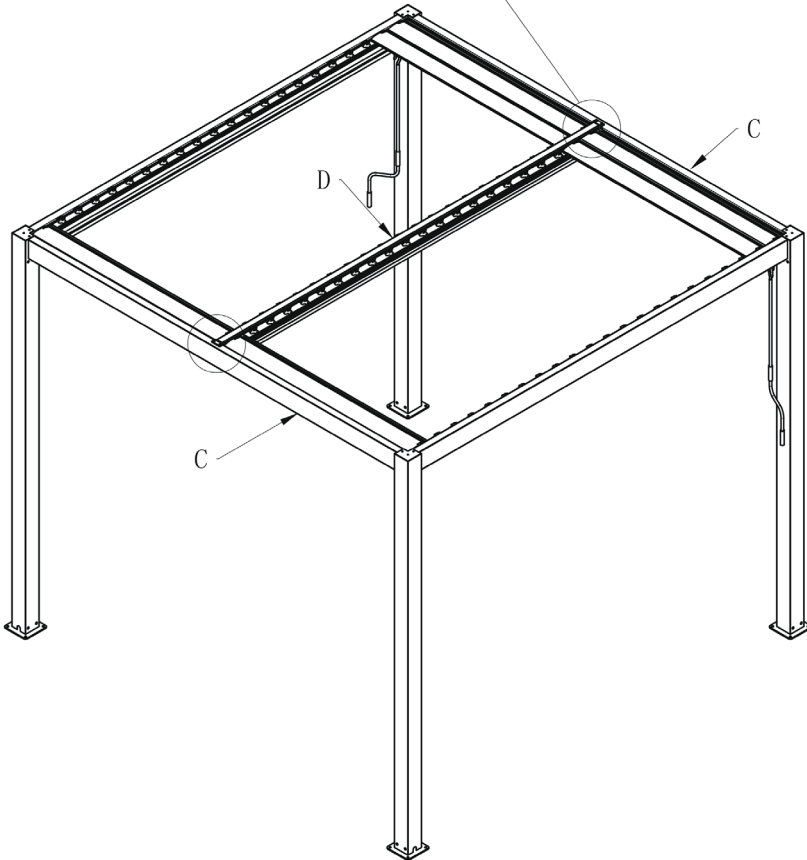
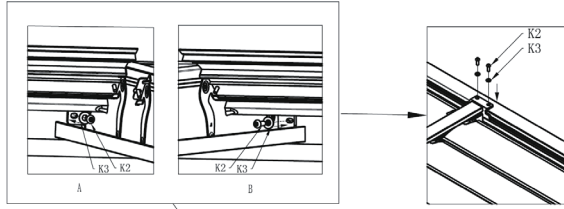

QTY: 8PCS



QTY: 8PCS

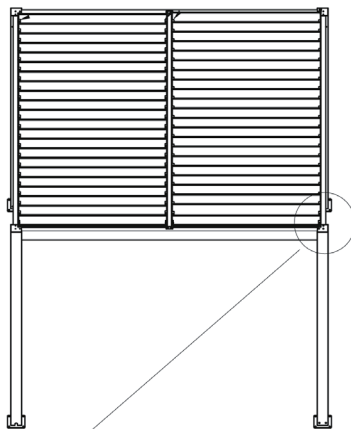

Adjust the pergola according to the following steps if it does not close completely.

A: Hole of the slat  
B: Hole of the slat support

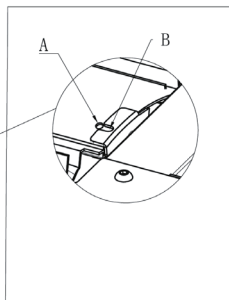
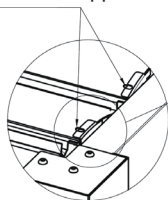

Adjust the installation as follows if hole A and hole B are not properly aligned:

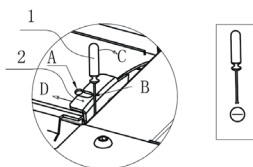

Adjust the slat support (B) with a straight screwdriver.

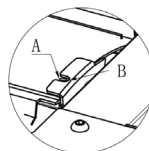

Hole A and B should be on top of each other after adjustment.

Insert the plastic cover (N) on both sides of each slat.

The figure shows how to insert the plastic cover (N) into the foremost slat.

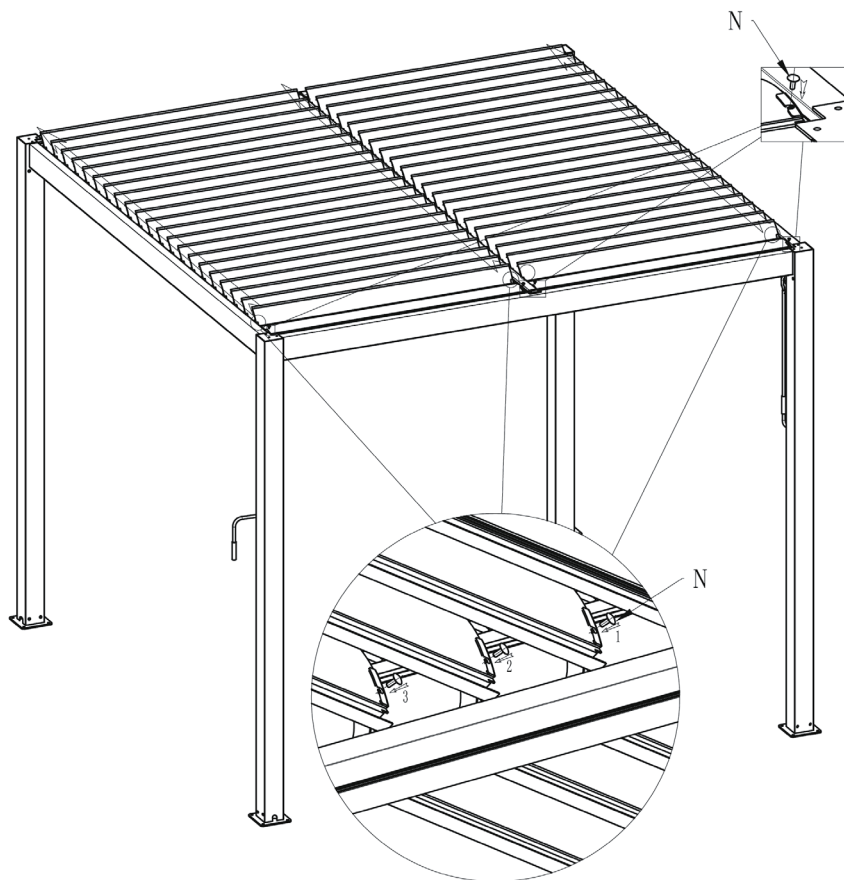

Turn the slats to the half position and insert the plastic covers (N) one after the other into the hole of both ends of each slat.

Finally, attach the two hand cranks (J), turn to open and close the slats. The installation of the pergola is now complete.

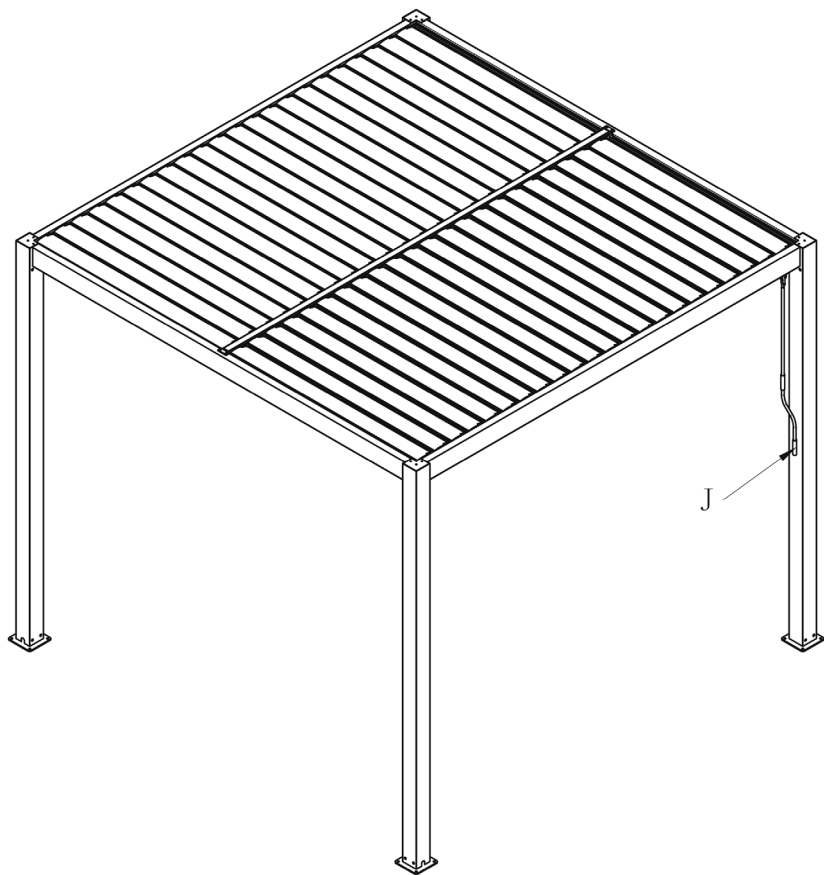

**Step 2:** Attach the male end (M) of the bar (B1) and the female end (W) of the bar (C) to the power supply separately. Then tighten the screw caps on the end of the light cables.

**Step 1:** Connect end (M) of the light cable of beam (B2) with end (W) of the light cable of beam (C) and then tighten the screw cap. Except for the connection point of beam (B1) and (C), the other light cables must be connected in the same clockwise way.

**Step 3:** Attach the power supply to the beam (C) with the screws (K5). Adjust the light color according to the illumination with the remote control (P).

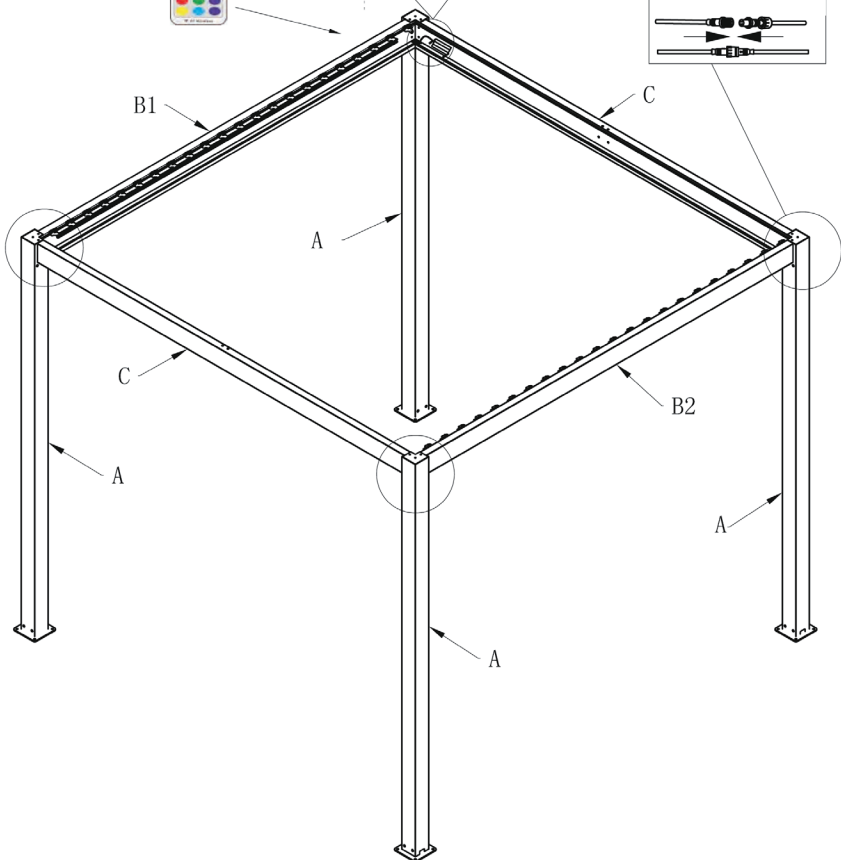
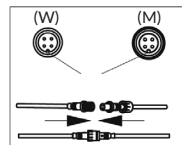
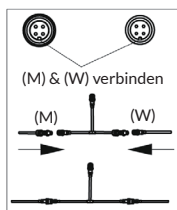
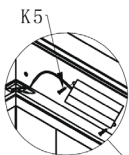

P



QTY: 1PCS

K 5



QTY: 2PCS

# INSTALLATION OF THE SOLAR PANEL

21



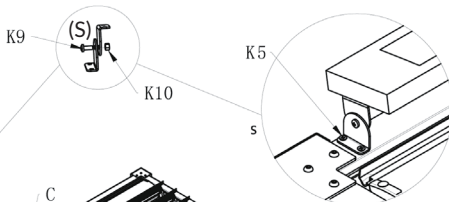

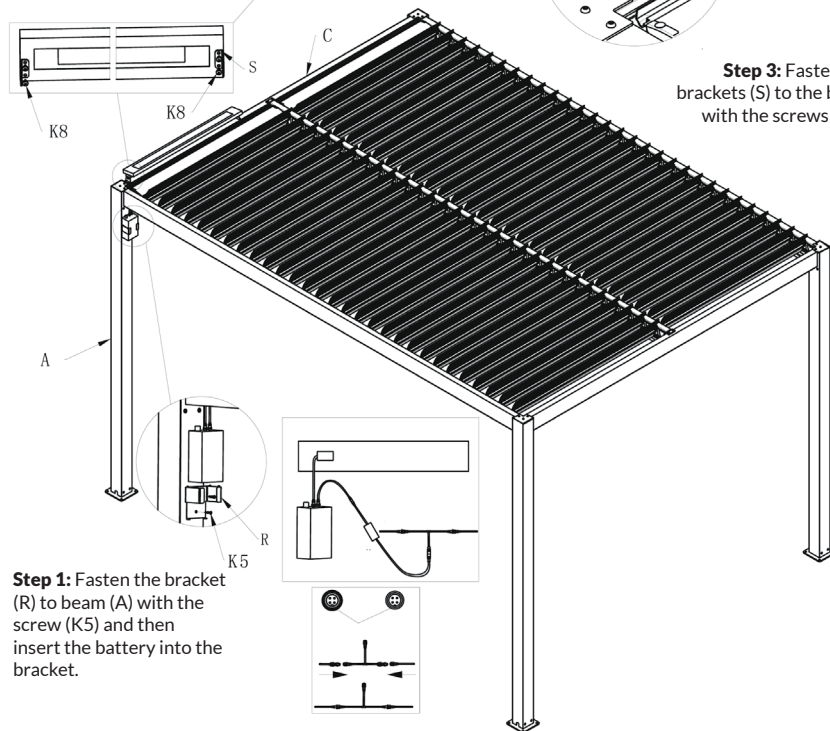

**Step 2:** Connect the brackets (S) with (K9) and (K10) and fix the brackets (S) to the solar panel with the screws (K8).



**Step 3:** Fasten the brackets (S) to the beam with the screws (K5).



**Step 1:** Fasten the bracket (R) to beam (A) with the screw (K5) and then insert the battery into the bracket.

R		QTY: 1PCS	K5		QTY: 6PCS	K8		QTY: 4PCS
S		QTY: 4PCS	K9		QTY: 2PCS	K10		QTY: 2PCS



## NOTES ON THE LITHIUM-ION BATTERY

### Specification

Rated voltage	11,1 V
Rated power	10 Ah
Input	12,6 V / 3 A Max.
Output	12 V (9 - 12,6 V) / 6 A Max.
Dimensions	158 x 90 x 60 mm (Housing)
Weight	0,8 kg

### Device Overview

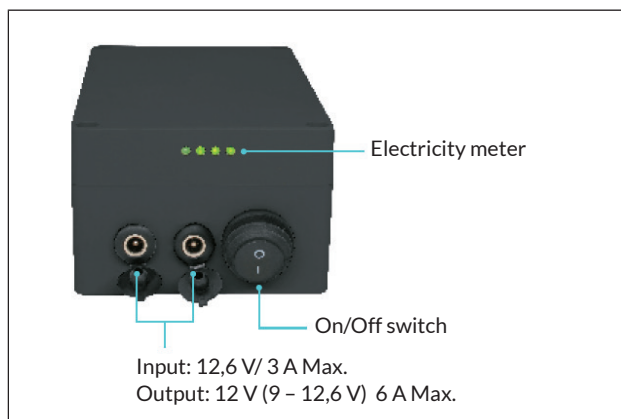

### **Safety Instructions**

- Exercise extreme caution when handling the unit and do not allow it to fall or tip over. Never attempt to disassemble the device.
- Never use the device in a damp environment or water. Use the device in a dry and well-ventilated environment.
- This product contains a lithium-ion battery. Keep the device away from fire sources.
- If you do not use the device for a long period of time, it is recommended that you still charge it every 3 months to ensure battery life.
- Charge the battery only with a charging cable that meets the requirements.
- In case of malfunction, contact the manufacturer or customer service.

### **Charging Instructions**

1. This device must only be used with the 12.6 V charger configured by the manufacturer and can be charged via the dc charging port.
2. Do not use other chargers to charge the battery.
3. If the indicator light of the device lights up red, it means that charging is not yet complete.
4. The indicator light of the charger lights up green or blue, indicating the completion of charging or no charging. Please unplug the charger from the power outlet after it is fully charged.
5. If the solar charging module indicator light is red and flashing, it indicates that there is no charging. If the indicator light is orange, charging is in progress. If the control light is green, it means that the battery is fully charged.

## USING THE REMOTE CONTROL

### Functions

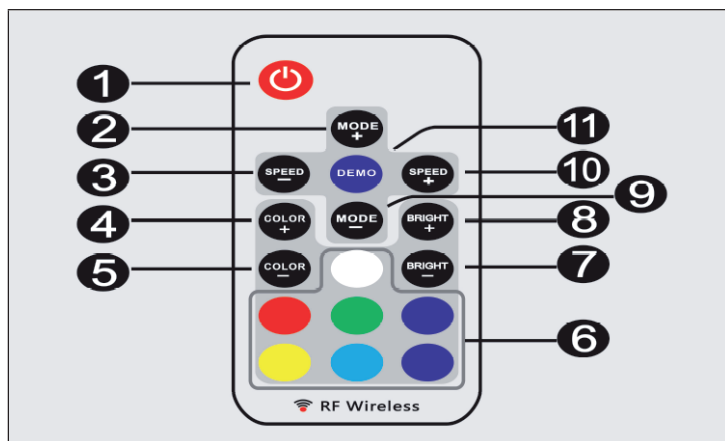

1	On/Standby
	Press this key to switch the device on or put it into standby mode. When the power is turned on, the previous status is automatically restored.
2/9	Dynamic mode adjustment
	Press this key to either switch from static mode to dynamic color mode, or to switch between dynamic modes.
3/10	Dynamic speed adjustment
	Pressing the SPEED+ key increases the speed and pressing the SPEED- key decreases the speed. When this key is pressed in static mode, the device switches to dynamic mode.
4/5	Static color adjustment
	By pressing this key, you either switch from dynamic color mode to static mode or you switch between static colors.

6	Direct color selection
	This key takes you directly to the static color selection. When you press a specific color key, the LED lights up in the corresponding color. Direct color selection is included when using the COLOR+ and COLOR- keys.
7/8	Brightness adjustment
	Brightness adjustment of static colors. Press the BRIGHT+ key to increase the brightness and the BRIGHT- key to decrease the brightness. The device automatically switches to static color mode when this key is pressed in dynamic mode.
11	Demo mode
	When you press this key, you enter the demo mode. In demo mode, 17 dynamic modes are played in continuous loop and each mode is repeated three times.

---

## INSTALLATION OF THE LED CONTROLLER

---

### Power supply

A power supply between DC 5 V to 24 V can be used for this device. The inner pole (or red wire) of the DC socket is positive and the sleeve (or black wire) is negative. Also, make sure that the line voltage matches the LED voltage.

### LED Output

This unit supports conventional LED products with anode connection. The [▲] mark indicates the common connection node.

The peak output current is 4 amps and the maximum continuous current is 2 amps per channel. Please reduce the load when the main unit overheats.

**Note:** Do not short circuit or overload the LED outputs. This may cause permanent damage!

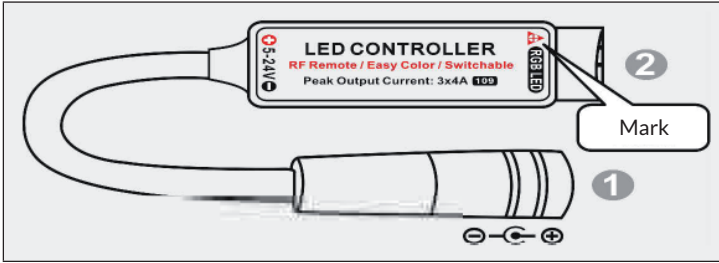

### Operation via remote control

Remove the battery insulating tape before use. The wireless remote control signal can penetrate barriers, so it is not necessary to aim at the main unit during operation. To ensure proper reception of the remote control signal, please do not install the main unit in a closed metal enclosure.

### Pairing a new remote control

The remote control and the main unit are paired by default. In addition, the main unit can be paired with 3 other remote controls. Please follow the steps below to pair a new remote control. 1:

1. Turn off the main unit, unplug it and wait for 5 seconds. Then plug it back in and start the main unit.
2. Press the [color-] and [bright-] buttons simultaneously within 5 seconds after power on.

After this operation, the main unit will recognize the new remote control.

### **Free remote control pairing mode**

In some special cases, the main unit needs to be paired with any remote controls.

1. Turn off the main unit, unplug it and wait for 5 seconds. Then plug the connector back in and start the main unit.
2. Press the [ON/STANDBY] and [MODE+] buttons simultaneously within 5 seconds after power on.

After this procedure, the main unit will recognize all existing remote controls. To pair the main unit with a specific remote control, repeat the „Pairing a new remote control“ procedure.

### **Switching the order of output colors**

The default order of the controller output colors is green-red-blue. If the color buttons do not match the LED color, adjust the output color order as follows:

1. Turn off the main unit, unplug it and wait for 5 seconds. Then plug the connector back in and start the main unit.
2. Press the [red] and [blue] buttons simultaneously within 5 seconds after power on.

With this operation, the output sequence switches between 6 possible combinations. The 6 possible combinations are stored and activated after the next power off and on.

---

## HINTS ON DISPOSAL

---



If there is a legal regulation for the disposal of electrical and electronic devices in your country, this symbol on the product or on the packaging indicates that this product must not be disposed of with household waste. Instead, it must be taken to a collection point for the recycling of electrical and electronic equipment. By disposing of it in accordance with the rules, you are protecting the environment and the health of your fellow human beings from negative consequences. For information about the recycling and disposal of this product, please contact your local authority or your household waste disposal service.

This product contains batteries. If there is a legal regulation for the disposal of batteries in your country, the batteries must not be disposed of with household waste. Find out about local regulations for disposing of batteries. By disposing of them in accordance with the rules, you are protecting the environment and the health of your fellow human beings from negative consequences.

---

## MANUFACTURER & IMPORTER (UK)

---

**Manufacturer:**

Chal-Tec GmbH, Wallstrasse 16, 10179 Berlin, Germany.

**Importer for Great Britain:**

Berlin Brands Group UK Ltd  
PO Box 1145  
Oxford, OX1 9UW  
United Kingdom





**Chère cliente, cher client,**

Toutes nos félicitations pour l'acquisition de ce nouvel appareil. Veuillez lire attentivement et respecter les instructions de ce mode d'emploi afin d'éviter d'éventuels dommages. Nous ne saurions être tenus pour responsables des dommages dus au non-respect des consignes et à la mauvaise utilisation de l'appareil. Scannez le QR-Code pour obtenir la dernière version du mode d'emploi ainsi que d'autres informations concernant le produit :



---

## SOMMAIRE

---

Pièces Détachées	70
Assemblage	73
Installation Du Panneau Solaire	92
Remarques sur les batteries Lithium ion	93
Utilisation de la télécommande	95
Installation du contrôleur LED	96
Informations sur le recyclage	99
Fabricant et importateur (UK)	99

















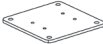

---









## FICHE TECHNIQUE

---

Numéro d'article	10035942 10035943	10035944 10035945
Dimensions	3x3 m	3x4 m

## PIÈCES DÉTACHÉES

N°	Description	Photo	Nombre
A	Pilier		4
B1	Poutre (gauche)		1
B2	Poutre (droite)		1
C	Poutre (avant & arrière)		2
D	Poutre du milieu		1
E	Lamelle		3x3=44 3x4=60
F	Platine de pilier		4
G	Platine couvrante de pilier		4
H	Raccord pour la poutre du milieu		2
I	Anneau de charnière		2
J	Manivelle		2
K1	Vis à tête fraisée	 M6x16	40+2
K2	Vis à tête plate	 M6x16	20+2
K3	Rondelle	 D6x12	8+2
K4	Vis & écrou	 M4x25	2
K5	Vis auto taraudeuse	 ST4.2x25	8
K8	Vis	 ST4.8x10	4
K9	Vis	 M5x12	2
K10	Écrou	 M5	2

No.	Description	Photo	Nombre
L	Vis à bois, cheville et rondelle		16
M	Colle à verre		1
N	Cache en plastique		3x3=88 3x4=120
P	Télécommande		1
Q	Raccord de drainage		4
R	Patte de fixation		1
S	Support		4
T	Panneau solaire		1
H	Batterie		1

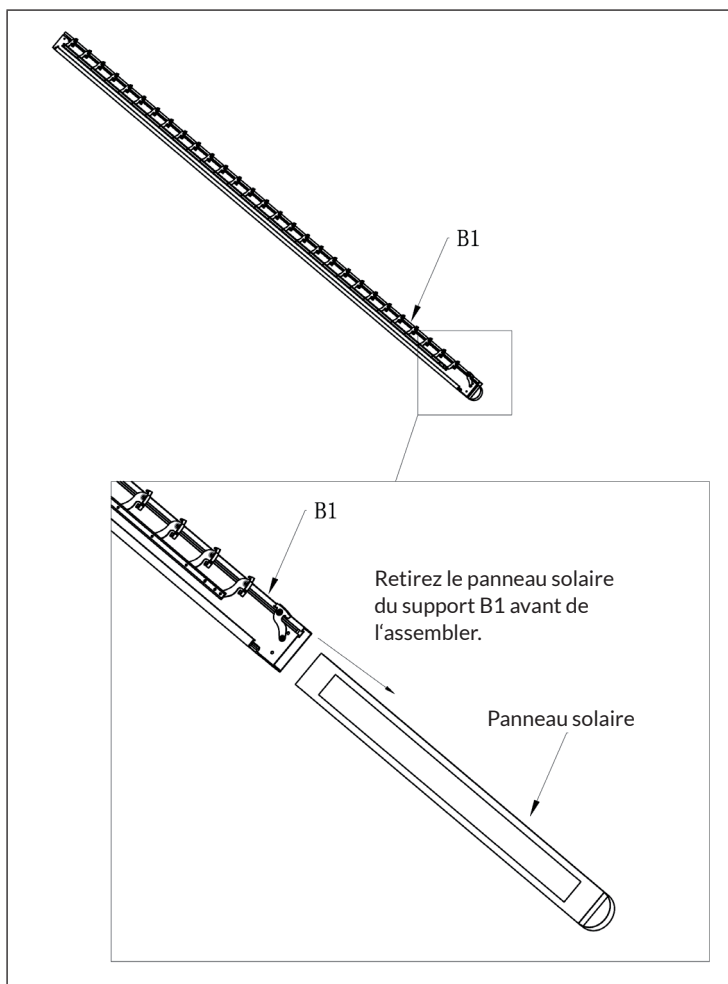

# ASSEMBLAGE

Remarque sur les données dans les images : QTY = quantité / PCS = nombre

1

## Connexion du raccordement de drainage à la pilier

Fixez le connecteur de drainage (Q) dans la fente de la pilier. Ensuite, connectez la platine de base à la pilier (A) et serrez les vis. Effectuez ces étapes pour les 4 piliers.

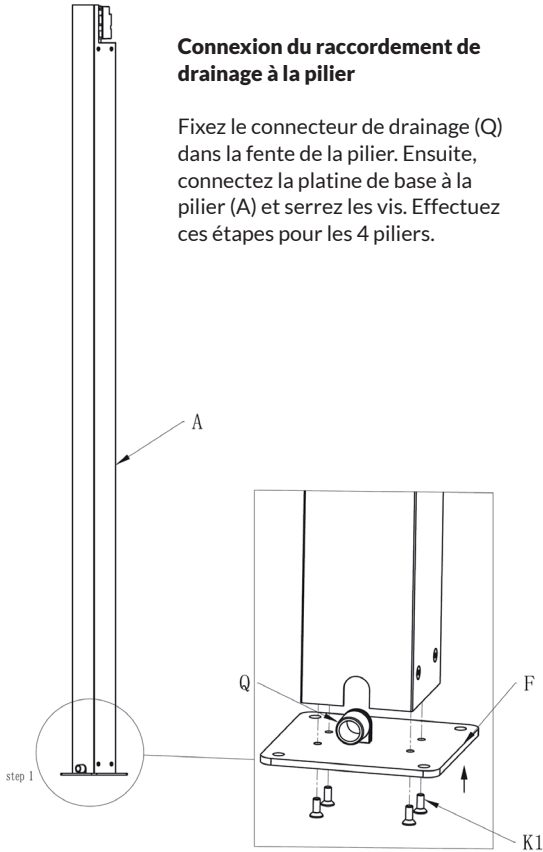

K1  QTY: 16PCS

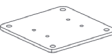
F  QTY: 4PCS

Q  QTY: 4PCS

Ajustez le connecteur (H) sur un côté de la poutre centrale (D). Serrez ensuite la vis (K1). Faites de même de l'autre côté de la poutre.

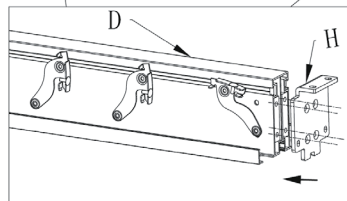
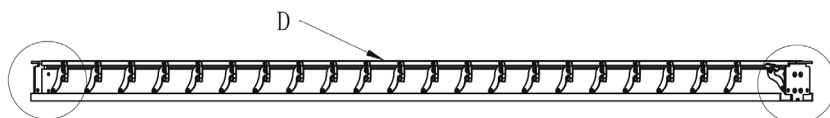

Étape 1

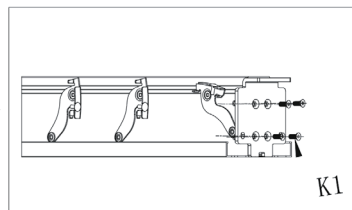

Étape 2

K1

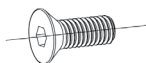

QTY:8PCS

H

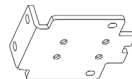

QTY:2PCS

3

Insérez les deux anneaux de charnière (I) dans l'arbre d'entraînement sur la poutre (D) et fixez les anneaux de charnière avec chaque vis et un écrou (K4).

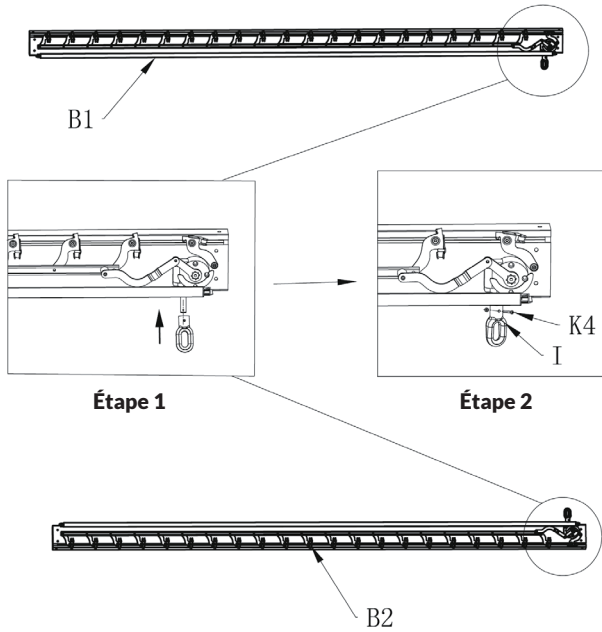

I

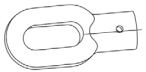

QTY:2PCS

K4

M4

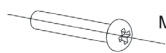

M4x25

QTY:2 SETS

Placez les piliers et la poutre comme indiqué sur l'illustration et assurez-vous que la connexion de drainage des piliers pointe toujours du même côté.

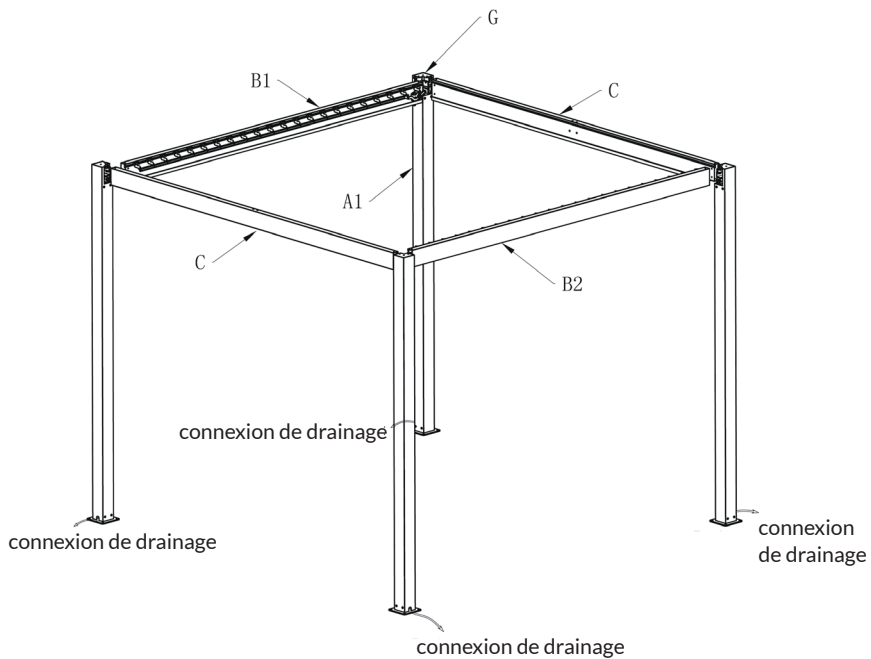



5

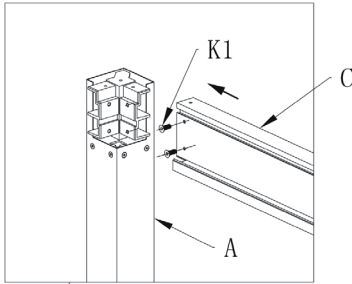

Placez les deux extrémités de la poutre avant et arrière (C) sur les connecteurs d'angle de la poutre et serrez les vis (K1).

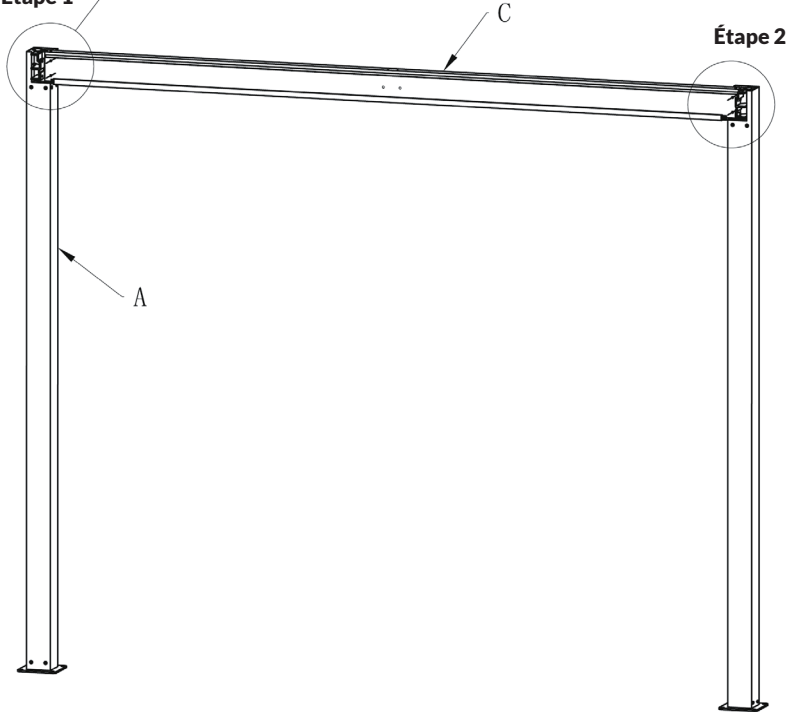
**Étape 1****Étape 2**

K1

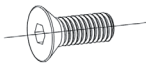

QTY:4PCS

6

Placez les poutres de gauche et de droite (B1 et B2) sur les connecteurs d'angle sur les piliers et fixez les poutres avec des vis (K1).

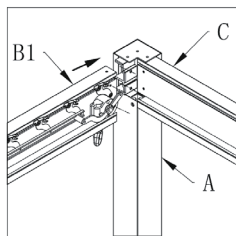

Étape 1

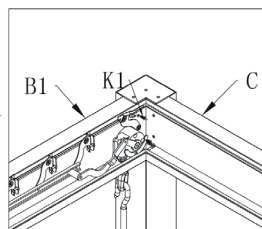

Étape 2

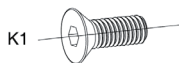
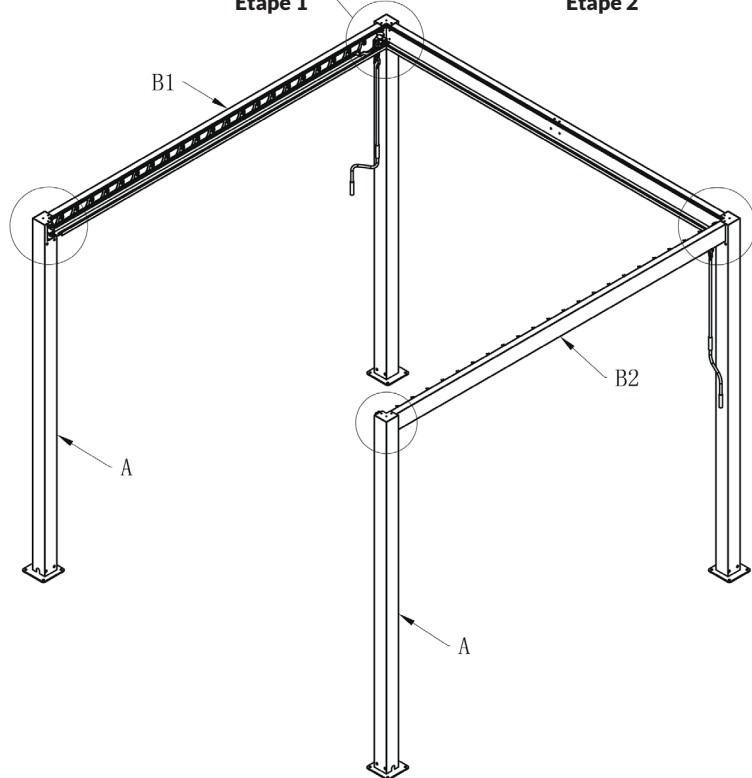

K1

QTY:8PCS

7

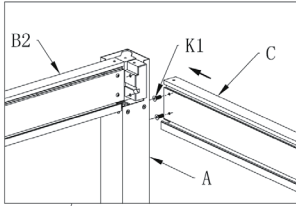

Placez la poutre (C) sur les connecteurs d'angle sur les piliers et fixez également la poutre avec des vis (K1).

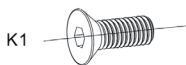
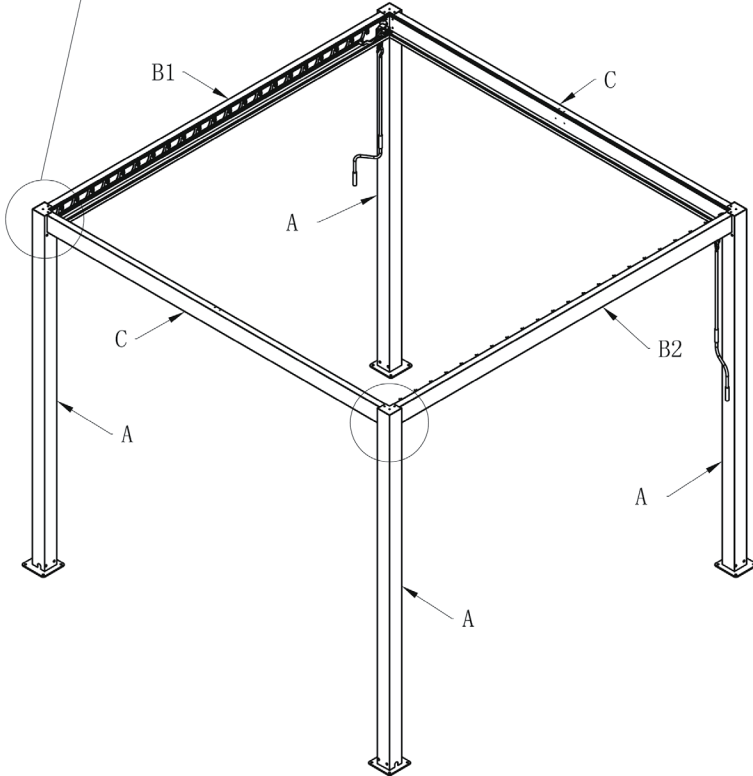

QTY:4PCS

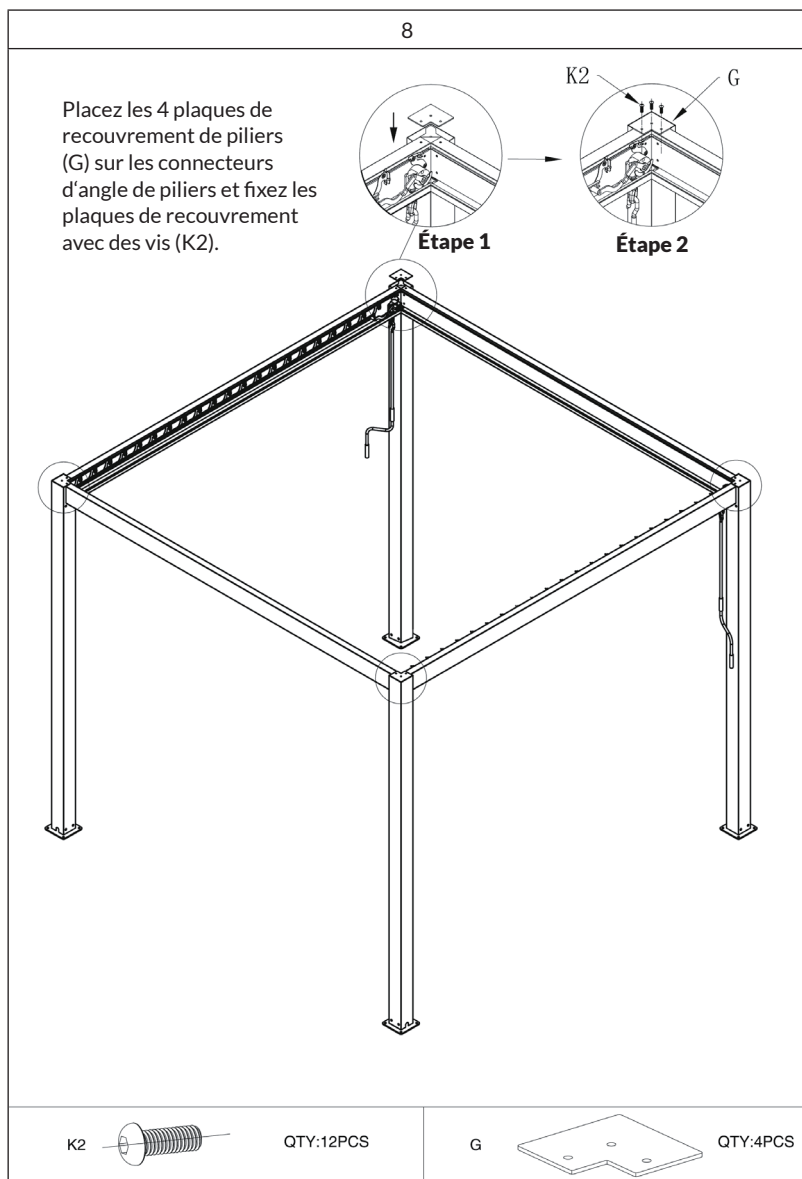

9

Installez les quatre piliers perpendiculairement au sol. La distance entre les piliers doit être exactement la même en haut et en bas. Ensuite, utilisez un marqueur pour marquer 16 trous sur le sol correspondant aux trous de la platine de base.

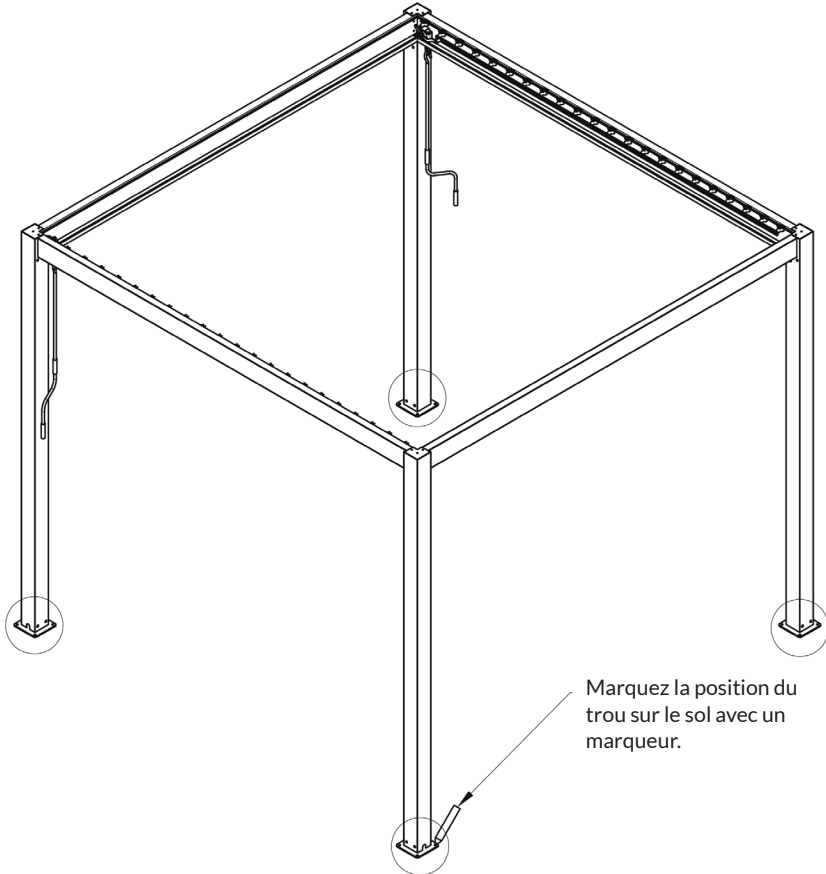

10

Retirez la structure du marquage et utilisez un perforateur pour percer des trous d'un diamètre de 10 mm et d'une profondeur de 80 mm aux 16 positions de marquage sur le sol.

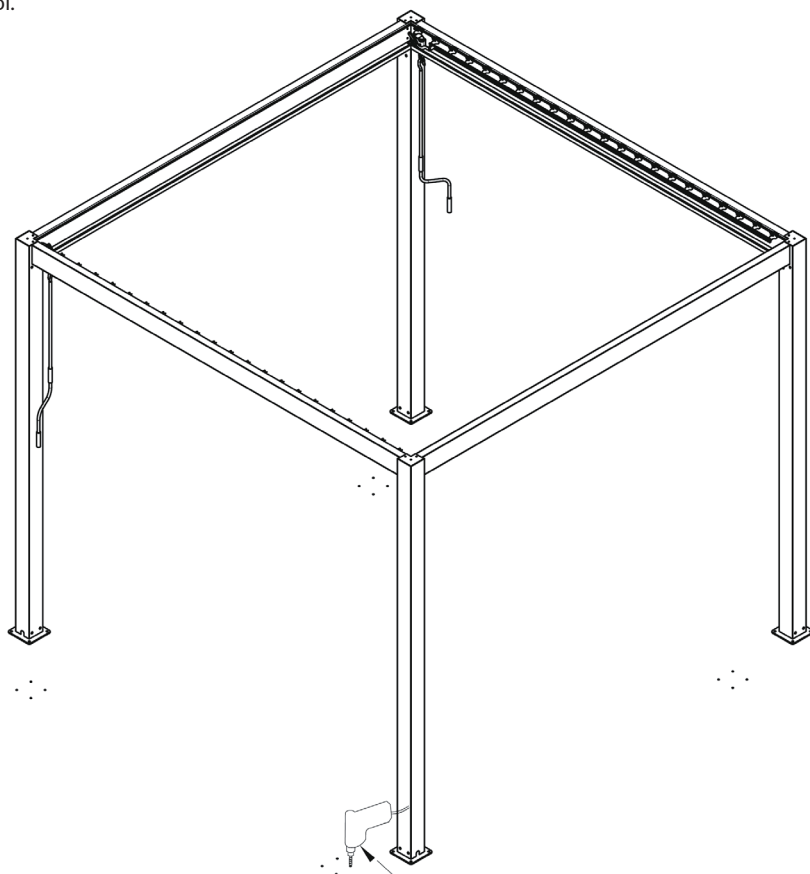

Percez au total 16 trous d'un diamètre de 10 mm et d'une profondeur de 80 mm.

11

Insérez les chevilles dans les trous percés au sol. Placez la structure sur les trous percés et alignez les trous des platines de fixation du pilier avec les trous dans le sol. Fixez ensuite les platines des piliers avec 4 rondelles (K6) et 4 vis (L).

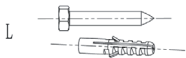
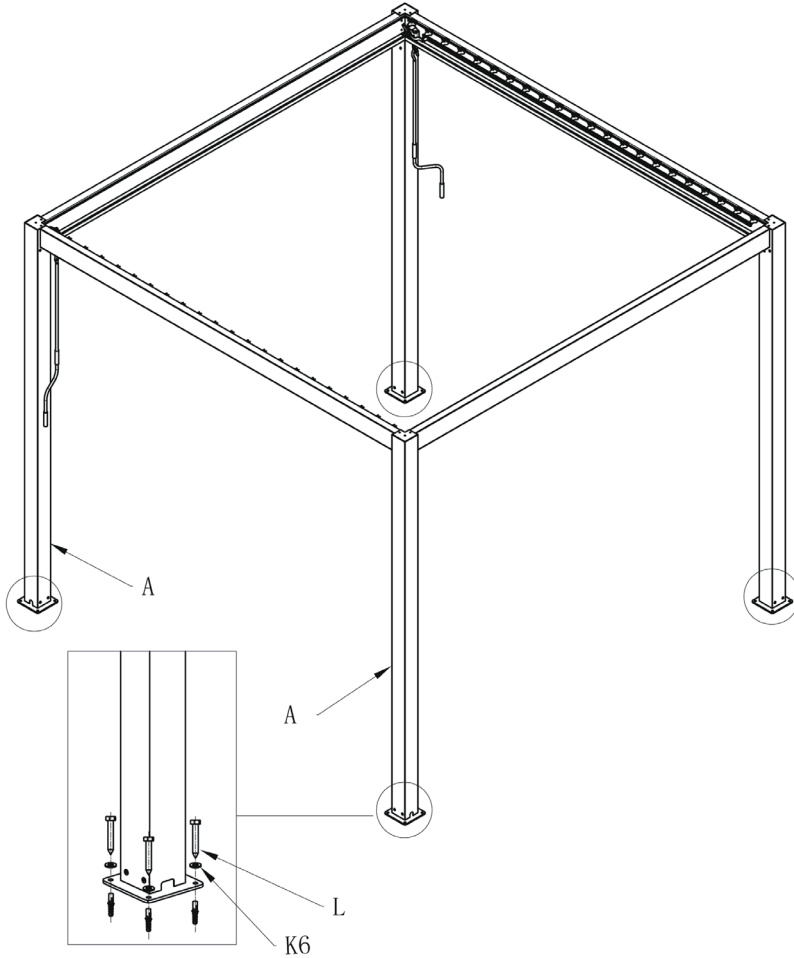

QTY: 16PCS

12

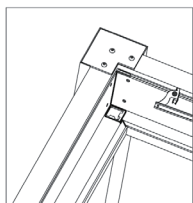

Étalez uniformément la colle pour verre (M) autour du drain de la colonne et des joints de piliers (voir image zoomée).

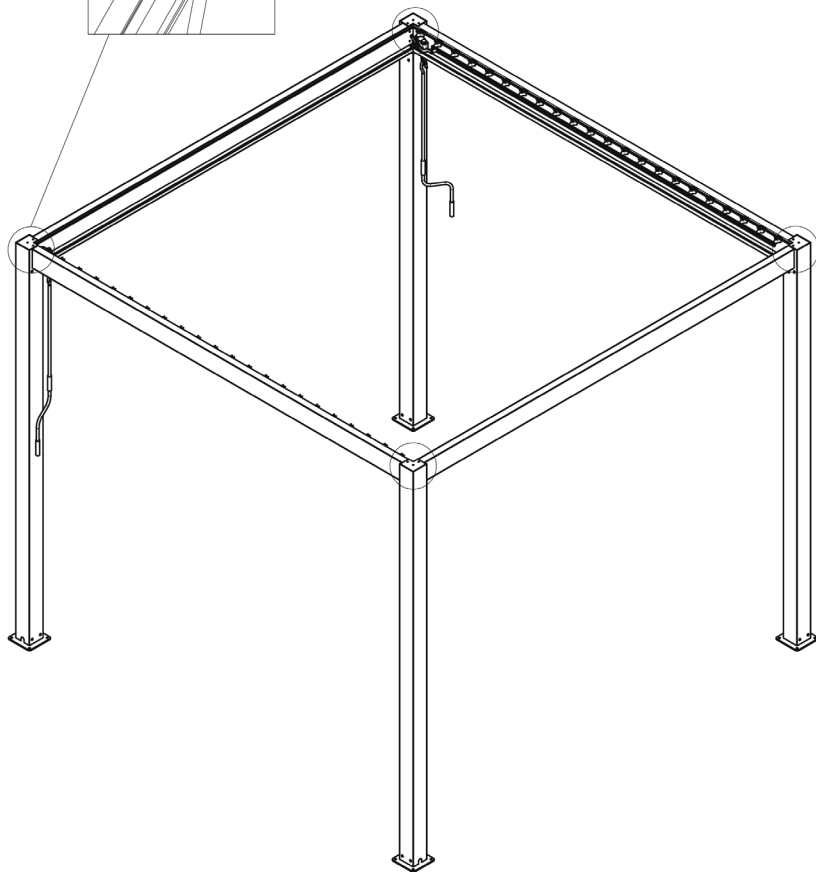
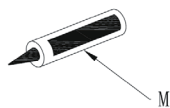

M



QTY: 1PC



13

Placez la poutre du milieu (D) au-dessus des poutres avant et arrière (C).

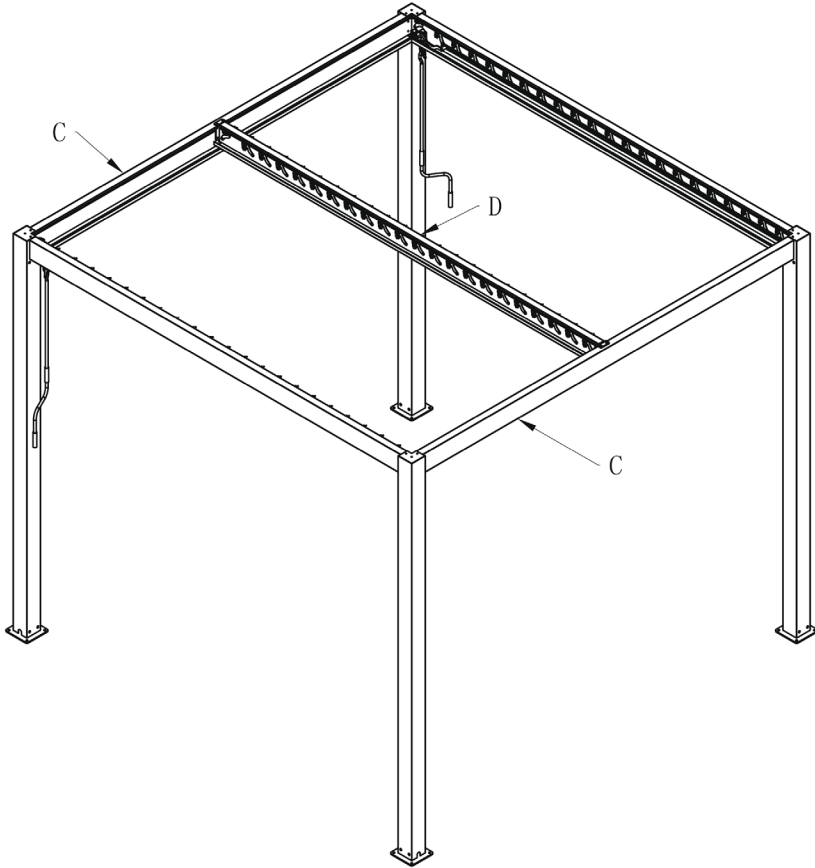

Insérez 6 des lamelles (E) dans l'extrémité des supports de chaque côté des poutres (B1 et B2) et poussez les lamelles vers le bas pour les fixer.

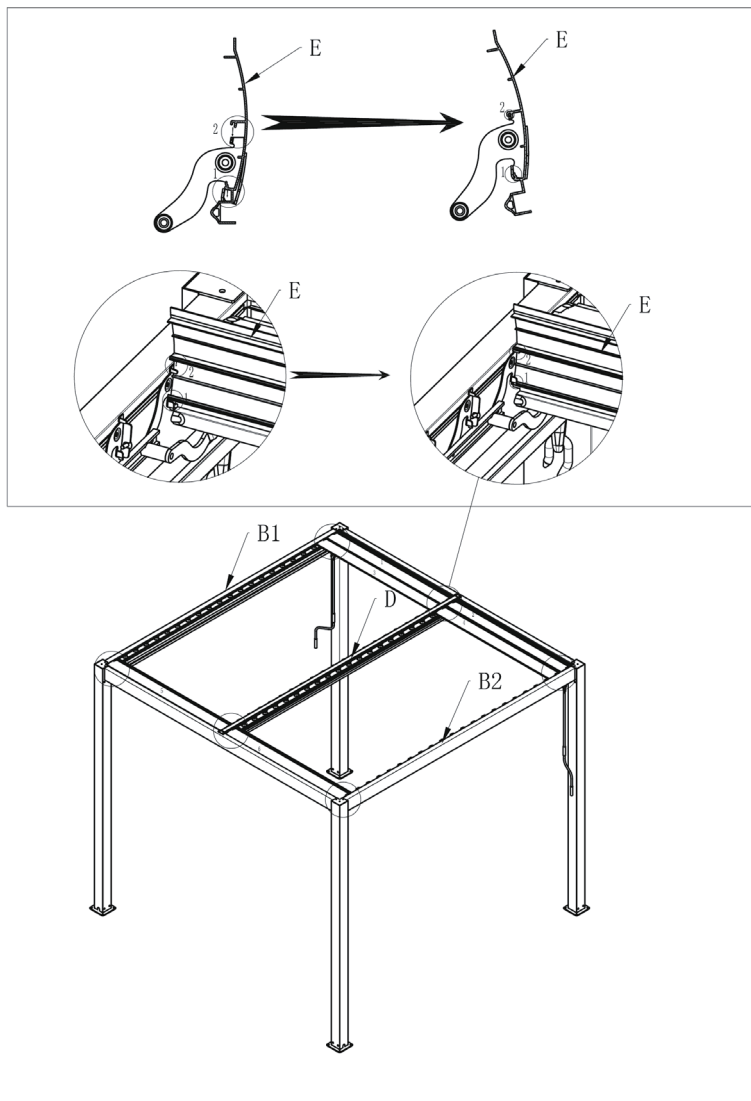

15

Fixez d'abord la vis (K2) avec la rondelle (K3) dans le trou sous la poutre (D). Répétez cette étape pour la poutre (C). Insérez ensuite les autres lamelles l'une après l'autre.

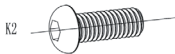
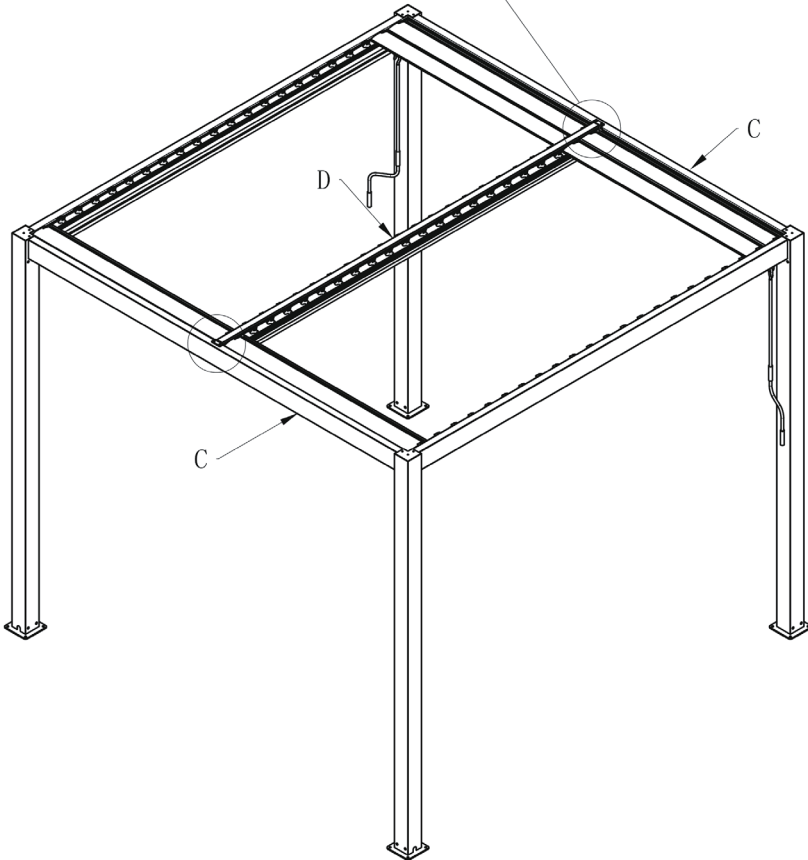
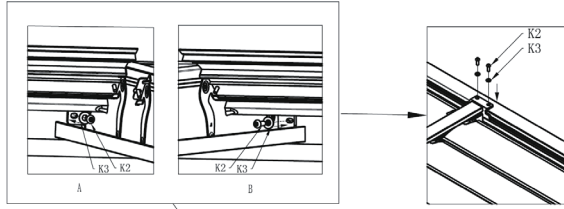

QTY: 8PCS



QTY: 8PCS

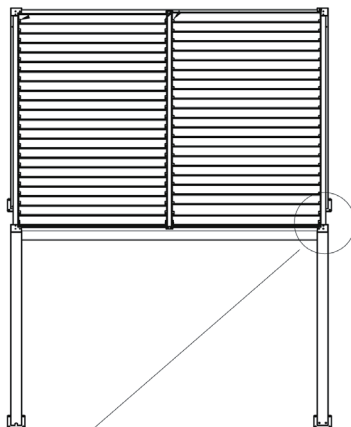

Ajustez la pergola selon les étapes suivantes si elle ne se ferme pas complètement.

A : trou de la lamelle  
B : trou des supports de lamelles

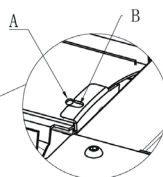
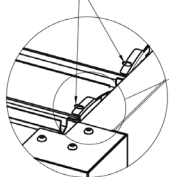

Ajustez l'installation comme suit, si le trou A et le trou B ne sont pas correctement alignés

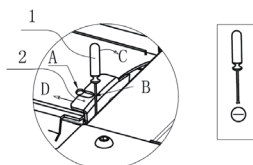

Ajustez le support de lamelle (B) avec un tournevis droit.

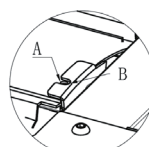

Les trous A et B doivent être superposés après le réglage.

Insérez le cache en plastique (N) des deux côtés de chaque lamelle.

L'illustration montre comment le couvercle en plastique (N) s'insère dans la lamelle de devant.

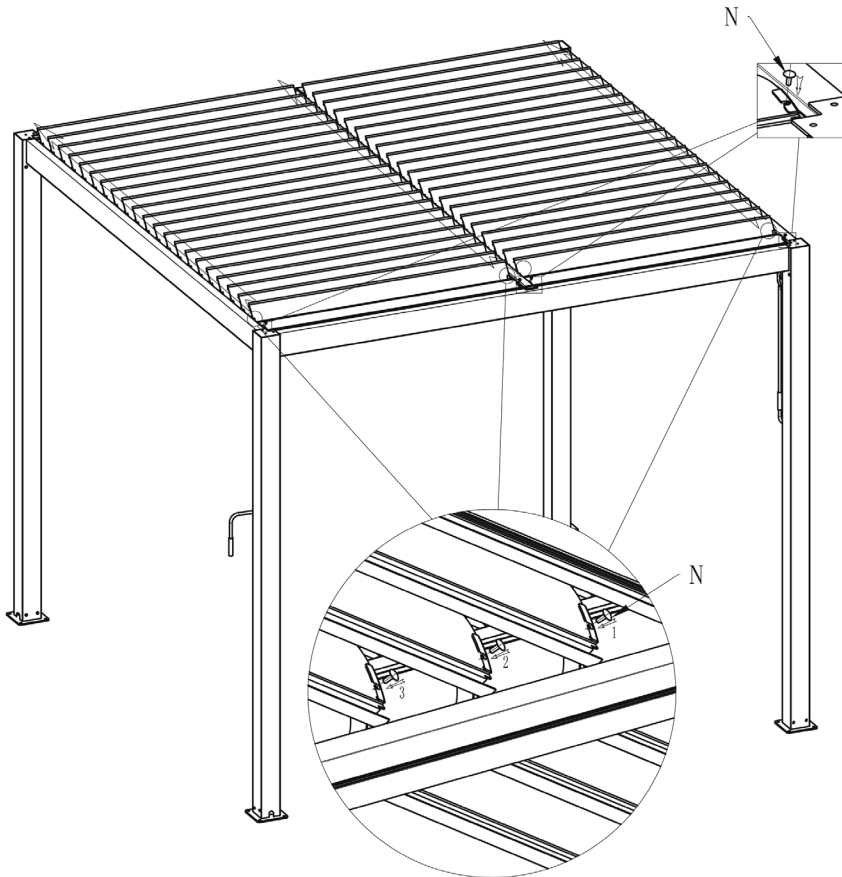

Tournez les lamelles en demi-position et insérez les caches en plastique (N) l'un après l'autre dans le trou aux deux extrémités de chaque lamelle.

Enfin, fixez les deux manivelles (J) pour ouvrir et fermer les lamelles.  
L'installation de la pergola est maintenant terminée.

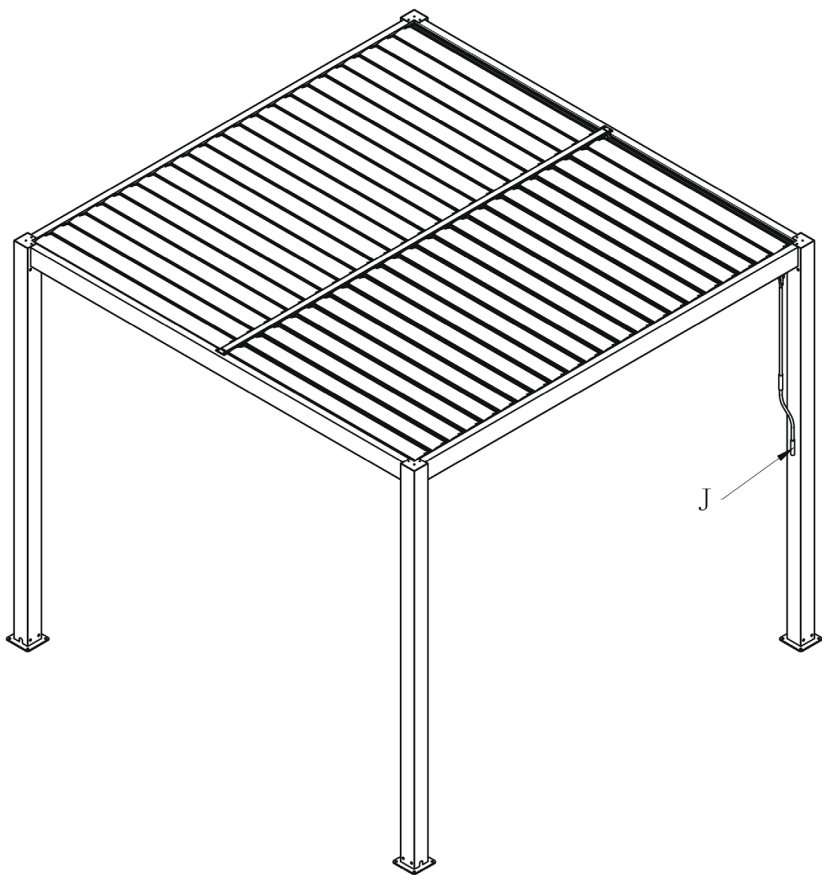

20

**Étape 2 :** Fixez séparément l'extrémité mâle (M) du faisceau (B1) et l'extrémité femelle (W) du faisceau (C) à l'alimentation électrique. Serrez ensuite les capuchons à vis à l'extrémité des câbles d'éclairage.

**Étape 3 :** Fixez le bloc d'alimentation à la poutre (C) à l'aide des vis (K5). Réglez la couleur de la lumière en fonction de l'éclairage avec la télécommande (P).

**Étape 1 :** Connectez l'extrémité (M) du câble d'éclairage du faisceau (B2) à l'extrémité (W) du câble d'éclairage du faisceau (C), puis serrez le capuchon à vis. À l'exception du point de connexion des faisceaux (B1) et (C), les autres câbles d'éclairage doivent être connectés de la même manière dans le sens des aiguilles d'une montre.

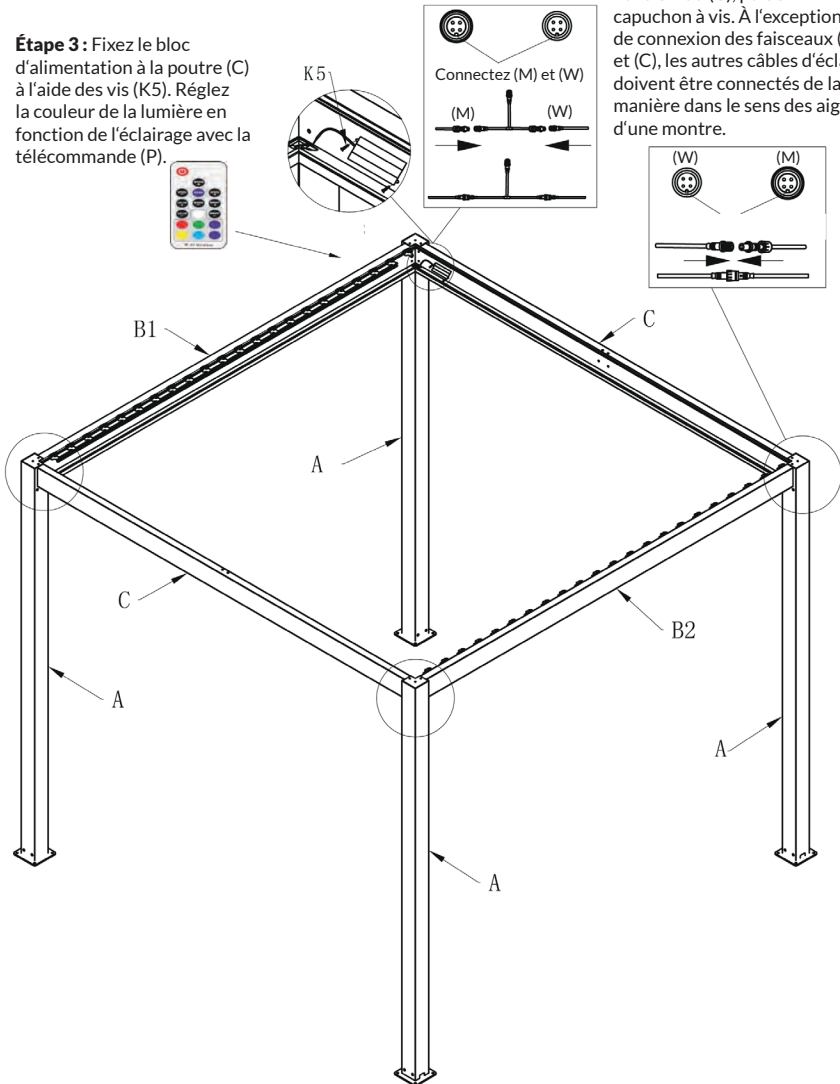

P



QTY: 1PCS

K 5



QTY: 2PCS

# INSTALLATION DU PANNEAU SOLAIRE

21

**Étape 2 :** Connectez les supports (S) avec (K9) et (K10) et fixez les supports (S) au panneau solaire avec les vis (K8).

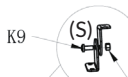

K10

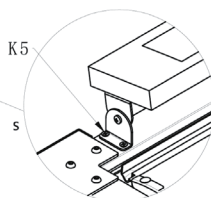

K5

S

**Étape 3 :** Fixez les supports (S) à la poutre avec les vis (K5).

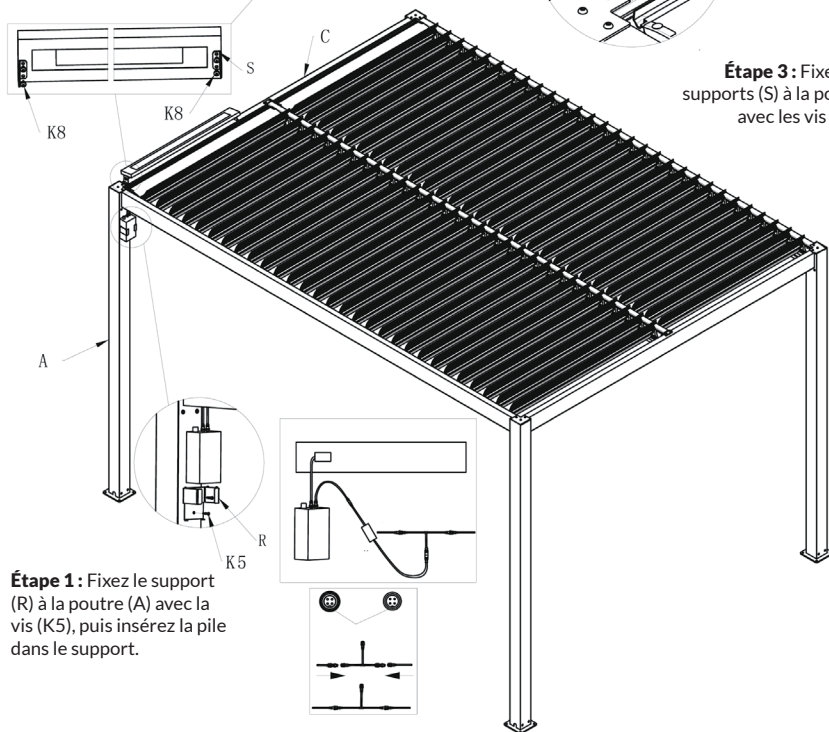

**Étape 1 :** Fixez le support (R) à la poutre (A) avec la vis (K5), puis insérez la pile dans le support.

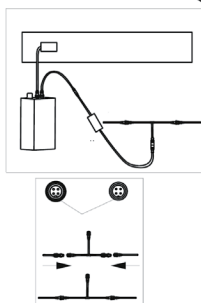

R



QTY: 1PCS

K5



QTY: 6PCS

K8



QTY: 4PCS

S



QTY: 4PCS

K9



QTY: 2PCS

K10



QTY: 2PCS



## REMARQUES SUR LES BATTERIES LITHIUM ION

### Spécifications

Tension nominale	11,1 V
Puissance nominale	10 Ah
Entrée	12,6 V / 3 A Max.
Sortie	12 V (9 - 12,6 V) / 6 A Max.
Dimensions	158 x 90 x 60 mm (Boîtier)
Poids	0,8 kg

### Aperçu de l'appareil

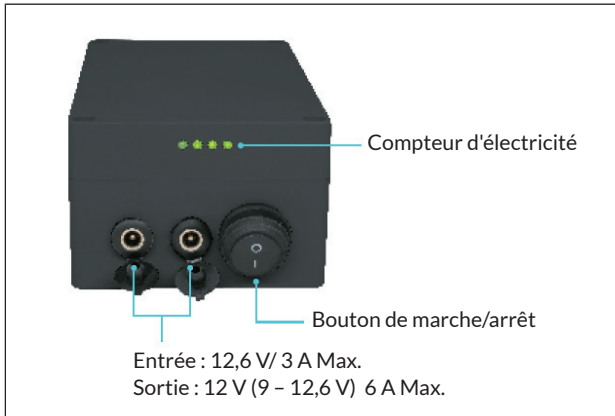

### Consignes de sécurité

- Soyez extrêmement prudent lorsque vous manipulez l'appareil, ne le laissez pas tomber et ne le renversez pas. N'essayez jamais de démonter l'appareil.
- N'utilisez jamais l'appareil dans un environnement humide ou dans l'eau. Utilisez l'appareil dans un endroit sec et bien ventilé.
- Cet appareil comporte des batteries au lithium ion. Tenez l'appareil éloigné des sources d'incendie.
- Lorsque vous prévoyez de ne pas utiliser l'appareil pendant une longue période, il est malgré tout recommandé de le charger tous les 3 mois pour garantir la durée de vie de la batterie.
- Chargez la batterie uniquement avec un câble de charge conforme aux exigences.
- Contactez le fabricant ou le service client en cas de dysfonctionnement.

### Conseils pour la recharge

1. Cet appareil ne peut être utilisé qu'avec le chargeur 12,6 V configuré par le fabricant et peut être chargé par la prise de charge CC.
2. N'utilisez aucun autre chargeur pour charger la batterie.
3. Le voyant de l'appareil est rouge lorsque la charge n'est pas terminée.
4. Le voyant du chargeur s'allume en vert ou en bleu lorsque la charge est terminée ou qu'il n'y a pas de charge. Veuillez débrancher le chargeur de la prise une fois la charge terminée.
5. Si le témoin de contrôle du module de charge solaire s'allume en rouge et clignote, cela indique qu'aucune charge n'est en cours. Si le témoin de contrôle s'allume en orange, le processus de charge est en cours. Le voyant est vert lorsque la batterie est complètement chargée.

## UTILISATION DE LA TÉLÉCOMMANDE

### Fonctions

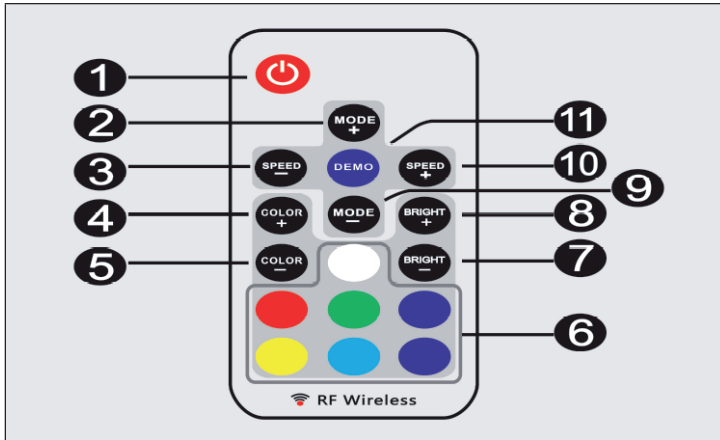

	Marche / veille
1	Appuyez sur cette touche pour allumer l'appareil ou pour le mettre en mode veille. Au démarrage, l'état précédent est automatiquement restauré.
2/9	Réglage du mode dynamique Appuyez sur cette touche pour passer du mode statique au mode couleur dynamique ou basculer entre les modes dynamiques.
3/10	Réglage dynamique de la vitesse Appuyez sur la touche SPEED + pour augmenter la vitesse et sur la touche bouton SPEED- pour la réduire. Si vous appuyez sur cette touche en mode statique, l'appareil passe en mode dynamique.
4/5	Réglage statique de la couleur Appuyez sur cette touche pour passer du mode dynamique au mode couleur statique ou basculer entre les couleurs statiques.

6	Sélection directe de couleur
	Cette touche vous conduit directement à la sélection de couleur statique. Appuyez sur une touche de couleur spécifique pour allumer la LED dans la couleur correspondante. La sélection directe des couleurs est incluse lors de l'utilisation des boutons COLOR + et COLOR-.
7/8	Réglage de la luminosité
	Réglage de la luminosité des couleurs statiques Appuyez sur BRIGHT + pour augmenter la luminosité et sur BRIGHT- pour diminuer la luminosité. L'appareil passe automatiquement en mode couleur statique si vous appuyez sur cette touche en mode dynamique.
11	Mode démo
	Appuyez sur cette touche pour accéder au mode démo En mode démo, 17 modes dynamiques sont joués en boucle continue et chaque mode est répété trois fois.

## INSTALLATION DU CONTRÔLEUR LED

### Alimentation

Cet appareil peut utiliser une alimentation entre DC 5 V et 24 V. Le pôle intérieur (ou le fil rouge) de la prise CC est positif et le manchon (ou le fil noir) est négatif. Assurez-vous également que la tension du secteur correspond à la tension de la LED.

### Sortie LED

Cet appareil prend en charge les produits LED conventionnels avec connexion anodique. Le marquage [▲] montre le nœud de connexion commun.

Le courant de sortie de crête est de 4 ampères et le courant continu maximum est de 2 ampères par canal. Veuillez réduire la charge si l'unité principale surchauffe.

**Remarque :** Les sorties LED ne doivent pas être court-circuitées ou surchargées. Cela peut entraîner des dommages définitifs !

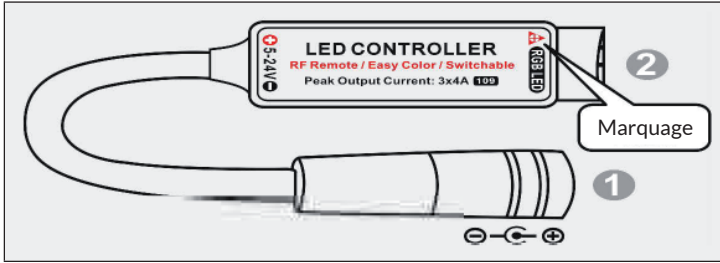

### Utilisation avec la télécommande

Retirez le ruban isolant de la batterie avant utilisation. Le signal de la télécommande sans fil peut traverser les barrières, il n'est donc pas nécessaire de viser l'unité principale. Pour assurer une réception correcte du signal de la télécommande, veuillez ne pas installer l'unité principale dans un boîtier métallique fermé.

### Appairage d'une nouvelle télécommande

La télécommande et l'unité principale sont jumelées par défaut. De plus, l'unité principale peut être reliée à 3 autres télécommandes. Veuillez procéder comme suit pour coupler une nouvelle télécommande :

1. Éteignez l'unité principale, débranchez-la et attendez 5 secondes. Rebranchez ensuite la fiche et démarrez l'unité principale.
2. Dans les 5 secondes après la mise en marche, appuyez simultanément sur les touches [COLOR-] et [BRIGHT-].

Ce processus permet à l'unité principale de reconnaître la nouvelle télécommande.

### **Mode d'appairage libre de la télécommande**

Dans certains cas particuliers, l'unité principale doit être couplée avec n'importe quelle télécommande.

1. Éteignez l'unité principale, débranchez-la et attendez 5 secondes. Rebranchez ensuite la fiche et démarrez l'unité principale.
2. Dans les 5 secondes après la mise en marche, appuyez simultanément sur les boutons [ON / STANDBY] et [MODE +].

Ce processus permet à l'unité principale de reconnaître toutes les télécommandes disponibles. Pour jumeler l'unité principale avec une télécommande spécifique, répétez la procédure "Jumeler une nouvelle télécommande".

### **Changer la séquence des couleurs de sortie**

L'ordre par défaut des couleurs de sortie du contrôleur est vert-rouge-bleu. Si les touches de couleurs ne correspondent pas à la couleur de la LED, ajustez l'ordre des couleurs de sortie comme suit :

1. Éteignez l'unité principale, débranchez-la et attendez 5 secondes. Rebranchez ensuite la fiche et démarrez l'unité principale.
2. Dans les 5 secondes après la mise en marche, appuyez simultanément sur les touches [ROUGE] et [BLEU].

Ce processus fait basculer la séquence de sortie entre 6 combinaisons possibles. Les 6 combinaisons possibles sont enregistrées et activées lors de la prochaine mise hors et sous tension de l'appareil.

---

## INFORMATIONS SUR LE RECYCLAGE

---



S'il existe une réglementation pour l'élimination ou le recyclage des appareils électriques et électroniques dans votre pays, ce symbole sur le produit ou sur l'emballage indique que cet appareil ne doit pas être jeté avec les ordures ménagères. Vous devez le déposer dans un point de collecte pour le recyclage des équipements électriques et électroniques. La mise au rebut conforme aux règles protège l'environnement et la santé de vos semblables des conséquences négatives. Pour plus d'informations sur le recyclage et l'élimination de ce produit, veuillez contacter votre autorité locale ou votre service de recyclage des déchets ménagers.

Ce produit contient des piles. S'il existe une réglementation pour l'élimination ou le recyclage des piles dans votre pays, vous ne devez pas les jeter avec les ordures ménagères. Renseignez-vous sur les dispositions locales relatives à la collecte des piles usagées. La mise au rebut conforme aux règles protège l'environnement et la santé de vos semblables des conséquences négatives.

---

## FABRICANT ET IMPORTATEUR (UK)

---

**Fabricant :**

Chal-Tec GmbH, Wallstraße 16, 10179 Berlin, Allemagne.

**Importateur pour la Grande Bretagne :**

Berlin Brands Group UK Ltd

PO Box 1145

Oxford, OX1 9UW

United Kingdom





**Estimado cliente:**

Le felicitamos por la adquisición de este producto. Lea atentamente el siguiente manual y siga cuidadosamente las instrucciones de uso con el fin de evitar posibles daños. La empresa no se responsabiliza de los daños ocasionados por un uso indebido del producto o por haber desatendido las indicaciones de seguridad.

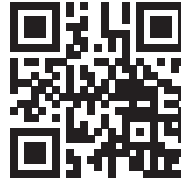

---

## ÍNDICE

---

Componentes	102
Montaje	105
Instalación Del Panel Solar	124
Notas sobre la batería de iones de litio	125
Uso del mando a distancia	127
Instalación del controlador LED	128
retirada del aparato	131
Fabricante e importador (Reino Unido)	131

















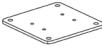
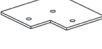

---









## DATOS TÉCNICOS

---

Número de artículo	10035942 10035943	10035944 10035945
Dimensiones	3x3 m	3x4 m

## COMPONENTES

Núm.	Descripción	Imagen	Uds.
A	Columna		4
B1	Barra (izquierda)		1
B2	Barra (derecha)		1
C	Barra (delantera y trasera)		2
D	Barra central		1
E	Lama		3x3=44 3x4=60
F	Placa base de la columna		4
G	Cubierta de la columna		4
H	Conector para la barra central		2
I	Bisagra de anilla		2
J	Manivela		2
K1	Tornillo avellanado	 M6x16	40+2
K2	Tornillo de cabeza plana	 M6x16	20+2
K3	Arandela	 D6x12	8+2
K4	Tornillo y tuerca	 M4x25	2
K5	Tornillo autorroscante	 ST4.2x25	8
K8	Tornillo	 ST4.8x10	4
K9	Tornillo	 M5x12	2
K10	Tuerca	 M5	2

Núm.	Descripción	Imagen	Uds.
L	Tornillo para madera, taco y arandela		16
M	Adhesivo transparente		1
N	Cubierta de plástico		3x3=88 3x4=120
P	Mando a distancia		1
Q	Desagüe		4
R	Pinza		1
S	Soporte		4
T	Panel solar		1
H	Batería		1

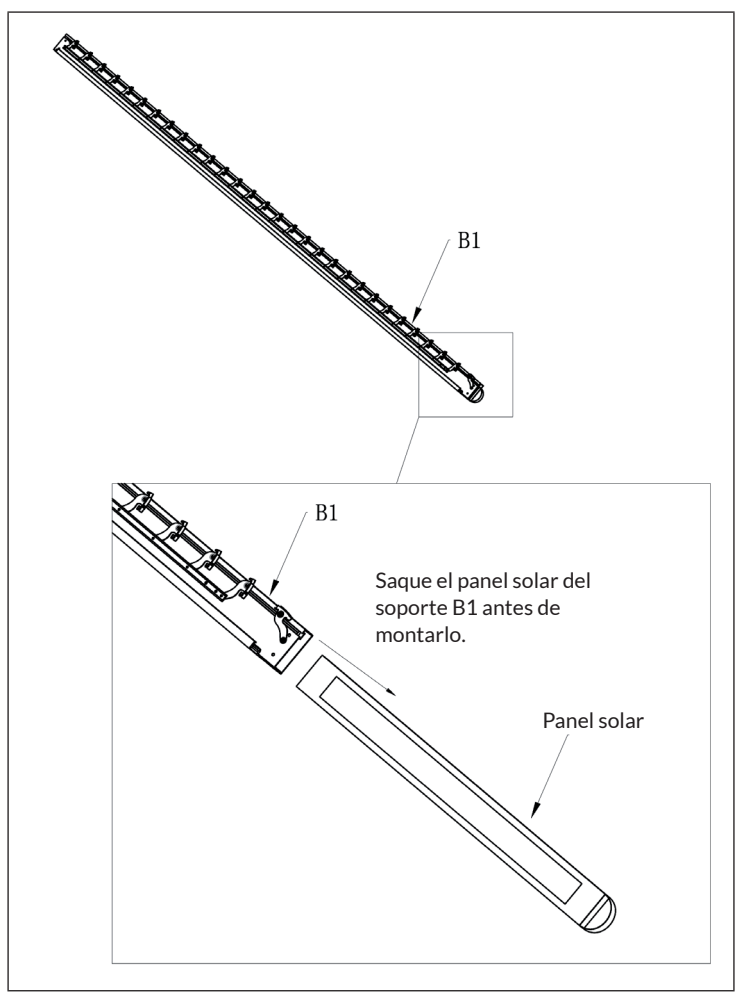

# MONTAJE

**Indicaciones sobre los datos de las imágenes:** QTY = Cantidad / PCS = Unidades

1

## Encaje el desagüe a la columna

Introduzca el desagüe (Q) en la ranura de la columna. Una la placa base a la columna (A) y apriete los tornillos. Realice este paso para las 4 columnas.

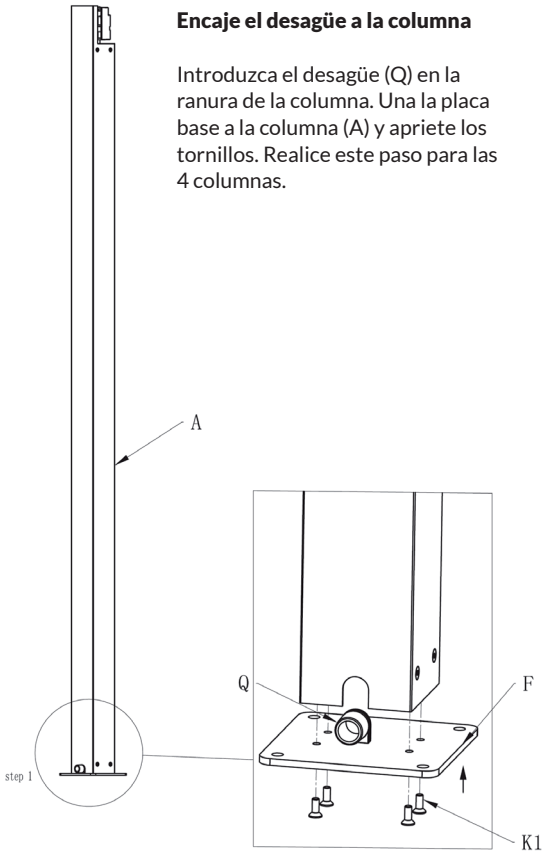

K1  QTY: 16 PCS

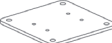
F  QTY: 4 PCS

Q  QTY: 4 PCS

Instale el conector (H) en un lado de la barra central (D). A continuación, apriete el tornillo (K1). Realice los mismos pasos para el otro extremo de la barra

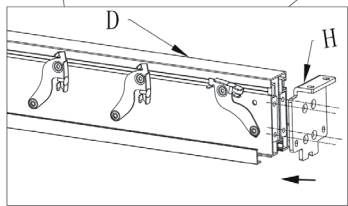
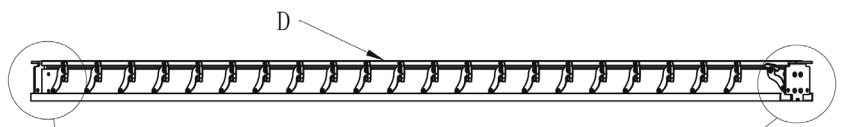

**Paso 1**

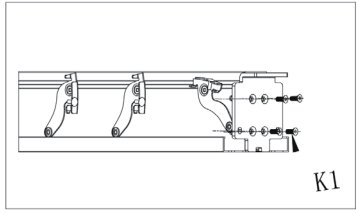

**Paso 2**



3

Coloque las dos bisagras de anilla (I) en el eje de la barra (D) y fije las bisagras de anilla con un tornillo y una tuerca (K4).

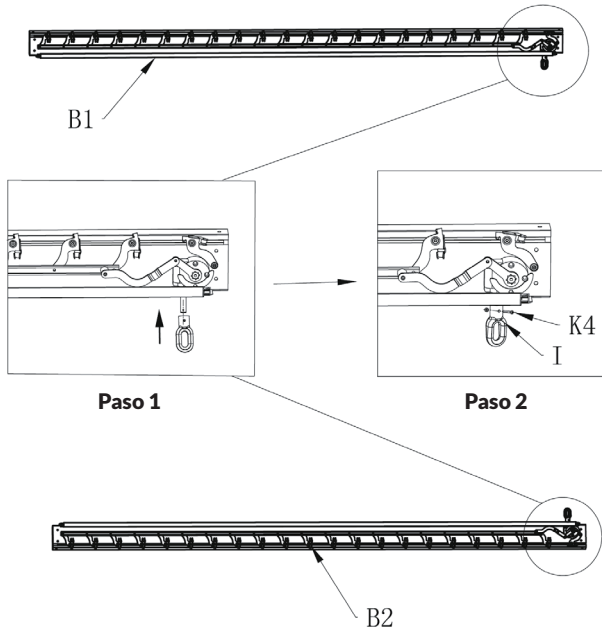

I

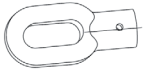

QTY:2PCS

K4

M4



M4x25

QTY:2 SETS

Coloque las columnas y las barras como se muestra en la ilustración, asegurándose de que los desagües de las columnas estén orientados hacia el mismo lado.

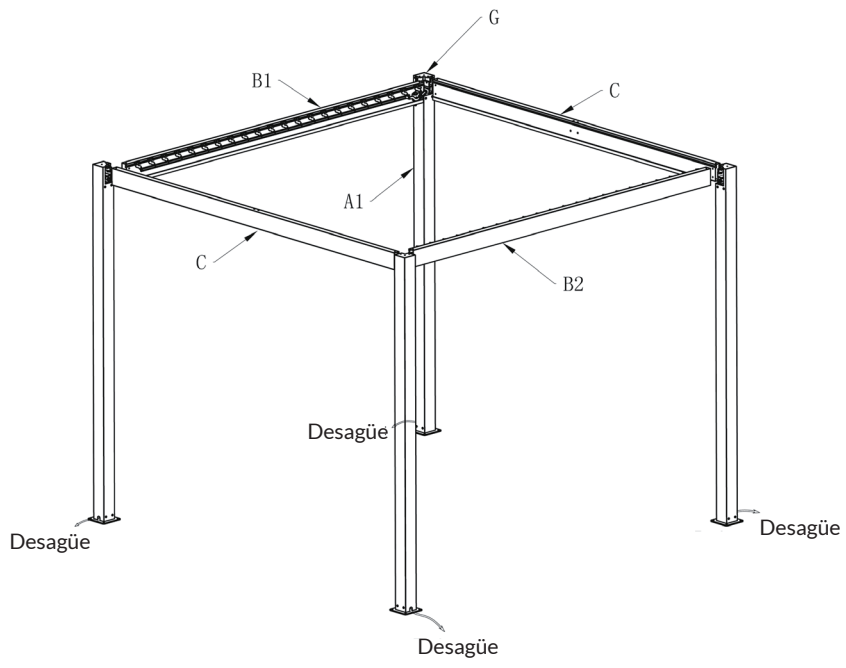



5

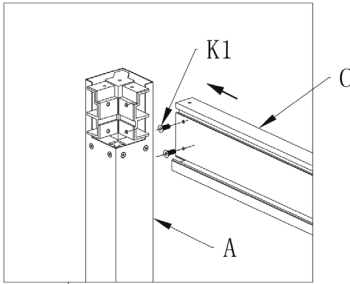

Encaje ambos extremos de las barras delantera y trasera (C) en el conector de esquina de la columna y apriete los tornillos (K1).

**Paso 1**

**Paso 2**

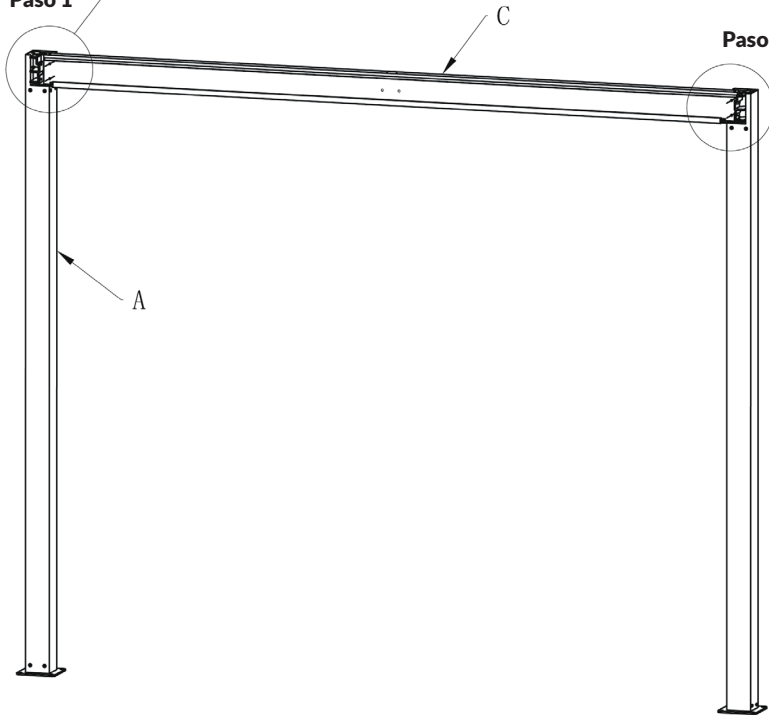

K1

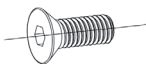

QTY:4PCS

6

Coloque la barra izquierda y derecha (B1&B2) en el conector de esquina de las columnas y fije las barras con tornillos (K1).

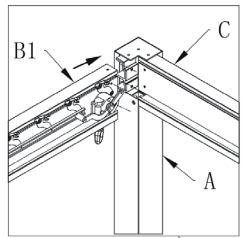

Paso 1

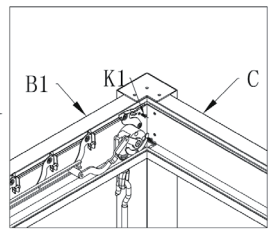

Paso 2

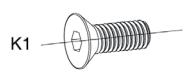
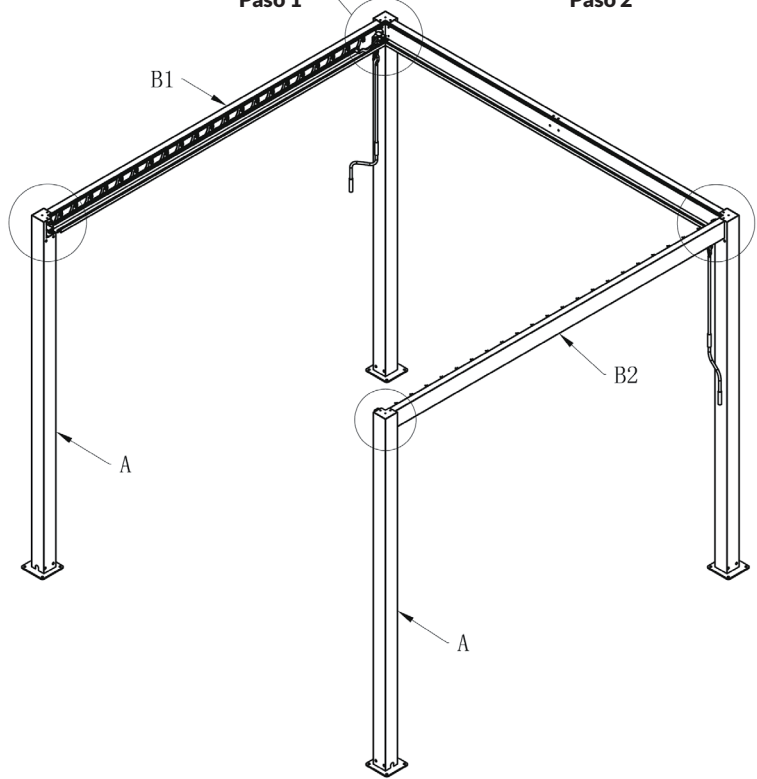

QTY:8PCS

7

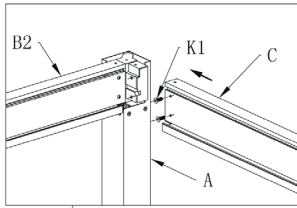

Coloque la barra (C) sobre el conector de esquina de las columnas y fije la barra con tornillos (K1).

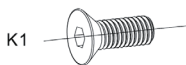
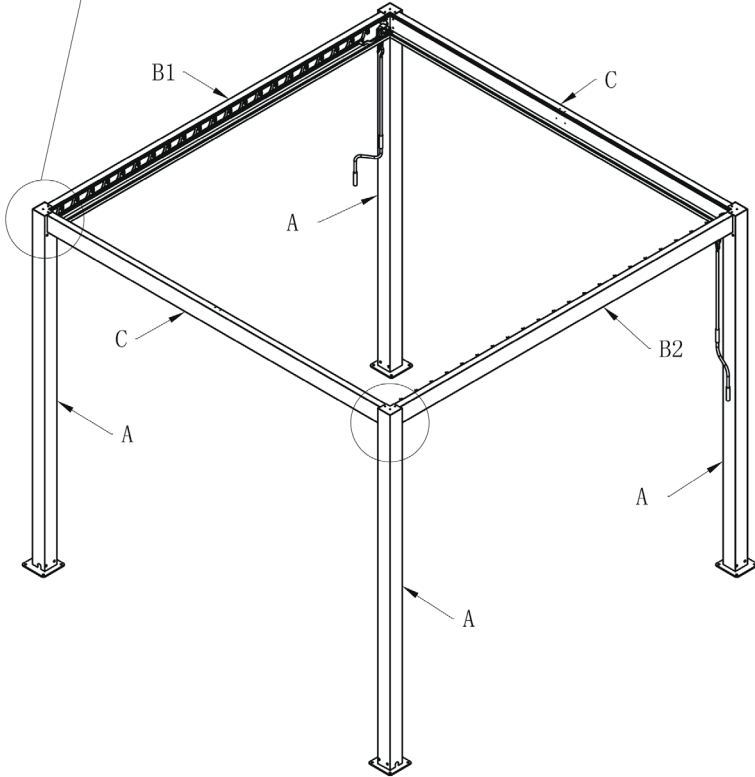

QTY:4PCS

8

Coloque las 4 cubiertas de las columnas (G) en los conectores de esquina de las columnas y fije las cubiertas con tornillos (K2).

**Paso 1** **Paso 2**

**K2**  QTY:12PCS

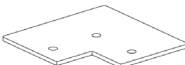
**G**  QTY:4PCS

9

Coloque las cuatro columnas de modo que queden posición vertical con respecto al suelo. La distancia entre las columnas debe ser igual en la parte superior e inferior. A continuación, con un rotulador, marque 16 orificios en el suelo, que deben coincidir con los orificios de las placas base.

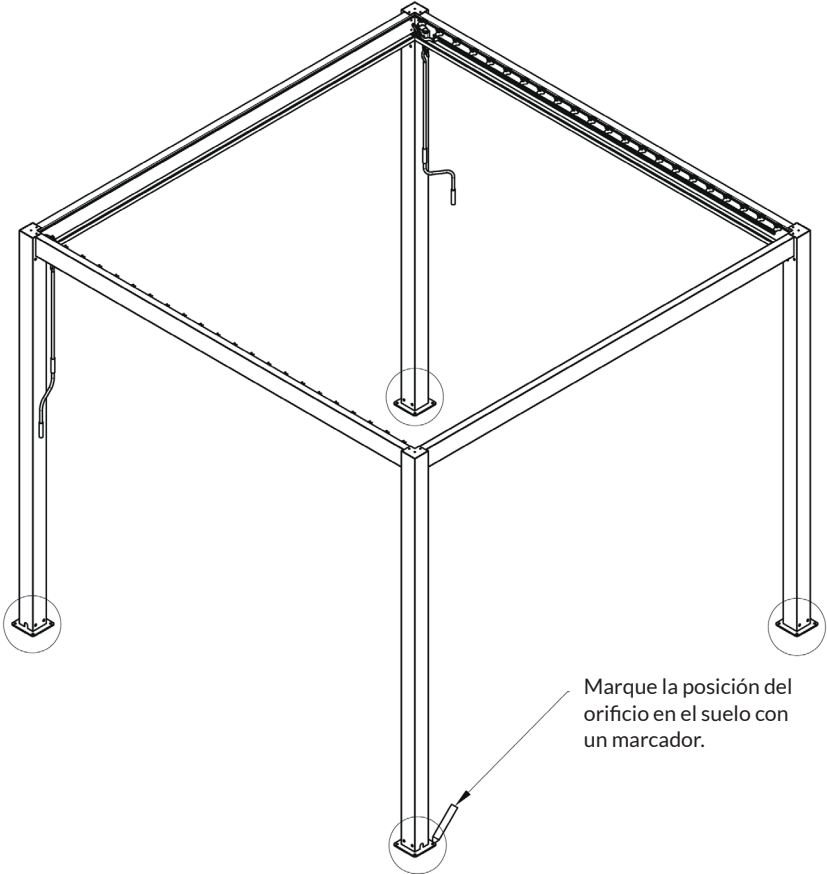

10

Retire la estructura de las marcas y perfore con un taladro las 16 marcas de posición del suelo para hacer orificios de 10 mm de diámetro y 80 mm de profundidad.

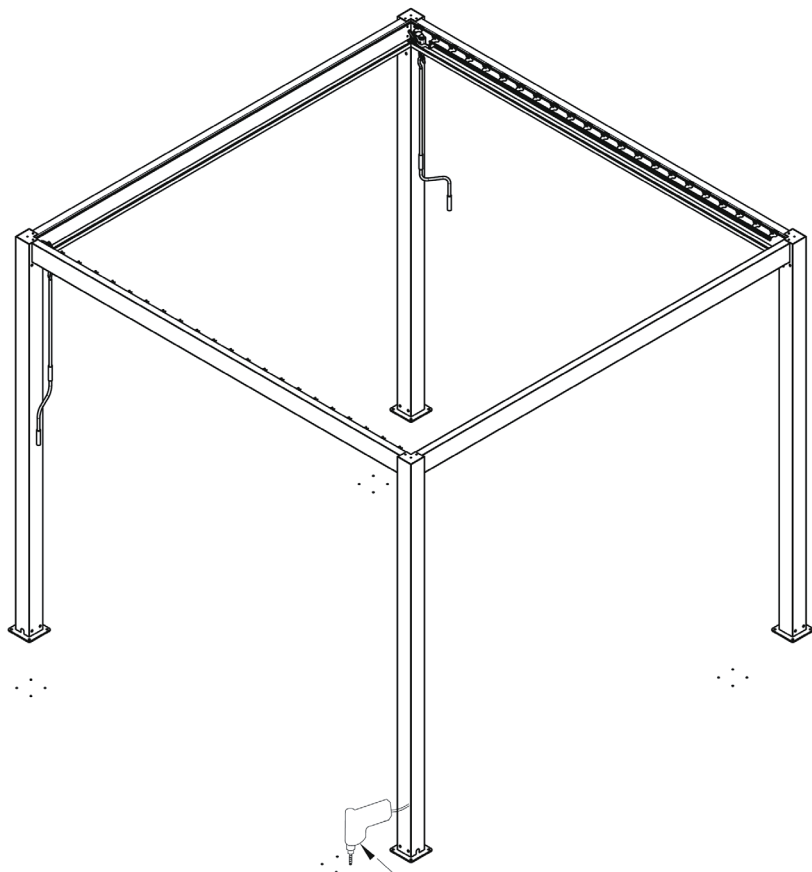

En total, perfore 16 orificios con un diámetro de 10 mm y una profundidad de 80 mm.

11

Coloque los tacos en los orificios del suelo. Coloque la estructura encima de los orificios perforados y alinee estos con los orificios de las placas base de las columnas. Fije las placas base de las columnas con 4 arandelas (K6) y 4 tornillos (L) cada una.

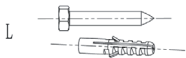
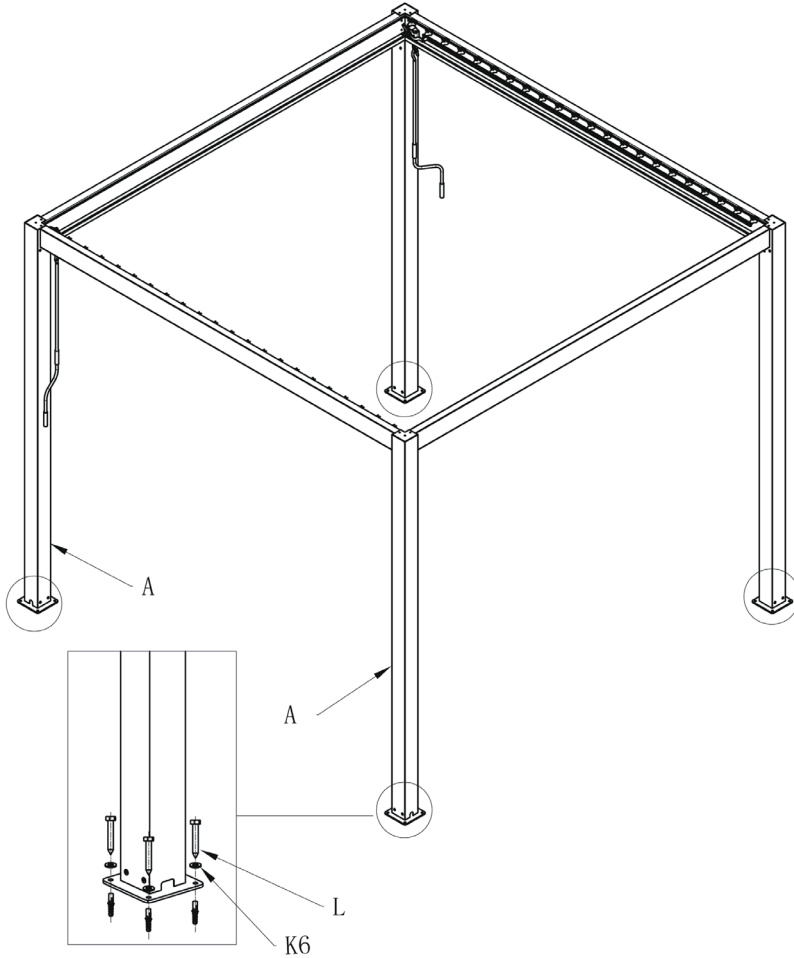

QTY: 16PCS

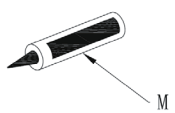
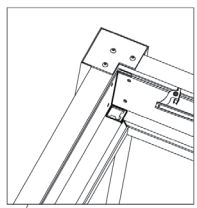

Aplique adhesivo transparente (M) de manera uniforme por el desagüe de las columnas y las juntas de las barras (ver fig. aumentada).

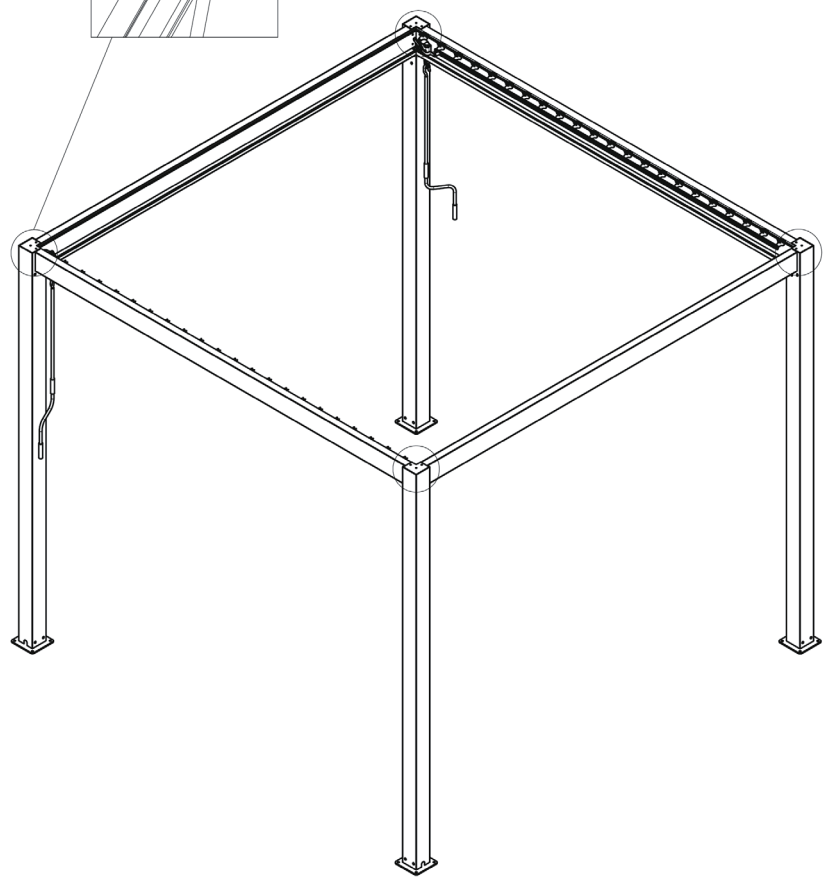

M

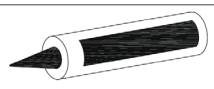

QTY: 1PC



13

Coloque la barra central (D) entre la barra delantera y trasera (C).

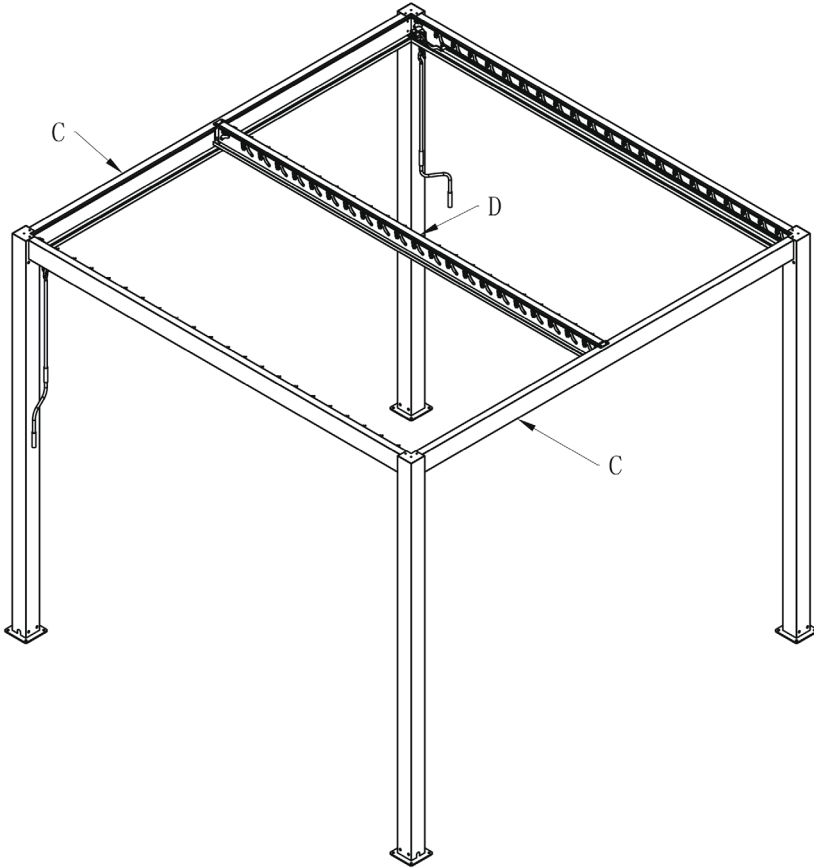

Coloque 6 de las lamas (E) en el extremo de los soportes a ambos lados de las barras (B1 y B2) y presione las lamas hacia abajo para fijarlas.

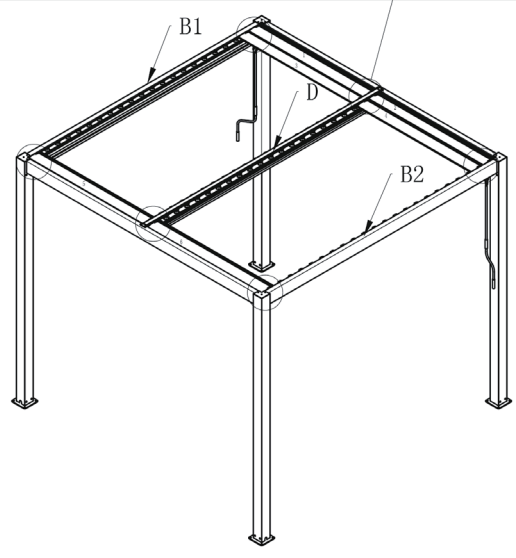
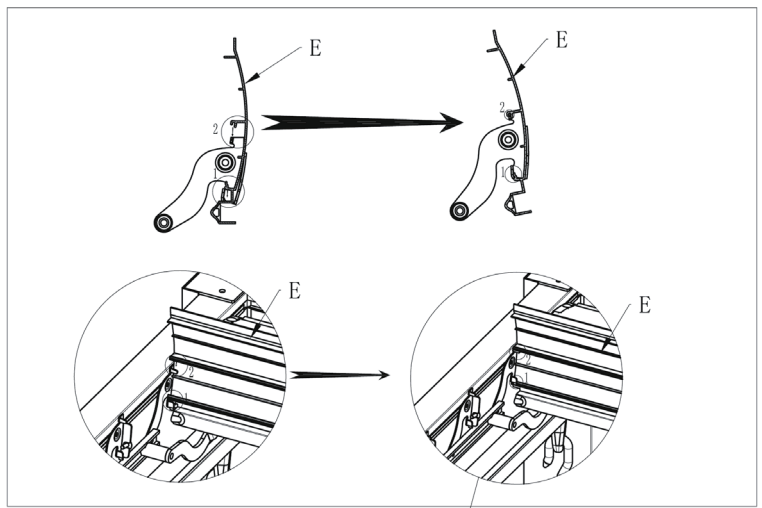

15

Fije primero los tornillos (K2) con las arandelas (K3) en el orificio situado bajo la barra (D). Repita el proceso en la barra (C). Posteriormente, coloque el resto de lamas en fila.

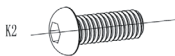
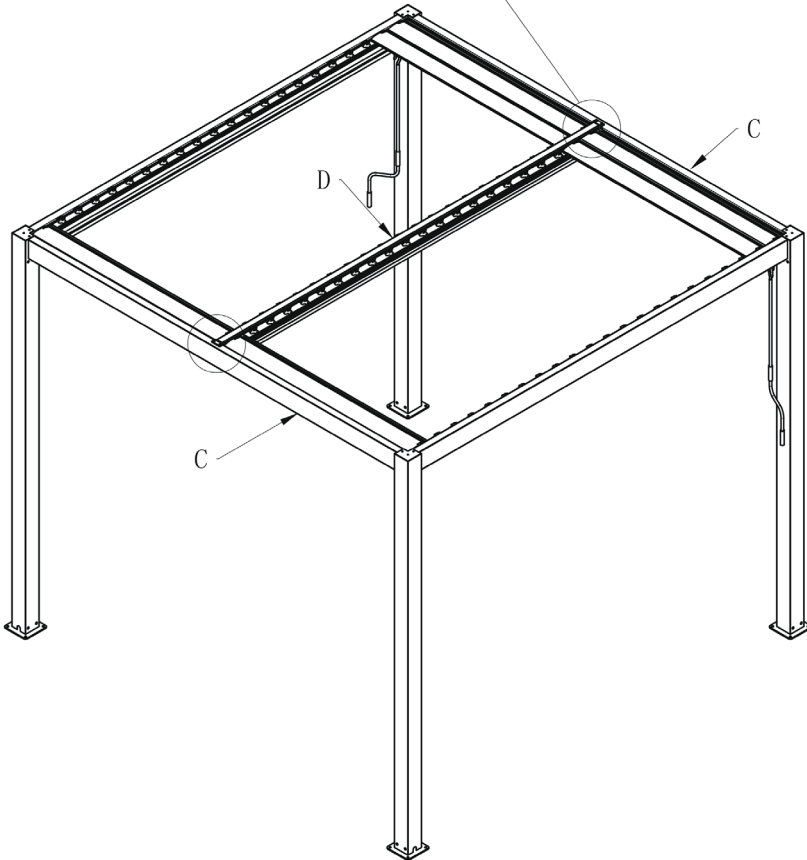
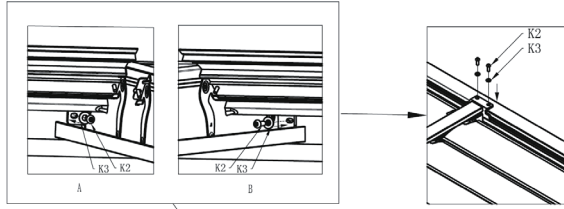

QTY: 8PCS



QTY: 8PCS

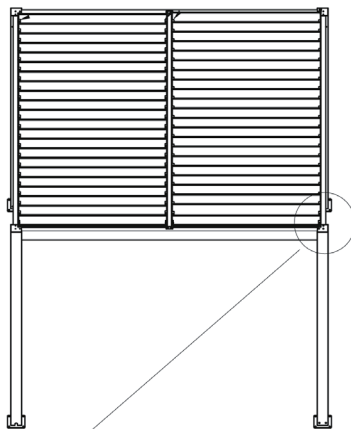

Ajuste la pérgola siguiendo estos pasos en caso de que no se pueda cerrar por completo.

A: Orificio en la lama  
B: Orificio en el soporte de la lama

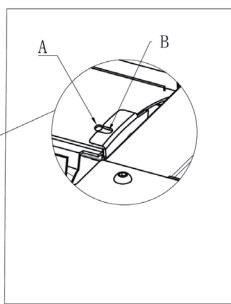
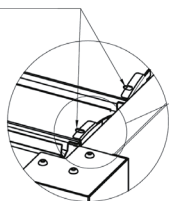

Adapte la instalación como sigue si el orificio A y el orificio B no están superpuestos correctamente:

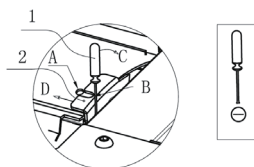

Ajuste los soportes de las lamas (B) con un destornillador en posición recta.

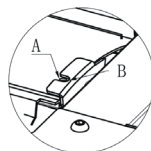

El orificio A y B deben superponerse tras el ajuste.

Coloque la cubierta de plástico (N) a ambos lados de cada lama.

La ilustración muestra cómo la cubierta de plástico (N) se introduce en la primera lama.

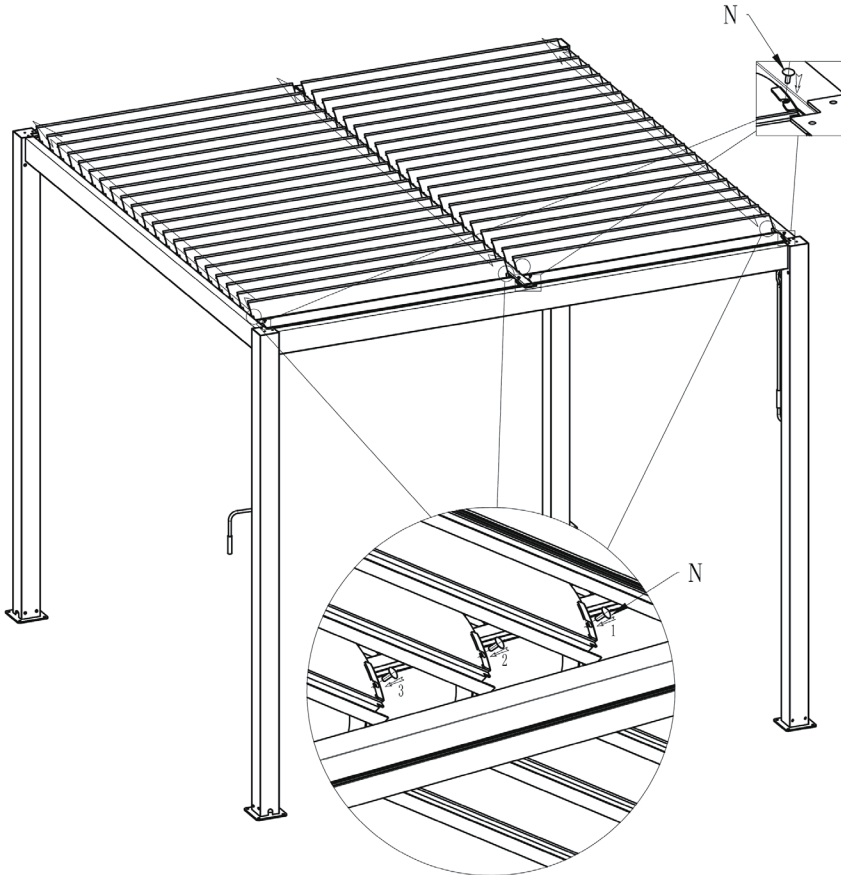

Gire las lamas hasta la posición intermedia y encaje las cubiertas de plástico (N) de manera consecutiva en los orificios de ambos extremos de cada lama.

Para finalizar, fije ambas manivelas (J) para abrir y cerrar las lamas. Ha finalizado la instalación de la pérgola.

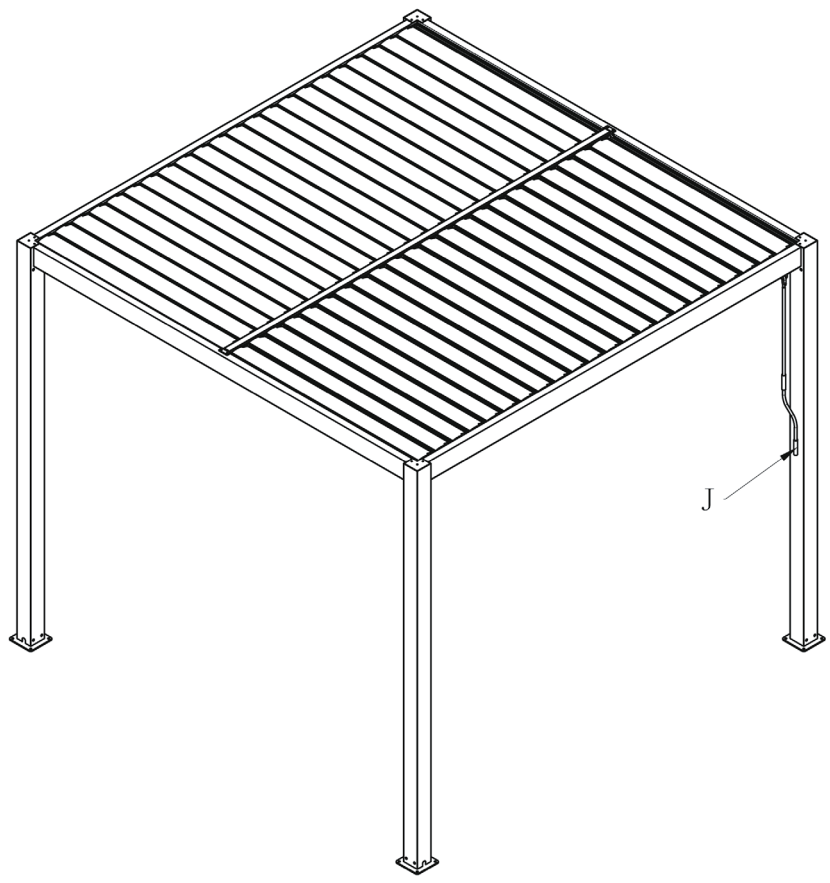

**Paso 2:** Fije el extremo macho (M) de la barra (B1) y el extremo hembra (W) de la barra (C) a la fuente de alimentación por separado. A continuación, apriete los tapones de rosca situados al final del cable de luz.

**Paso 1:** Una el extremo (M) del cable de la luz de la barra (B2) al extremo (W) del cable de la luz de la barra (C) y luego apriete el tapón con rosca. A excepción de los puntos de unión de las barras (B1) y (C), el resto de los cables de luz deben conectarse en sentido horario del mismo modo.

**Paso 3:** Fije la fuente de alimentación con tornillos (K5) a la barra (C). Seleccione el color de la luz tras la iluminación con el mando a distancia (P).

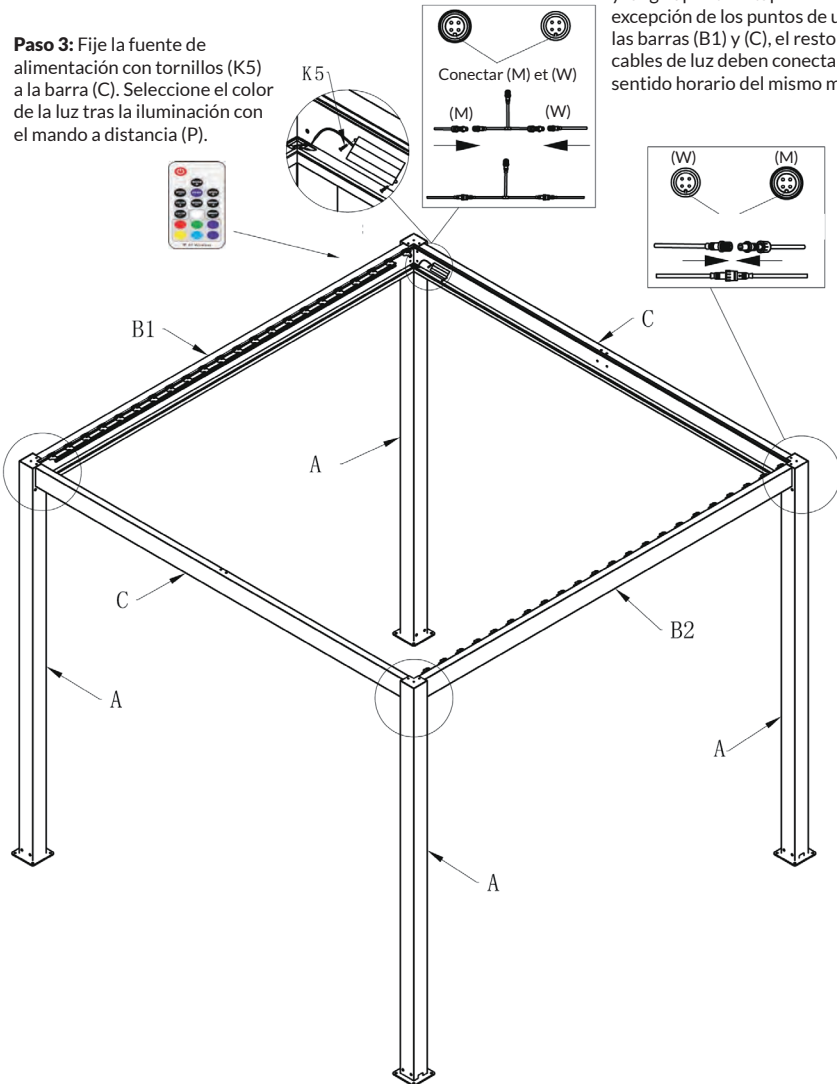

P



QTY: 1PCS

K 5



QTY: 2PCS

# INSTALACIÓN DEL PANEL SOLAR

21



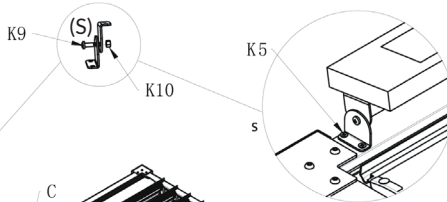

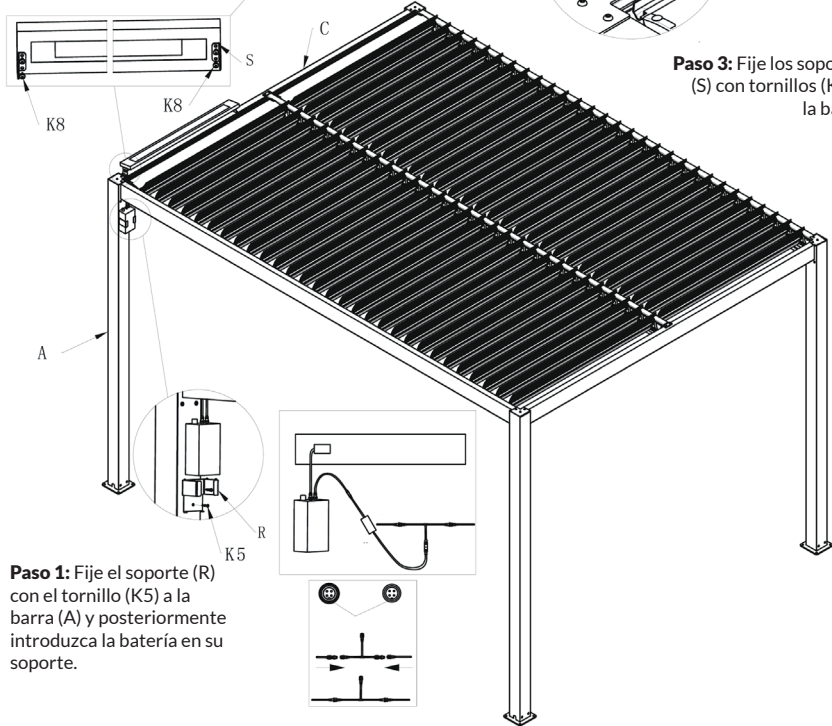

**Paso 2:** Conecte los soportes (S) con (K9) y (K10) y fije los soportes (S) con los tornillos (K8) al panel solar.



**Paso 3:** Fije los soportes (S) con tornillos (K5) a la barra.



**Paso 1:** Fije el soporte (R) con el tornillo (K5) a la barra (A) y posteriormente introduzca la batería en su soporte.

R		QTY: 1PCS	K5		QTY: 6PCS	K8		QTY: 4PCS
S		QTY: 4PCS	K9		QTY: 2PCS	K10		QTY: 2PCS



# NOTAS SOBRE LA BATERÍA DE IONES DE LITIO

## Especificaciones

Tensión nominal	11,1 V
Potencia nominal	10 Ah
Entrada	12,6 V / 3 A máx.
Salida	12 V (9 - 12,6 V) / 6 A máx.
Dimensiones	158 x 90 x 60 mm (carcasa)
Peso	0,8 kg

## Descripción del aparato

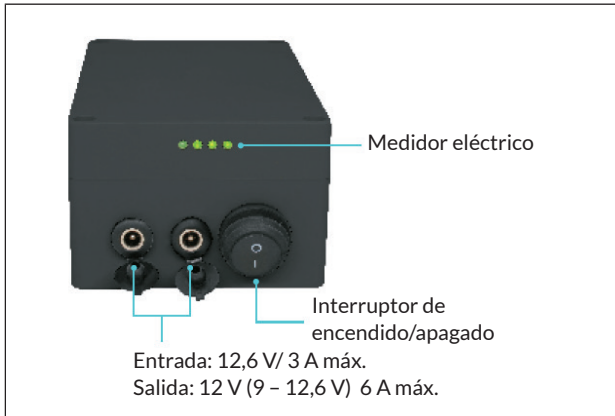

### Indicaciones de seguridad

- Manipule el aparato con extremo cuidado y no lo deje caer ni lo vuelque. En ningún caso intente desmontar el aparato.
- En ningún caso utilice el aparato en entornos húmedos o en el agua. Utilice el aparato en entornos secos y bien ventilados.
- El aparato está equipado con una batería de iones de litio. Mantenga el aparato alejado de fuentes de fuego.
- Si no utiliza el aparato durante un periodo de tiempo prolongado, se recomienda cargarlo cada 3 meses para garantizar la vida útil de la batería.
- Cargue la batería utilizando exclusivamente un cable de carga que cumpla con los requisitos.
- En caso de fallos en el funcionamiento, contacte con el fabricante o el servicio de atención al cliente.

### Indicaciones de carga

1. Este aparato solamente puede ser utilizado con el cargador de 12,6 V configurado por el fabricante y podrá cargarse mediante una toma de carga de CC.
2. No utilice ningún otro cargador para cargar la batería.
3. Si el indicador luminoso del aparato se enciende en color rojo, significa que el proceso de carga no ha finalizado.
4. Si el indicador luminoso del cargador se enciende en color verde o azul, significa que el proceso de carga ha finalizado o que no existe un proceso de carga. Desconecte el enchufe del cargador de la toma de corriente cuando se haya cargado por completo.
5. Si el indicador luminoso del módulo de carga solar se enciende en color rojo intermitente, significa que no se está cargando. Si el indicador luminoso se enciende en color naranja, el proceso de carga está en curso. Si el indicador luminoso se enciende en color verde, significa que la batería está totalmente cargada.

## USO DEL MANDO A DISTANCIA

### Funciones

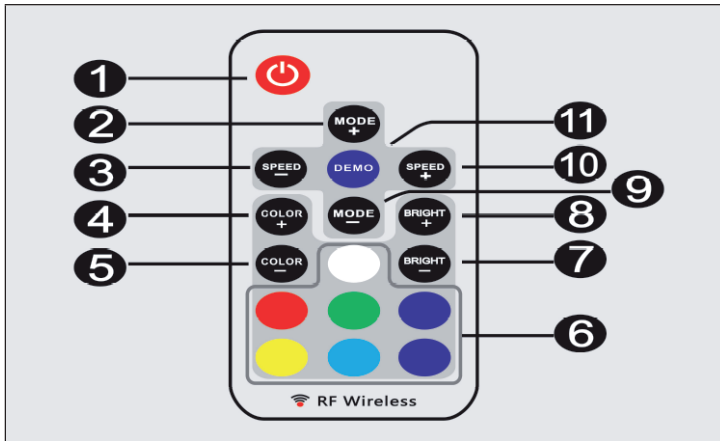

1	Encendido/modo espera
	Presione este botón para encender el aparato o para pasar al modo de espera. Al encender el aparato se restablece el estado previo.
2/9	Ajuste de modo dinámico
	Pulsando este botón puede cambiar del modo estático al modo de color dinámico o elegir entre los distintos modos dinámicos.
3/10	Ajuste dinámico de velocidad
	Pulsado el botón SPEED+ se puede aumentar la velocidad, mientras que con el botón SPEED- se puede reducir. Si se presiona este botón en modo estático, el aparato cambia al modo dinámico.
4/5	Ajuste de color estático
	Pulsando este botón puede pasar del modo de color dinámico al estático o cambiar entre los colores estáticos.

6	Selección directa de color
	Con este botón accede directamente a la selección estática de color. Si pulsa un determinado botón de color, el LED se ilumina en el color correspondiente. La selección directa de color está disponible en los botones COLOR+ y COLOR-.
7/8	Ajustes de brillo
	Ajustes de brillo de los colores estáticos. Para aumentar el brillo, pulse el botón BRIGHT+, y para reducirlo pulse el botón BRIGHT-. El aparato cambia automáticamente al modo de color estático cuando se presiona este botón en modo dinámico.
11	Modo demo
	Al pulsar este botón accederá al modo demo. En el modo demo se reproducirán 17 modos dinámicos en bucle y cada uno de los modos se repetirá tres veces.

## INSTALACIÓN DEL CONTROLADOR LED

### Suministro eléctrico

Para este aparato se puede utilizar un suministro eléctrico de entre 5 V a 24 V CC. El polo interior (o el cable rojo) de la toma de CC es el positivo y el casquillo (o el cable negro) es el negativo. Asimismo, asegúrese de que la tensión de red coincida con la tensión del LED.

### Salida LED

Este aparato es compatible con los productos LED tradicionales con conexión de ánodos. La marca [▲] muestra los nodos de conexión comunes.

La corriente pico de salida corresponde a 4 amperios y la corriente constante máxima es de 2 amperios por canal. Reduzca la carga si el aparato principal se sobrecalienta.

**Nota:** las salidas LED no deben cortocircuitarse ni sobrecargarse. Esto podría ocasionar daños permanentes.

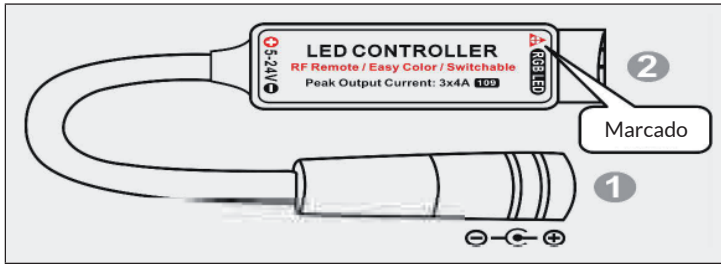

### Manejo del mando a distancia

Antes del uso, retire la cinta aislante de la batería. La señal inalámbrica del mando a distancia puede traspasar barreras, por lo que no es necesario dirigirla al aparato principal durante su uso. Para garantizar una recepción óptima de la señal de mando a distancia, no instale el aparato principal en una carcasa metálica cerrada.

### Sincronizar un mando a distancia nuevo

El mando a distancia y la unidad principal están sincronizados por defecto. Además, la unidad principal puede sincronizarse con otros tres mandos a distancia. Siga estos pasos para sincronizar un mando a distancia nuevo:

1. Apague el aparato, desconecte el enchufe y espere cinco segundos. Vuelva a conectar el enchufe y a poner en marcha el aparato.
2. Presione simultáneamente los botones [COLOR-] y [BRIGHT-] en los siguientes 5 segundos.

Después de este proceso, el aparato detectará el nuevo mando a distancia.

### **Modo de sincronización libre de mando a distancia**

En algunos casos especiales, el aparato principal debe sincronizarse con mandos a distancia aleatorios.

1. Apague el aparato, desconecte el enchufe y espere cinco segundos. Vuelva a conectar el enchufe y a poner en marcha el aparato.
2. Presione simultáneamente los botones [ON/STANDBY] y [MODE+] en los 5 segundos posteriores al encendido.

Después de este proceso, el aparato principal detectará todos los mandos a distancia existentes. Para sincronizar el aparato principal con un mando a distancia concreto, repita el proceso "Sincronizar un mando a distancia nuevo".

### **Cambiar el orden de los colores de salida**

El orden estándar de los colores de salida del controlador es verde-rojo-azul. Si los botones de colores no coinciden con los colores LED, adapte el orden de los colores de salida como sigue:

1. Apague el aparato, desconecte el enchufe y espere cinco segundos. Vuelva a conectar el enchufe y a poner en marcha el aparato.
2. Presione simultáneamente los botones [ROJO] y [AZUL] en los 5 segundos posteriores al encendido.

Con este proceso la frecuencia de salida se cambia entre seis combinaciones posibles. Las seis combinaciones posibles se guardan y se activan tras el próximo apagado y encendido.

---

## RETIRADA DEL APARATO

---



Si en su país existe una disposición legal relativa a la eliminación de aparatos eléctricos y electrónicos, este símbolo estampado en el producto o en el embalaje advierte que no debe eliminarse como residuo doméstico. En lugar de ello, debe depositarse en un punto de recogida de reciclaje de aparatos eléctricos y electrónicos. Una gestión adecuada de estos residuos previene consecuencias potencialmente negativas para el medio ambiente y la salud de las personas. Puede consultar más información sobre el reciclaje y la eliminación de este producto contactando con su administración local o con su servicio de recogida de residuos.

Este producto contiene baterías. Si en su país existe una disposición legal relativa a la eliminación de baterías, estas no deben eliminarse como residuo doméstico. Infórmese sobre la normativa vigente relacionada con la eliminación de baterías. Una gestión adecuada de estos residuos previene consecuencias potencialmente negativas para el medio ambiente y la salud de las personas.

---

## FABRICANTE E IMPORTADOR (REINO UNIDO)

---

**Fabricante:**

Chal-Tec GmbH, Wallstraße 16, 10179 Berlín, Alemania.

**Importador para Gran Bretaña:**

Berlin Brands Group UK Ltd

PO Box 1145

Oxford, OX1 9UW

United Kingdom





**Gentile Cliente,**

La ringraziamo per aver acquistato il dispositivo. La preghiamo di leggere attentamente le seguenti istruzioni per l'uso e di seguirle per evitare possibili danni tecnici. Non ci assumiamo alcuna responsabilità per danni scaturiti da una mancata osservazione delle avvertenze di sicurezza e da un uso improprio del dispositivo. Scansionare il codice QR seguente, per accedere al manuale d'uso più attuale e per ricevere informazioni sul prodotto.



---

## INDICE

---

Componenti	134
Montaggio	137
Installazione Del Pannello Solare	156
Avvertenze inerenti la batteria agli ioni di litio	157
Utilizzo del telecomando	159
Installazione del LED controller	160
Avviso di smaltimento	163
Produttore e importatore (UK)	163

















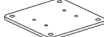

---









## DATI TECNICI

---

Numero articolo	10035942	10035944
	10035943	10035945
Dimensioni	3x3 m	3x4 m

## COMPONENTI

N°	Descrizione	Immagine	Pezzi
A	Colonne		4
B1	Trave (sinistra)		1
B2	Trave (destra)		1
C	Travi (anteriore & posteriore)		2
D	Trave centrale		1
E	Lamelle		3x3=44 3x4=60
F	Pannello di base colonne		4
G	Pannello di copertura colonne		4
H	Connettori per trave centrale		2
I	Anello incernierato		2
J	Manovelle		2
K1	Viti a testa svasata	 M6x16	40+2
K2	Viti a testa piatta	 M6x16	20+2
K3	Rondelle	 D6x12	8+2
K4	Viti & dadi	 M4x25	2
K5	Viti autoperforanti	 ST4.2x25	8
K8	Viti	 ST4.8x10	4
K9	Viti	 M5x12	2
K10	Dadi	 M5	2

Núm.	Descripción	Imagen	Uds.
L	Viti di legno, tasselli e rondelle		16
M	Colla per vetro		1
N	Coperture in plastica		3x3=88 3x4=120
P	Telecomando		1
Q	Connettori di drenaggio		4
R	Morsetto		1
S	Sostegni		4
T	Pannello solare		1
H	Batteria		1

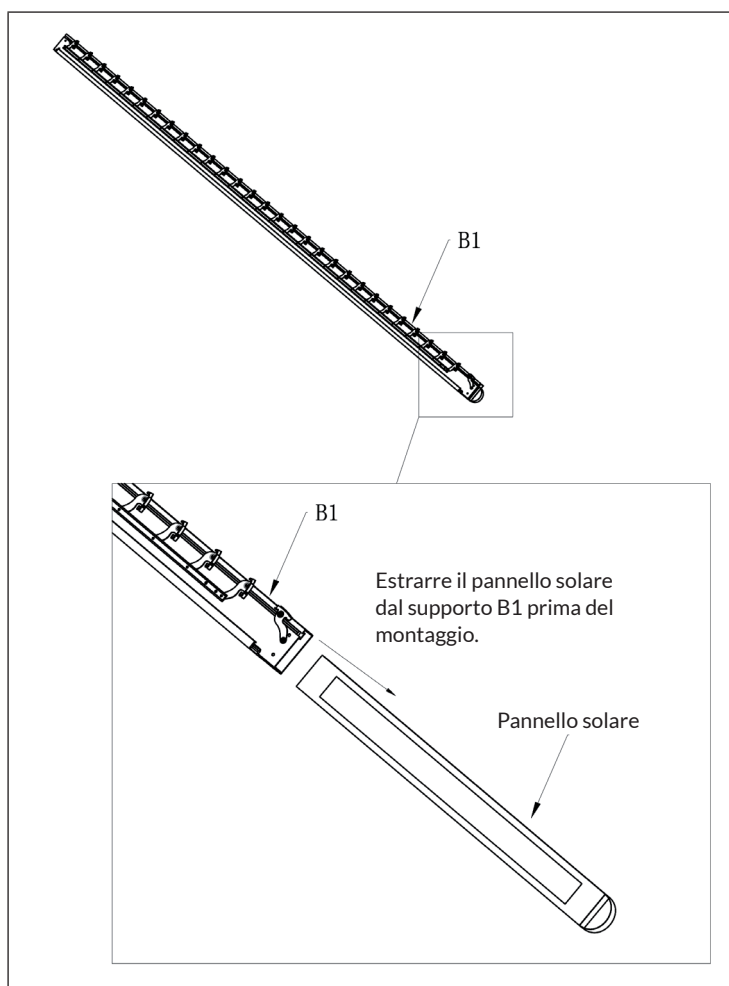

# MONTAGGIO

**Nota sulle indicazioni nelle immagini:** QTY=quantità/PCS=pezzi.

1

## Collegare il connettore di drenaggio alla colonna

Inserire il connettore di drenaggio (Q) nella fessura della colonna.  
Collegare poi il pannello di base della colonna (A) e stringere le viti.  
Eseguire questo passaggio per le 4 colonne.

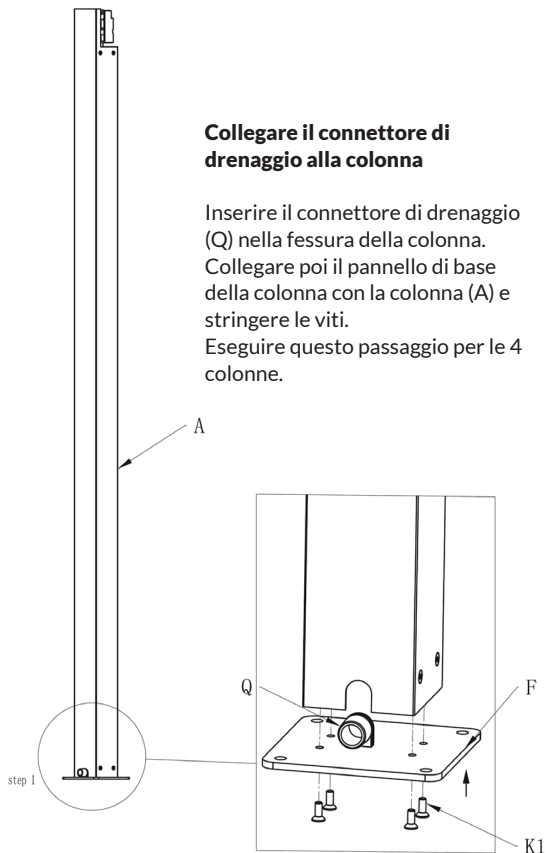

K1  QTY: 16 PCS

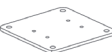
F  QTY: 4 PCS

Q  QTY: 4 PCS

Posizionare il connettore (H) su un lato della trave centrale (D). Procedere poi a stringere le viti (K1). Eseguire gli stessi passaggi sull'altro lato della trave.

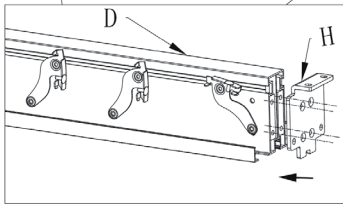
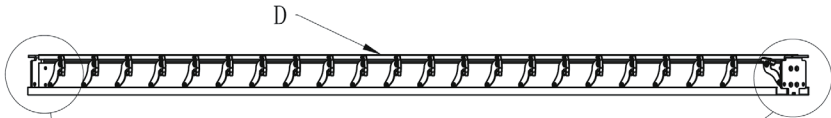

**Passo 1**

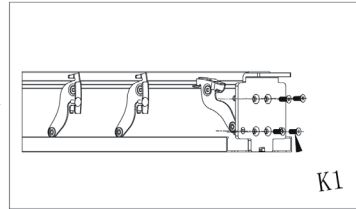

**Passo 2**

K1

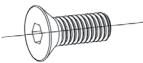

QTY:8PCS

H



QTY:2PCS

3

Inserire i due anelli incernierati (I) nell'albero di trasmissione sulla trave (D) e fissare gli anelli incernierati con una vite e un dado (K4) ciascuno.

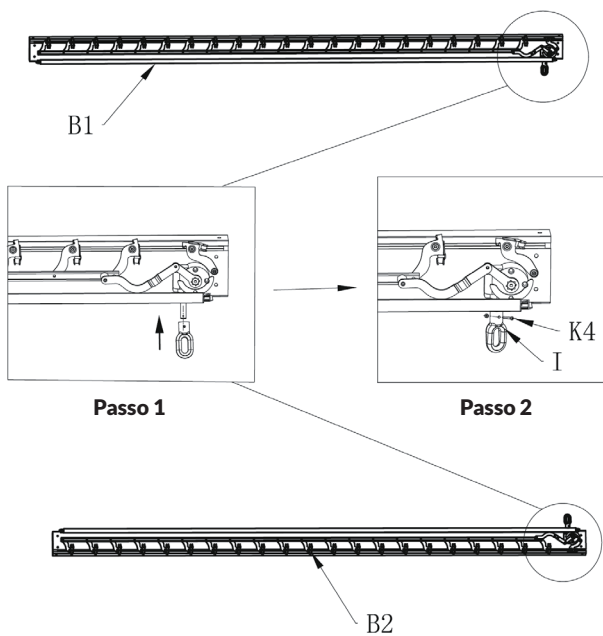

I

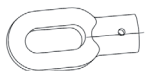

QTY:2PCS

K4

M4



M4x25

QTY:2 SETS

Posizionare le colonne e le travi come indicato in immagine e assicurarsi che il connettore di scarico delle colonne sia rivolto sempre verso lo stesso lato.

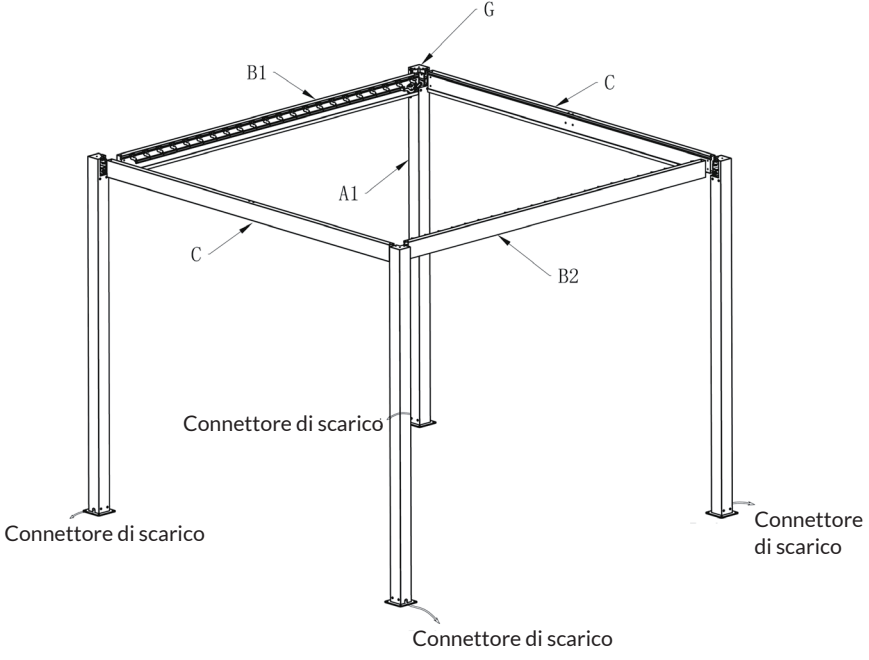



5

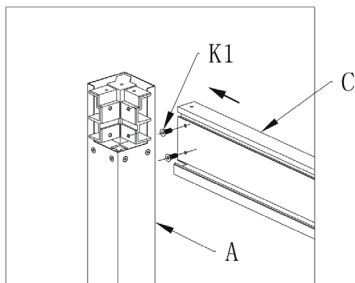

Posizionare entrambe le estremità delle travi anteriore e posteriore (C) sui rispettivi angolari di collegamento sulla colonna e stringere le viti (K1).

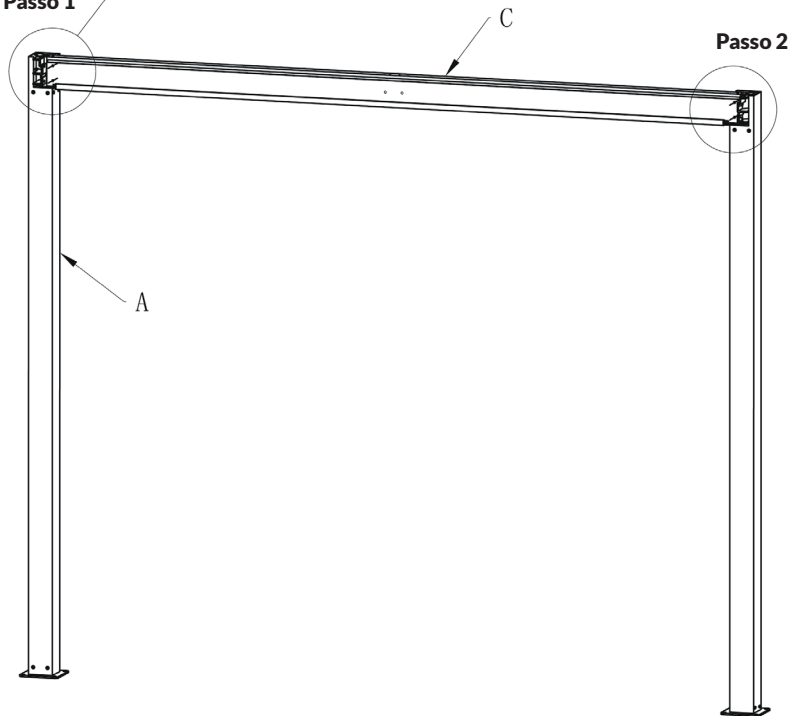
**Passo 1****Passo 2**

K1

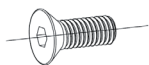

QTY:4PCS

Posizionare le travi destra e sinistra (B1&B2) sui rispettivi angolari di collegamento sulla colonna e fissarle con le viti (K1).

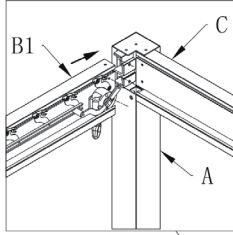

**Passo 1**

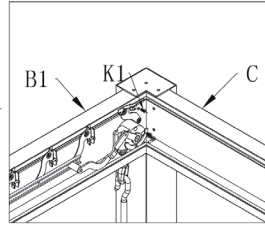

**Passo 2**

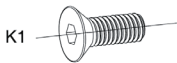
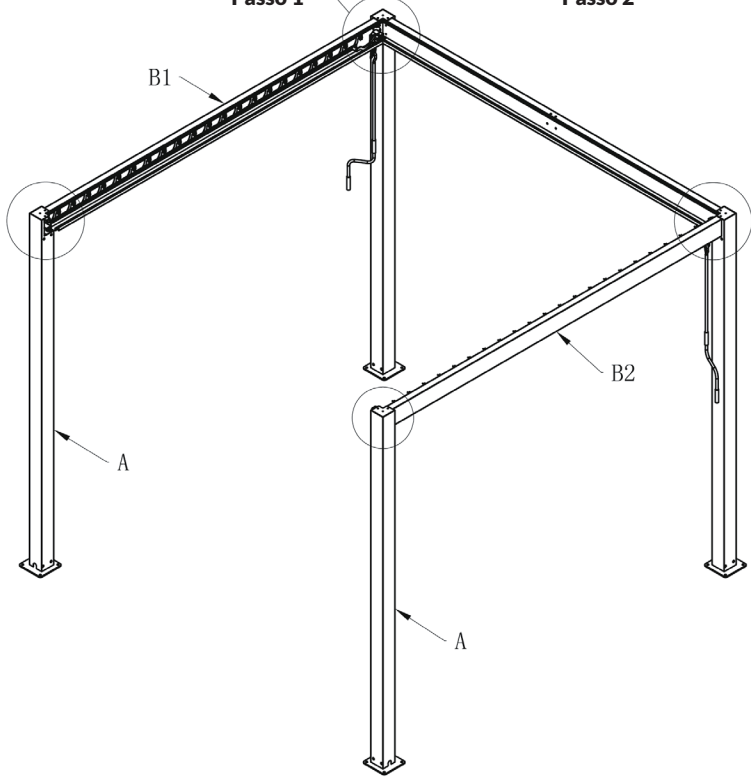

K1

QTY:8PCS

7

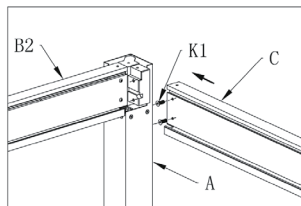

Posizionare le travi (C) sugli angolari di collegamento sulla colonna e fissare le travi con le viti (K1).

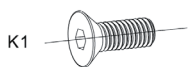
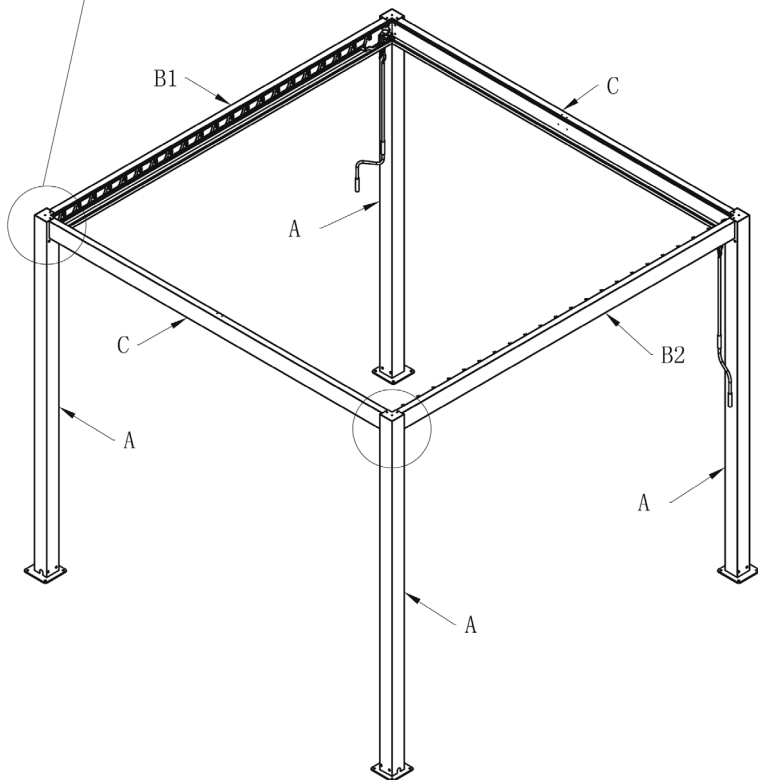

QTY:4PCS

8

Posizionare i 4 pannelli di copertura delle colonne (G) sugli angolari di collegamento della colonna e fissare i pannelli di copertura con le viti (K2).

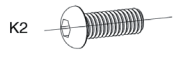
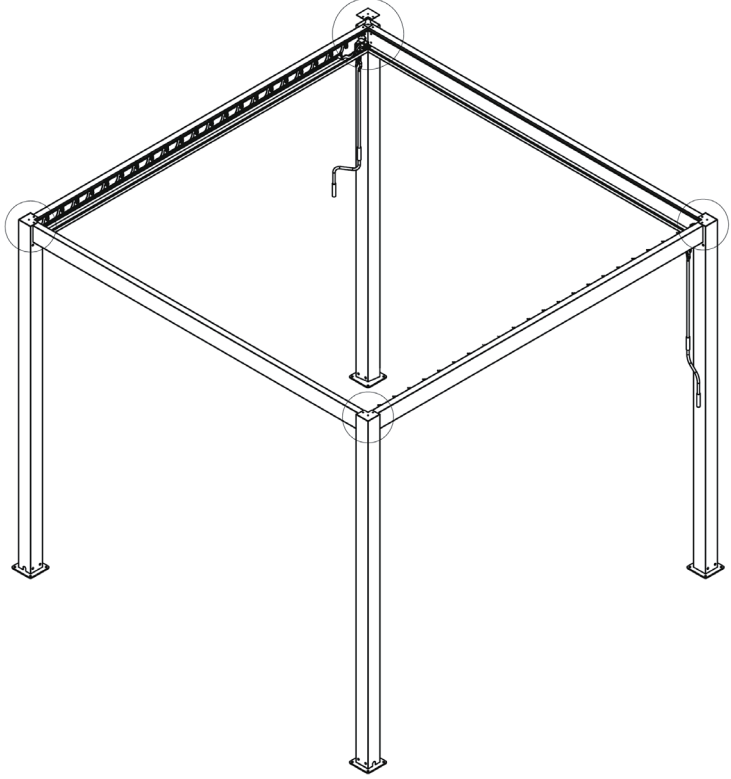
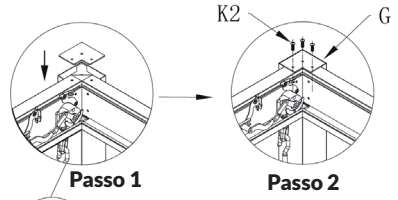

QTY:12PCS

G

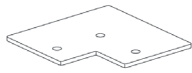

QTY:4PCS

9

Posizionare le 4 colonne in modo che siano perpendicolari al terreno. La distanza tra i bordi in alto e in basso deve essere uguale. Segnare poi con una matita 16 fori sul terreno, in modo che corrispondano ai fori nei pannelli di base.

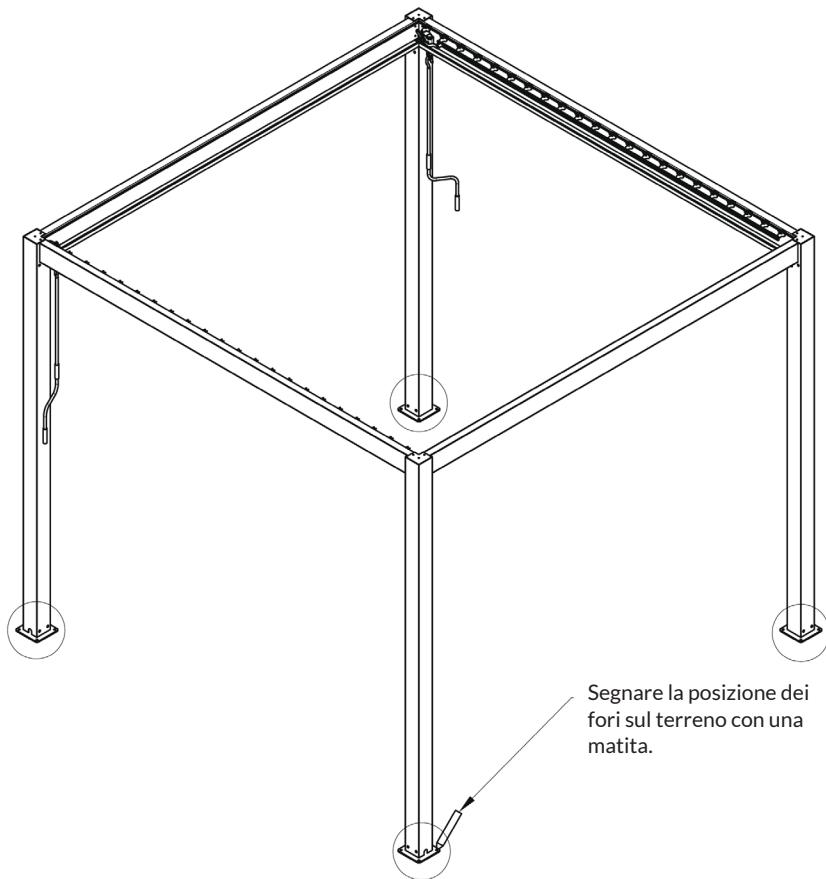

10

Spostare la colonna dal segno realizzato con la matita e, con l'ausilio di un trapano a percussione, realizzare fori di 10 mm di diametro e 80 mm di profondità sul terreno in corrispondenza delle 16 posizioni segnate in precedenza.

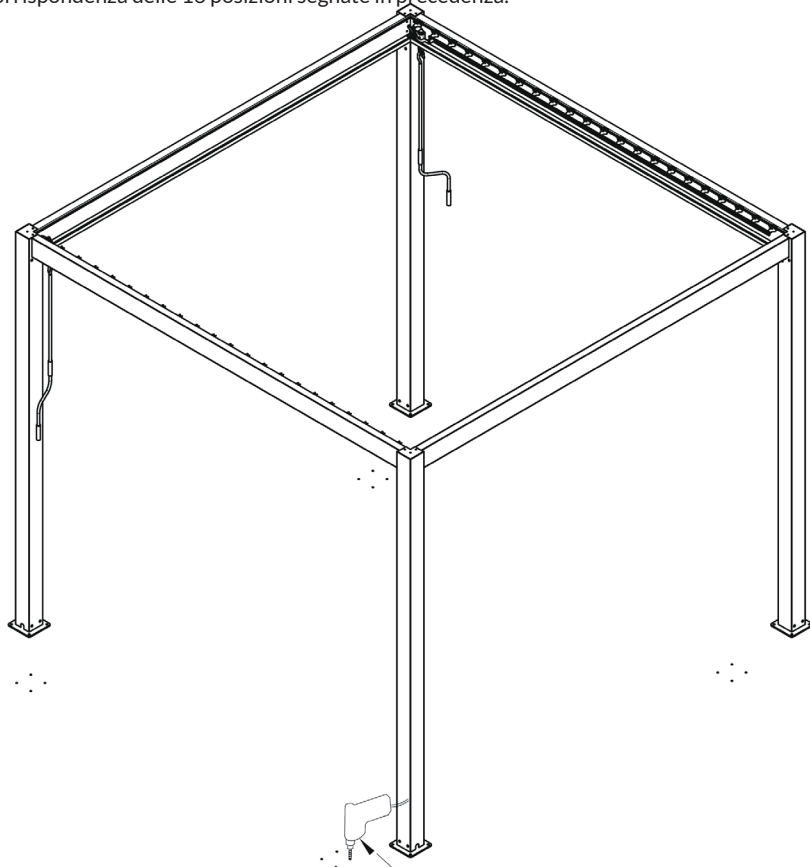

Realizzare un totale di 16 fori da 10 mm di diametro e 80 mm di profondità.

11

Inserire i tasselli nei fori sul terreno. Inserire la struttura nei fori e mettere i pannelli di base delle colonne in corrispondenza dei fori sul terreno. Fissare i pannelli di base delle colonne con 4 rondelle (K6) e 4 viti (L) ciascuno.

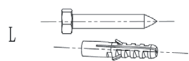
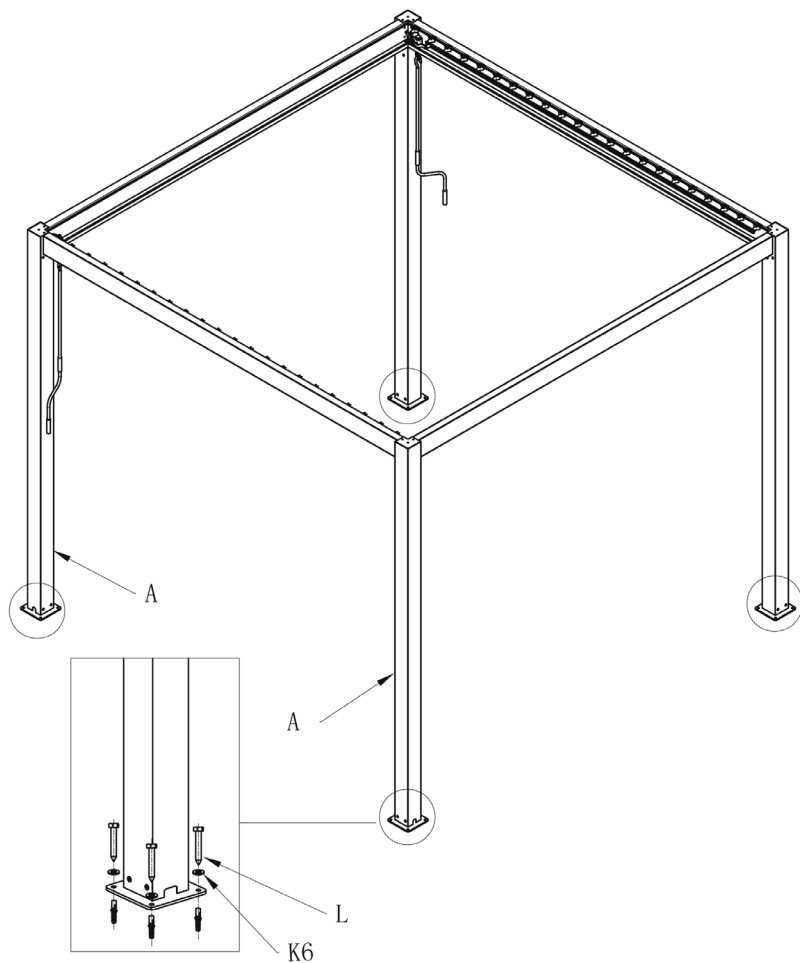

QTY: 16PCS

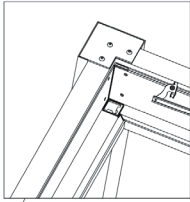

Applicare la colla per vetro (M) in modo omogeneo intorno al bordo della colonna e nelle fughe delle travi (v. immagine ingrandita).

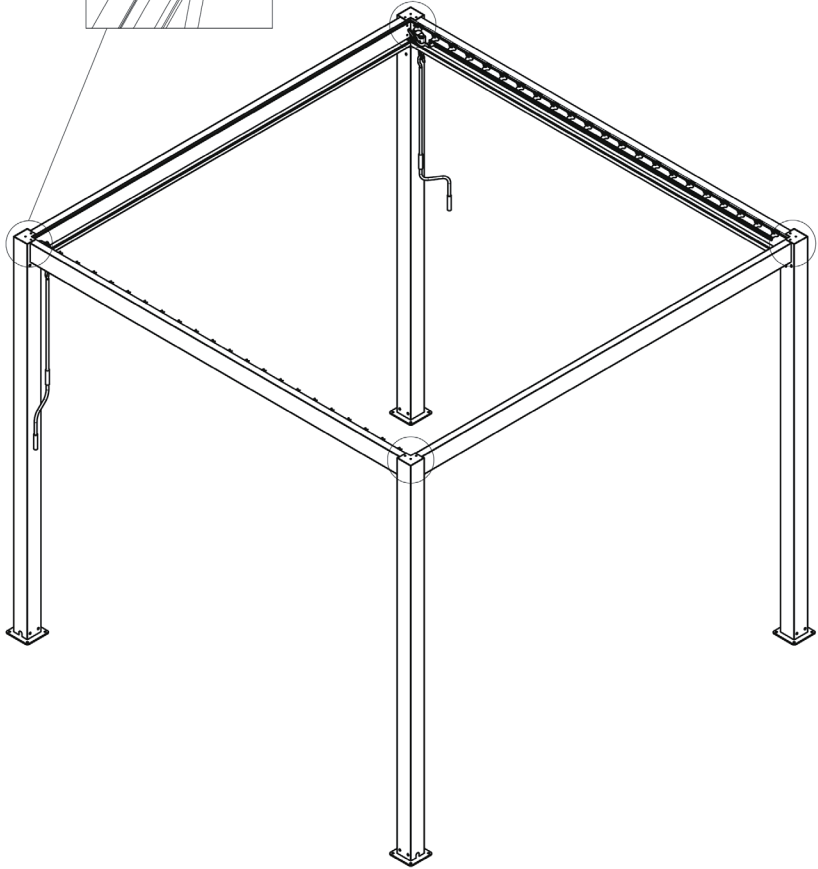

M



QTY: 1PC



13

Posizionare la trave centrale (D) sulle travi anteriore e posteriore (C).

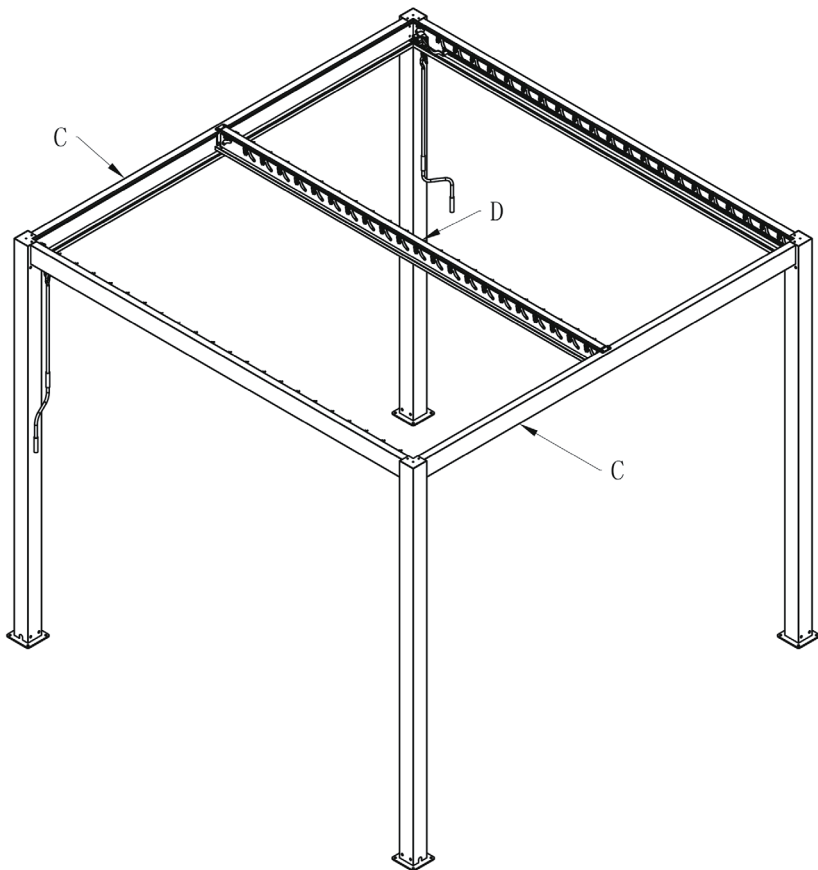

Posizionare 6 delle lamelle (E) all'estremità dei supporti su entrambi i lati delle travi (B1&B2) e premerle verso il basso per fissarle.

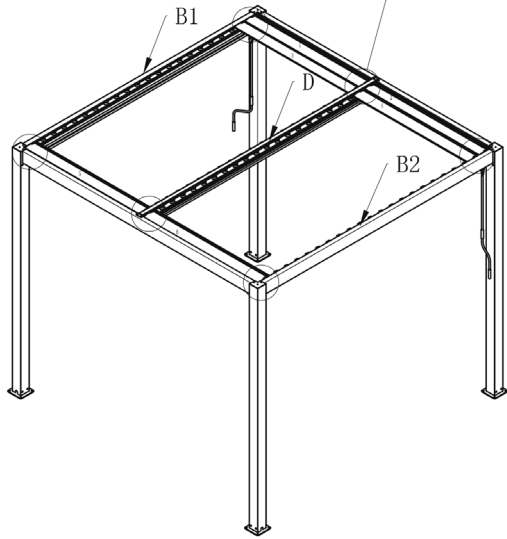
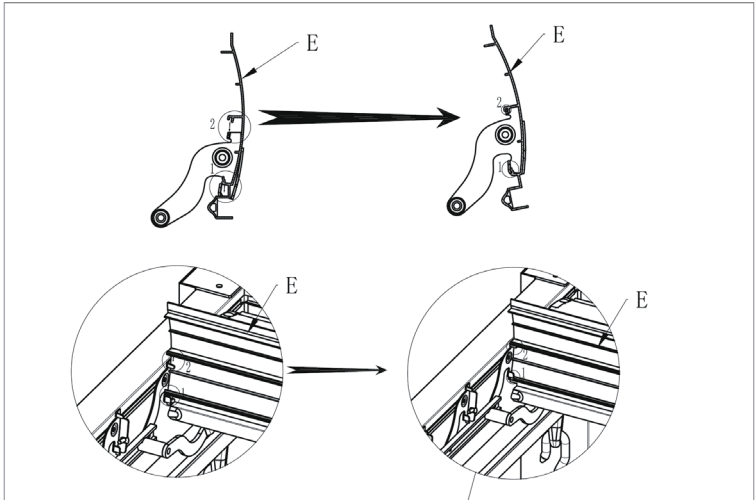

15

Fissare prima la vite (K2) con la rondella (K3) nel foro sotto alla trave (D). Ripetere questo passaggio anche per la trave (C). Inserire poi le altre lamelle seguendo l'ordine.

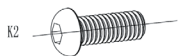
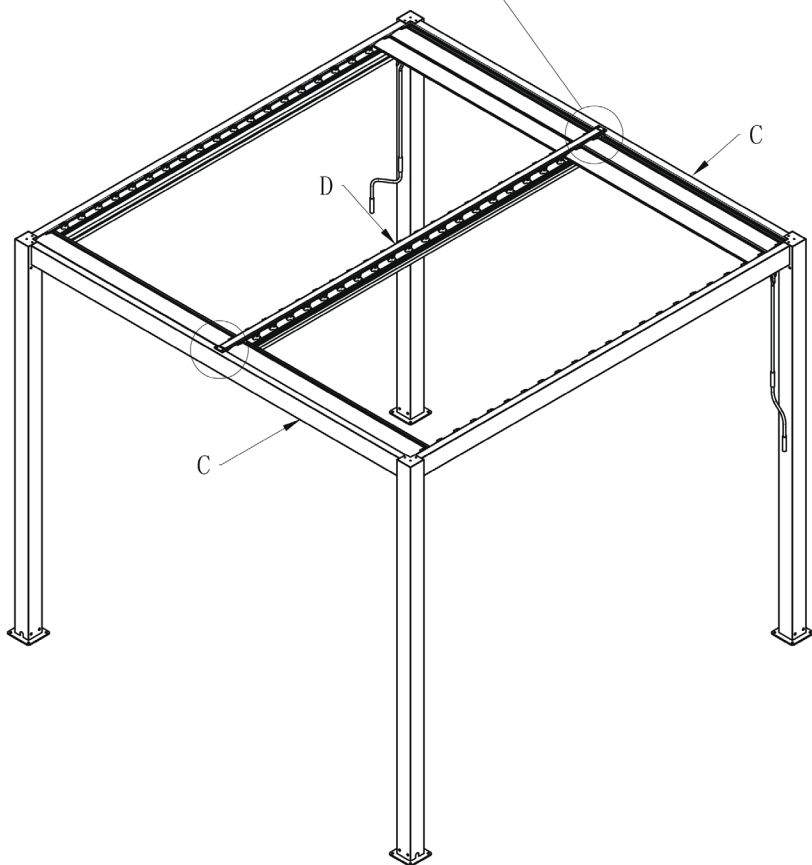
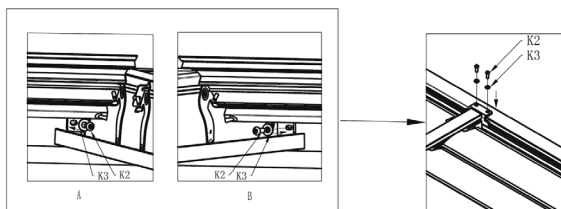

QTY: 8PCS



QTY: 8PCS

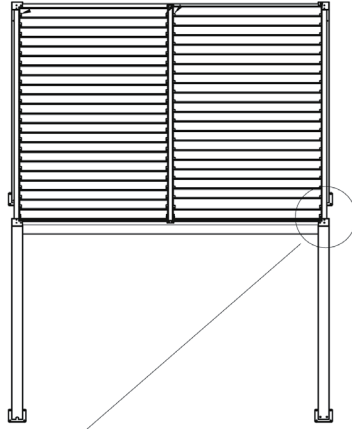

Regolare il gazebo seguendo questi passaggi, se non è possibile chiuderlo completamente.

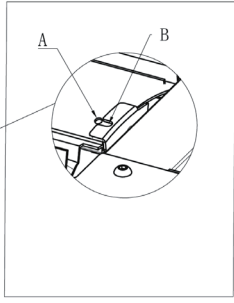
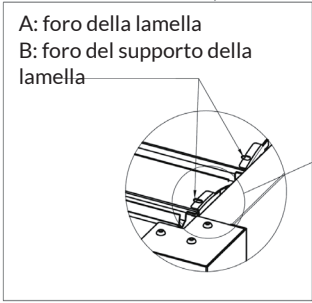

Regolare l'installazione come indicato di seguito, se foro A e foro B non sono in corrispondenza:



Regolare il supporto delle lamelle (B) con un cacciavite dritto.



I fori A e B devono essere in corrispondenza dopo la regolazione.

Posizionare la copertura in plastica (N) su entrambi i lati di ogni lamella.

L'immagine indica come posizionare la copertura in plastica (N) nella prima lamella anteriore.

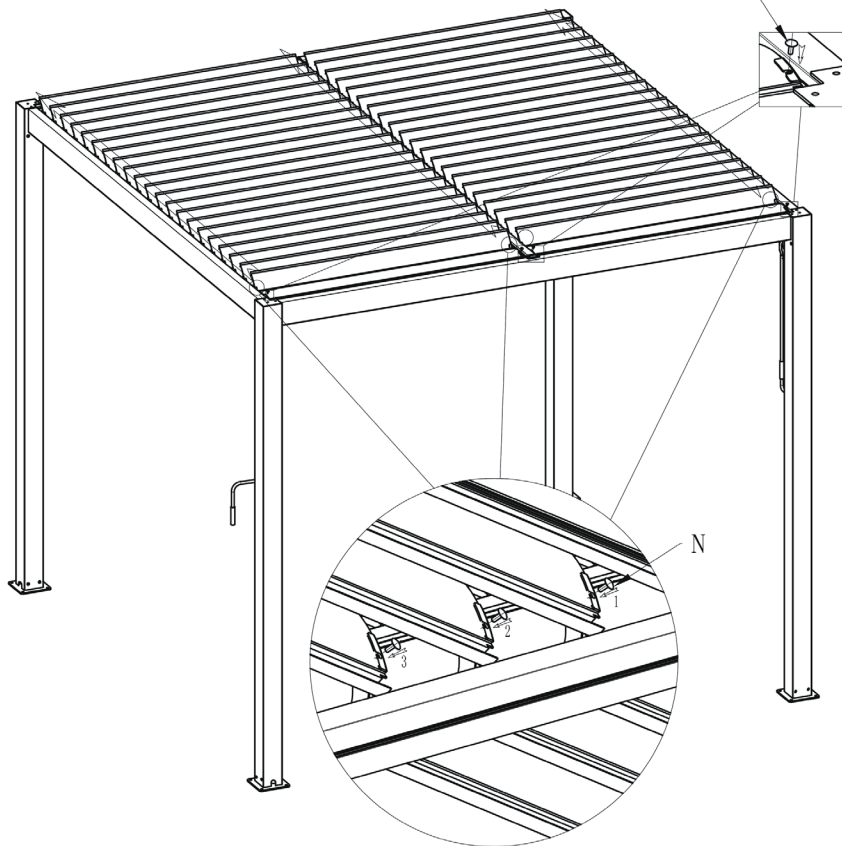

Girare le lamelle in posizione intermedia e inserire le coperture in plastica (N) una dopo l'altra nei fori su entrambe le estremità di ogni lamella.

Infine, fissare le due manovelle (J) per aprire e chiudere le lamelle.  
L'installazione del gazebo è conclusa.

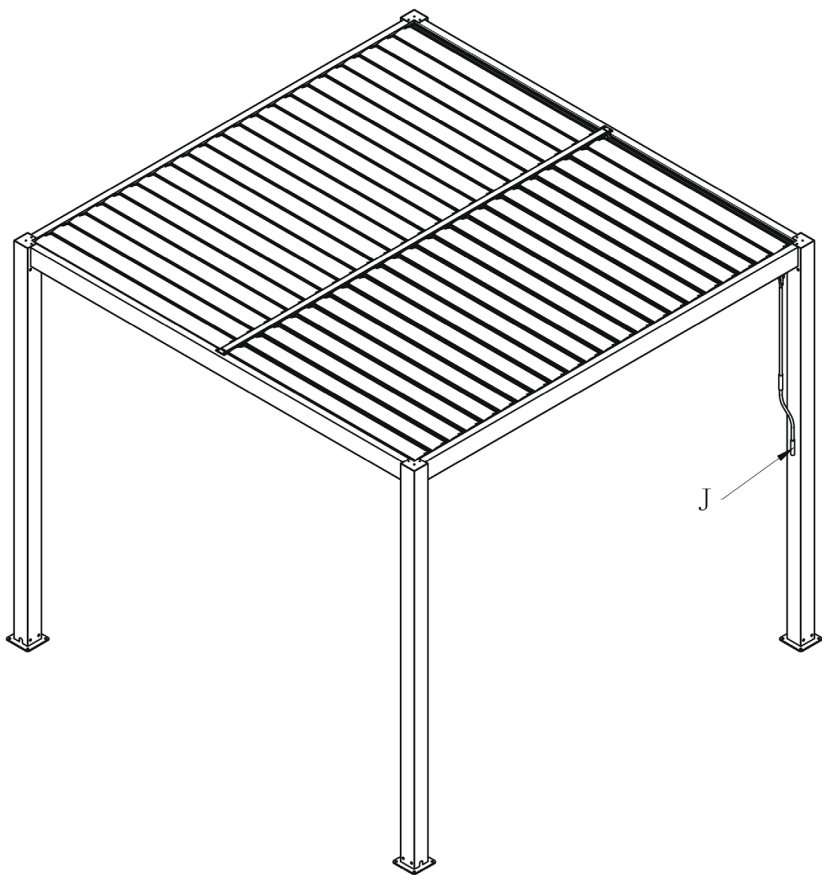

**2° passaggio:** fissare l'estremità maschio (M) della trave (B1) e l'estremità femmina (W) della trave (C) all'alimentatore separatamente. Stingere poi i tappi a vite all'estremità dei cavi della luce.

**3° passaggio:** fissare l'alimentatore alla trave (C) con le viti (K5). Impostare il colore della luce in base all'illuminazione con il telecomando (P).

**1° passaggio:** collegare l'estremità (M) del cavo della luce della trave (B2) con l'estremità (W) del cavo della luce della trave (C) e girare poi il tappo a vite per fissarlo. Ad eccezione del punto di collegamento delle travi (B1) e (C), gli altri cavi della luce devono essere collegati in modo analogo in senso orario.

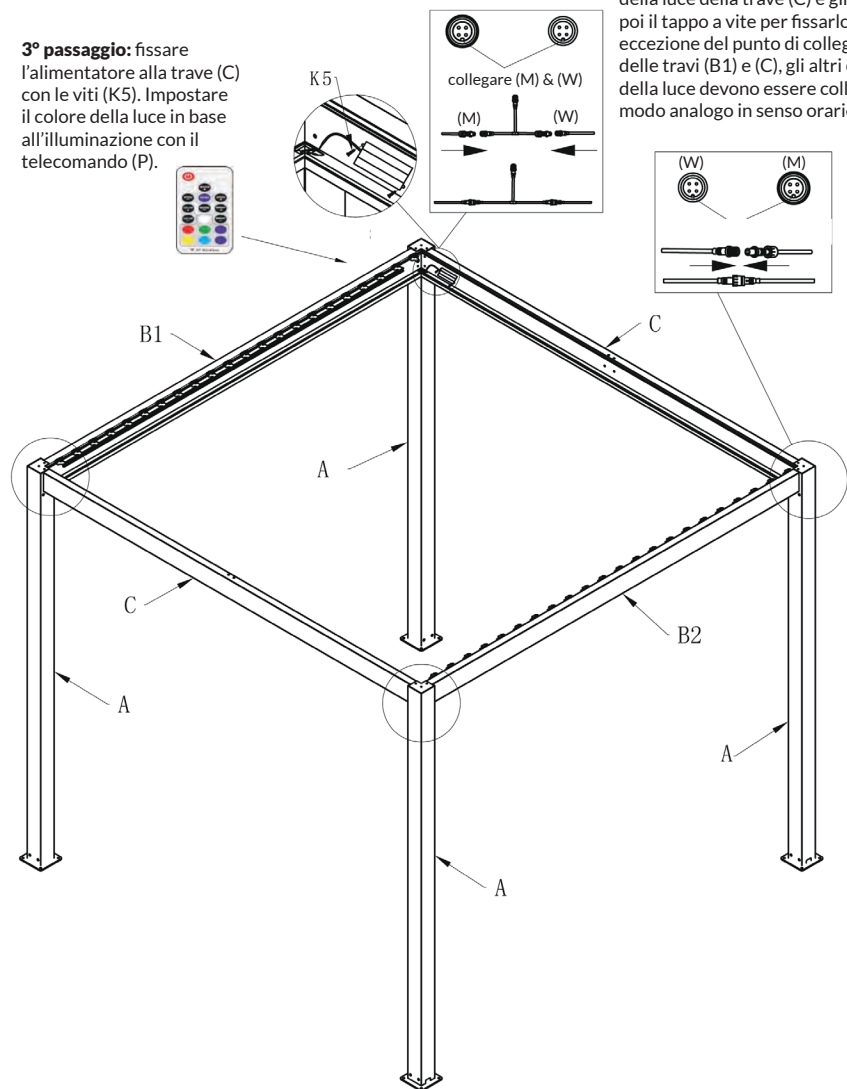

P



QTY: 1PCS

K5



QTY: 2PCS

## INSTALLAZIONE DEL PANNELLO SOLARE

21

**2° passaggio:** collegare i supporti (S) con (K9) e (K10) e fissare i supporti (S) con le viti (K8) al pannello solare.

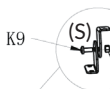
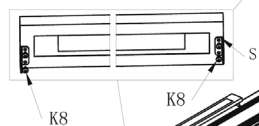

K10

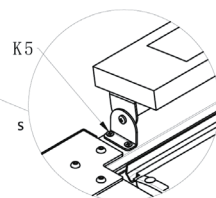

**3° passaggio:** fissare i supporti (S) con le viti (K5) alla trave..

A

**1° passaggio:** fissare il supporto (R) con la vite (K5) alla trave (A) e inserire poi le batterie nel supporto.

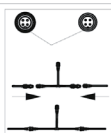
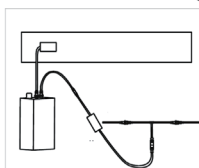
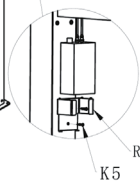

R



QTY: 1PCS

K5



QTY: 6PCS

K8



QTY: 4PCS

S



QTY: 4PCS

K9



QTY: 2PCS

K10



QTY: 2PCS



## AVVERTENZE INERENTI LA BATTERIA AGLI IONI DI LITIO

### Specifica

Tensione nominale	11,1 V
Potenza nominale	10 Ah
Ingresso	12,6 V / 3 A max.
Uscita	12 V (9 - 12,6 V) / 6 A max.
Dimensioni	158 x 90 x 60 mm (alloggiamento)
Peso	0,8 kg

### Descrizione del dispositivo

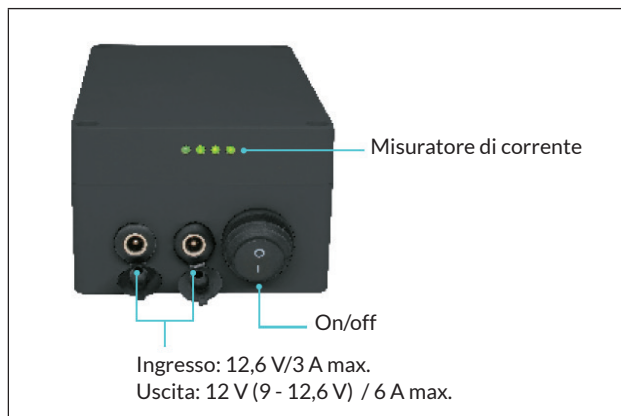

### **Avvertenze di sicurezza**

- Prestare molta attenzione quando si utilizza il dispositivo. Non farlo cadere o rovesciarlo. Non tentare di smontare il dispositivo.
- Non utilizzare il dispositivo in luoghi umidi o in acqua. Utilizzare il dispositivo in luoghi asciutti e ben ventilati.
- Il dispositivo contiene una batteria agli ioni di litio. Tenere il dispositivo lontano da fonti di calore.
- Quando non si usa il dispositivo per un lungo periodo di tempo, si consiglia di ricaricare la batteria ogni 3 mesi per non comprometterne la durata.
- Ricaricare la batteria solo con un cavo conforme alle norme.
- In caso di malfunzionamenti rivolgersi al produttore o al servizio di assistenza ai clienti.

### **Avvertenze per la ricarica**

1. Il dispositivo deve essere usato esclusivamente con il caricabatterie da 12,6 V configurato dal produttore e può essere ricaricato tramite il connettore DC.
2. Non utilizzare altri caricabatterie per ricaricare la batteria.
3. Quando la spia del dispositivo è rossa, significa che la ricarica è ancora in corso.
4. Quando la spia del caricabatterie è verde o blu, significa che la ricarica si è conclusa oppure che non sta ricaricando. Togliere la spina del caricabatterie dalla presa elettrica quando si è ricaricato completamente.
5. Quando la spia del modulo di ricarica solare lampeggia di rosso, significa che non sta ricaricando. Quando la spia è arancione, significa che la ricarica è in corso. Quando la spia è verde, significa che la batteria è completamente carica.

## UTILIZZO DEL TELECOMANDO

### Funzioni

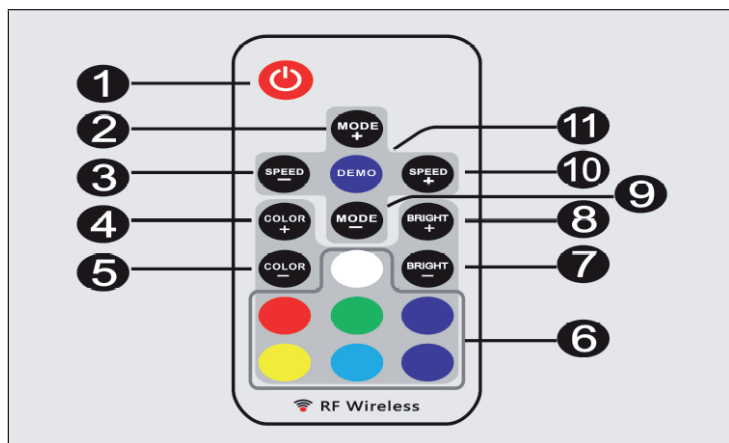

1	On/Standby
	Premere questo tasto per accendere il dispositivo o metterlo in standby. All'accensione viene ripristinato lo stato precedente.
2/9	Regolazione della modalità dinamica
	Premere questo tasto per passare dalla modalità statica a quella dinamica cromatica oppure da una modalità dinamica all'altra.
3/10	Regolazione dinamica della velocità
	Premere il tasto SPEED+ per aumentare la velocità e SPEED- per ridurla. Quando si preme il tasto in modalità statica, il dispositivo passa in modalità dinamica.
4/5	Regolazione statica cromatica
	Premere questo tasto per passare dalla modalità dinamica cromatica a quella statica oppure per passare da un colore statico all'altro.

6	Selezione cromatica diretta
	Premere questo tasto per entrare direttamente nella selezione statica cromatica. Quando si preme un determinato tasto cromatico, si accende il LED del colore corrispondente. Con i tasti COLOR+ e COLOR- si può selezionare direttamente il colore.
7/8	Regolazione della luminosità
	Regolazione della luminosità dei colori statici. Premere il tasto BRIGHT+ per aumentare la luminosità e BRIGHT- per diminuirla. Quando si preme il tasto in modalità dinamica, il dispositivo passa automaticamente in modalità statica cromatica.
11	Modalità demo
	Quando si preme questo tasto si accede alla modalità demo. In modalità demo vengono riprodotte 17 modalità dinamiche in loop e ogni modalità viene ripetuta tre volte.

---

## INSTALLAZIONE DEL LED CONTROLLER

---

### Alimentazione

Per questo dispositivo si può usare un'alimentazione tra DC 5 V e 24 V. Il polo interno (o il cavo rosso) della spina DC è positivo e la boccola (o il cavo nero) è negativa. Assicurarsi che la tensione di rete corrisponda alla tensione del LED.

### Uscita LED

Il dispositivo supporta i tradizionali prodotti LED con collegamento dell'anodo. Il simbolo [A] mostra il nodo di collegamento in comune.

La corrente di picco in uscita è di 4 ampere e la corrente continua massima è di 2 ampere per ogni canale. Si prega di ridurre il carico quando il dispositivo principale si surriscalda.

**Nota:** le uscite LED non devono essere messe in cortocircuito oppure sovraccaricate. Ciò può causare danni permanenti!

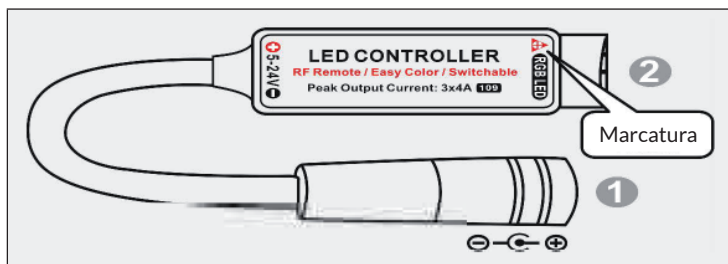

### Utilizzo con il telecomando

Prima dell'utilizzo rimuovere il nastro isolante dalla batteria. Il segnale wireless del telecomando attraversa le barriere. Per questo motivo non è necessario puntare il telecomando in direzione del dispositivo principale. Per garantire una ricezione perfetta del segnale del telecomando, non installare il dispositivo principale in un alloggiamento di metallo chiuso.

### Accoppiare un nuovo telecomando

Il telecomando e l'unità principale sono accoppiati di default. E' possibile accoppiare l'unità principale con altri 3 telecomandi. Eseguire i seguenti passaggi per accoppiare un nuovo telecomando:

1. Spegner il dispositivo principale, staccare la spina dalla presa e aspettare 5 secondi. Reinserire la spina nella presa e riaccendere il dispositivo principale.
2. Premere contemporaneamente i tasti [COLOR-] e [BRIGHT-] entro 5 secondi dall'accensione.

Dopo questa operazione, il dispositivo principale riconosce il nuovo telecomando.

### **Modalità di accoppiamento libero del telecomando**

In alcuni casi particolari bisogna accoppiare il dispositivo principale con qualsiasi telecomando.

1. Spegnerne il dispositivo principale, staccare la spina dalla presa e aspettare 5 secondi. Reinscrivere la spina nella presa e riaccendere il dispositivo principale.
2. Premere contemporaneamente i tasti [ON/STANDBY] e [MODE+] entro 5 secondi dall'accensione.

Dopo questa operazione, il dispositivo principale riconosce tutti i telecomandi disponibili. Per accoppiare il dispositivo principale con un determinato telecomando, ripetere il procedimento "Accoppiare un nuovo telecomando".

### **Regolare la sequenza dei colori di base**

La sequenza standard dei colori di base del controller è verde-rosso-blu. Se i tasti colorati non corrispondono al colore del LED, regolare la sequenza dei colori di base nel modo seguente:

1. Spegnerne il dispositivo principale, staccare la spina dalla presa e aspettare 5 secondi. Reinscrivere la spina nella presa e riaccendere il dispositivo principale.
2. Premere contemporaneamente i tasti [ROSSO] e [BLU] entro 5 secondi dall'accensione.

Con questa operazione la sequenza iniziale passa per 6 possibili combinazioni. Le 6 combinazioni vengono salvate e attivate al prossimo spegnimento e all'accensione.

---

## AVVISO DI SMALTIMENTO

---



Se nel proprio paese si applicano le regolamentazioni inerenti lo smaltimento di dispositivi elettrici ed elettronici, questo simbolo sul prodotto o sulla confezione segnala che questi prodotti non possono essere smaltiti con i rifiuti normali e devono essere portati a un punto di raccolta di dispositivi elettrici ed elettronici. Grazie al corretto smaltimento dei vecchi dispositivi si tutela il pianeta e la salute delle persone da possibili conseguenze negative. Informazioni riguardanti il riciclo e lo smaltimento di questi prodotti si ottengono presso l'amministrazione locale oppure il servizio di gestione dei rifiuti domestici.

Il prodotto contiene batterie. Se nel proprio paese si applicano le regolamentazioni inerenti lo smaltimento di batterie, non possono essere smaltite con i normali rifiuti domestici. Preghiamo di informarvi sulle regolamentazioni vigenti sullo smaltimento delle batterie. Grazie al corretto smaltimento dei vecchi dispositivi si tutela l'ambiente e la salute delle persone da conseguenze negative.

---

## PRODUTTORE E IMPORTATORE (UK)

---

**Produttore:**

Chal-Tec GmbH, Wallstraße 16, 10179 Berlino, Germania.

**Importatore per la Gran Bretagna:**

Berlin Brands Group UK Ltd  
PO Box 1145  
Oxford, OX1 9UW  
United Kingdom







