

# ABERDEEN DOUBLE

Holzkohlegrill  
Charcoal Grill  
Barbecue au charbon de bois  
Parrilla de carbón  
Griglia a carbonella

10040293



COOKINGCO  
OOKINGCOO  
KINGCOOKIN  
INGCOOKING  
COOKINGCO  
OOKINGCOO  
KINGCOOKIN  
INGCOOKING

**KLARSTEIN**

[www.klarstein.com](http://www.klarstein.com)



**Sehr geehrter Kunde,**

wir gratulieren Ihnen zum Erwerb Ihres Gerätes. Lesen Sie die folgenden Hinweise sorgfältig durch und befolgen Sie diese, um möglichen Schäden vorzubeugen. Für Schäden, die durch Missachtung der Hinweise und unsachgemäßen Gebrauch entstehen, übernehmen wir keine Haftung. Scannen Sie den folgenden QR-Code, um Zugriff auf die aktuellste Bedienungsanleitung und weitere Informationen rund um das Produkt zu erhalten.



---

**INHALTSVERZEICHNIS**

---

Sicherheitshinweise 4  
Geräteübersicht 6  
Lieferumfang 7  
Teileliste 8  
Bedienung 10  
Reinigung und Pflege 11  
Montageanleitung 53

English 13  
Français 23  
Español 33  
Italiano 43

---

**HERSTELLER & IMPORTEUR (UK)**

---

**Hersteller:**

Chal-Tec GmbH, Wallstraße 16, 10179 Berlin, Deutschland.

**Importeur für Großbritannien:**

Berlin Brands Group UK Limited  
PO Box 42  
272 Kensington High Street  
London, W8 6ND  
United Kingdom

## SICHERHEITSHINWEISE



### GEFAHR

Erstickungsgefahr! Verwenden Sie das Gerät keinesfalls in geschlossenen Räumen, wie beispielsweise Häusern, Fahrzeugen oder Zelten. Andernfalls kann dies, durch das bei der Verbrennung der Kohle entstehende, geruchlose Kohlenstoffmonoxid, zum Tode führen.

- Bewahren Sie diese Bedienungsanleitung an einem sicheren Ort auf.
- Lesen Sie sich die Hinweise zum Entzünden des Holzkohlegrills aufmerksam durch, bevor Sie das Gerät verwenden.

Die Nichtbeachtung dieser Sicherheitshinweise und Vorsichtsmaßnahmen kann zu schweren Verletzungen führen. Lesen Sie die folgenden Anweisungen, bevor Sie Ihren Grill benutzen.

- Dieser Grill darf nur im Freien und niemals in Innenräumen verwendet werden.
- Stellen Sie den Grill vor der Benutzung auf einer möglichst windgeschützten, ebenen Fläche auf, möglichst weit weg von Überhängen und Bäumen.
- Halten Sie einen Sicherheitsabstand von 1,5 Metern zu brennbaren Materialien ein.
- Verwenden Sie keine Flüssigkeiten wie Benzin oder ähnliche leicht entzündliche Flüssigkeiten zum Anzünden oder Anfachen des Grills oder zum Anfeuern der warmen oder heißen Holzkohle!
- Lassen Sie den heißen Grill oder heiße Kohlen und Asche nicht unbeaufsichtigt.
- Die maximale Menge an Briketts für diese Grills beträgt 1 kg für jede Seite der Grillschale.
- Folgen Sie sorgfältig den Anweisungen auf dem Brennmaterialbeutel.
- Setzen Sie den Deckel nicht auf den Grill, bevor die Flamme erloschen ist.
- Verwenden Sie den Grill erst dann zur Zubereitung von Lebensmitteln, wenn die Kohle mit einer Ascheschicht bedeckt ist.
- Die Holzkohle wird sehr heiß. Treffen Sie geeignete Vorsichtsmaßnahmen.
- Tragen Sie hitzebeständige Ofenhandschuhe, wenn Sie grillen oder die Belüftungsöffnungen einstellen.
- Legen Sie beim Löschen der Holzkohle den Deckel auf die Schale und schließen Sie gegebenenfalls alle Lüftungsöffnungen.
- Entfernen Sie die Asche erst dann, wenn die Holzkohle vollständig abgebrannt und erloschen ist.
- Entfernen Sie die Asche vor dem nächsten Grillen. Achten Sie darauf, dass die Asche bei der Entnahme kalt ist.
- Halten Sie Kinder und Haustiere jederzeit vom Grill fern.



### VORSICHT

Verletzungsgefahr! Der Grill wird sehr heiß, bewegen Sie ihn nicht während des Betriebs. Lassen Sie das Gerät vollständig abkühlen, bevor Sie es bewegen oder lagern.

⚠		
	 ❌	 ❌
	 ❌	 ✅

**VORSICHT!**  
VERWENDEN SIE KEINEN SPIRITUS  
ODER BENZIN ZUM ANZÜNDEN ODER  
WIEDERANZÜNDEN!



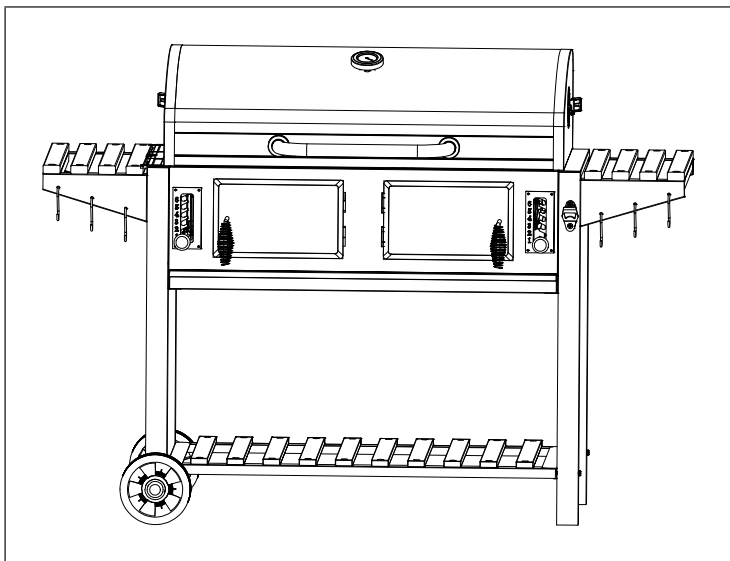



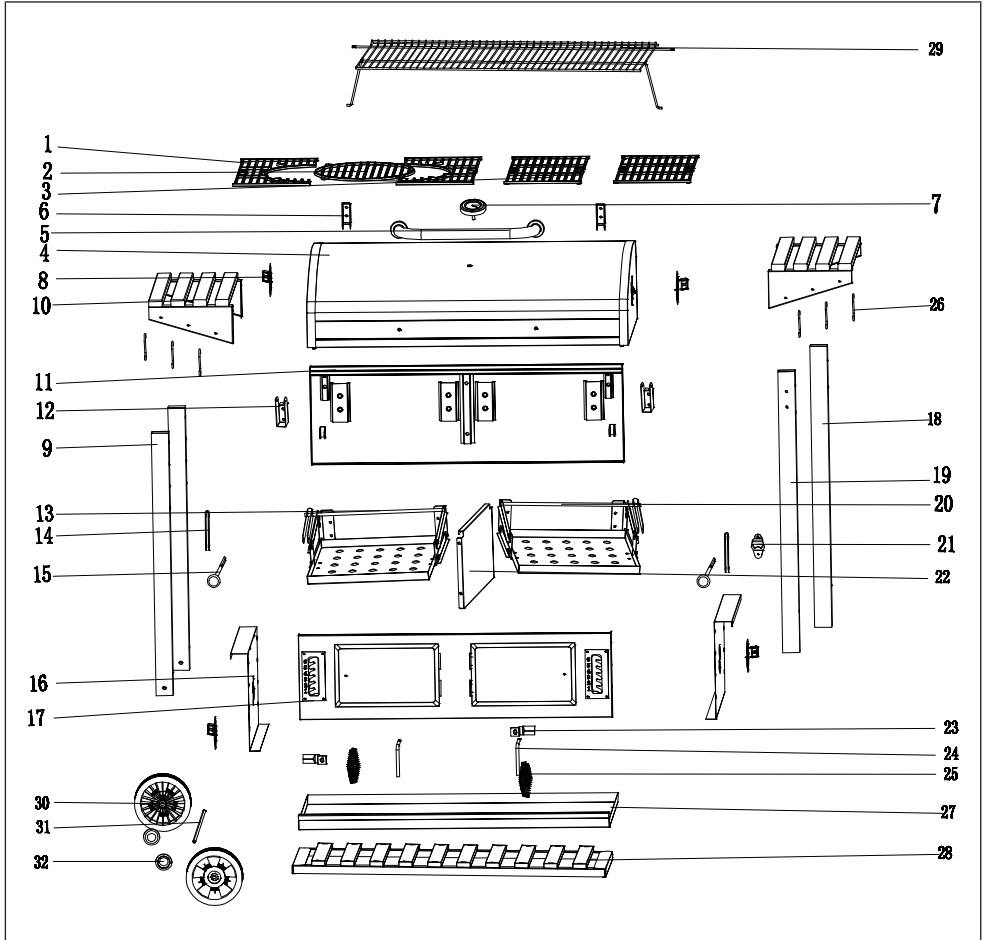

























# GERÄTEÜBERSICHT



## LIEFERUMFANG



## TEILELISTE

1.		X 2	21.		X 1
2.		X 1	22.		X 1
3.		X 2	23.		X 2
4.		X 1	24.		X 2
5.		X 1	25.		X 2
6.		X 2	26.		X 6
7.		X 1	27.		X 1
8.		X 4	28.		X 1
9.		X 2	29.		X 1
10.		X 2	30.		X 2
11.		X 1	31.		X 1
12.		X 2	32.		X 2
13.		X 1			
14.		X 2			
15.		X 2			
16.		X 2			
17.		X 1			
18.		X 1			
19.		X 1			
20.		X 1			



A.  (M6x12mm) X 44

---

B.  (M6x60mm) X 4

---

C.  (M6x40mm) X 8

---

D.  X 10

---

E.  X 2

---

F.  X 2

---

G.  X 6

---

H.  (M6x25mm) X 2

---

I.  X 16

---

J.  X 2

---

---

---

---

---

---

---

---

---

---

---

---

---

---

---

---

---

---

---

---

---

---

## BEDIENUNG

---

### Hinweise zur Verwendung

- Verwenden Sie den Grill erst dann zur Zubereitung von Lebensmitteln, wenn die Kohle mit einer Ascheschicht bedeckt ist.
- Bewegen Sie den Grill nicht während dessen Verwendung.
- Verwenden Sie den Grill keinesfalls in Innenräumen.
- Verwenden Sie zum Entzünden oder Anfachen kein Benzin oder Brennspritus.
- Halten Sie Kinder und Haustiere jederzeit vom Grill fern.
- Platzieren Sie den Grill in einer stabilen Position auf einer ebenen Oberfläche.

### Vorbereitung

- Bevor Sie mit Ihrem Grill Lebensmittel zubereiten, sollten Sie die folgenden Schritte genau befolgen, um sowohl die Lackierung zu versiegeln als auch den Innenstahl zu schützen. Wenn Sie diese Schritte nicht befolgen, kann die Oberfläche beschädigt werden und Ihre Speisen können einen metallischen Geschmack annehmen.
- Streichen Sie alle Innenflächen, einschließlich der Grillroste, mit pflanzlichem Speiseöl ein.
- Machen Sie ein kleines Feuer auf der Holzkohlepflanne und achten Sie darauf, dass die Kohlen nicht an den Wänden anliegen.
- Der Grill muss mindestens 30 Minuten vor dem ersten Grillen angezündet und die Glut gehalten werden.

### Geeignetes Brennmaterial

- Normale Briketts, Instant-Light-Briketts oder Holzkohle können als Brennstoffquelle für das Grillen verwendet werden. Verwenden Sie zum Anzünden von Briketts oder Holzkohle keine Anzünder auf Mineralölbasis oder dergleichen, da diese das Grillgut verderben können.
- Verwenden Sie keinen Anzündkamin für Instant-Light-Briketts.



#### **VORSICHT**

Verletzungsgefahr! Verwenden Sie keinen Spiritus oder Benzin zum Anzünden oder Wiederanzünden!

### Anzünden des Grills

- Stapeln Sie die Holzkohlebriketts oder die Holzkohle auf dem Holzkohlerost zu einer Pyramide.

**Feste Grillanzünder:** Legen Sie den Grillanzünder in die Basis der Pyramide. Zünden Sie den Grillanzünder an mehreren Stellen an, um ein gleichmäßiges Abbrennen zu gewährleisten.

**Flüssige oder Gel-Grillanzünder:** Bestreichen Sie die Briketts oder die Holzkohle mit der Flüssigkeit oder dem Gel und zünden Sie sie gemäß der Anweisungen des Herstellers an.

- Fügen Sie niemals Grillanzünder oder Ähnliches zu heißer oder warmer Kohle hinzu, da dies äußerst gefährlich sein kann.
- Verteilen Sie die Kohle, sobald das Feuer abgebrannt und die Kohle grau geworden ist, mit einem langstieligen Grillwerkzeug.
- Das Grillen kann nun beginnen!

**Hinweis:** Lassen Sie beim Umgang mit heißen Kohlen immer Vorsicht walten, um Verletzungen zu vermeiden.

---

## REINIGUNG UND PFLEGE

---

### Wartung

- Reinigen Sie die Grillschale mit Wasser und Seife.
- Verwenden Sie eine geeignete Abdeckung, um die Lebensdauer Ihres Grills zu verlängern.
- Lagern Sie den Grill an einem trockenen Ort.

### Reinigung

- Die Häufigkeit der Reinigung richtet sich danach, wie oft der Grill benutzt wird.
- Vergewissern Sie sich, dass die Kohlen vollständig erloschen sind, bevor Sie das Innere des Geräts reinigen.
- Spülen Sie das Gerät gründlich mit Wasser ab und lassen Sie es an der Luft trocknen, bevor Sie es wieder benutzen. Wischen Sie das Innere des Geräts mit einem Tuch oder Papiertüchern aus.
- Wenn Sie mit dem Grillen fertig sind und das Gerät ausreichend abgekühlt ist, entfernen Sie alle Aschereste. In der Asche sammelt sich Feuchtigkeit, die zu vorzeitigem Rosten und Verfall führen kann.
- An der Innenseite Ihres Grills kann sich Rost bilden. Ein leichter Anstrich mit Pflanzenöl auf den Innenflächen hilft, Ihren Grill zu schützen. Die Außenflächen des Grills müssen möglicherweise gelegentlich ausgebeißert werden. Es wird die Verwendung von handelsüblicher schwarzer Hochtemperaturfarbe empfohlen.

**Hinweis:** Streichen Sie niemals das Innere des Grills!



**Dear Customer,**

Congratulations on purchasing this device. Please read the following instructions carefully and follow them to prevent possible damages. We assume no liability for damage caused by disregard of the instructions and improper use. Scan the QR code to get access to the latest user manual and more product information.

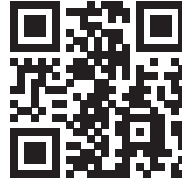

---

## CONTENTS

---

Safety Instructions 14  
Device Overview 16  
Scope of Delivery 17  
Parts List 18  
Operation 20  
Cleaning and Care 21  
Assembly Instructions 53

---

## MANUFACTURER & IMPORTER (UK)

---

**Manufacturer:**

Chal-Tec GmbH, Wallstrasse 16, 10179 Berlin, Germany.

**Importer for Great Britain:**

Berlin Brands Group UK Limited  
PO Box 42  
272 Kensington High Street  
London, W8 6ND  
United Kingdom

---

## SAFETY INSTRUCTIONS

---

**DANGER**

Danger of suffocation! Never use the device in closed rooms such as houses, vehicles or tents. Otherwise this can lead to death due to the odourless carbon monoxide produced when the coal is burned.

- Keep these operating instructions in a secure location.
- Read the instructions for lighting the charcoal grill carefully before using the device.

Failure to follow these safety instructions and precautions could result in serious injury. Read the following instructions before using your grill.

- This grill may only be used outdoors and never indoors.
- Before using the grill, set it up on a level surface that is as sheltered from the wind as possible and as far away from overhangs and trees as possible.
- Maintain a safety distance of 1.5 metres from combustible materials.
- Do not use liquids such as gasoline or similar flammable liquids to light or fan the grill, or to fuel warm or hot charcoal!
- Do not leave the hot grill or hot coals and ashes unattended.
- The maximum amount of briquettes for this grill is 1 kg for each side of the grill bowl.
- Carefully follow the instructions on the fuel bag.
- Do not place the lid on the grill until the flame has gone out.
- Do not use the grill to cook food until the charcoal is covered with a layer of ash.
- The charcoal gets very hot. Take appropriate precautions.
- Wear heat-resistant oven mitts when grilling or adjusting the vents.
- When extinguishing the charcoal, place the lid on the bowl and close any vents if necessary.
- Do not remove the ash until the charcoal is completely burned out and extinguished.
- Remove the ashes before grilling again. Make sure the ashes are cold when you remove them.
- Keep children and pets away from the grill at all times.

**CAUTION**

Risk of injury! The grill gets very hot, do not move it during operation. Let the device cool down completely before moving or storing it.



## DEVICE OVERVIEW

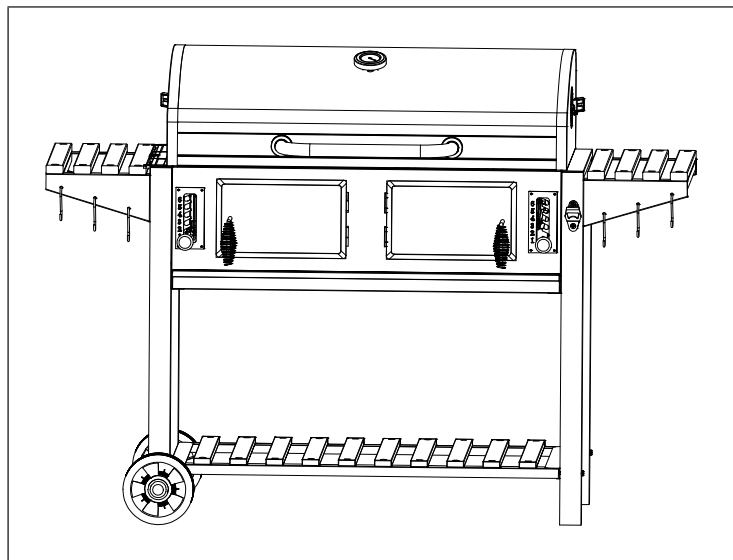





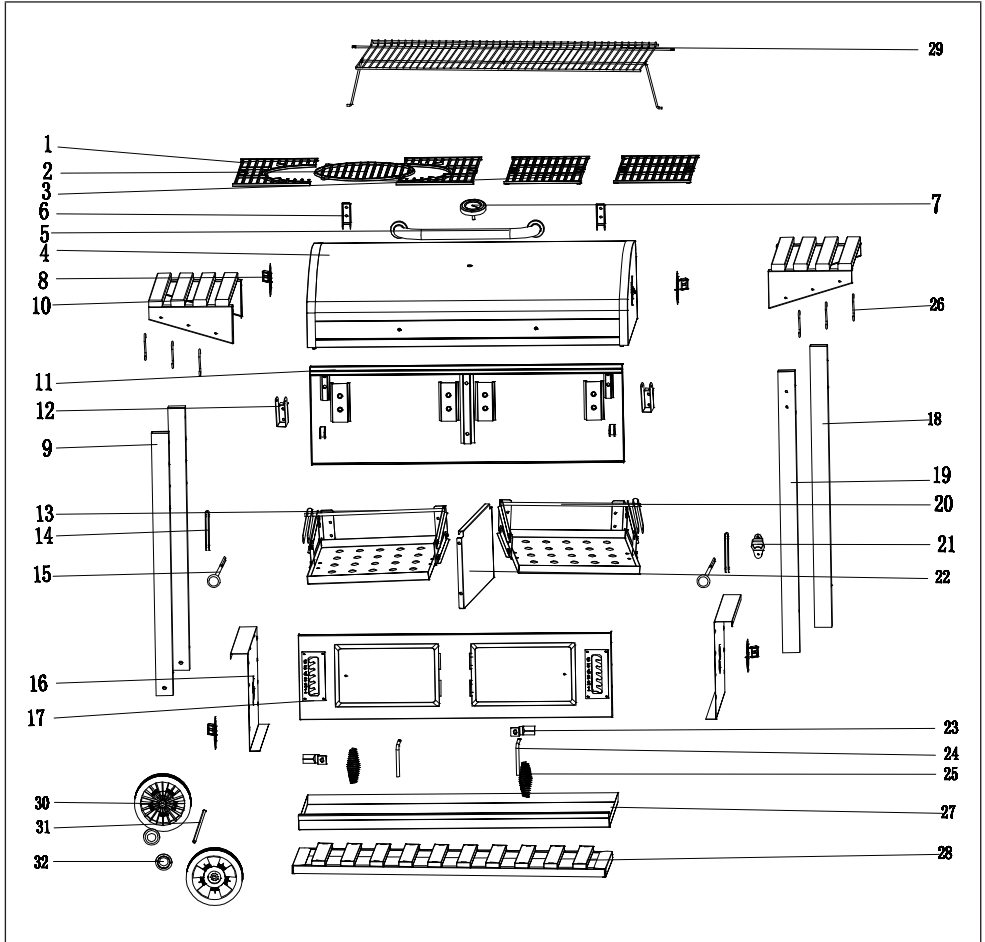





























## SCOPE OF DELIVERY



## PARTS LIST

1.		X 2	21.		X 1
2.		X 1	22.		X 1
3.		X 2	23.		X 2
4.		X 1	24.		X 2
5.		X 1	25.		X 2
6.		X 2	26.		X 6
7.		X 1	27.		X 1
8.		X 4	28.		X 1
9.		X 2	29.		X 1
10.		X 2	30.		X 2
11.		X 1	31.		X 1
12.		X 2	32.		X 2
13.		X 1			
14.		X 2			
15.		X 2			
16.		X 2			
17.		X 1			
18.		X 1			
19.		X 1			
20.		X 1			

A.  (M6x12mm) X 44

---

B.  (M6x60mm) X 4

---

C.  (M6x40mm) X 8

---

D.  X 10

---

E.  X 2

---

F.  X 2

---

G.  X 6

---

H.  (M6x25mm) X 2

---

I.  X 16

---

J.  X 2

---

---

---

---

---

---

---

---

---

---

---

---

---

---

---

---

---

---

---

---

---

---

## OPERATION

---

### Instructions for Use

- Do not use the grill to cook food until the charcoal is covered with a layer of ash.
- Do not move the grill while it is in use.
- Never use the grill indoors.
- Do not use gasoline or denatured alcohol to ignite or fan the flames.
- Keep children and pets away from the grill at all times.
- Place the grill in a stable position on a level surface.

### Preparation

- Before cooking food on your grill, you should carefully follow the steps below to both seal the finish and protect the internal steel. Failure to follow these steps can damage the surface and give your food a metallic taste.
- Coat all interior surfaces, including cooking grates, with cooking vegetable oil.
- Light a small fire on the charcoal pan, making sure the coals are not touching the walls.
- The grill must be lit and the embers maintained at least 30 minutes before the first grilling.

### Suitable Fuel

- Regular briquettes, Instant Light briquettes or charcoal can be used as a fuel source for grilling. Do not use mineral oil-based lighters or similar to light briquettes or charcoal, as these can spoil the food being grilled.
- Do not use a chimney starter for Instant Light briquettes.



#### CAUTION

Risk of injury! Do not use spirit or petrol to light or relight!

### Lighting the Grill

- Stack the charcoal briquettes or charcoal on the charcoal grate to form a pyramid.

**Solid fire starters:** Place the fire starter in the base of the pyramid. Light the fire starter in several places to ensure an even burn.

**Liquid or gel fire starters:** Coat the briquettes or charcoal with the liquid or gel and light according to the manufacturer's instructions.

- Never add charcoal lighter fluid or similar to hot or warm coals as this can be extremely dangerous.
- Once the fire has died out and turned grey, spread the charcoal out with a long-handled grilling tool.
- Now the grilling can begin!

**Note:** Always use caution when handling hot coals to avoid injury.

---

## CLEANING AND CARE

---

### Maintenance

- Clean the grill bowl with soap and water.
- To extend the life of your grill, use a proper cover.
- Store the grill in a dry place.

### Cleaning

- The frequency of cleaning depends on how often the grill is used.
- Make sure the coals are completely extinguished before cleaning the inside of the device.
- Rinse the device thoroughly with water and allow it to air dry before using it again. Wipe out the inside of the device with a cloth or paper towels.
- When you have finished grilling and the device has cooled down sufficiently, remove all ash residue. Moisture collects in the ash, which can lead to premature rusting and decay.
- Rust can form on the inside of your grill. A light coat of vegetable oil on the interior surfaces will help protect your grill. The exterior of the grill may occasionally need touching up. The use of commercially available black high-temperature paint is recommended.

**Note:** Never paint the inside of the grill!



**Cher client, chère cliente,**

Toutes nos félicitations pour l'acquisition de ce nouvel appareil. Lisez attentivement les consignes suivantes et suivez-les pour éviter d'éventuels dommages. Nous ne saurions être tenus pour responsables des dommages dus au non-respect des consignes et à la mauvaise utilisation de l'appareil. Scannez le QR-Code pour obtenir la dernière version du mode d'emploi ainsi que d'autres informations concernant le produit.

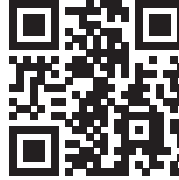

---

## SOMMAIRE

---

Consignes de sécurité 24  
Descriptif de l'appareil 26  
Contenu de l'emballage 27  
Liste des pièces 28  
Utilisation 30  
Nettoyage et entretien 31  
Notice de montage 53

---

## FABRICANT ET IMPORTATEUR (UK)

---

**Fabricant :**

Chal-Tec GmbH, Wallstraße 16, 10179 Berlin, Allemagne.

**Importateur pour la Grande Bretagne :**

Berlin Brands Group UK Limited  
PO Box 42  
272 Kensington High Street  
London, W8 6ND  
United Kingdom

## CONSIGNES DE SÉCURITÉ



### DANGER

Risque d'étouffement ! N'utilisez jamais l'appareil dans un espace clos tel qu'une maison, un véhicule ou une tente. Cela peut entraîner la mort en raison du monoxyde de carbone inodore produit lors de la combustion du charbon.

- Conservez le mode d'emploi en lieu sûr.
- Lisez attentivement les instructions d'allumage du barbecue à charbon avant d'utiliser l'appareil.

Le non-respect de ces instructions et précautions de sécurité peut entraîner des blessures graves. Lisez les indications suivantes avant d'utiliser le barbecue.

- Ce barbecue ne doit être utilisé qu'à l'extérieur et en aucun cas à l'intérieur.
- Avant d'utiliser le barbecue, installez-le sur une surface plane aussi à l'abri du vent que possible et aussi loin que possible des surplombs et des arbres.
- Maintenez une distance de sécurité de 1,5 mètre par rapport aux matériaux combustibles.
- N'utilisez pas de liquides tels que de l'essence ou des liquides inflammables similaires pour allumer ou ventiler le barbecue ou pour alimenter le charbon de bois chaud ou brûlant !
- Ne laissez pas le barbecue chaud ou les charbons ardents et les cendres sans surveillance.
- La quantité maximale de briquettes pour ces barbecues est de 1 kg pour chaque côté du plateau du barbecue.
- Suivez attentivement les instructions sur le sac de combustible.
- Ne placez pas le couvercle sur le barbecue tant que la flamme n'est pas éteinte.
- N'utilisez pas le barbecue pour cuire des aliments tant que le charbon de bois n'est pas recouvert d'une couche de cendre.
- Le charbon de bois devient très chaud. Prenez les précautions appropriées.
- Portez des gants de cuisine résistants à la chaleur lorsque vous faites des grillades ou réglez les ouvertures de ventilation.
- Lors de l'extinction du charbon de bois, placez le couvercle sur le plat et fermez les ouvertures de ventilation si nécessaire.
- Ne retirez pas les cendres tant que le charbon de bois n'est pas complètement brûlé et éteint.
- Retirez les cendres avant le prochain barbecue. Assurez-vous que les cendres sont froides lorsque vous les enlevez.
- Tenez toujours les enfants et les animaux domestiques à distance du barbecue.



### ATTENTION

Risque de blessure ! Ce barbecue devient très chaud, ne le déplacez pas pendant son utilisation. Laissez l'appareil refroidir complètement avant de le déplacer ou de le ranger.



⚠		
		
		

**ATTENTION !**  
N'UTILISEZ PAS D'ALCOOL OU D'ESSENCE  
POUR ALLUMER OU RALLUMER LE FEU !

---

**DESCRIPTIF DE L'APPAREIL**



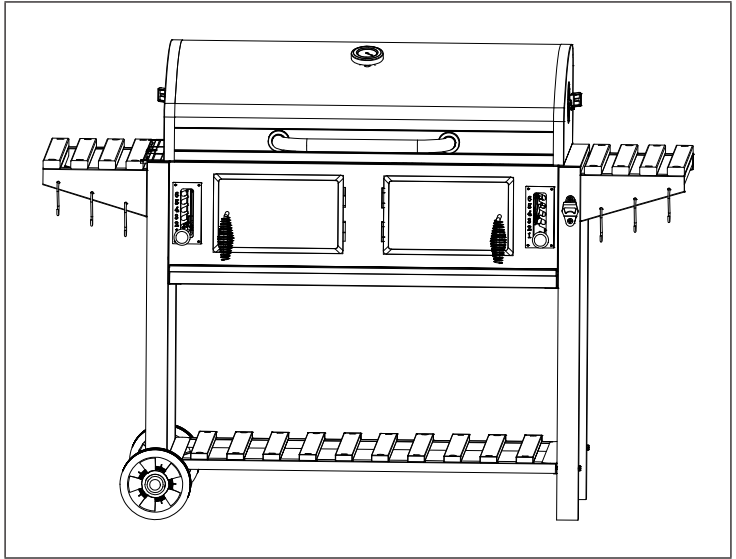



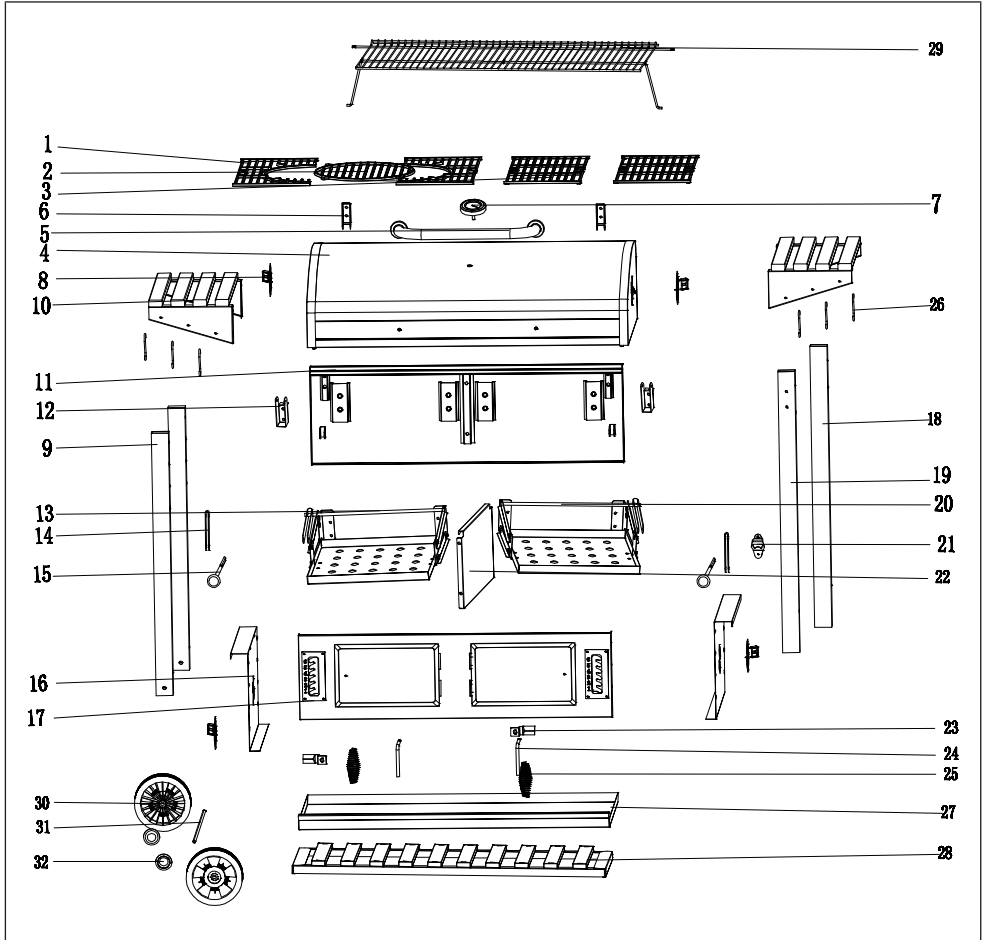

























---



# CONTENU DE L'EMBALLAGE



## LISTE DES PIÈCES

1.		X 2	21.		X 1
2.		X 1	22.		X 1
3.		X 2	23.		X 2
4.		X 1	24.		X 2
5.		X 1	25.		X 2
6.		X 2	26.		X 6
7.		X 1	27.		X 1
8.		X 4	28.		X 1
9.		X 2	29.		X 1
10.		X 2	30.		X 2
11.		X 1	31.		X 1
12.		X 2	32.		X 2
13.		X 1			
14.		X 2			
15.		X 2			
16.		X 2			
17.		X 1			
18.		X 1			
19.		X 1			
20.		X 1			

A.  (M6x12mm) X 44

---

B.  (M6x60mm) X 4

---

C.  (M6x40mm) X 8

---

D.  X 10

---

E.  X 2

---

F.  X 2

---

G.  X 6

---

H.  (M6x25mm) X 2

---

I.  X 16

---

J.  X 2

---

---

---

---

---

---

---

---

---

---

---

---

---

---

---

---

---

---

---

---

---

---

## UTILISATION

---

### Remarques sur l'utilisation

- N'utilisez pas le barbecue pour cuire des aliments tant que le charbon de bois n'est pas recouvert d'une couche de cendre.
- Ne déplacez pas le barbecue pendant son utilisation.
- N'utilisez jamais le barbecue à l'intérieur.
- N'utilisez pas d'essence ou d'alcool dénaturé pour allumer ou attiser les flammes.
- Tenez toujours les enfants et les animaux domestiques à distance du barbecue.
- Placez le barbecue dans une position stable sur une surface plane.

### Préparatifs

- Avant de cuire des aliments sur votre barbecue, suivez attentivement les étapes ci-dessous à la fois pour sceller la peinture et protéger l'acier intérieur. Le non-respect de ces étapes peut endommager la surface et donner à vos aliments un goût métallique.
- Enduisez toutes les surfaces intérieures, y compris les grilles de cuisson, d'huile végétale de cuisson.
- Allumez un petit feu sur la poêle à charbon, en vous assurant que les charbons ne sont pas contre les parois.
- Le barbecue doit être allumé et les braises entretenues au moins 30 minutes avant la première cuisson.

### Combustible approprié

- Les briquettes ordinaires, les briquettes Instant Light ou le charbon de bois peuvent servir de source de combustible pour les grillades. N'utilisez pas de briquettes à base d'huile minérale ou similaires aux briquettes légères ou au charbon de bois, car celles-ci peuvent détériorer les aliments à griller.
- N'utilisez pas de démarreur de cheminée avec des briquettes Instant Light.



#### ATTENTION

Risque de blessure ! N'utilisez pas d'alcool ou d'essence pour allumer ou rallumer le feu !

### Allumage du barbecue

- Empilez les briquettes de charbon ou le charbon de bois sur la grille à charbon pour former une pyramide.

**Allume-barbecue solide** : placez l'allume-barbecue à la base de la pyramide. Allumez l'allume-barbecue à plusieurs endroits pour assurer une combustion uniforme.

**Allume-barbecue liquide ou en gel :** Enduisez les briquettes ou le charbon de bois avec le liquide ou le gel et allumez selon les instructions du fabricant.

- N'ajoutez jamais d'allume-feu ou similaire aux charbons ardents ou tièdes car cela peut être extrêmement dangereux.
- Une fois que le feu s'est éteint et que le charbon de bois est devenu gris, étalez le charbon de bois avec un outil de barbecue à long manche.
- Vous pouvez commencer les grillades !

**Remarque :** Soyez toujours prudent lorsque vous manipulez des charbons ardents pour éviter les blessures.

---

## NETTOYAGE ET ENTRETIEN

---

### Maintenance

- Nettoyez la lèchefrite avec de l'eau et du savon.
- Utilisez une housse appropriée pour prolonger la durée de vie de votre barbecue.
- Stockez le barbecue dans un endroit sec.

### Nettoyage

- La fréquence de nettoyage dépend de la fréquence d'utilisation du barbecue.
- Assurez-vous que les charbons sont complètement éteints avant de nettoyer l'intérieur de l'appareil.
- Rincez soigneusement l'appareil à l'eau et laissez-le sécher à l'air avant de le réutiliser. Essuyez l'intérieur de l'appareil avec un chiffon ou des serviettes en papier.
- Lorsque vous avez fini de cuire vos grillades et que l'appareil a suffisamment refroidi, retirez tous les résidus de cendre. L'humidité s'accumule dans les cendres, ce qui peut entraîner une rouille et une décomposition prématurées.
- De la rouille peut se former à l'intérieur de votre barbecue. Une légère couche d'huile végétale sur les surfaces intérieures aidera à protéger votre barbecue. L'extérieur du barbecue peut parfois nécessiter des retouches. L'utilisation de peinture noire haute température disponible dans le commerce est recommandée.

**Remarque :** Ne peignez jamais l'intérieur du barbecue !





**Estimado cliente:**

Le felicitamos por la adquisición de este producto. Lea atentamente el siguiente manual y siga cuidadosamente las instrucciones de uso con el fin de evitar posibles daños. La empresa no se responsabiliza de los daños ocasionados por un uso indebido del producto o por haber desatendido las indicaciones de seguridad. Escanee el siguiente código QR para obtener acceso al manual de usuario más reciente e información adicional sobre el producto.



---

**ÍNDICE**

---

Indicaciones de seguridad	34
Descripción general del aparato	36
Contenido del envío	37
Lista de piezas	38
Funcionamiento	40
Limpieza y cuidado	41
Instrucciones de montaje	53

---

**FABRICANTE E IMPORTADOR (REINO UNIDO)**

---

**Fabricante:**

Chal-Tec GmbH, Wallstraße 16, 10179 Berlín, Alemania.

**Importador para Gran Bretaña:**

Berlin Brands Group UK Limited  
PO Box 42  
272 Kensington High Street  
London, W8 6ND  
Reino Unido

## INDICACIONES DE SEGURIDAD



### PELIGRO

¡Peligro de asfixia! Nunca utilice la unidad en espacios cerrados como casas, vehículos o tiendas de campaña. De lo contrario, podría morir debido al monóxido de carbono inodoro que se produce al arder el carbón.

- Conserve este manual de instrucciones en un lugar seguro.
- Lea atentamente las instrucciones para encender la barbacoa de carbón antes de utilizar el aparato.

El incumplimiento de estas instrucciones y precauciones de seguridad puede provocar lesiones graves. Lea las siguientes indicaciones antes de utilizar el grill.

- Esta barbacoa sólo debe utilizarse al aire libre y nunca en interiores.
- Antes de utilizar la barbacoa, colóquela en una superficie llana y lo más protegida posible del viento, lo más alejada posible de salientes y árboles.
- Mantenga una distancia de seguridad de 1,5 metros de los materiales combustibles.
- No utilice líquidos como gasolina o similares altamente inflamables para encender la barbacoa o el carbón caliente.
- No deje la barbacoa caliente o las brasas y cenizas calientes sin vigilancia.
- La cantidad máxima de briquetas para estas parrillas es de 1 kg por cada lado de la bandeja de la parrilla.
- Siga atentamente las instrucciones de la bolsa de combustible.
- No ponga la tapa en la parrilla hasta que la llama se haya apagado.
- No utilice la parrilla para preparar alimentos hasta que el carbón esté cubierto con una capa de ceniza.
- El carbón se calienta mucho. Tome las precauciones adecuadas.
- Utilice guantes de horno resistentes al calor para asar o ajustar las rejillas de ventilación.
- Al apagar el carbón, coloque la tapa sobre la bandeja y cierre todas las rejillas de ventilación si es necesario.
- No retire las cenizas hasta que el carbón se haya quemado por completo y se haya apagado.
- Retire la ceniza antes de la próxima barbacoa. Asegúrate de que la ceniza esté fría cuando la retires.
- Mantenga a los niños y a los animales domésticos alejados de la barbacoa en todo momento.



### ATENCIÓN

¡Peligro de lesiones! La parrilla se calienta mucho, no la mueva durante el funcionamiento. Deje que el aparato se enfríe completamente antes de moverlo o guardarlo.

⚠		
		
		

**¡ATENCIÓN!**  
¡NO UTILICE ALCOHOL O GASOLINA PARA  
ENCENDER O VOLVER A ENCENDER EL  
HORNO DE PIZZA!



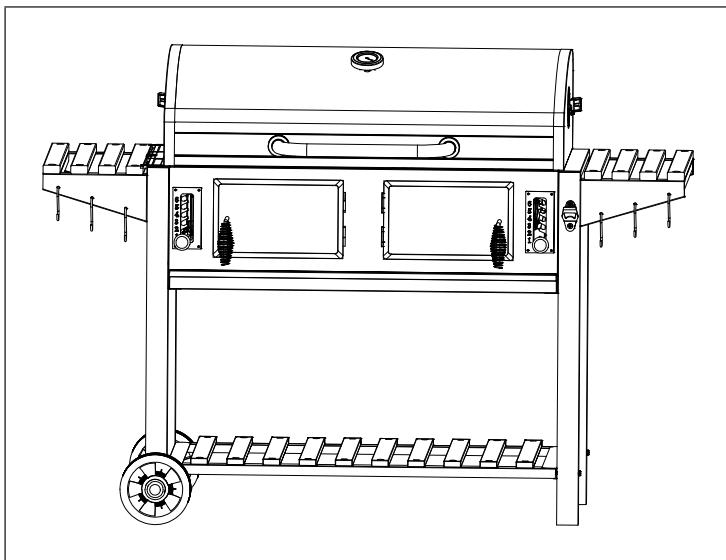



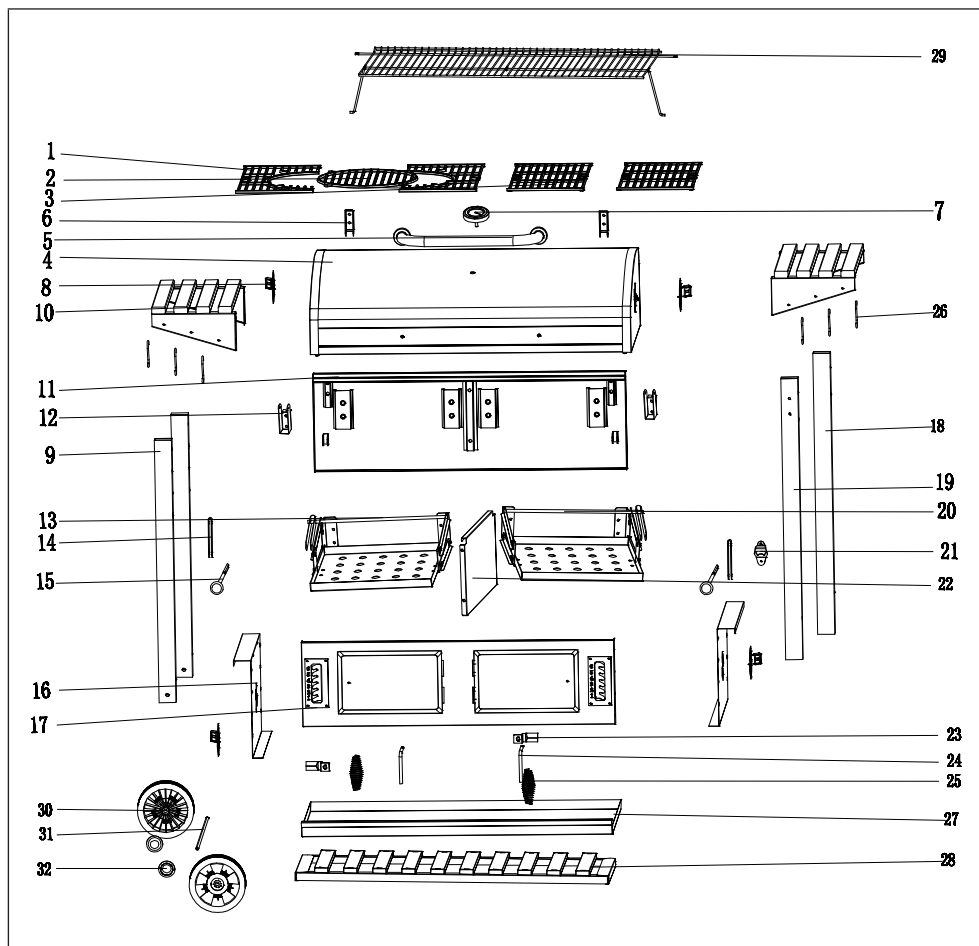

























## DESCRIPCIÓN GENERAL DEL APARATO



# CONTENIDO DEL ENVÍO



## LISTA DE PIEZAS

1.		X 2	21.		X 1
2.		X 1	22.		X 1
3.		X 2	23.		X 2
4.		X 1	24.		X 2
5.		X 1	25.		X 2
6.		X 2	26.		X 6
7.		X 1	27.		X 1
8.		X 4	28.		X 1
9.		X 2	29.		X 1
10.		X 2	30.		X 2
11.		X 1	31.		X 1
12.		X 2	32.		X 2
13.		X 1			
14.		X 2			
15.		X 2			
16.		X 2			
17.		X 1			
18.		X 1			
19.		X 1			
20.		X 1			

A.  (M6x12mm) X 44

---

B.  (M6x60mm) X 4

---

C.  (M6x40mm) X 8

---

D.  X 10

---

E.  X 2

---

F.  X 2

---

G.  X 6

---

H.  (M6x25mm) X 2

---

I.  X 16

---

J.  X 2

---

---

---

---

---

---

---

---

---

---

---

---

---

---

---

---

---

---

---

---

---

---

## FUNCIONAMIENTO

---

### Indicaciones de uso

- No utilice la parrilla para preparar alimentos hasta que el carbón esté cubierto con una capa de ceniza.
- No mueva la parrilla mientras esté en uso.
- No utilice nunca la barbacoa en interiores.
- No utilice gasolina ni alcohol metílico para encender o prender fuego.
- Mantenga a los niños y a los animales domésticos alejados de la barbacoa en todo momento.
- Coloque la barbacoa en una posición estable sobre una superficie plana.

### Preparación

- Antes de preparar alimentos con su parrilla, siga cuidadosamente los pasos que se indican a continuación tanto para sellar el acabado como para proteger el acero interior. Si no sigue estos pasos, el acabado puede dañarse y su comida puede adquirir un sabor metálico.
- Cubra todas las superficies internas, incluidas las rejillas de la parrilla, con aceite vegetal de cocina.
- Enciende un pequeño fuego en la carbonera, procurando que las brasas no toquen las paredes.
- La barbacoa debe encenderse y mantener las brasas al menos 30 minutos antes de la primera barbacoa.

### Combustible adecuado

- Se pueden utilizar briquetas normales, briquetas ligeras instantáneas o carbón vegetal como fuente de combustible para hacer barbacoas. No utilice encendedores a base de aceite mineral o similares para encender las briquetas o el carbón, ya que pueden estropear los alimentos de la barbacoa.
- No utilice una chimenea de encendido para briquetas de luz instantánea.



#### PRECAUCIÓN

¡Peligro de lesiones! No utilice alcohol ni gasolina para encender o volver a encender.

### Encender la barbacoa

- Apila las briquetas o el carbón en la rejilla para carbón formando una pirámide.

**Encendedor de barbacoa sólido:** Coloque el encendedor de barbacoa en la base de la pirámide. Encienda el encendedor de la barbacoa en varios lugares para garantizar una combustión uniforme.



**Encendedor de barbacoa líquido o en gel:** Cubra las **briquetas** o el carbón con el líquido o el gel y enciéndalo siguiendo las instrucciones del fabricante.

- Nunca añada encendedor de barbacoa o similar al carbón caliente o tibio, ya que puede ser extremadamente peligroso.
- Una vez que el fuego se haya apagado y el carbón se haya vuelto gris, espárzalo con un utensilio de barbacoa de mango largo.
- ¡Ya puede empezar la barbacoa!

**Nota:** Tenga siempre cuidado al manipular brasas calientes para evitar lesiones.

---

## LIMPIEZA Y CUIDADO

---

### Mantenimiento

- Limpie la bandeja de la parrilla con agua y jabón.
- Utilice una funda adecuada para prolongar la vida útil de su parrilla.
- Guarde el Grill en un lugar seco.

### Limpieza

- La frecuencia de limpieza depende de la frecuencia de uso de la parrilla.
- Asegúrese de que las brasas estén completamente apagadas antes de limpiar el interior del aparato.
- Aclara la unidad muy bien con agua limpia y deja que seque al aire antes de volver a utilizarla. Limpie el interior del aparato con un paño o papel de cocina.
- Cuando haya terminado de asar y el aparato se haya enfriado lo suficiente, retire todos los restos de ceniza. La humedad se acumula en las cenizas, lo que puede provocar su oxidación y descomposición prematuras.
- Puede formarse óxido en el interior de la parrilla. Una ligera capa de aceite vegetal en las superficies interiores ayudará a proteger la barbacoa. Las superficies exteriores de la barbacoa pueden necesitar retoques ocasionales. Se recomienda el uso de pintura negra de alta temperatura disponible en el mercado.

**Nota:** ¡No pinte nunca el interior de la parrilla!



**Gentile cliente,**

La ringraziamo per l'acquisto del dispositivo. La preghiamo di leggere attentamente le seguenti indicazioni e di seguirle per evitare eventuali danni. Non ci assumiamo alcuna responsabilità per danni scaturiti da una mancata osservanza delle avvertenze di sicurezza e da un uso improprio del dispositivo. Scansionare il seguente codice QR per accedere al manuale d'uso più recente e ricevere informazioni sul prodotto.



---

## **INDICE**

---

Avvertenze di sicurezza 44  
Descrizione del dispositivo 46  
Volume di consegna 47  
Lista delle parti 48  
Utilizzo 50  
Pulizia e manutenzione 51  
Manuale di montaggio 53

---

## **PRODUTTORE E IMPORTATORE (UK)**

---

**Produttore:**

Chal-Tec GmbH, Wallstraße 16, 10179 Berlino, Germania.

**Importatore per la Gran Bretagna:**

Berlin Brands Group UK Limited  
PO Box 42  
272 Kensington High Street  
London, W8 6ND  
United Kingdom

## AVVERTENZE DI SICUREZZA



### PERICOLO

Pericolo di soffocamento! Non utilizzare assolutamente il dispositivo in locali chiusi, come case, mezzi di trasporto o tende. In caso contrario, il monossido di carbonio inodore generato durante la combustione della carbonella potrebbe causare la morte.

- Conservare il manuale d'uso in un luogo sicuro.
- Leggere attentamente le indicazioni relative all'accensione della griglia a carbonella prima di procedere all'utilizzo del dispositivo.

La mancata osservanza delle avvertenze e delle misure di sicurezza può causare gravi lesioni. Leggere le seguenti indicazioni prima di utilizzare la griglia.

- Questa griglia può essere utilizzata solo all'aperto. Non utilizzarla assolutamente in locali chiusi.
- Prima di procedere all'utilizzo, posizionare la griglia su una superficie piana, al riparo dal vento e lontano da alberi o strutture sovrastanti.
- Tenere una distanza di sicurezza di 1,5 metri da materiali infiammabili.
- Non utilizzare benzina o altri liquidi facilmente infiammabili per accendere o ravvivare il fuoco!
- Non lasciare prive di supervisione la griglia accesa o le braci e la cenere bollenti.
- La quantità massima di carbonella per ogni lato del braciere di questa griglia è 1 kg.
- Rispettare le indicazioni sulla confezione del combustibile.
- Non posizionare il coperchio sulla griglia prima dello spegnimento delle fiamme.
- Utilizzare la griglia per la preparazione delle pietanze solo quando la carbonella presenta uno strato di cenere.
- La carbonella diventa estremamente calda. Adottare misure di sicurezza adeguate.
- Quando si griglia o si regolano le aperture di ventilazione, indossare sempre guanti resistenti al calore.
- Per spegnere la carbonella, mettere il coperchio sulla griglia e, se necessario, chiudere tutte le aperture di ventilazione.
- Rimuovere la cenere solo quando la carbonella è completamente consumata e spenta.
- Rimuovere la cenere prima di riutilizzare la griglia. Quando si rimuove la cenere, assicurarsi che sia fredda.
- Tenere sempre bambini e animali domestici lontano dalla griglia.



### ATTENZIONE

Pericolo di lesioni! La griglia diventa molto calda, non muoverla durante l'uso. Lasciar raffreddare completamente il dispositivo prima di spostarlo o metterlo via.

⚠		
		
		

**ATTENZIONE!**  
NON UTILIZZARE ALCOOL O BENZINA PER  
ACCENDERE O RIACCENDERE IL FUOCO!

---

**DESCRIZIONE DEL DISPOSITIVO**



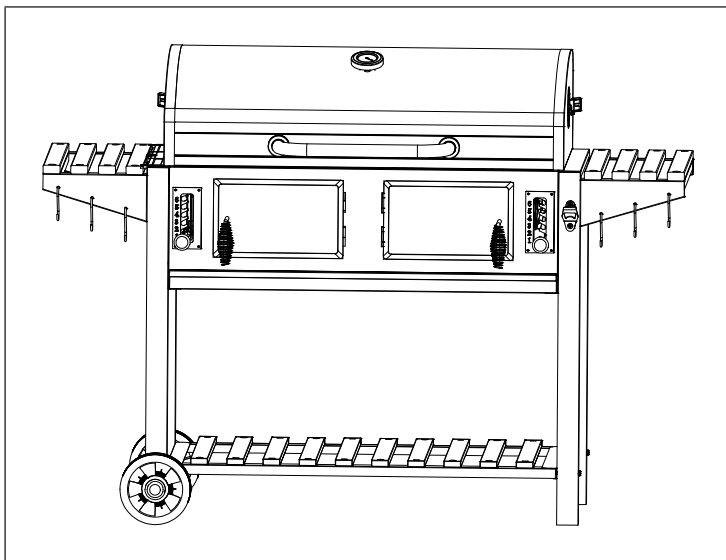



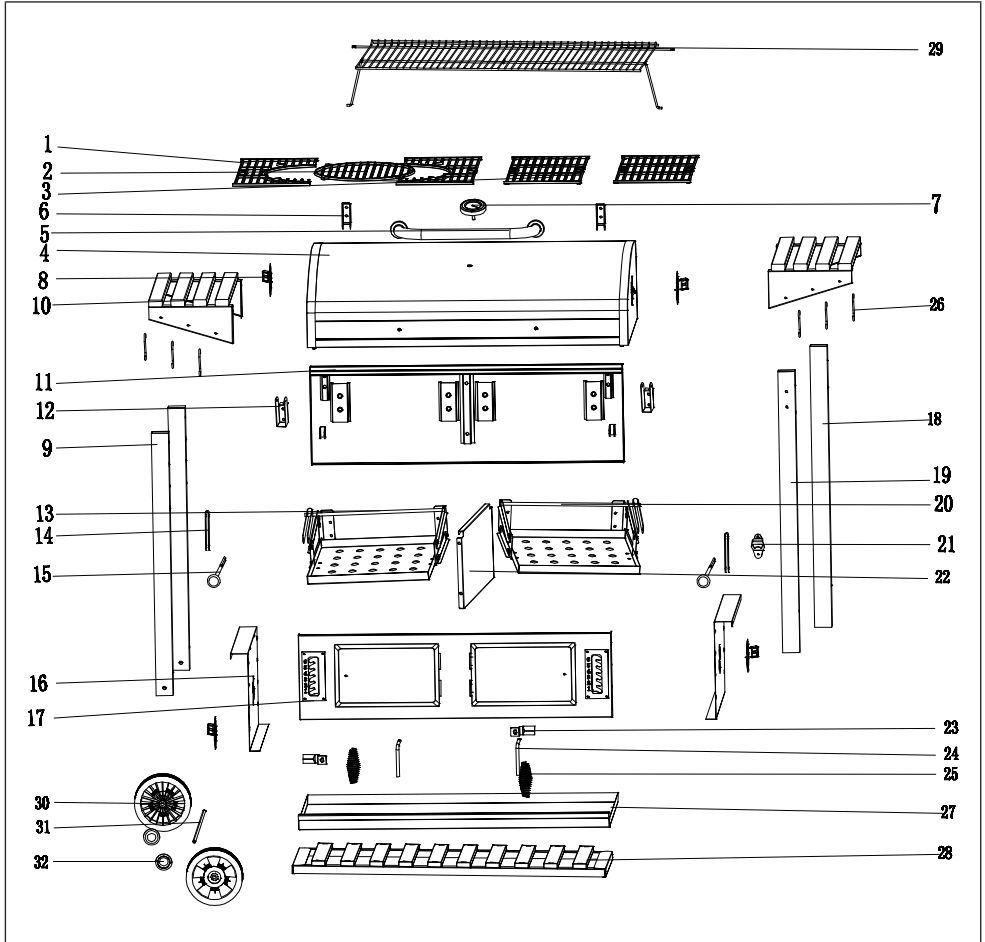

























---



# VOLUME DI CONSEGNA



## LISTA DELLE PARTI

1.		X 2	21.		X 1
2.		X 1	22.		X 1
3.		X 2	23.		X 2
4.		X 1	24.		X 2
5.		X 1	25.		X 2
6.		X 2	26.		X 6
7.		X 1	27.		X 1
8.		X 4	28.		X 1
9.		X 2	29.		X 1
10.		X 2	30.		X 2
11.		X 1	31.		X 1
12.		X 2	32.		X 2
13.		X 1			
14.		X 2			
15.		X 2			
16.		X 2			
17.		X 1			
18.		X 1			
19.		X 1			
20.		X 1			



A.  (M6x12mm) X 44

\_\_\_\_\_

B.  (M6x60mm) X 4

\_\_\_\_\_

C.  (M6x40mm) X 8

\_\_\_\_\_

D.  X 10

\_\_\_\_\_

E.  X 2

\_\_\_\_\_

F.  X 2

\_\_\_\_\_

G.  X 6

\_\_\_\_\_

H.  (M6x25mm) X 2

\_\_\_\_\_

I.  X 16

\_\_\_\_\_

J.  X 2

\_\_\_\_\_

\_\_\_\_\_

\_\_\_\_\_

\_\_\_\_\_

\_\_\_\_\_

\_\_\_\_\_

\_\_\_\_\_

\_\_\_\_\_

\_\_\_\_\_

\_\_\_\_\_

\_\_\_\_\_

\_\_\_\_\_

\_\_\_\_\_

\_\_\_\_\_

\_\_\_\_\_

\_\_\_\_\_

\_\_\_\_\_

\_\_\_\_\_

\_\_\_\_\_

\_\_\_\_\_

\_\_\_\_\_

---

## UTILIZZO

---

### Note sull'utilizzo

- Utilizzare la griglia per la preparazione delle pietanze solo quando la carbonella presenta uno strato di cenere.
- Non spostare la griglia mentre è in funzione.
- Non utilizzare assolutamente la griglia in locali chiusi.
- Non utilizzare benzina o alcol etilico per accendere o ravvivare il fuoco.
- Tenere sempre bambini e animali domestici lontano dalla griglia.
- Posizionare stabilmente la griglia su una superficie piana.

### Preparazione

- Prima di preparare alimenti con la griglia, realizzare i seguenti passaggi per sigillare la verniciatura e proteggere l'acciaio all'interno. Se non si rispettano tali passaggi, la superficie potrebbe danneggiarsi e le pietanze potrebbero prendere un gusto metallico.
- Strofinare tutte le superfici interne, inclusa la griglia di cottura, con olio vegetale.
- Accendere un fuocherello sul contenitore per la carbonella, assicurandosi che la carbonella non sia a contatto con le pareti.
- Prima di procedere con il primo utilizzo, la griglia deve essere accesa e la brace deve ardere per almeno 30 minuti.

### Combustibile adatto

- Come combustibile per questa griglia è possibile utilizzare bricchetti normali, bricchetti Instant-Light e carbonella. Non utilizzare accendifuoco a base di oli minerali o prodotti simili per accendere i bricchetti o la carbonella, altrimenti potrebbero rovinare le pietanze.
- Se si utilizzano bricchetti Instant-Light, non utilizzare ciminiera di accensione.



#### ATTENZIONE

Pericolo di lesione! Non utilizzare alcol o benzina per accendere o riaccendere il fuoco!

### Accendere la griglia

- Impilare la carbonella o i bricchetti sull'apposita griglia formando una piramide.

**Accendifuoco solidi:** poggiare l'accendifuoco nella base della piramide. Accendere l'accendifuoco in diversi punti per garantire una combustione omogenea.

**Accendifuoco liquidi o in gel:** distribuire il liquido o il gel sui bricchetti o sulla carbonella e accenderlo seguendo le indicazioni del produttore.

- Non aggiungere mai accendifuoco o prodotti simili a carbonella bollente o calda, dato che può essere estremamente pericoloso.
- Non appena le fiamme si sono estinte e la carbonella è diventata grigia, distribuirla con un attizzatoio.
- Ora si può iniziare a grigliare!

**Nota:** prestare sempre la massima attenzione quando si maneggia la carbonella bollente, in modo da evitare lesioni.

---

## PULIZIA E MANUTENZIONE

---

### Manutenzione

- Pulire il braciere della griglia con acqua e sapone.
- Utilizzare una copertura adatta per estendere la vita utile della griglia.
- Conservare la griglia in un luogo asciutto.

### Pulizia

- Gli intervalli di pulizia dipendono dalla frequenza di utilizzo della griglia.
- Prima di pulire l'interno del dispositivo, assicurarsi che la carbonella sia completamente spenta.
- Sciacquare a fondo il dispositivo con acqua pulita e lasciarlo asciugare all'aria prima di utilizzarlo nuovamente. Pulire l'interno del dispositivo con un panno di tessuto o carta.
- Al termine della grigliata e dopo il raffreddamento del dispositivo, rimuovere i residui di cenere. Nella cenere può accumularsi umidità, che può causare ruggine e danni.
- All'interno della griglia potrebbe formarsi ruggine. Sfregando un po' d'olio vegetale sulle superfici interne è possibile proteggere la griglia. Di tanto in tanto, potrebbe essere necessario ritoccare le superfici esterne della griglia. Consigliamo di utilizzare vernice nera resistente alle alte temperature.

**Nota:** non verniciare mai l'interno della griglia!



---

**MONTAGEANLEITUNG**

---

---

**ASSEMBLY INSTRUCTIONS**

---

---

**NOTICE DE MONTAGE**

---

---

**INSTRUCCIONES DE MONTAJE**

---

---

**MANUALE DI MONTAGGIO**

---

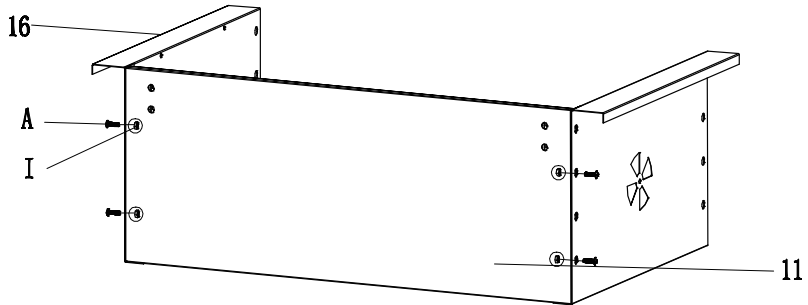

1

**A X 4**  
**I X 4**

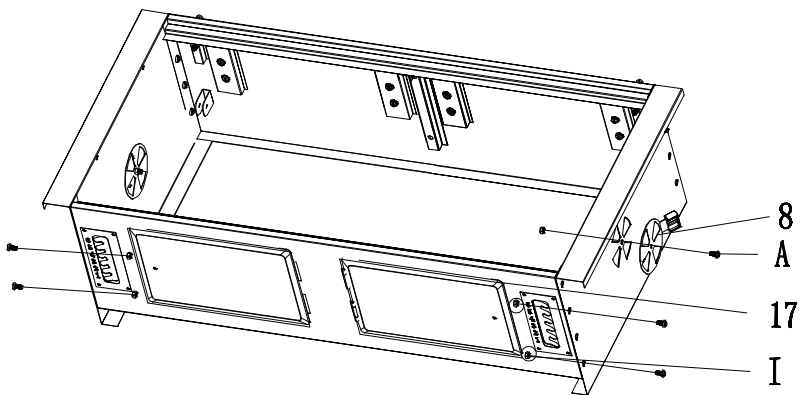

2

**A X 6**  
**I X 6**

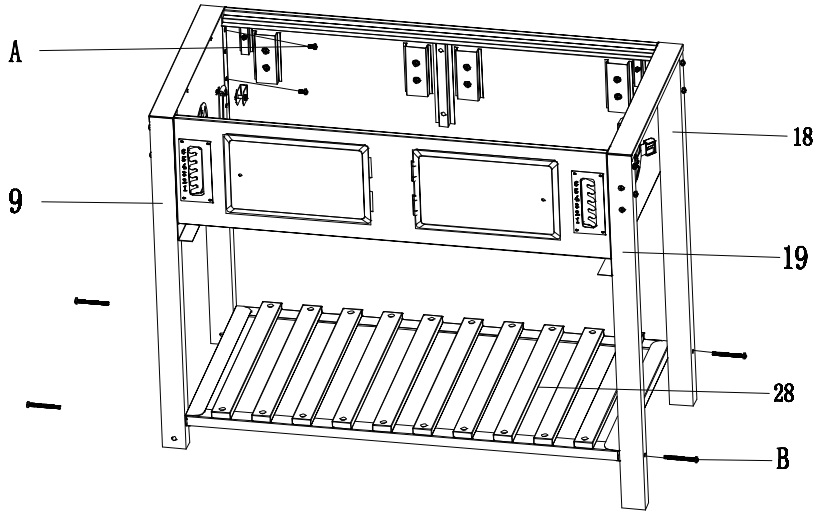

3

A X 8  
B X 4

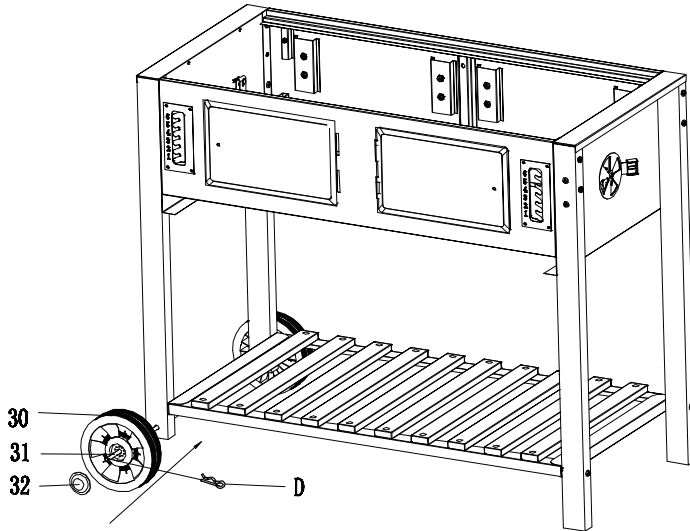

4

D X 2

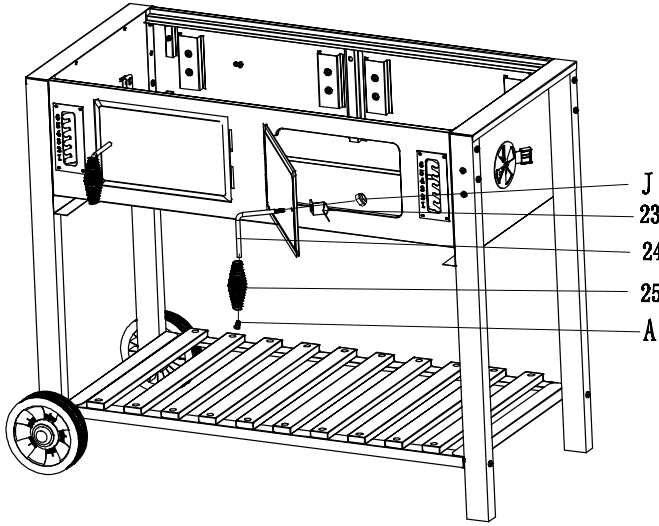

5

**A X 2**  
**J X 2**

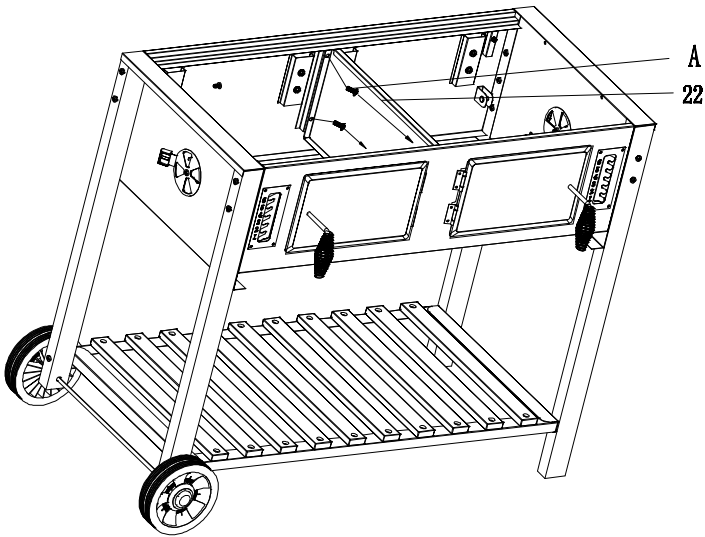

6

**A X 4**



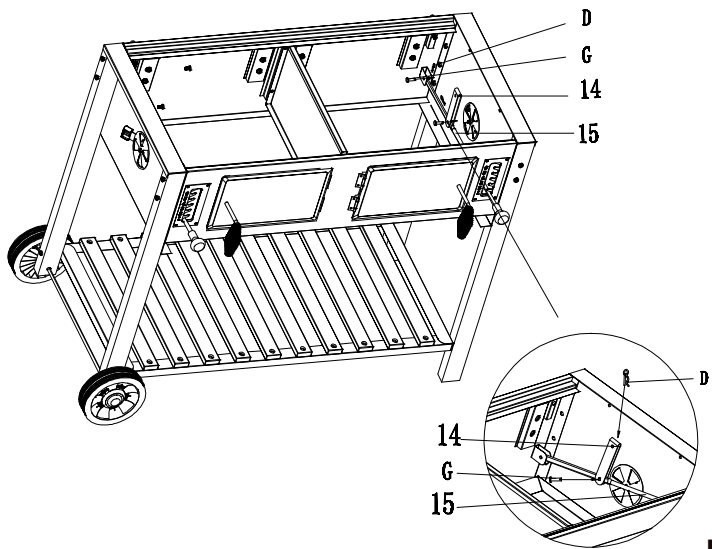

7

**DX4**  
**GX4**

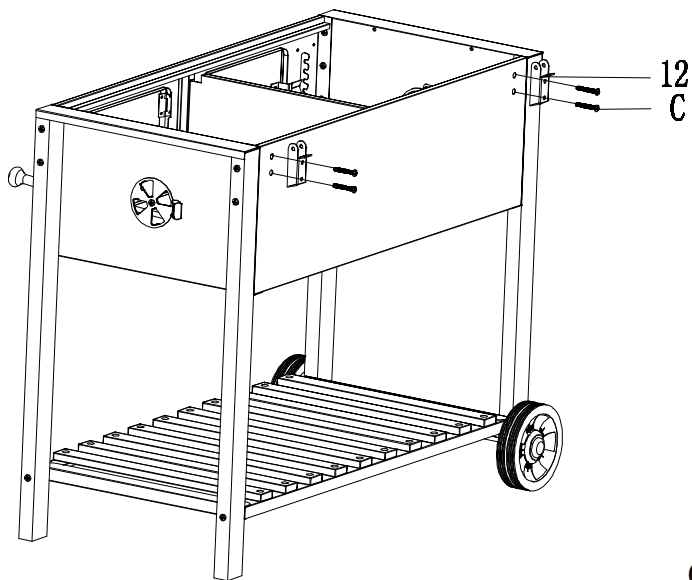

8

**CX4**

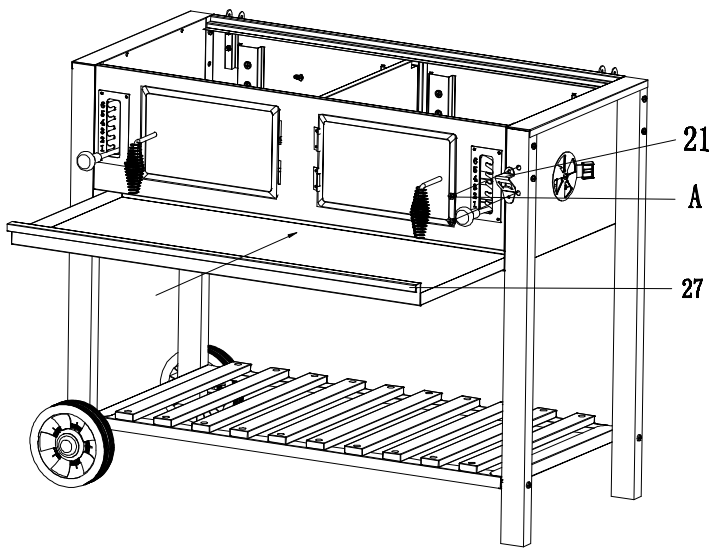

9

A X 2

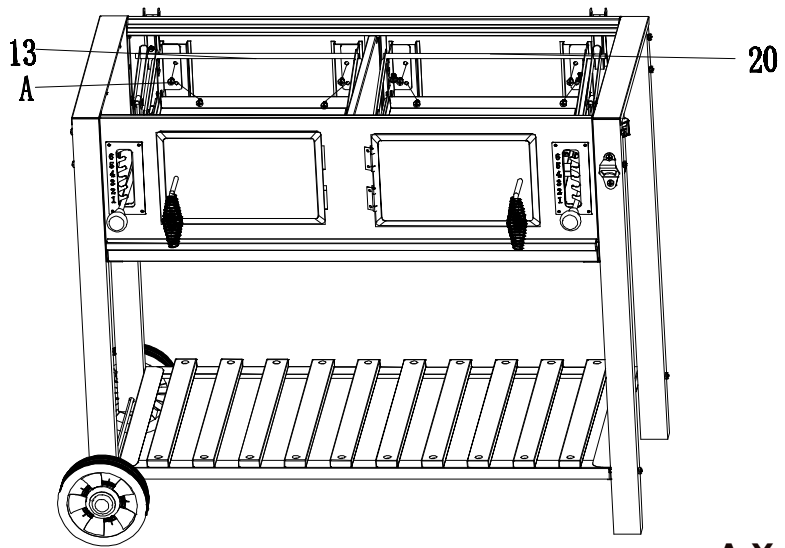

10

A X 8

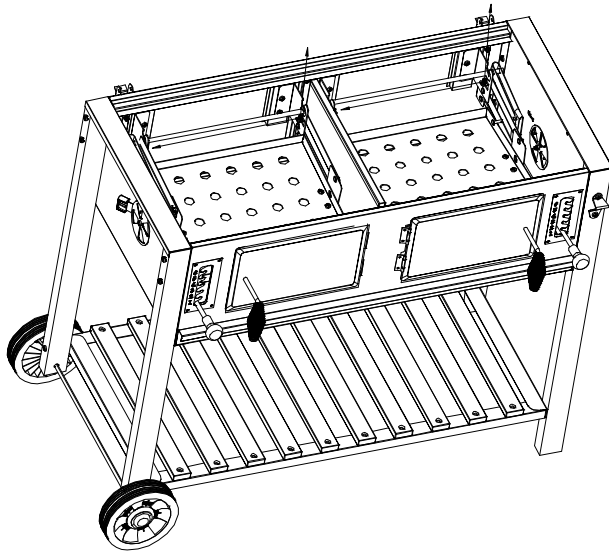
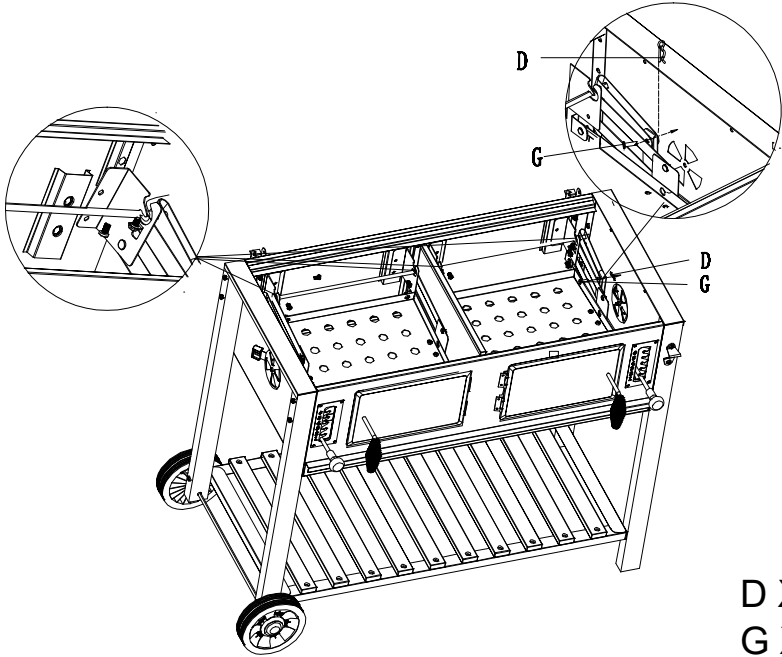

12

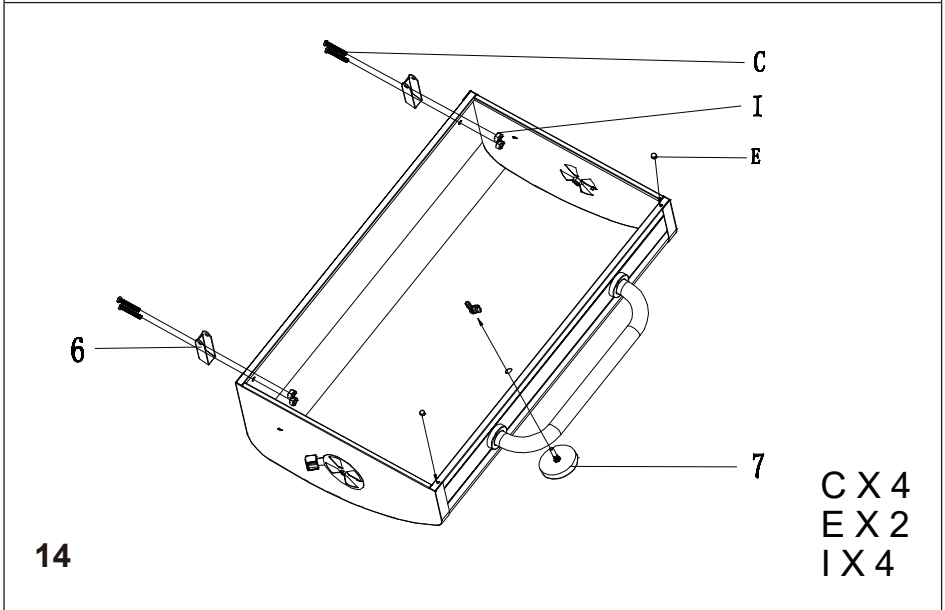
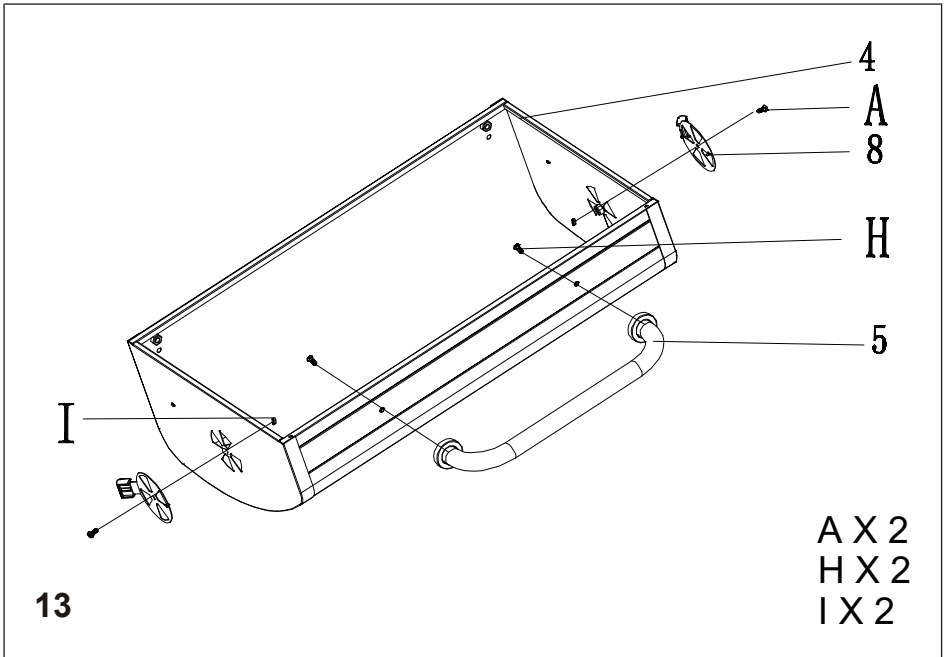

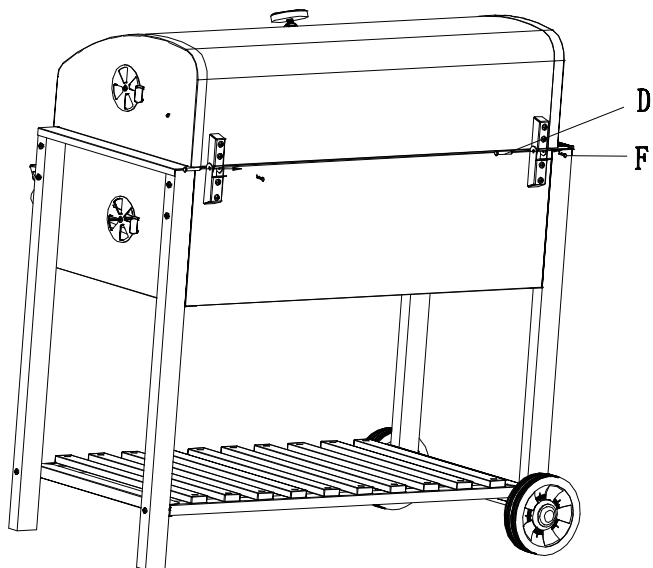

15

DX 2  
FX 2

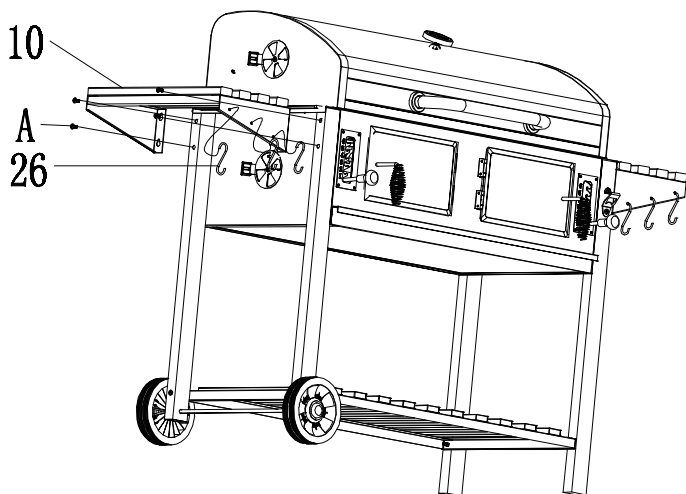

16

AX 8

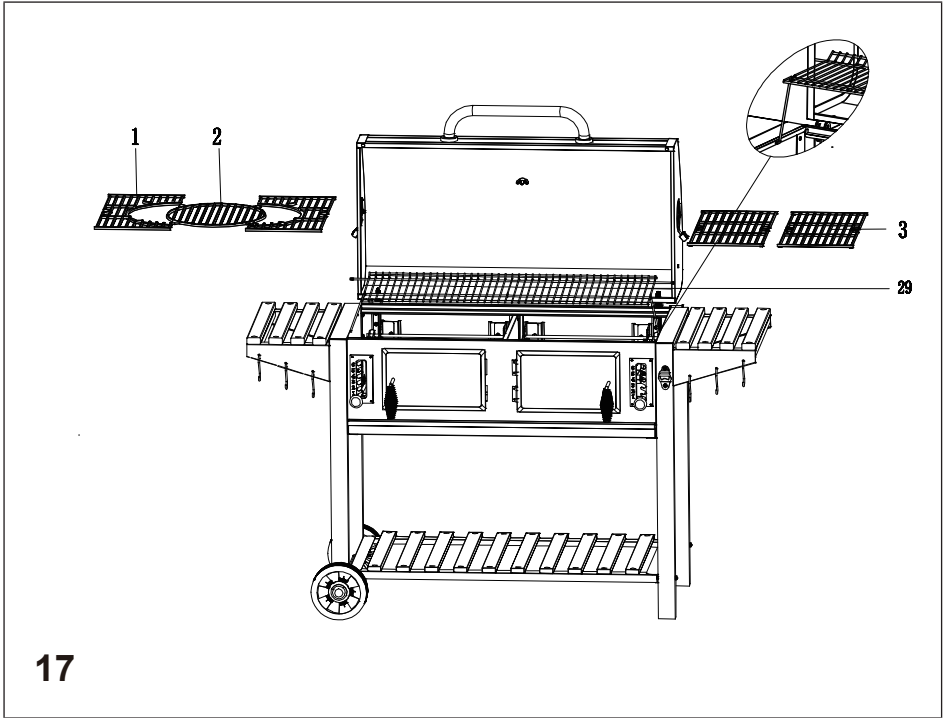





**KLARSTEIN**