



blumfeldt



Tommi

Kinderschreibtisch-Set XL

Children's Desk Set XL

Ensemble XL de bureau pour enfant

Juego de escritorio para niños XL

Set scrivania XL per bambini

10041861

10041866

Sehr geehrter Kunde,

wir gratulieren Ihnen zum Erwerb Ihrer Möbel. Lesen Sie die folgenden Hinweise sorgfältig durch und befolgen Sie diese, um möglichen Schäden vorzubeugen. Für Schäden, die durch Missachtung der Hinweise und unsachgemäßen Gebrauch entstehen, übernehmen wir keine Haftung. Scannen Sie den QR-Code, um Zugriff auf die aktuellste Bedienungsanleitung und weitere Informationen rund um das Produkt zu erhalten.



ARTIKEL

Artikelnummer	Ausführung
10041861	rosa
10041866	blau

SICHERHEITSHINWEISE

1. Die Möbel sind nur für den Gebrauch in Innenräumen vorgesehen.
2. Stellen Sie die Möbel auf einen flachen Untergrund.
3. Wenn Wasser, Öl oder andere Flüssigkeiten auf die Oberfläche gelangen, müssen sie sofort fortgewischt werden.
4. Überprüfen Sie die Verbindungen regelmäßig und ziehen Sie sie nach, wenn die Verschraubungen sich durch Erschütterungen gelockert haben.
5. Stellen Sie die Möbel nicht in der Umgebung von ätzenden Gasen und Feuchtigkeit auf, da dies zur Beschädigung der Oberflächen führt.
6. Ziehen Sie die Schrauben nicht zu fest, bevor Sie alle Schrauben angebracht haben.
7. Zur Reinigung der Schreibtischoberfläche ein feuchtes Tuch verwenden.

LIEFERUMFANG

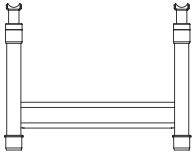

B1



B2x2

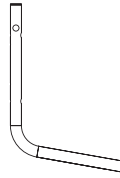

B3

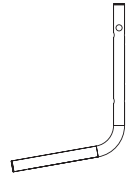

B4



B5

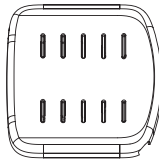

B6



B7

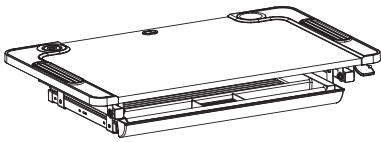

B8

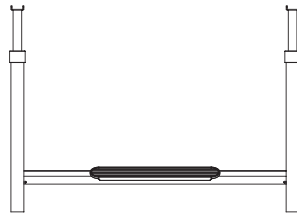

B9



B10x2



A1x8



A2x16
M6x20



A3x8



A4x4
ST4.8x25



A5x2



A6x1



A7x1



A8x1

MONTAGE STUHL

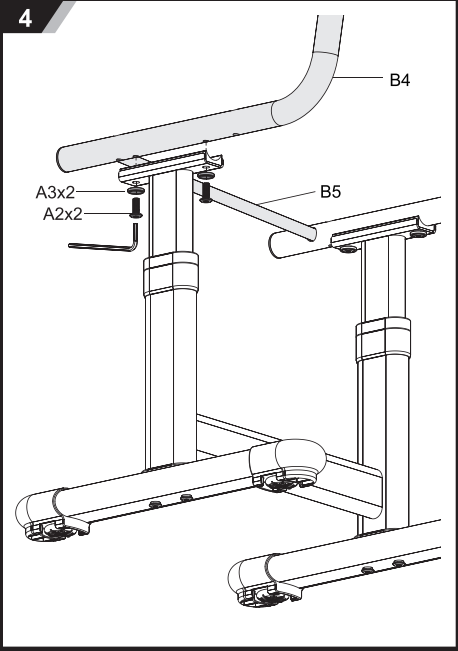
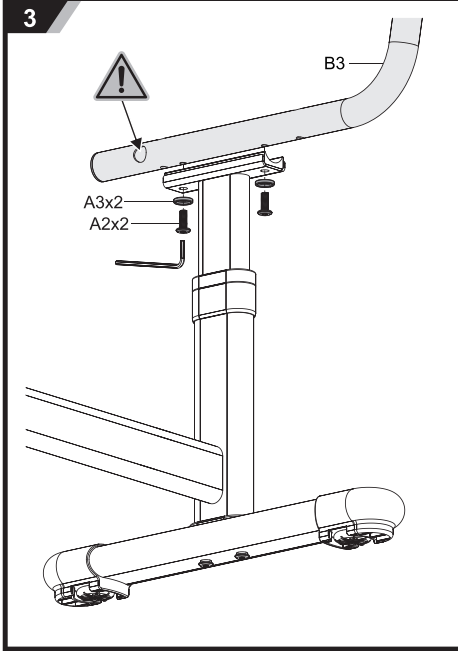
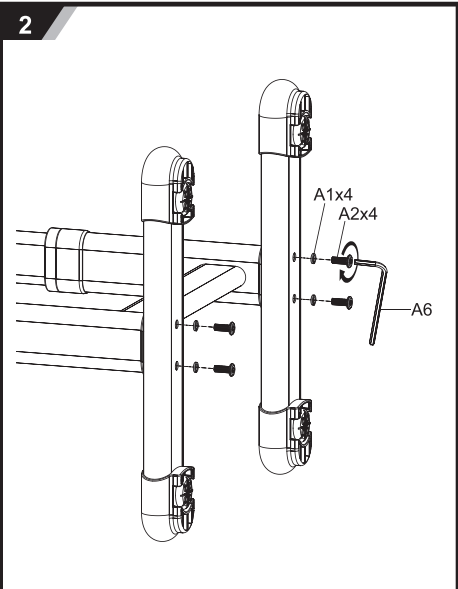
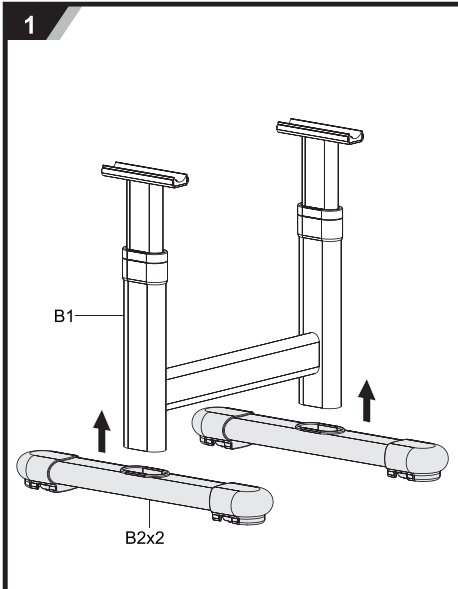

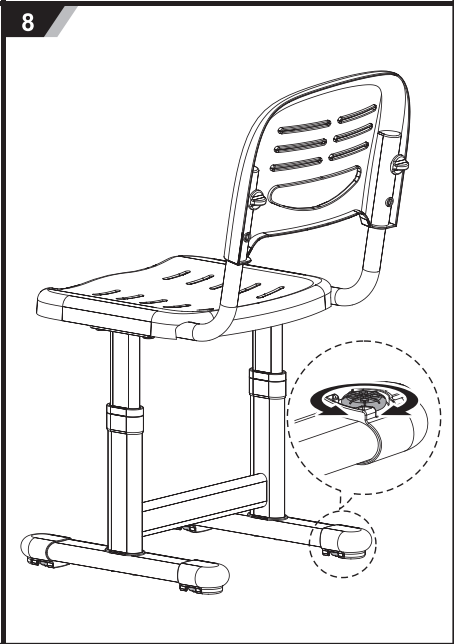
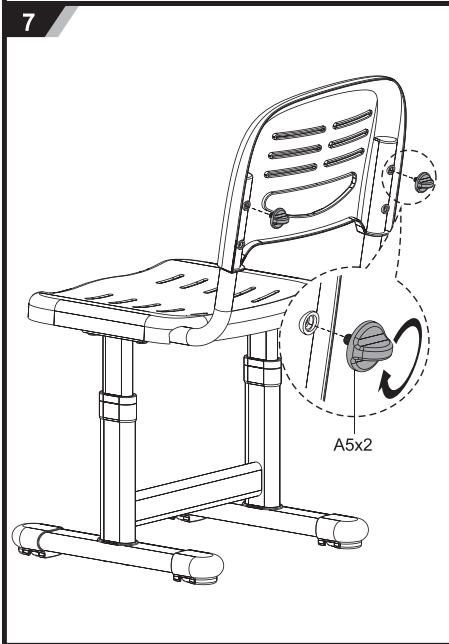
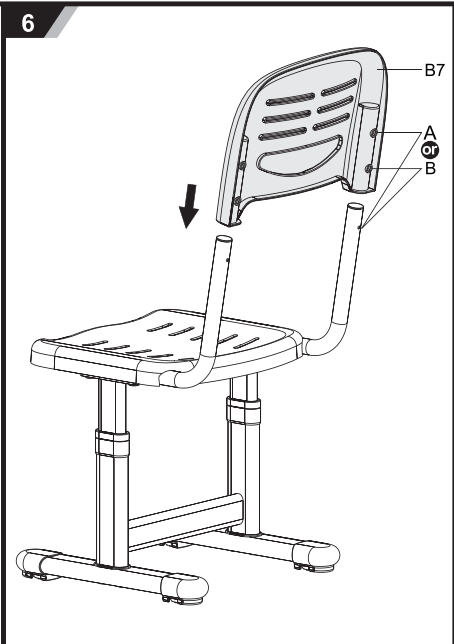
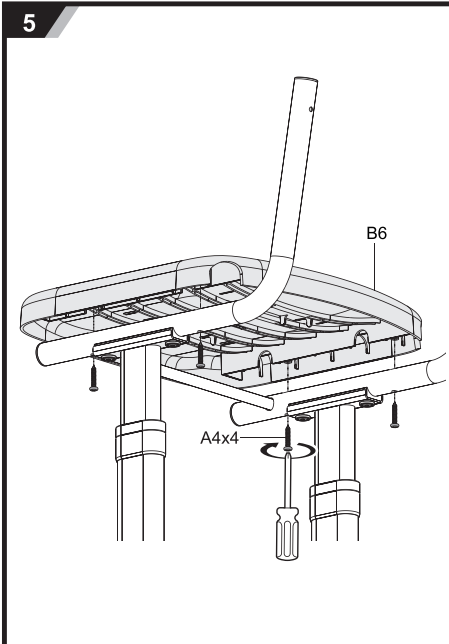

MONTAGE ARBEITSTISCH

9

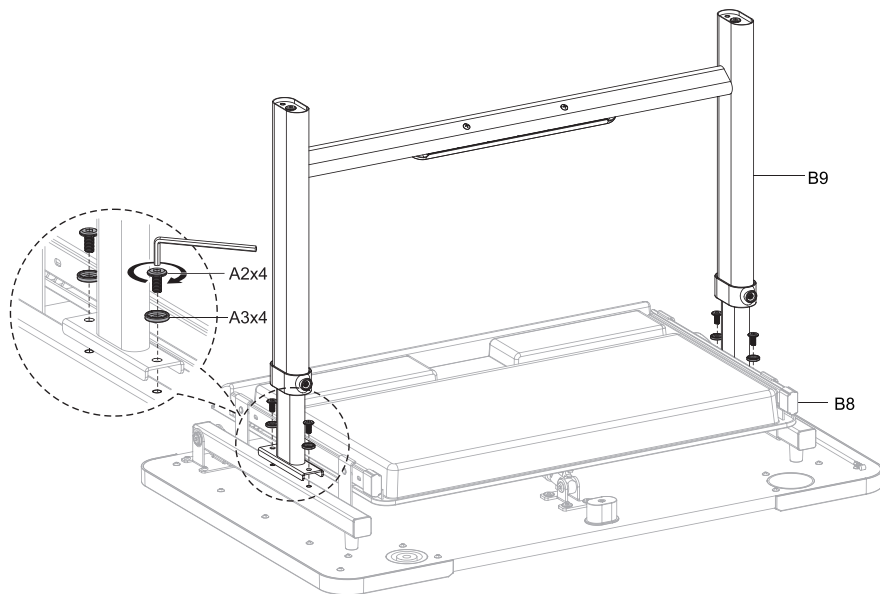

10

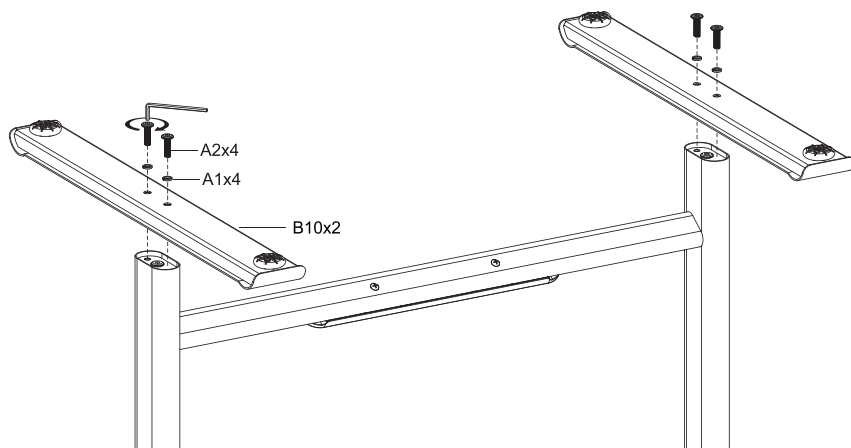

11

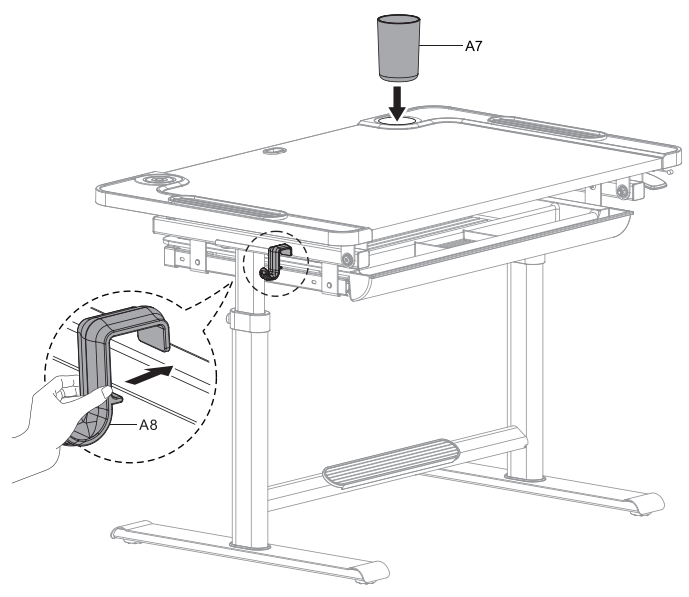

12

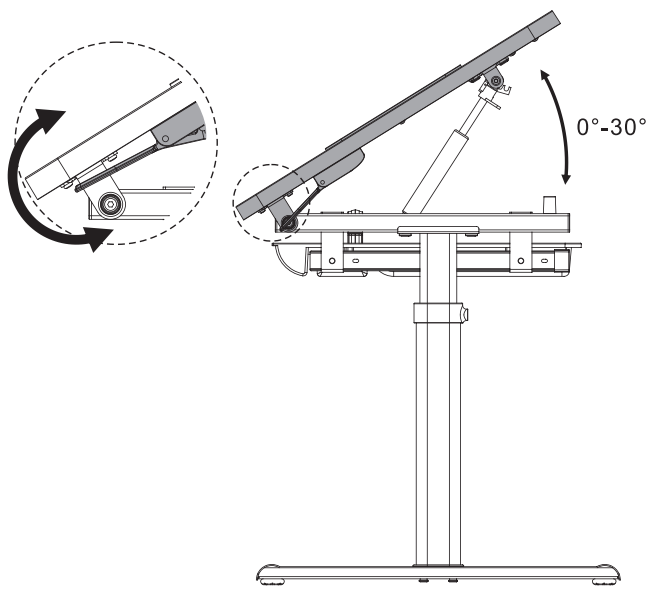

EINSTELLUNG DER HÖHE

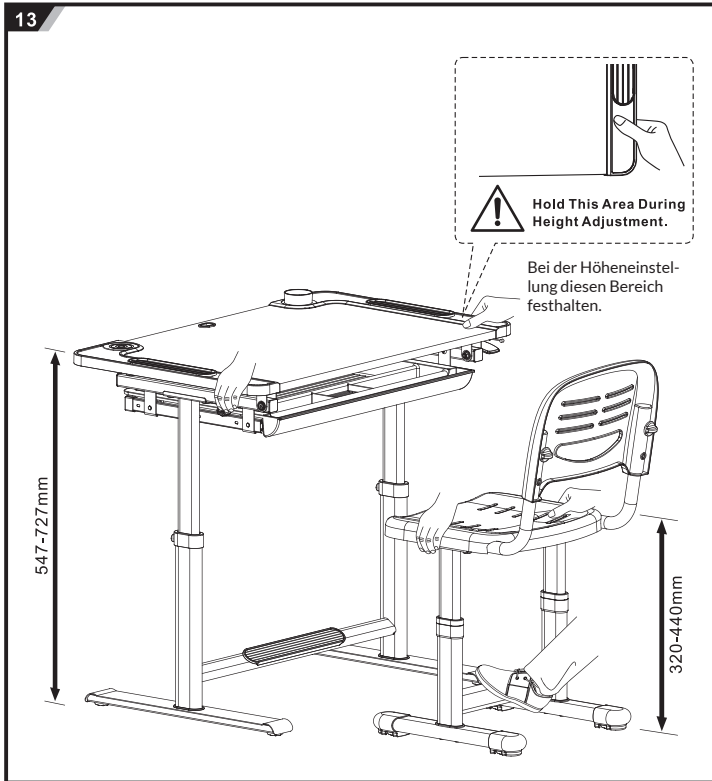

Tischplatte und Stuhl höher stellen

Die Tischplatte und der Stuhl können durch Hochziehen höher gestellt werden. Auf das Tisch- bzw. Stuhlein treten und auf die gewünschte Höhe hoch ziehen.

Niedriger stellen

Auf die maximale Höhe stellen und dann zur niedrigsten Position senken. Nun wieder auf die gewünschte Höhe hochstellen.

Empfohlene Einstellungen für jeweilige Körpergrößen

Diese Einstellungen sind Empfehlungen. Die jeweilige Höhe muss individuell angepasst werden.

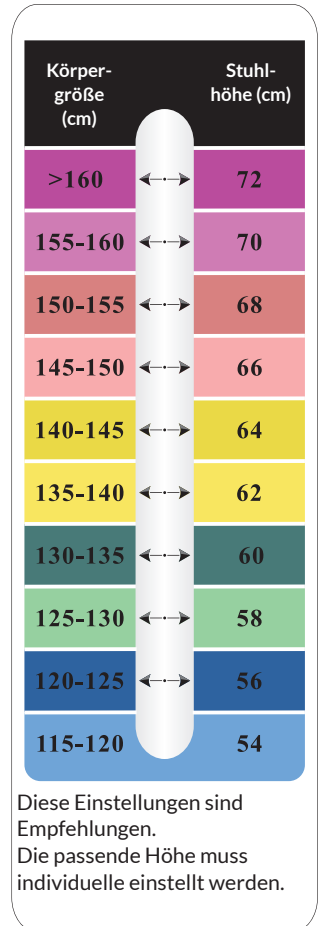
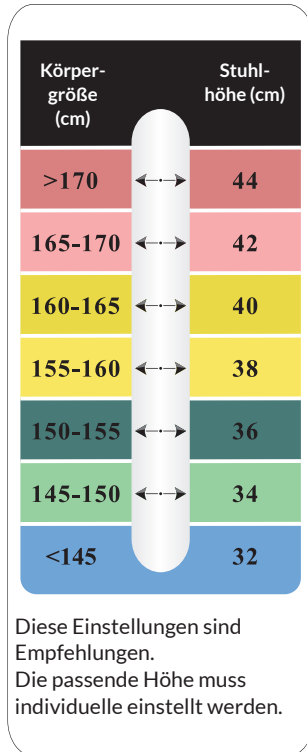

Dear Customer,

Congratulations on purchasing this piece of furniture. Please read this manual carefully and take care of the following hints on installation and use to avoid technical damages. Any failure caused by ignoring the items and cautions mentioned in the operation and installation instructions are not covered by our warranty and any liability. Scan the QR code to get access to the latest user manual and more product information.



ARTICLE

Item number	Style
10041861	pink
10041866	blue

SAFETY INSTRUCTIONS

1. This product is intended for indoor use only.
2. This product should be placed on the flat ground.
3. Once water, oil and other liquid adhere to the surface of product, you should quickly wipe it clean.
4. Please regularly check and fasten joint parts in case of product shake and loosening.
5. Do not lay product in place of the corrosive gas and moisture in case of surface damage
6. Never fasten screws tightly before all screws.
7. Please use damp cloth to clean the desktop.

SCOPE OF SUPPLY

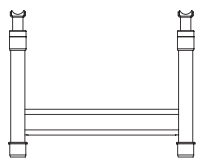

B1



B2x2

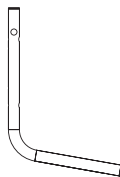

B3

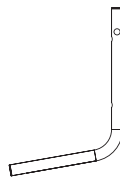

B4



B5

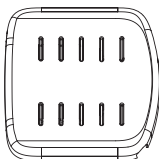

B6



B7

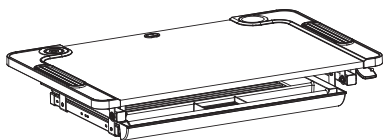

B8

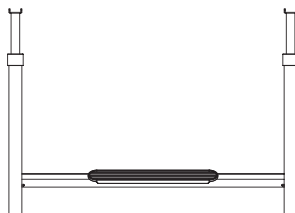

B9



B10x2



A1x8



A2x16
M6x20



A3x8



A4x4
ST4.8x25



A5x2



A6x1



A7x1



A8x1

CHAIR ASSEMBLY

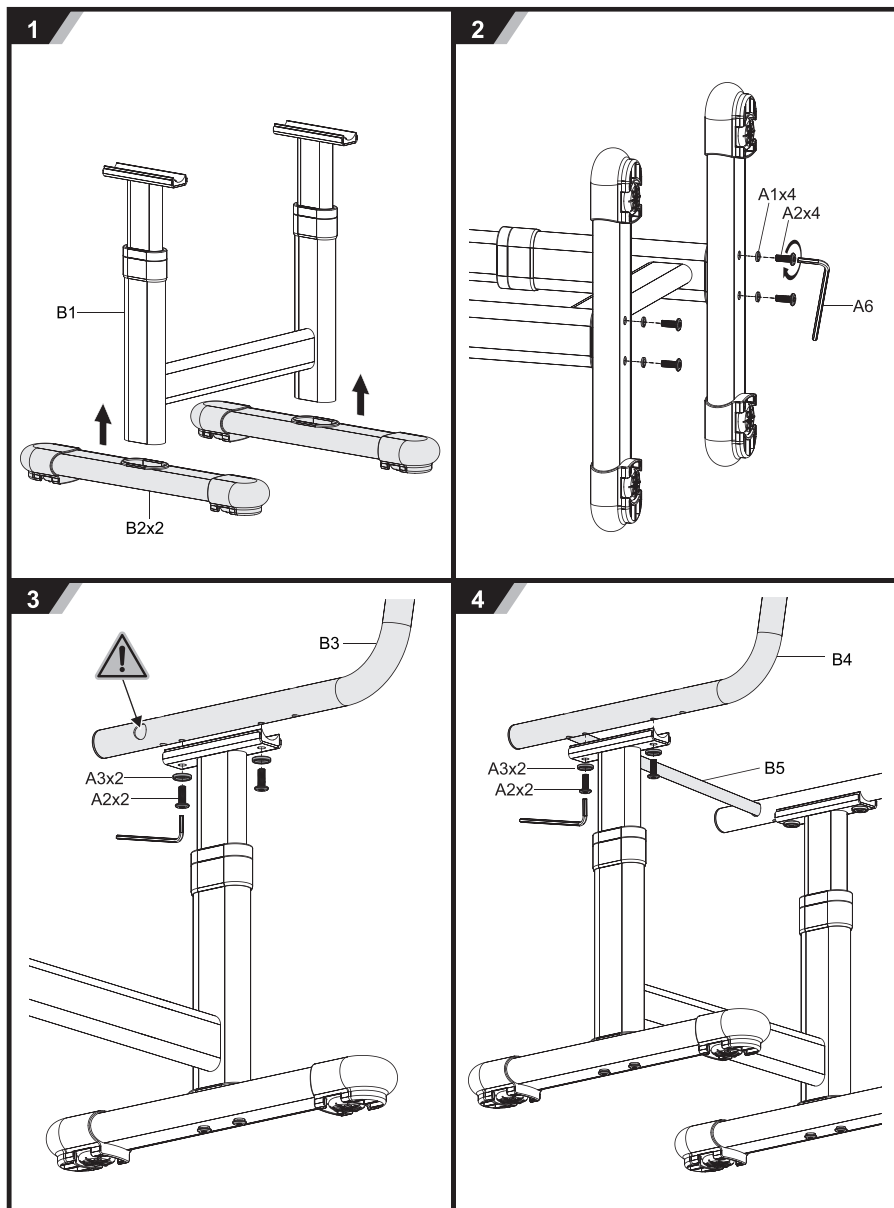

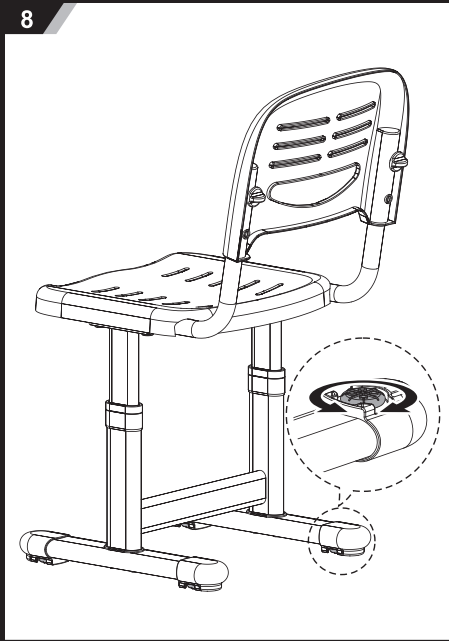
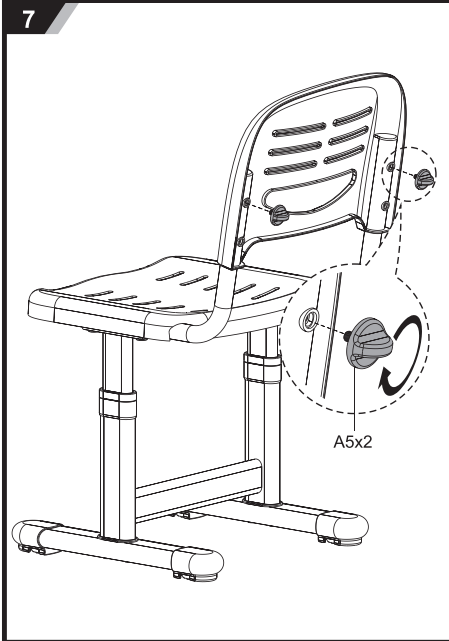
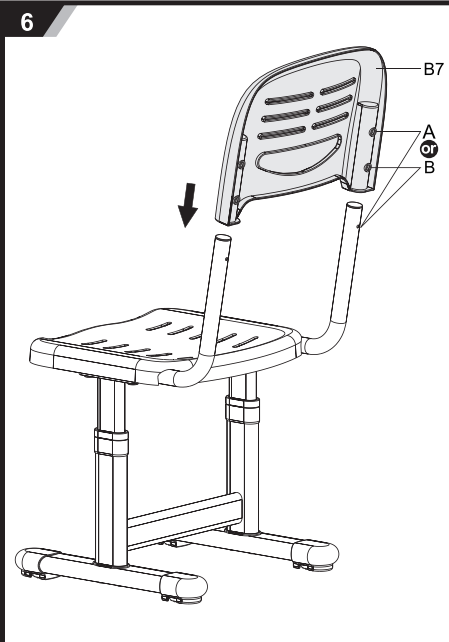
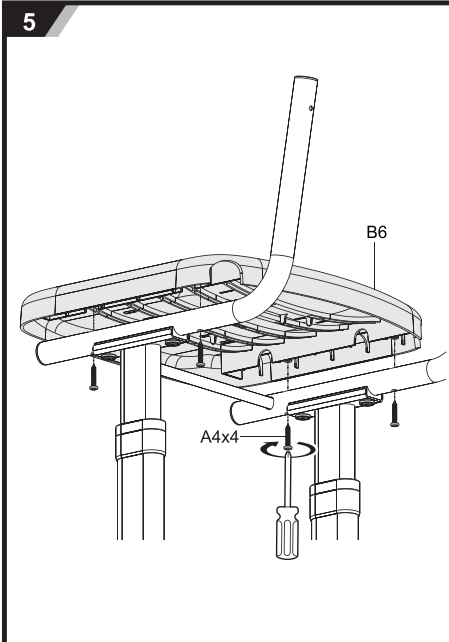

DESK ASSEMBLY

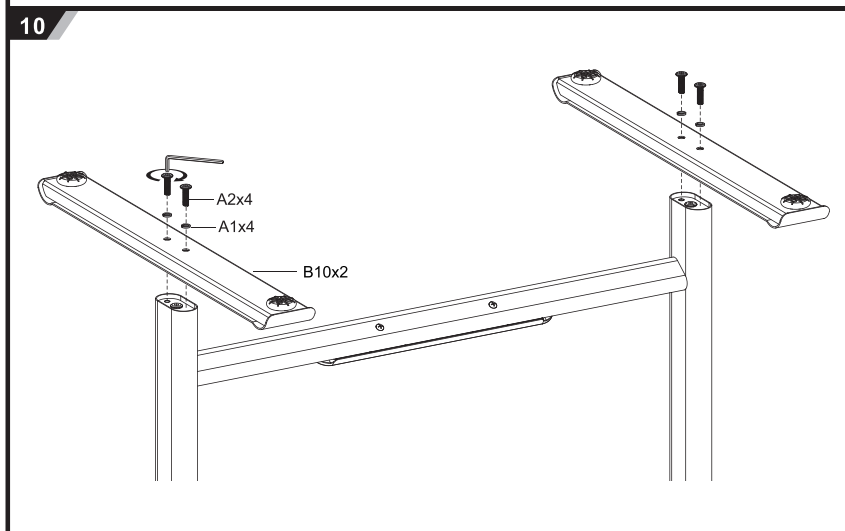
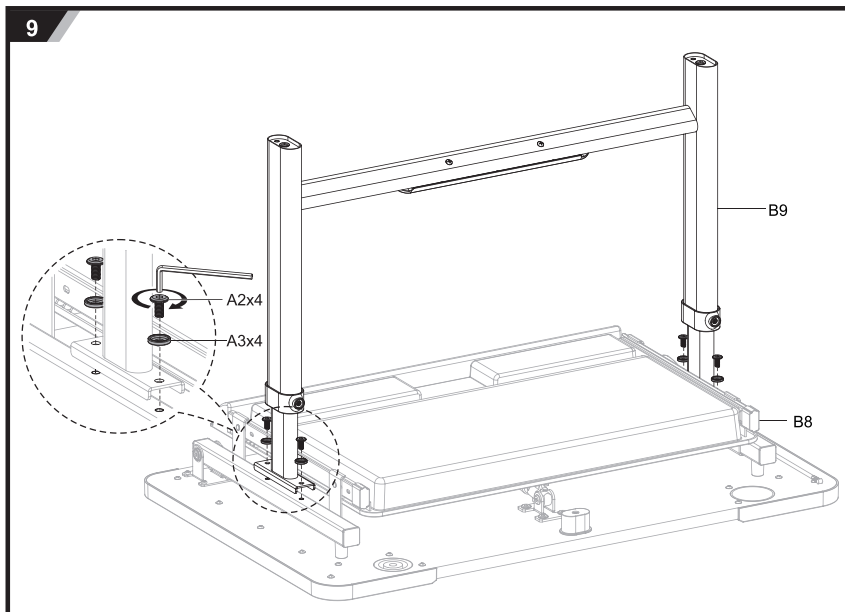

11

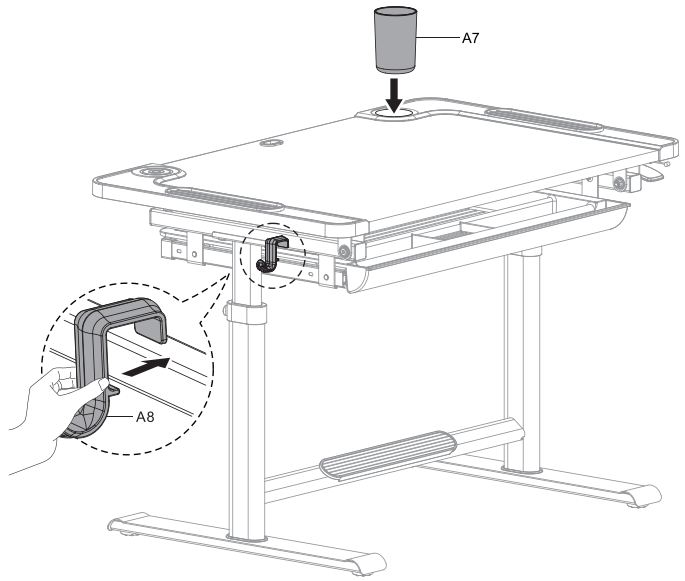

12

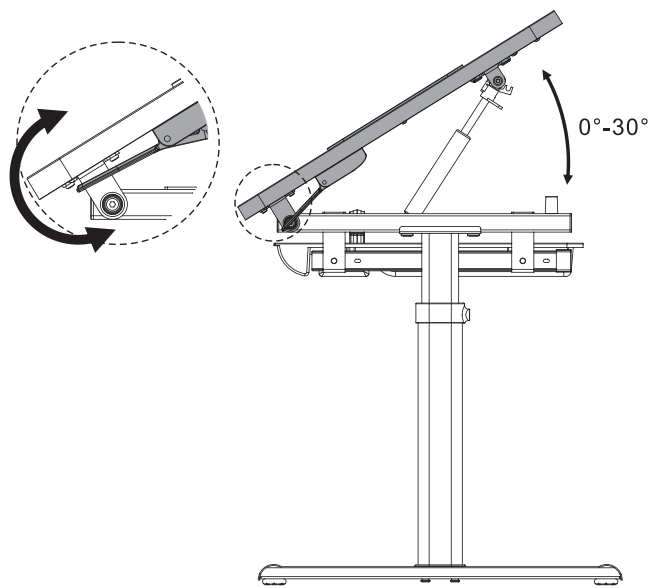

13

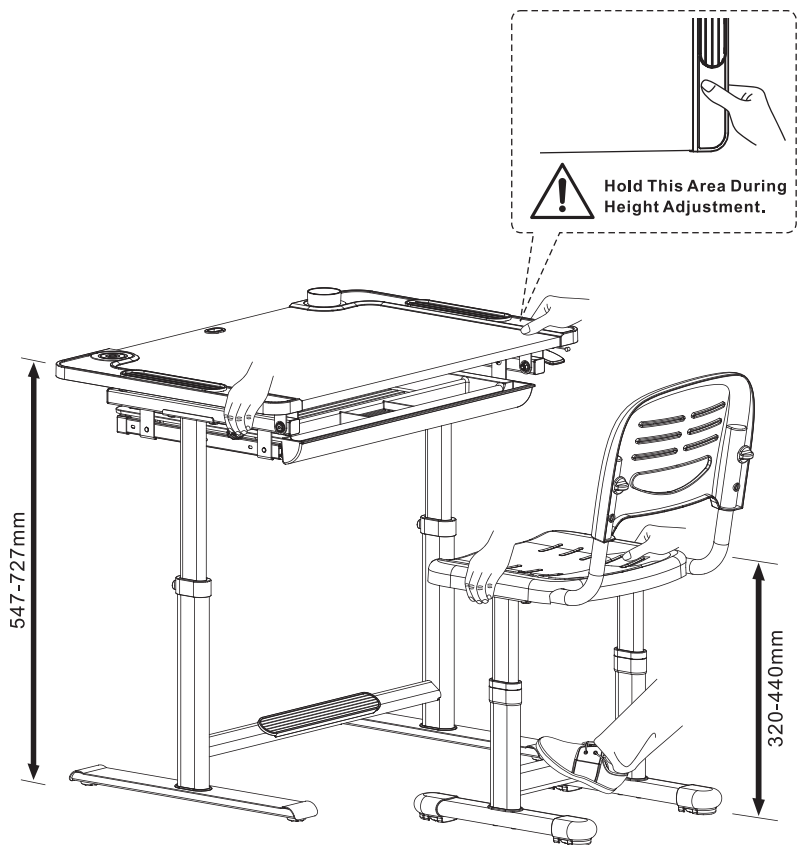

HEIGHT ADJUSTMENT

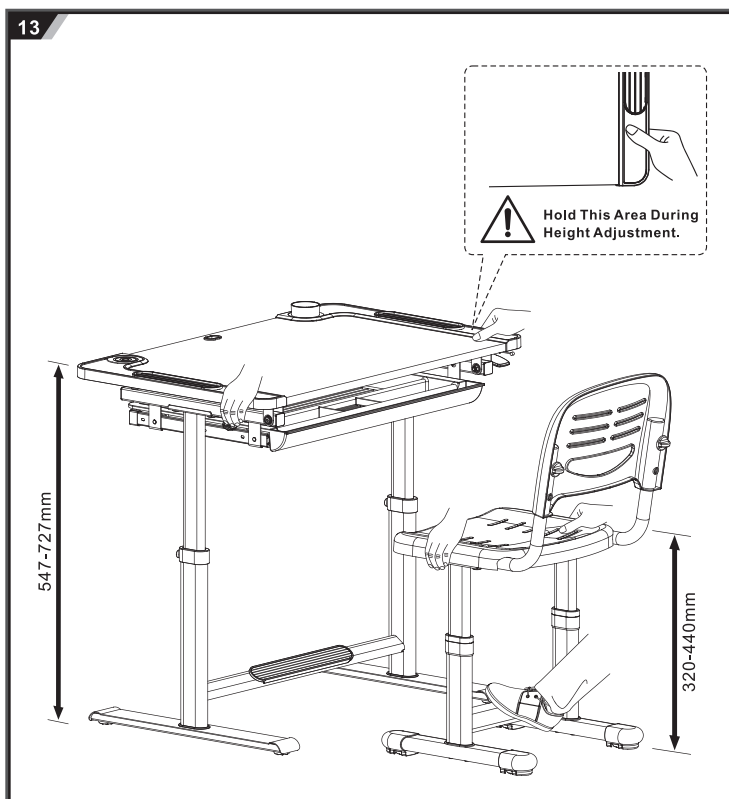

How to lift up

Desk and chair can be adjusted higher by direct pulling up. Step on the support bar with one foot and pull up desk/chair to the height needed.

How to lower down

Pull to the max height and slowly lower down to the minimum height. Pull up again to the height needed.

Recommended height adjustments depending on body height

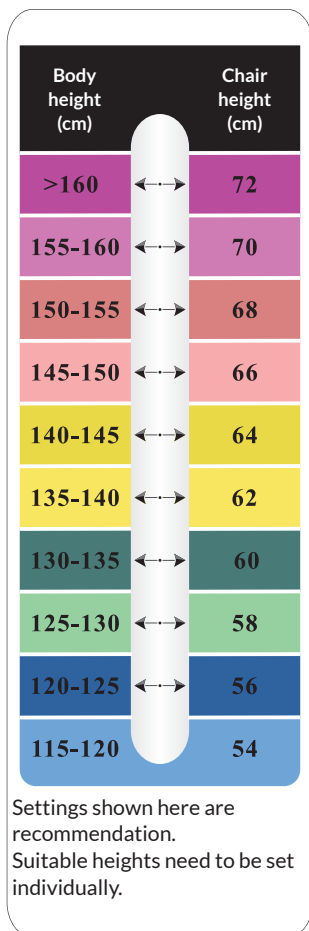
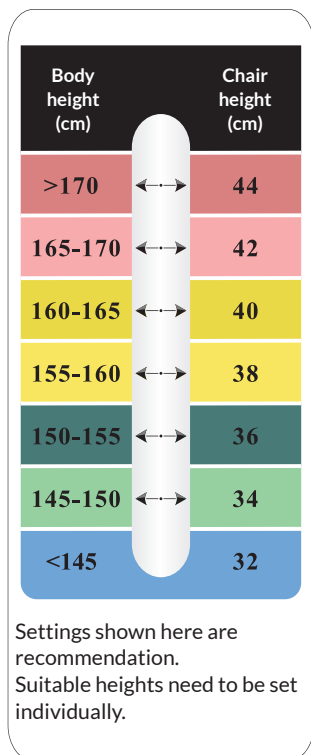

Cher client, chère cliente,

Toutes nos félicitations pour l'acquisition de ce meuble. Lisez attentivement les indications suivantes et suivez-les pour éviter d'éventuels dommages. Nous ne saurions être tenus pour responsables des dommages dus au non-respect des consignes et à la mauvaise utilisation de l'appareil. Scannez le QR-Code pour obtenir la dernière version du mode d'emploi ainsi que d'autres informations concernant le produit.



ARTICLE

Numéro d'article	Version
10041861	rose
10041866	Bleu

CONSIGNES DE SÉCURITÉ

1. Les meubles sont destinés à être utilisés uniquement à l'intérieur.
2. Placez le meuble sur une surface plane et propre.
3. Si de l'eau, de l'huile ou d'autres liquides se répandent sur la surface, essuyez-les immédiatement.
4. Vérifiez régulièrement les connexions et resserrez-les si les raccords se sont desserrés sous l'effet de secousses.
5. Ne placez pas les meubles à proximité de gaz corrosifs ou d'humidité, car cela pourrait endommager les surfaces.
6. Ne serrez pas trop les vis avant de les avoir toutes mises en place.
7. Pour nettoyer la surface du bureau, utilisez un chiffon humide.

CONTENU DE L'EMBALLAGE

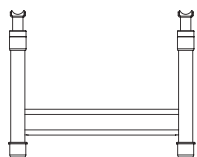

B1



B2x2

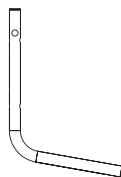

B3

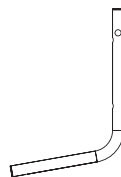

B4



B5

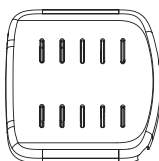

B6

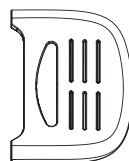

B7

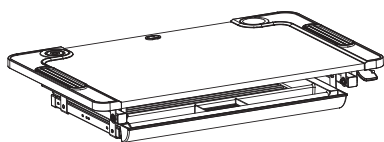

B8

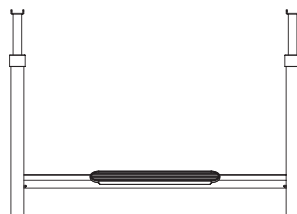

B9



B10x2



A1x8

A2x16
M6x20

A3x8

A4x4
ST4.8x25

A5x2



A6x1



A7x1



A8x1

MONTAGE DE LA CHAISE

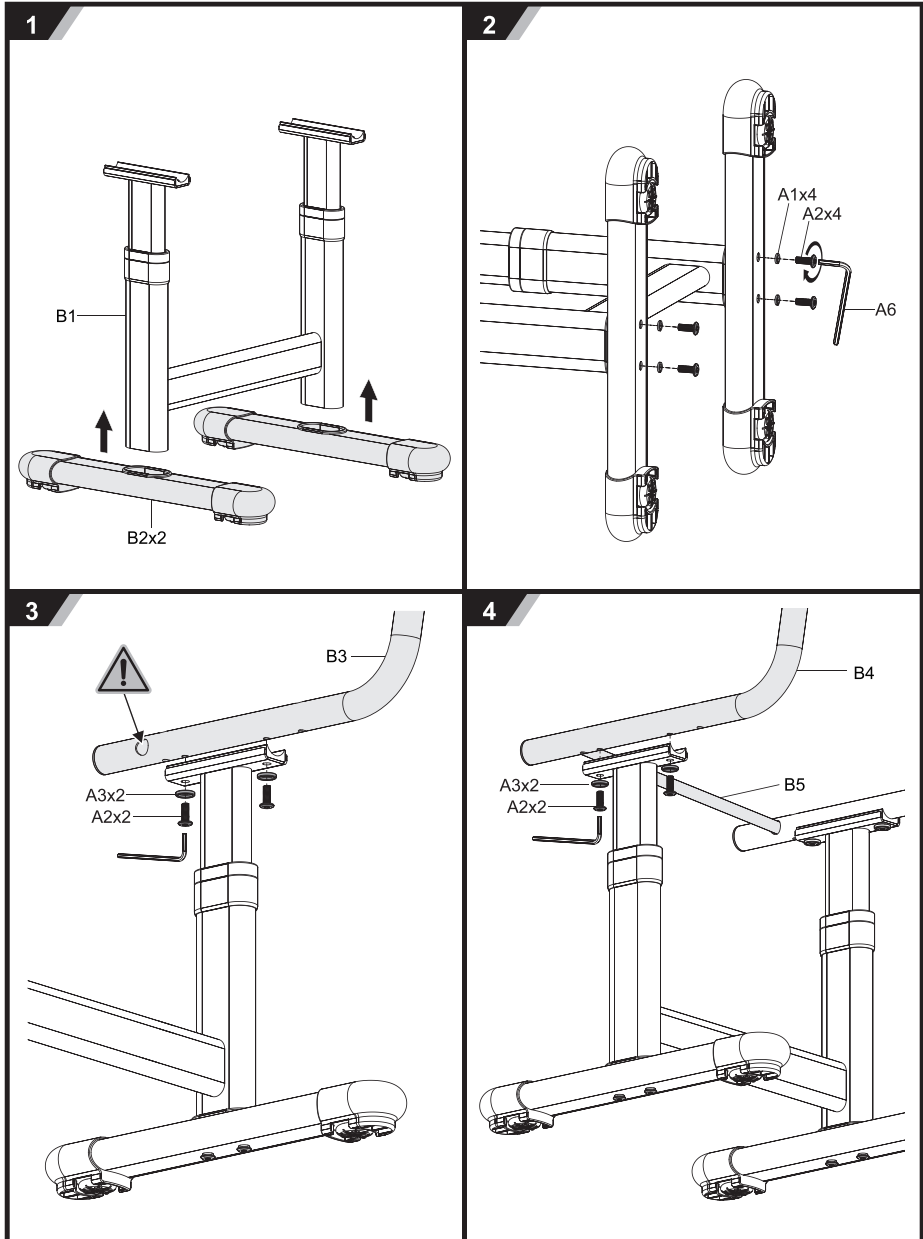

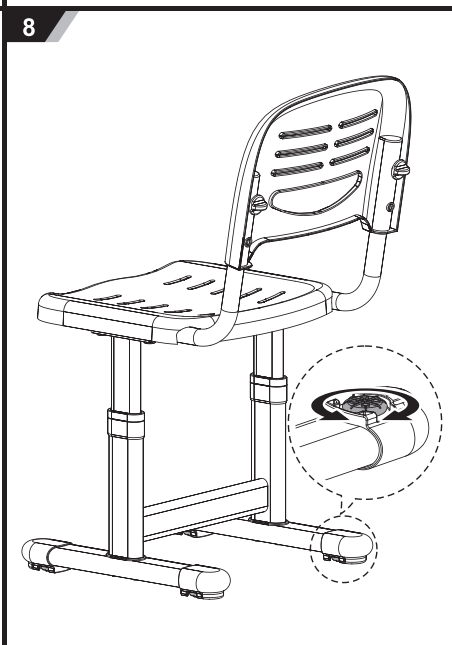
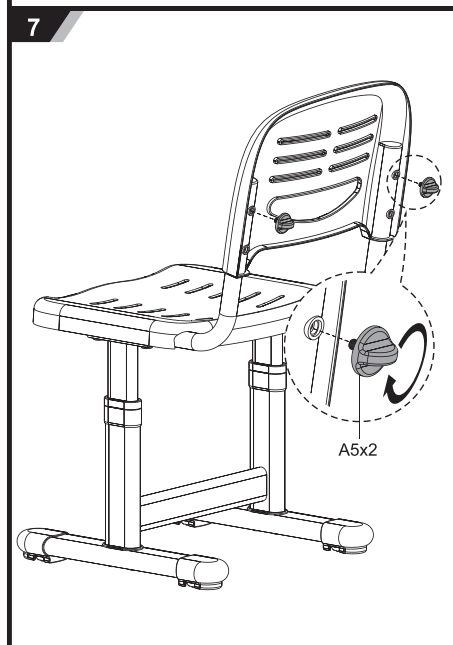
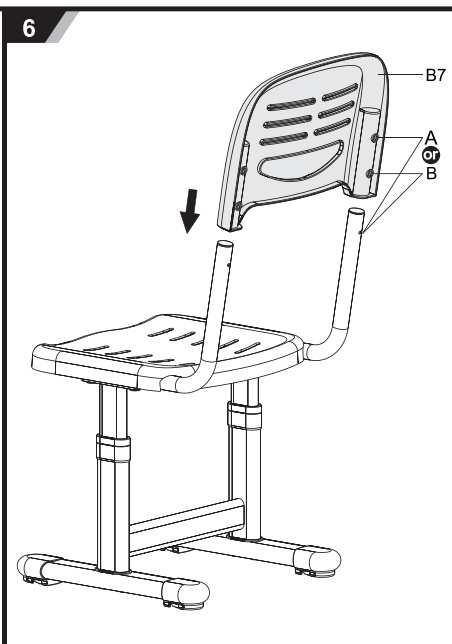
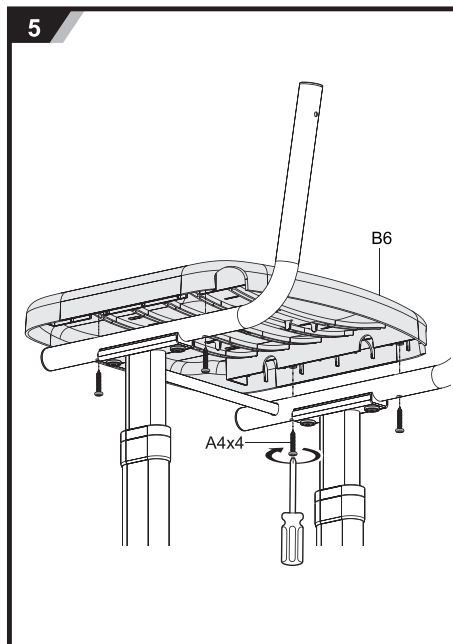

MONTAGE DU BUREAU

9

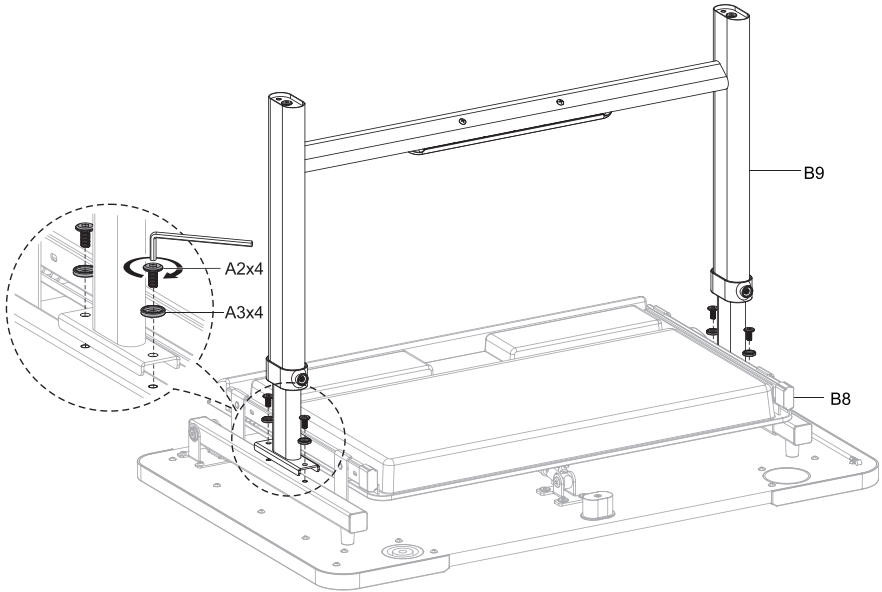

10

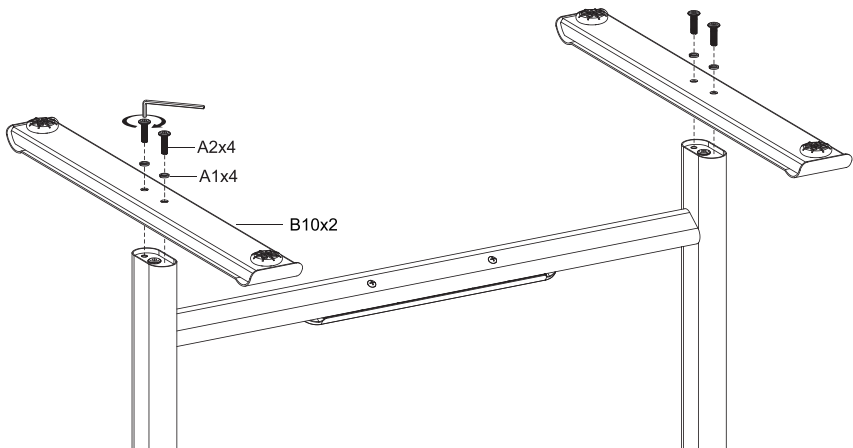

11

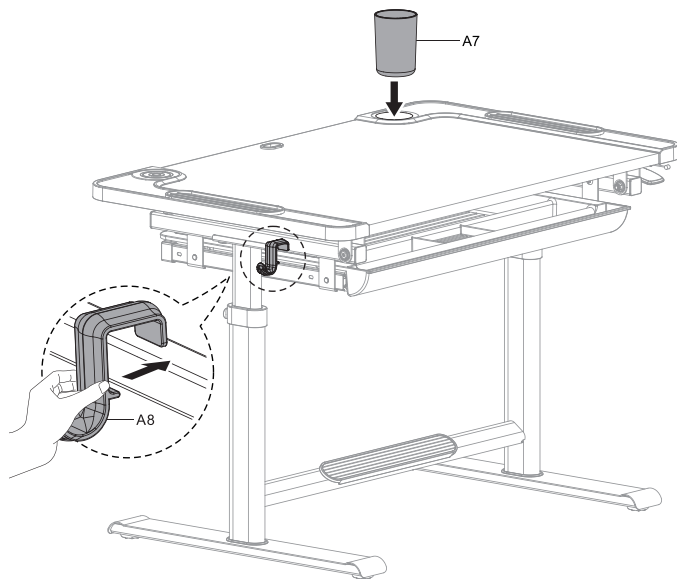

12

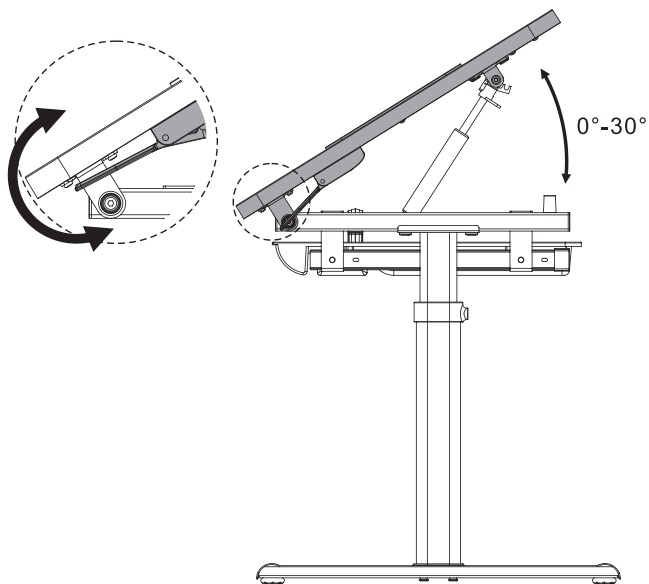

RÉGLAGE DE LA HAUTEUR

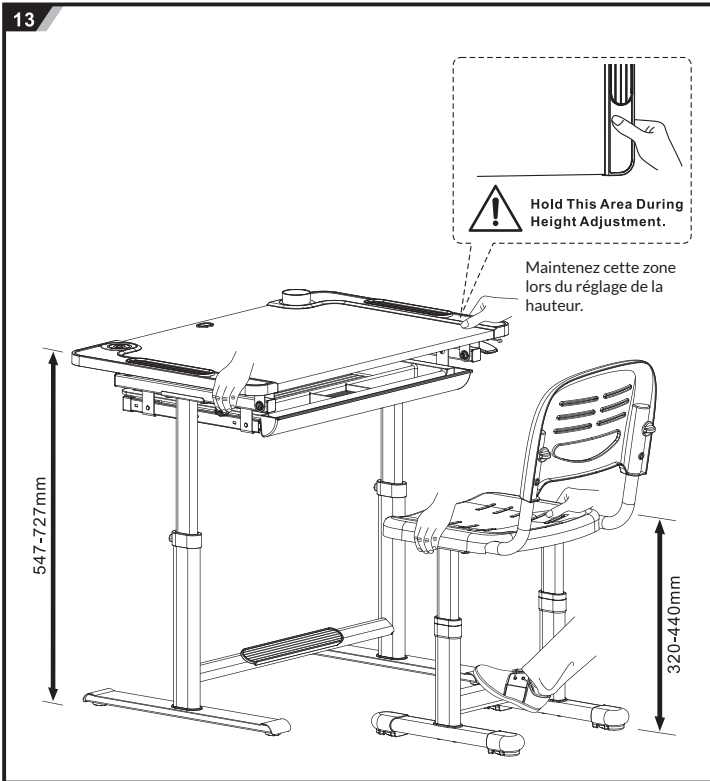

Relevez le plateau de la table et la chaise

Le plateau de la table et la chaise peuvent être surélevés en les tirant vers le haut. Montez sur la petite table ou la petite chaise et tirez-la vers le haut à la hauteur souhaitée.

Pour abaisser la hauteur

Mettez-la à la hauteur maximale, puis abaissez-la à la position la plus basse. Remontez maintenant à la hauteur souhaitée.

Réglages recommandés pour chaque taille

Ces réglages sont des recommandations. La hauteur doit être adaptée individuellement.

Taille (cm)		Hauteur de la chaise (cm)
>170	↔	44
165-170	↔	42
160-165	↔	40
155-160	↔	38
150-155	↔	36
145-150	↔	34
<145		32

Ces réglages sont des recommandations.
La hauteur appropriée doit être réglée individuellement.

Taille (cm)		Hauteur de la chaise (cm)
>160	↔	72
155-160	↔	70
150-155	↔	68
145-150	↔	66
140-145	↔	64
135-140	↔	62
130-135	↔	60
125-130	↔	58
120-125	↔	56
115-120		54

Ces réglages sont des recommandations.
La hauteur appropriée doit être réglée individuellement.

Estimado cliente:

Le felicitamos por la compra de su mueble. Lea atentamente el siguiente manual y siga cuidadosamente las instrucciones de uso con el fin de evitar posibles daños. La empresa no se hace responsable de los daños causados por el incumplimiento de las instrucciones y el uso indebido. Escanee el siguiente código QR para acceder al último manual de usuario y a más información sobre el producto.



ARTÍCULO

Número del artículo	Versión
10041861	rosa
10041866	Azul

INDICACIONES DE SEGURIDAD

1. El mueble está destinado únicamente a su uso en interiores.
2. Coloque el mueble en una superficie plana y limpia.
3. Si el agua, el aceite u otros líquidos entran en contacto con la superficie, deben limpiarse inmediatamente.
4. Compruebe regularmente las conexiones y apriételas si las uniones roscadas se han aflojado debido a las vibraciones.
5. No coloque el mueble en la proximidad de gases corrosivos o humedad, ya que esto dañará las superficies.
6. No apriete demasiado los tornillos antes de haber colocado todos los tornillos.
7. Utilice un paño húmedo para limpiar la superficie del escritorio.

CONTENIDO DEL ENVÍO

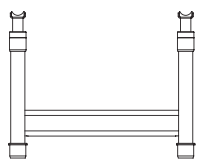

B1



B2x2

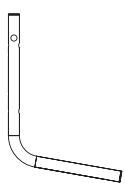

B3

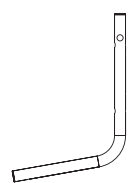

B4



B5

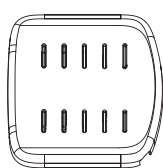

B6

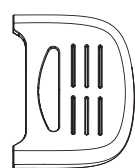

B7

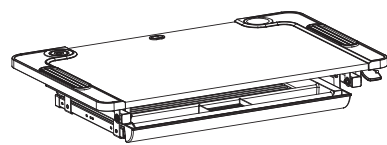

B8

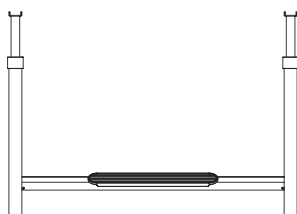

B9



B10x2



A1x8



A2x16
M6x20



A3x8



A4x4
ST4.8x25



A5x2



A6x1



A7x1



A8x1

MONTAJE DE LA SILLA

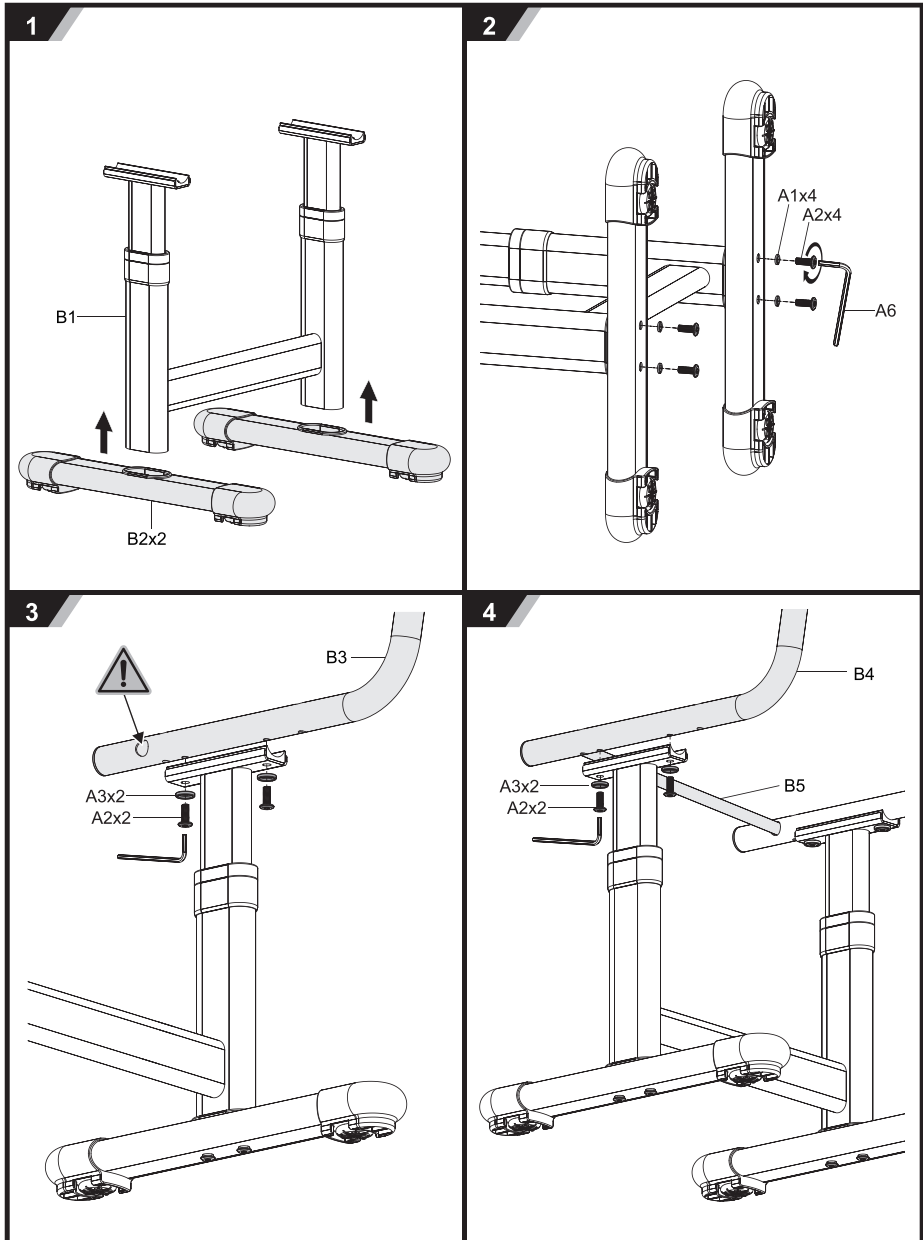

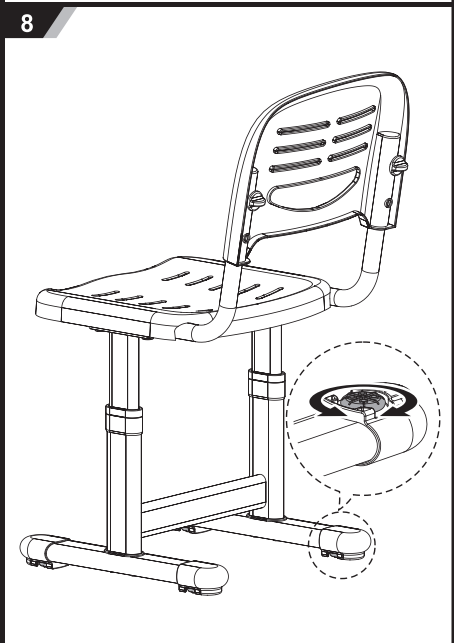
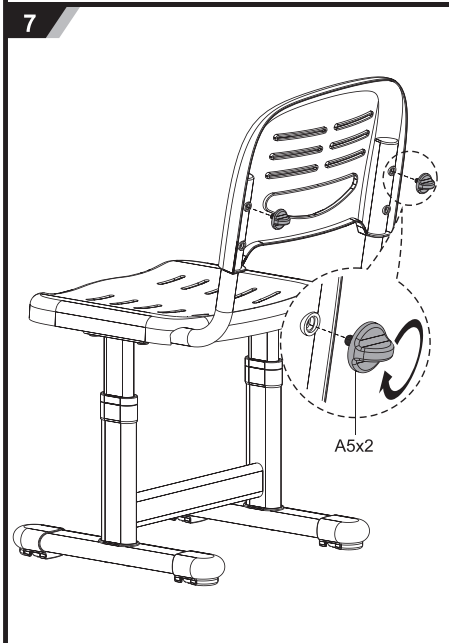
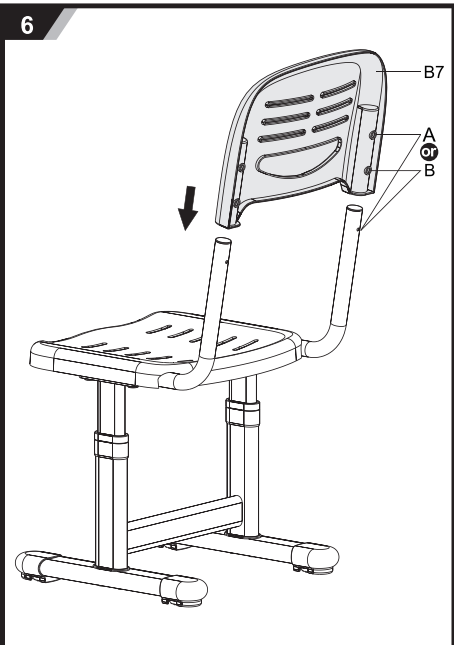
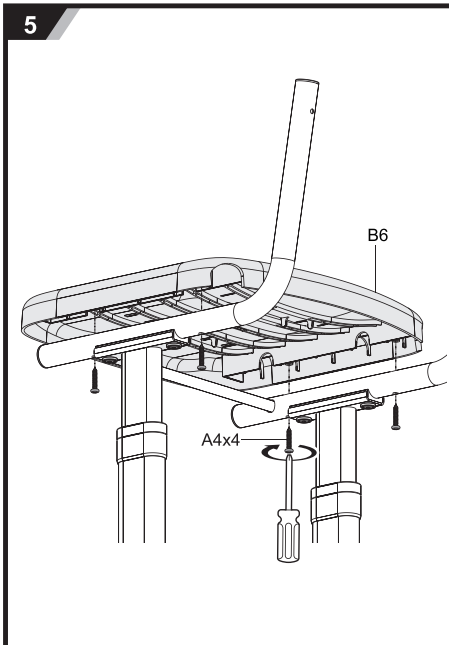

MONTAJE DE LA MESA DE TRABAJO

9

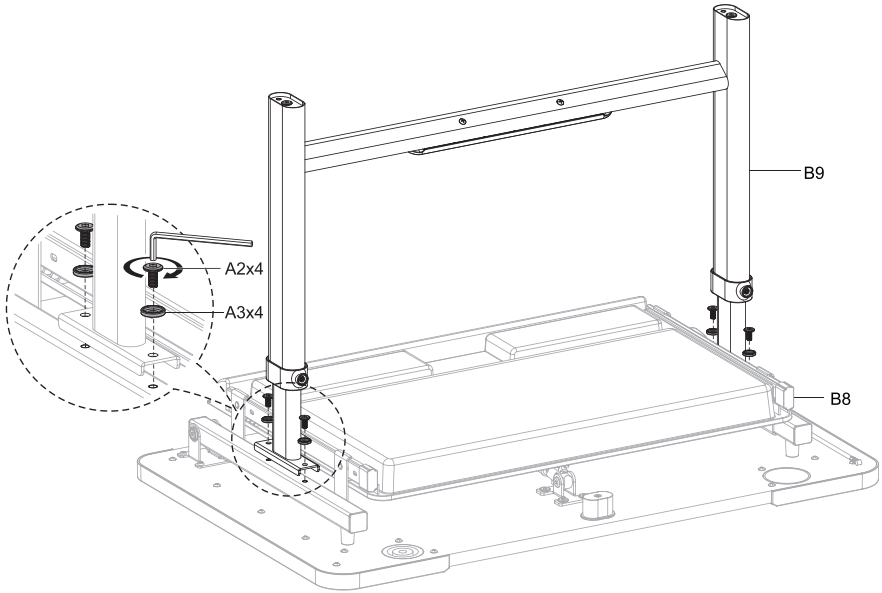

10

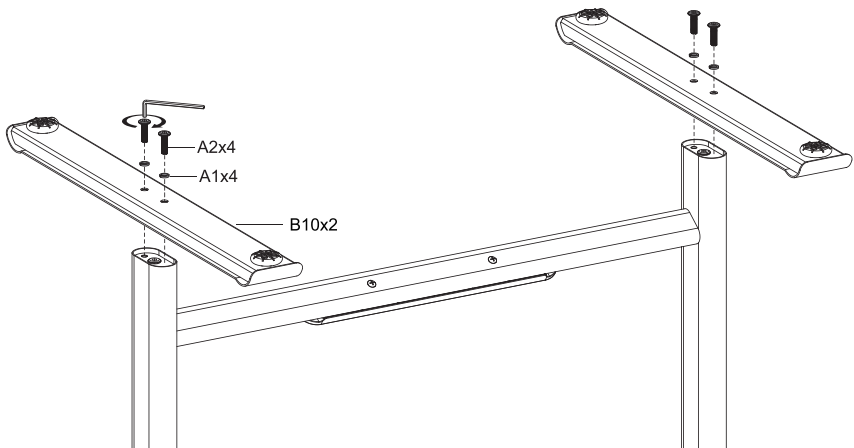

11

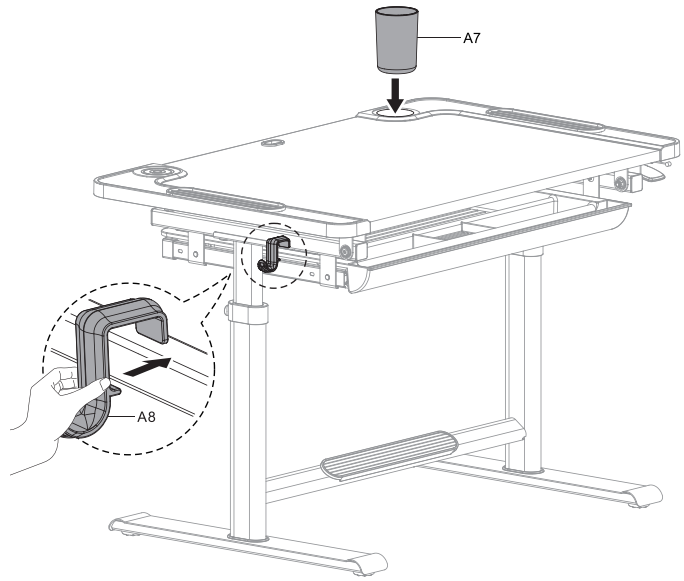

12

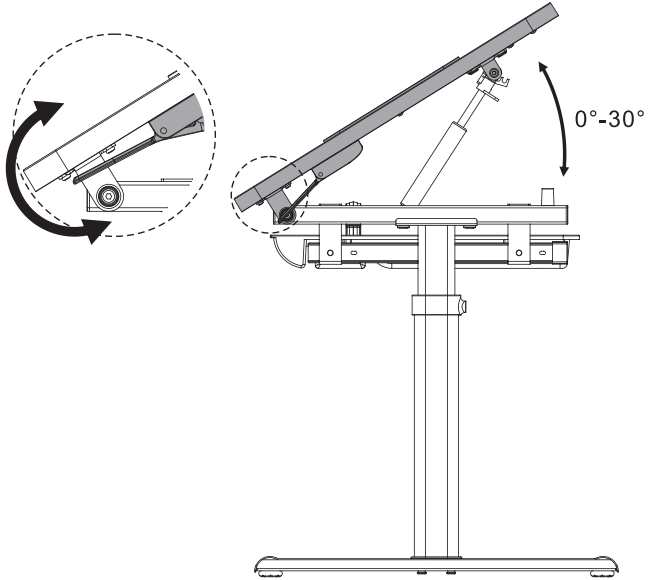

AJUSTE DE LA ALTURA

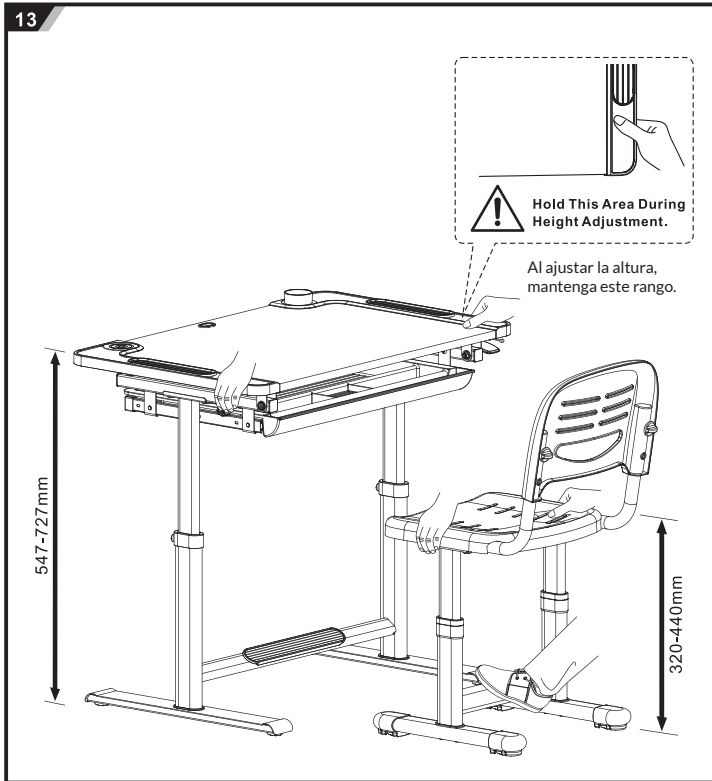

Levanta el tablero y la silla

El tablero de la mesa y la silla pueden levantarse tirando de ellos. Sube la mesa o a la silla a la altura deseada.

Establecer un nivel más bajo

Colóquelo a la altura máxima y luego bájelo a la posición más baja. Ahora vuelva a subirlo a la altura deseada.

Ajustes recomendados para cada tamaño de cuerpo

Estos ajustes son recomendaciones. La altura respectiva debe ajustarse individualmente.

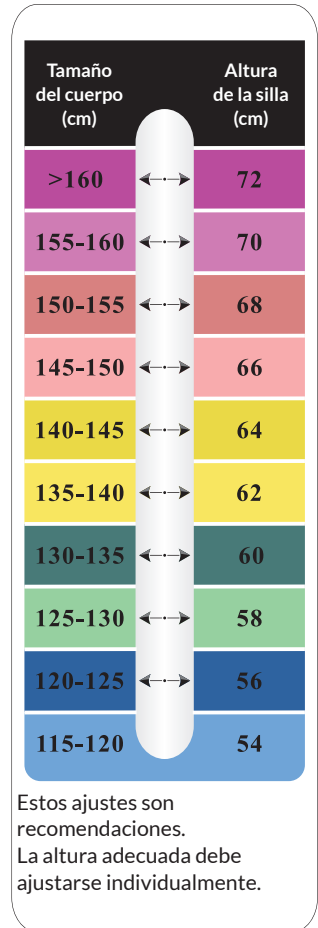
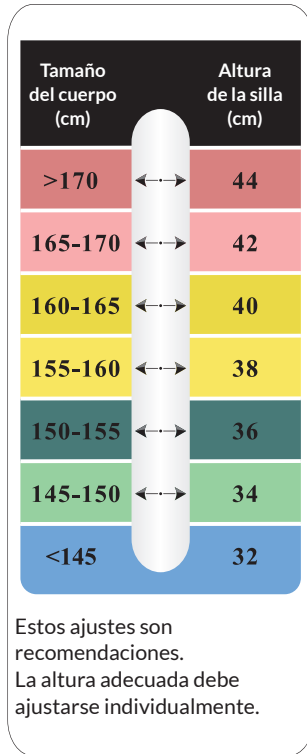

Gentile cliente,

la ringraziamo per l'acquisto del set di mobili. La preghiamo di leggere attentamente le seguenti indicazioni e di seguirle per evitare eventuali danni. Non ci assumiamo alcuna responsabilità per danni scaturiti da una mancata osservanza delle avvertenze di sicurezza e da un uso improprio del dispositivo. Scansionare il codice QR seguente per accedere al manuale d'uso più attuale e per ricevere informazioni sul prodotto.



ARTICOLO

Numero articolo	Versione
10041861	rosa
10041866	blu

AVVERTENZE DI SICUREZZA

1. I mobili sono destinati esclusivamente all'uso interno.
2. Posizionare i mobili su una superficie piana.
3. Se acqua, olio o altri liquidi si depositano sulla superficie, devono essere rimossi immediatamente con un panno.
4. Controllare regolarmente i collegamenti e serrarli se le viti si sono allentate a causa di movimenti e vibrazioni.
5. Non posizionare i mobili in prossimità di gas corrosivi e umidità per non danneggiare le superfici.
6. Non stringere troppo le viti prima di averle installate tutte.
7. Utilizzare un panno umido per pulire la superficie della scrivania.

VOLUME DI CONSEGNA

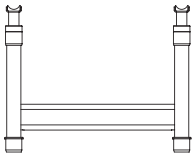

B1



B2x2

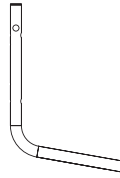

B3

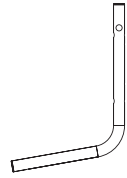

B4



B5

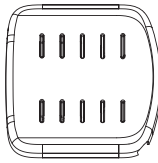

B6

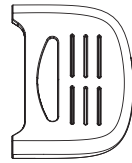

B7

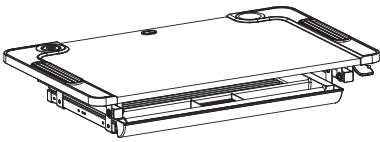

B8

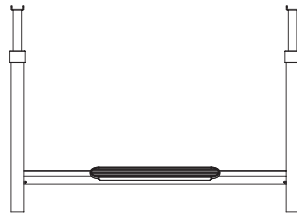

B9



B10x2



A1x8



A2x16
M6x20



A3x8



A4x4
ST4.8x25



A5x2



A6x1



A7x1



A8x1

MONTAGGIO DELLA SEDIA

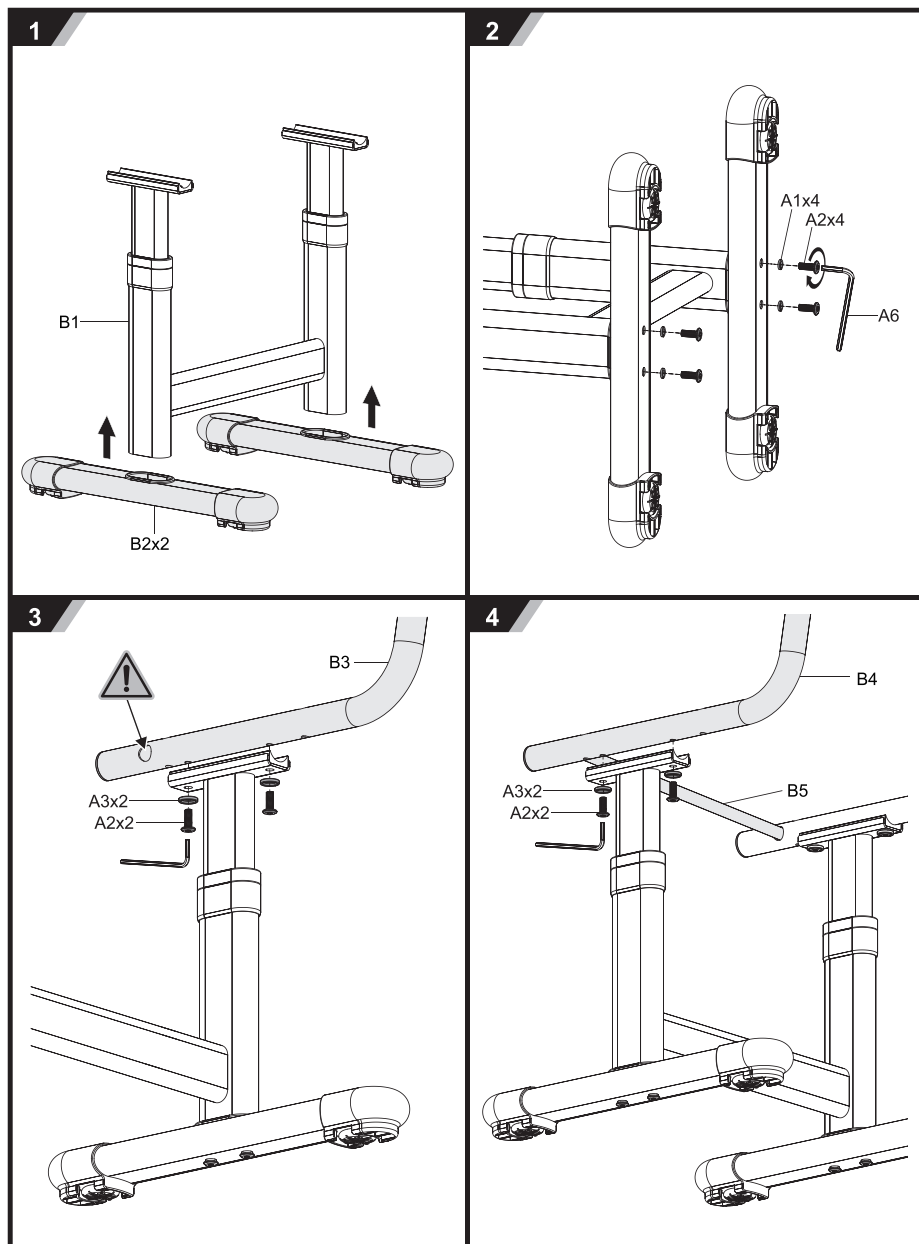

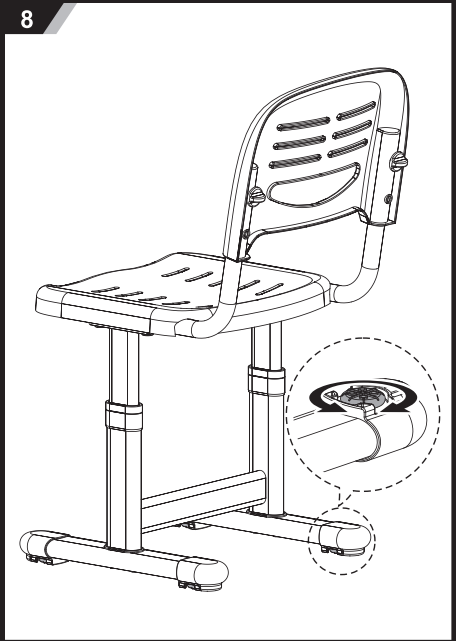
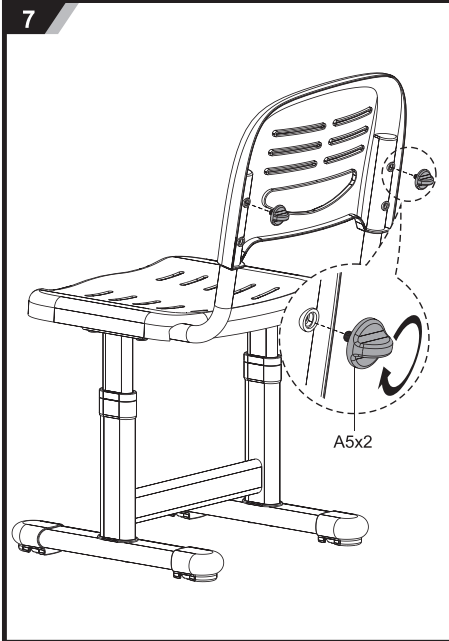
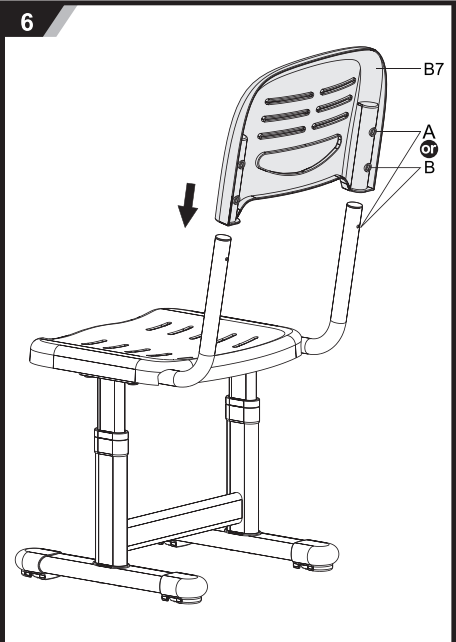
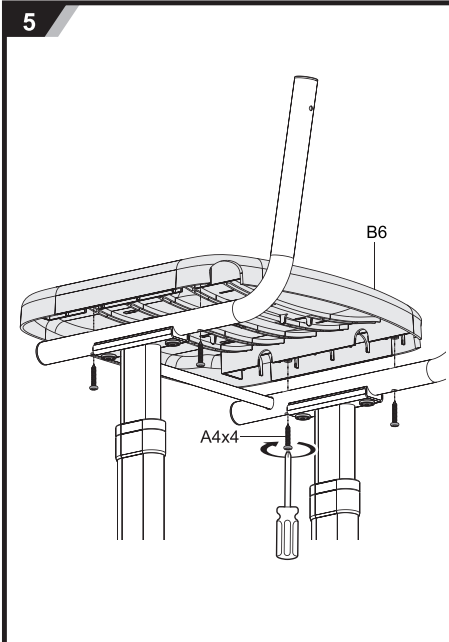

MONTAGGIO DELLA SCRIVANIA

9

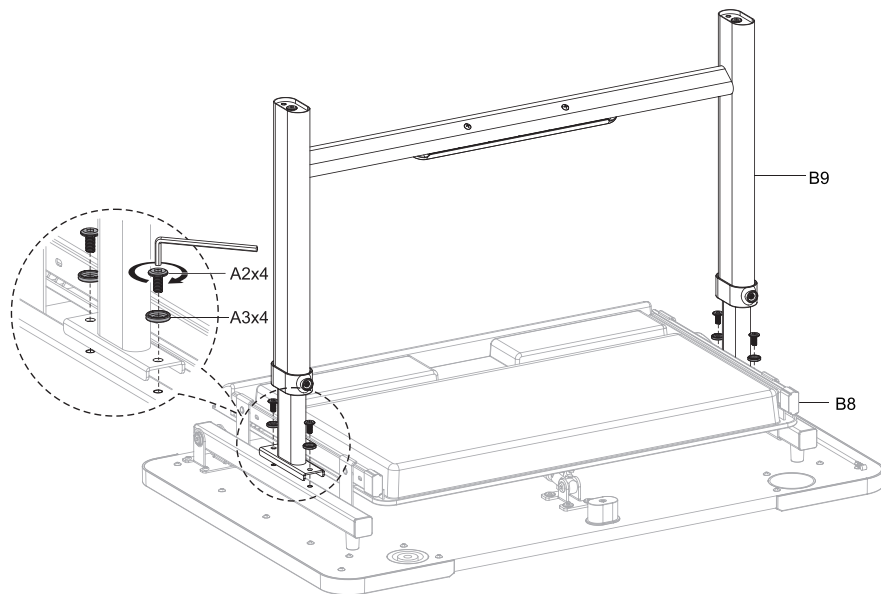

10

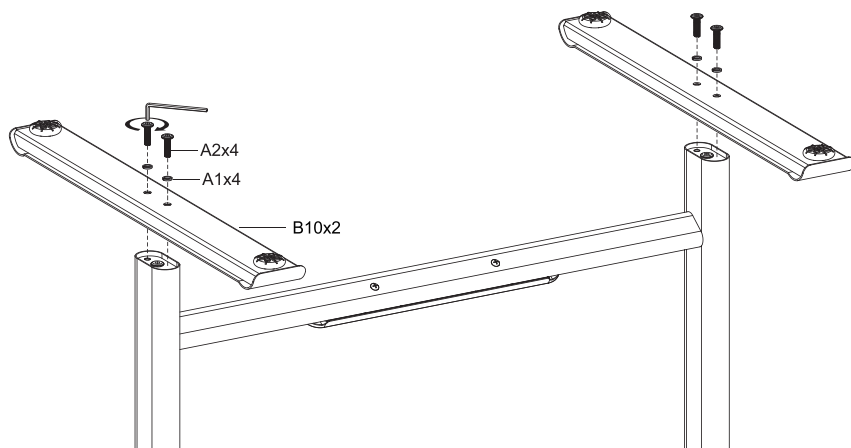

11

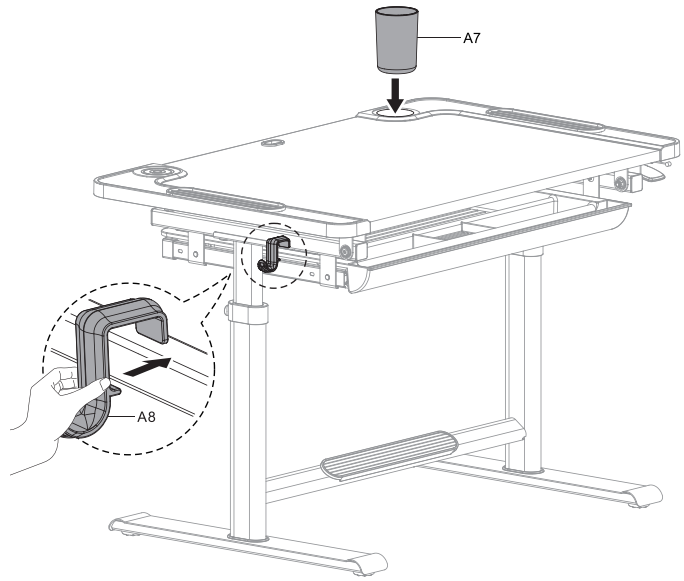

12

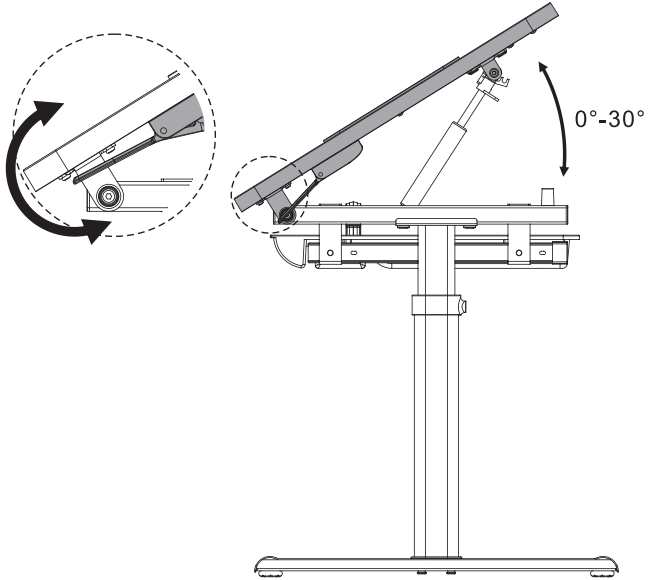

IMPOSTAZIONE DELL'ALTEZZA

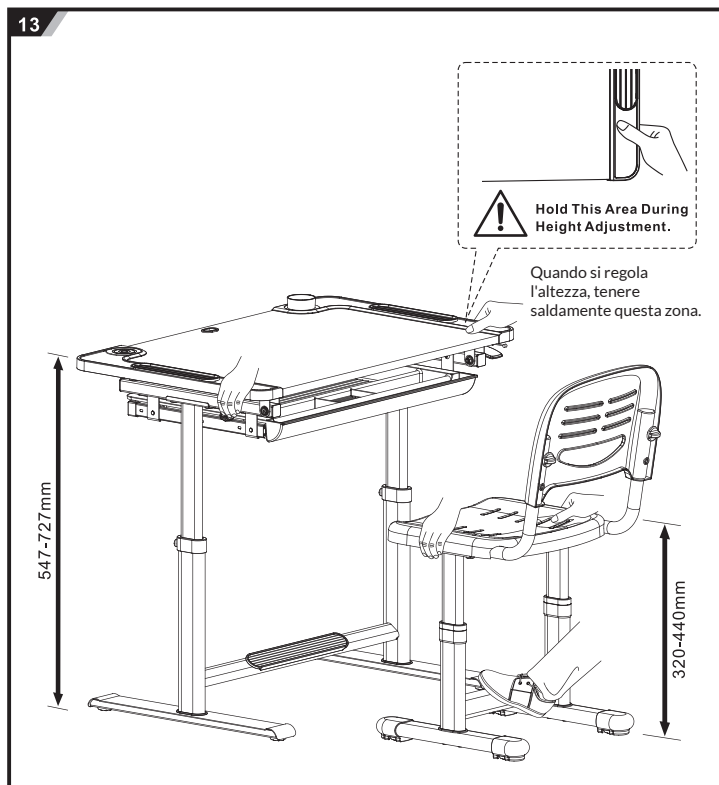

Alzare il piano del tavolo e la sedia

Il piano del tavolo e la sedia possono essere alzati tirandoli verso l'alto. Mettere un piede sulla base del tavolo o della sedia e tirare fino all'altezza desiderata.

Ridurre l'altezza

Impostare l'altezza massima e poi abbassare nella posizione più bassa. Ora è possibile impostare l'altezza desiderata.

Impostazioni consigliate in base alla statura

Queste impostazioni sono raccomandazioni. L'altezza deve essere regolata individualmente.

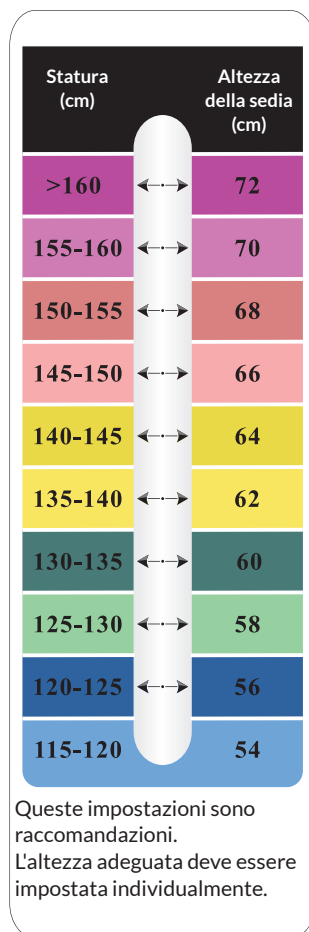

HERSTELLER

Manufacturer | Fabricante | Fabricant | Produttore

Chal-Tec GmbH, Wallstraße 16, 10179 Berlin, Deutschland (Germany).

IMPORTEUR FÜR GROSSBRITANNIEN

**Importer for Great Britain | Importador para Gran Bretaña |
Importateur pour la Grande Bretagne | Importatore per la Gran
Bretagna**

Berlin Brands Group UK Limited
PO Box 42
272 Kensington High Street
London, W8 6ND
United Kingdom

