



blumfeldt

Kindlewood Vertical M

Holzlagerung

Wood Storage

Stockage du bois

Deposito in legno

Almacenamiento de madera



10046345

Sicherheitshinweise

- Für den Aufbau benötigen Sie 2 Personen.
- Der Artikel muss gemäß den Bestimmungen der Bedienungsanleitung zusammengebaut und verwendet werden.
- Dieses Produkt enthält Kleinteile. Bitte stellen Sie sicher, dass diese während des Zusammenbaus von kleinen Kindern ferngehalten werden.
- **Ziehen Sie die Schrauben erst ganz zum Schluss fest an!**

Safety instructions

- For the assembly you need 2 people.
- The product must be assembled and used in accordance with the provisions of the manual.
- This product contains small components, please ensure that they are kept away from small children while assembling.
- **Do not tighten the screws until the very end!**

Consignes de sécurité

- Deux personnes sont nécessaires pour le montage.
- L'article doit être assemblé et utilisé conformément aux dispositions du mode d'emploi.
- Ce produit contient de petites pièces. Veuillez vous assurer qu'elles sont tenues hors de portée des jeunes enfants pendant l'assemblage.
- **Ne serrez pas les vis avant la fin!**

Istruzioni di sicurezza

- Il prodotto deve essere montato e utilizzato in conformità alle disposizioni del manuale.
- Questo prodotto contiene componenti di piccole dimensioni; si prega di assicurarsi che siano tenuti lontani dai bambini durante l'assemblaggio.
- **Non serrare le viti fino alla fine!**

Instrucciones de seguridad

- Se necesitan 2 personas para el montaje.
- El producto debe montarse y utilizarse de acuerdo con las disposiciones del manual.
- Este producto contiene componentes pequeños, asegúrese de mantenerlos fuera del alcance de los niños pequeños durante el montaje.
- **¡No apriete los tornillos hasta el final!**

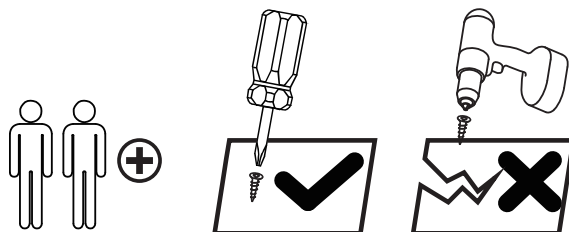

Sehr geehrter Kunde,

wir gratulieren Ihnen zum Erwerb Ihres Produkts. Lesen Sie die folgenden Hinweise sorgfältig durch und befolgen Sie diese, um möglichen Schäden vorzubeugen. Für Schäden, die durch Missachtung der Hinweise und unsachgemäßen Gebrauch entstehen, übernehmen wir keine Haftung. Scannen Sie den folgenden QR-Code, um Zugriff auf die aktuellste Bedienungsanleitung und weitere Informationen rund um das Produkt zu erhalten:

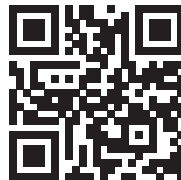
**Dear Customer,**

Congratulations on purchasing this product. Please read the following instructions carefully and follow them to prevent possible damages. We assume no liability for damage caused by disregard of the instructions and improper use. Scan the QR code to get access to the latest user manual and more product information.

Estimado cliente,

Le felicitamos por la adquisición de este producto. Lea atentamente las siguientes instrucciones y sígalas para evitar posibles daños. No asumimos ninguna responsabilidad por los daños causados por el incumplimiento de las instrucciones y el uso inadecuado. Escanee el siguiente código QR para obtener acceso a la última guía del usuario y más información sobre el producto.

Chère cliente, cher client,

Toutes nos félicitations pour l'acquisition de ce nouvel produit. Veuillez lire attentivement et respecter les instructions de ce mode d'emploi afin d'éviter d'éventuels dommages. Nous ne saurions être tenus pour responsables des dommages dus au non-respect des consignes et à la mauvaise utilisation de l'appareil. Scannez le QR-Code pour obtenir la dernière version du mode d'emploi et des informations supplémentaires concernant le produit.

Gentile cliente,

La ringraziamo per aver acquistato il prodotto. La preghiamo di leggere attentamente le seguenti istruzioni per l'uso e di seguirle per evitare possibili danni. Non ci assumiamo alcuna responsabilità per danni scaturiti da una mancata osservazione delle avvertenze di sicurezza e da un uso improprio del dispositivo. Scansionare il codice QR seguente, per accedere al manuale d'uso più attuale e per ricevere informazioni sul prodotto.

Hersteller | Manufacturer | Fabricante | Fabricant | Produttore

Chal-Tec GmbH, Wallstraße 16, 10179 Berlin, Deutschland (Germany).





Importer for Great Britain |



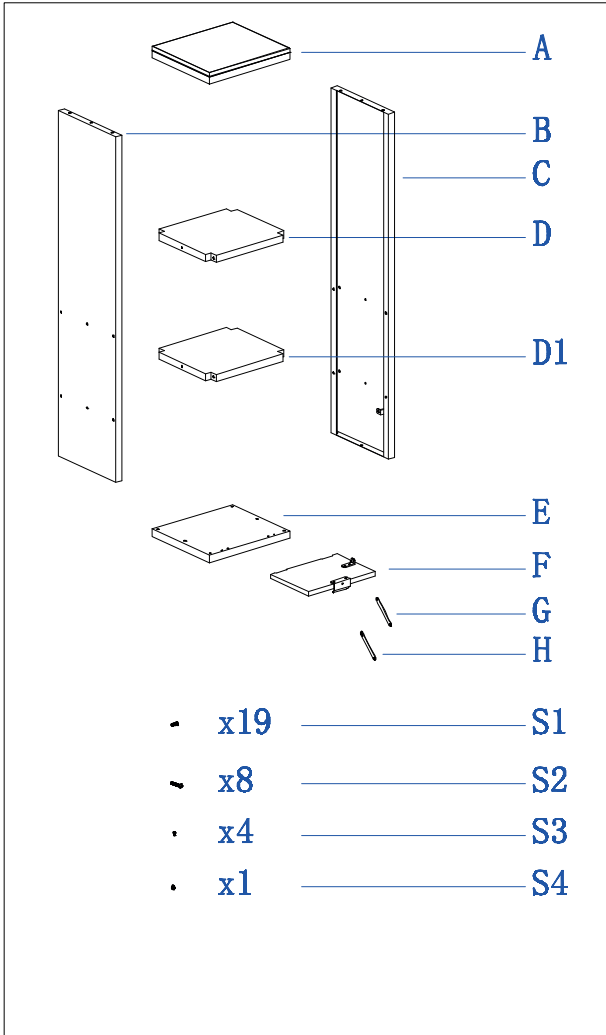

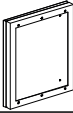
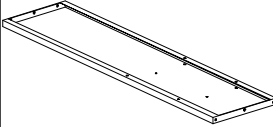
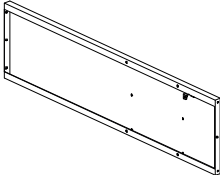

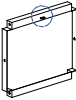
Berlin Brands Group UK Limited
PO Box 42
272 Kensington High Street
London, W8 6ND
United Kingdom

LIEFERUMFANG

Scope of delivery | Volumen de suministro | Contenu de la livraison | Dotazione di fornitura



A	1	
B	1	
C	1	
D	1	
D1	1	
E	1	
F	1	

G	1	
H	1	
S1 (M6*12)	19	
S2 (M6*40)	8	
S3 (M6)	4	
S3 (M6)	1	

ZUSAMMENBAU

Assembly | Ensamblaje | Assemblée | Assemblaggio

