

# WALD CHEF

Spülenschrank  
Sink cabinet  
Armario para lavabo  
Meuble évier  
Mobile lavello

10048522



COOKINGCO  
OKINGCOO  
KINGCOOKIN  
INGCOOKING  
COOKINGCO  
OOKINGCOO  
KINGCOOKIN  
INGCOOKING

## KLARSTEIN

[www.klarstein.eu](http://www.klarstein.eu)

Rev. 01/26



**Sehr geehrter Kunde,**

wir gratulieren Ihnen zum Erwerb Ihres Produkts. Lesen Sie die folgenden Hinweise sorgfältig durch und befolgen Sie diese, um möglichen Schäden vorzubeugen. Für Schäden, die durch Missachtung der Hinweise und unsachgemäßen Gebrauch entstehen, übernehmen wir keine Haftung. Scannen Sie den folgenden QR-Code, um Zugriff auf die aktuellste Bedienungsanleitung und weitere Informationen rund um das Produkt zu erhalten:

**Dear Customer,**

Congratulations on purchasing this product. Please read the following instructions carefully and follow them to prevent possible damages. We assume no liability for damage caused by disregard of the instructions and improper use. Scan the QR code to get access to the latest user manual and more product information.

**Estimado cliente,**

Le felicitamos por la adquisición de este producto. Lea atentamente las siguientes instrucciones y sígalas para evitar posibles daños. No asumimos ninguna responsabilidad por los daños causados por el incumplimiento de las instrucciones y el uso inadecuado. Escanee el siguiente código QR para obtener acceso a la última guía del usuario y más información sobre el producto.

**Chère cliente, cher client,**

Toutes nos félicitations pour l'acquisition de ce nouvel produit. Veuillez lire attentivement et respecter les instructions de ce mode d'emploi afin d'éviter d'éventuels dommages. Nous ne saurions être tenus pour responsables des dommages dus au non-respect des consignes et à la mauvaise utilisation de l'appareil. Scannez le QR-Code pour obtenir la dernière version du mode d'emploi et des informations supplémentaires concernant le produit.

**Gentile cliente,**

La ringraziamo per aver acquistato il prodotto. La preghiamo di leggere attentamente le seguenti istruzioni per l'uso e di seguirle per evitare possibili danni. Non ci assumiamo alcuna responsabilità per danni scaturiti da una mancata osservazione delle avvertenze di sicurezza e da un uso improprio del dispositivo. Scansionare il codice QR seguente, per accedere al manuale d'uso più attuale e per ricevere informazioni sul prodotto.

---

**HERSTELLER**

---

**Manufacturer | Fabricante | Fabricant | Produttore**

Chal-Tec GmbH, Mühlenstraße 25, 10243 Berlin, Deutschland (Germany).

---

## SICHERHEITSHINWEISE (DE)

---

- Dieses Möbelstück ist für den Einsatz im Freien gestaltet.
- Identifizieren Sie alle Teile und alles Zubehör. Werfen Sie die Verpackung erst dann weg, wenn Sie sich vergewissert haben, dass Sie alle benötigten Teile und Zubehörelemente haben. Das Zubehörpaket kann Ersatzteile enthalten.



### WARNUNG

Dieser Artikel enthält Kleinteile, die von Kindern und Haustieren verschluckt werden können. Halten Sie Kinder und Haustiere während des Zusammenbaus fern. Um Erstickungsgefahr zu vermeiden, bewahren Sie Plastiktüten stets außerhalb der Reichweite von Kindern und Haustieren auf.

- Wir empfehlen Ihnen, das Gerät auf einem Teppichboden aufzubauen, um Kratzer zu vermeiden.
- Stellen Sie bei der Verwendung von Elektrowerkzeugen ein niedriges Drehmoment ein, um Schäden zu vermeiden.
- Für eine einfache Montage sind möglicherweise zwei Personen erforderlich.



### VORSICHT

Verletzungsgefahr! Die Kanten des Bedienfeldes sind scharf. Mangelnde Vorsicht kann zu Verletzungen oder Schnittwunden führen.

---

## SAFETY INSTRUCTIONS (EN)

---

- This furniture is designed for outdoor use .
- Identify all the parts and hardware. Do not discard of the packaging until you have checked that you have all the parts and hardware required. Hardware package may have spare parts.



### WARNING

This item contains small parts which can be swallowed by children and pets. Keep children and pets away during assembly. To avoid danger of suffocation, always keep plastic bags away from children and pets.

- We recommend that you assemble this unit on a carpeted floor to avoid scratches.
- If using power tools, set the tool to low torque to avoid damage.
- May require 2 people for ease of assembly



### CAUTION

Risk of injury! Panel edges are sharp. Failure to use caution could result in injury or cuts.

---

## INDICACIONES DE SEGURIDAD (ES)

---

- Este mueble está diseñado para su uso en exteriores.
- Identifique todas las piezas y herrajes. No deseche el embalaje hasta que haya comprobado que tiene todas las piezas y los accesorios necesarios. El paquete de herrajes puede contener piezas de repuesto.



### ADVERTENCIA

Este artículo contiene piezas pequeñas que pueden ser ingeridas por niños y mascotas. Mantenga alejados a los niños y las mascotas durante el montaje. Para evitar el peligro de asfixia, mantenga siempre las bolsas de plástico fuera del alcance de los

niños y las mascotas.

- Le recomendamos que monte esta unidad sobre una superficie alfombrada para evitar arañazos.
- Si utiliza herramientas eléctricas, ajuste la herramienta a un par bajo para evitar daños.
- Puede requerir 2 personas para facilitar el montaje.



### PRECAUCIÓN

¡Peligro de lesiones! Los bordes del panel están afilados. La falta de precaución puede provocar lesiones o cortes.

---

## CONSIGNES DE SÉCURITÉ (FR)

---

- Ce mobilier est conçu pour une utilisation en extérieur.
- Identifiez toutes les pièces et le matériel. Ne jetez pas l'emballage avant d'avoir vérifié que vous disposez de toutes les pièces et de tout le matériel nécessaires. L'emballage du matériel peut contenir des pièces de rechange.



### MISE EN GARDE

Cet article contient de petites pièces pouvant être avalées par les enfants et les animaux domestiques. Tenir les enfants et les animaux à l'écart pendant le montage. Pour éviter tout risque de suffocation, gardez les sacs en plastique hors de portée des

enfants et des animaux domestiques.

- Nous vous recommandons d'assembler l'appareil sur un sol recouvert de moquette afin d'éviter les rayures.
- Si vous utilisez un outil électrique, réglez un couple faible afin d'éviter tout dommage.
- L'assemblage peut nécessiter l'intervention de deux personnes



### ATTENTION

Risque de blessure ! Les bords des panneaux sont tranchants. Le non-respect des précautions peut entraîner des blessures ou des coupures.

---

## AVVERTENZE DI SICUREZZA (IT)

---

- Questo mobile è progettato per l'uso all'aperto.
- Identificare tutti i componenti e gli accessori. Non smaltire l'imballaggio prima di aver verificato di avere tutti i componenti e gli accessori necessari. La confezione degli accessori può contenere parti di ricambio.



### AVVERTENZA

Questo articolo contiene piccole parti che possono essere ingerite da bambini e animali domestici. Tenere lontani i bambini e gli animali domestici durante il montaggio. Per evitare il rischio di soffocamento, tenere sempre i sacchetti di plastica lontano dai bambini e dagli animali domestici.

- Si consiglia di montare l'unità su un pavimento in moquette per evitare graffi.
- Se si utilizzano attrezzi elettrici, impostare l'attrezzo su una coppia bassa per evitare danni.
- Per facilitare il montaggio possono essere necessarie 2 persone.



### ATTENZIONE

Rischio di lesioni! I bordi del pannello sono taglienti. La mancata osservanza di questa precauzione può provocare lesioni o tagli.

---

## LIEFERUMFANG (DE)

---

<b>Nr.</b>	<b>Name</b>	<b>Menge</b>
1	Messer-Magnet	1
2	Hintere Aluminiumaufhängung	1
3	Gewürzregal	1
4	Korb an oberer Platte	1
5	Aufhänger	3
6	Arbeitsplatte + Spüle	1
7	Hintere obere Platte	1
8	Vordere obere Platte	1
9	Ablaufschlauch	1
10	Rückseite	1
11	Hintere Verbindung für Arbeitsplatte	4
12	Adjustable feet	4
13	Stützhalterung	1
14	linke Platte	1
15	rechte Platte	1
16	Mülleimer	1
17	Mülleimer-Halter	1
18	Boden des Mülleimers	1
19	Mülleimer linke Halterung	1
20	Mülleimer rechte Halterung	1
21	Mittlere Platte	1
22	Schubladen-/Türmagnet	1
23	Bodenplatte der Schublade	1
24	Untere Platte	1
25	Tür	1
26	Schubladentürverkleidung	1
27	Sockel vorne/hinten	2

---

## SCOPE OF DELIVERY (EN)

---

No.	Name	Quantity
1	Knife Magnet	1
2	Rear Aluminum Hanger	1
3	Spice Rack	1
4	Top Panel Basket	1
5	Hanger	3
6	Countertop+sink	1
7	Rear top panel	1
8	Front top panel	1
9	Drain pipe	1
10	Rear panel	1
11	Rear linkage for countertop	4
12	Adjustable feet	4
13	support bracket	1
14	left panel	1
15	right panel	1
16	Trash bin	1
17	Trash bin Holder	1
18	Trash bin bottom	1
19	Trash bin left bracket	1
20	Trash bin right bracket	1
21	Middle panel	1
22	Drawer/Door magnet	1
23	Drawer bottom panel	1
24	Bottom panel	1
25	Door	1
26	Drawer door panel	1
27	Front/back plinth	2

---

## VOLUMEN DE SUMINISTRO (ES)

---

Núm.	Nombre	Cantidad
1	Imán para cuchillos	1
2	Gancho trasero de aluminio	1
3	Estante para especias	1
4	Cesta del panel superior	1
5	Gancho	3
6	Encimera + fregadero	1
7	Panel superior trasero	1
8	Panel superior frontal	1
9	Tubo de desagüe	1
10	Panel trasero	1
11	Enganche trasero para encimera	4
12	Patas ajustables	4
13	Soporte de sujeción	1
14	Panel izquierdo	1
15	Panel derecho	1
16	Cubo de basura	1
17	Soporte para cubo de basura	1
18	Fondo del cubo de basura	1
19	Soporte izquierdo del cubo de basura	1
20	Soporte derecho del cubo de basura	1
21	Panel central	1
22	Imán para cajón/puerta	1
23	Panel inferior del cajón	1
24	Panel inferior	1
25	Puerta	1
26	Panel de la puerta del cajón	1
27	Zócalo delantero/trasero	2

---

## CONTENU DE LA LIVRAISON (FR)

---

N°	Désignation	Quantité
1	Aimant pour couteau	1
2	Support arrière en aluminium	1
3	Porte-épices	1
4	Panier du panneau supérieur	1
5	Support	3
6	Plan de travail + évier	1
7	Panneau supérieur arrière	1
8	Panneau avant supérieur	1
9	tuyau d'évacuation	1
10	Panneau arrière	1
11	Raccordement arrière pour le comptoir	4
12	Pieds réglables	4
13	Support de soutien	1
14	panneau gauche	1
15	panneau de droite	1
16	Poubelle	1
17	Porte-poubelle	1
18	Fond de poubelle	1
19	Support gauche de la poubelle	1
20	Support de droite de la poubelle	1
21	Panneau central	1
22	Aimant pour tiroir et porte	1
23	Panneau inférieur du tiroir	1
24	Panneau inférieur	1
25	Porte	1
26	Panneau de la porte du tiroir	1
27	Socle avant/arrière	2

---



## VOLUME DI CONSEGNA (IT)

---

<b>N.</b>	<b>Nome</b>	<b>Quantità</b>
1	Magnete per coltelli	1
2	Gancio posteriore in alluminio	1
3	Portaspezie	1
4	Cestello del pannello superiore	1
5	Gancio	3
6	Piano di lavoro+lavello	1
7	Pannello superiore posteriore	1
8	Pannello superiore anteriore	1
9	Tube di scarico	1
10	Pannello posteriore	1
11	Collegamento posteriore per il piano di lavoro	4
12	Piedi d'appoggio regolabili	4
13	Staffa di supporto	1
14	Pannello sinistro	1
15	Pannello destro	1
16	Cestino dei rifiuti	1
17	Supporto del cestino dei rifiuti	1
18	Fondo del cestino dei rifiuti	1
19	Supporto sinistro del cestino dei rifiuti	1
20	Supporto destro del cestino dei rifiuti	1
21	Pannello centrale	1
22	Magnete per cassetto/sportello	1
23	Pannello inferiore del cassetto	1
24	Pannello inferiore	1
25	Sportello	1
26	Pannello dell'anta del cassetto	1
27	Zoccolo anteriore/posteriore	2

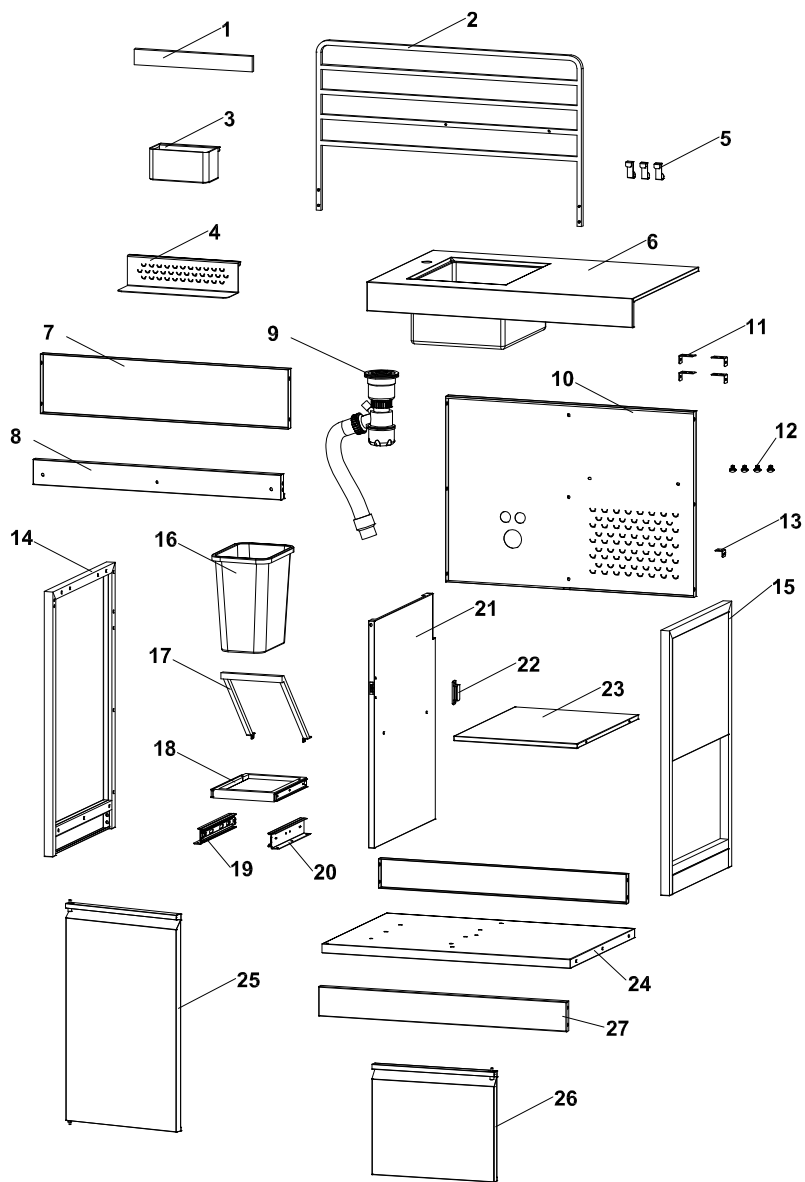
**EXPLOSIONSDIAGRAMM/ EXPLODED VIEW/ DIAGRAMA DE EXPLOSIÓN/ SCHÉMA ÉCLATÉ/ DIAGRAMMA ESPLOSO**

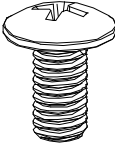
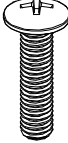
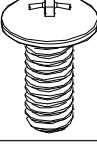
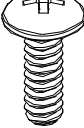

	Beschreibung/Specification/ Especificación/ Spécifications/ Specifiche	Anzahl/ Quantity/ Cantidad/ Quantité/ Quantità
	M6x12	55 (einschließlich 2 Ersatzschrauben)/ 55 (including 2 spare screws)/ 55 (incluidos 2 tornillos de repuesto)/ 55 (y compris 2 vis de rechange)/ 55 (comprese 2 viti di ricambio)
	M6x25	4
	M5x12	12
	M4x12	6
	Adjustable feet	4

**Benötigte Werkzeuge/ Tools needed/ Herramientas necesarias/  
Outils nécessaires/ Attrezzi necessari**

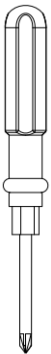

Nicht enthalten/not included/ no incluido/  
non inclus/ non inclusi

---

## ZUSAMMENBAU/ ASSEMBLY/ MONTAJE/ ASSEMBLAGE/ MONTAGGIO

---

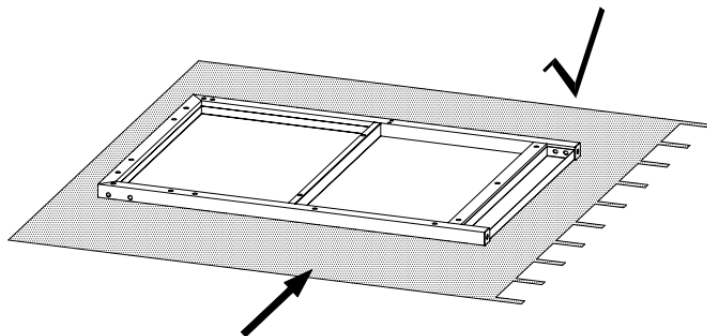

Oberflächen vor der Montage abdecken, um Schäden zu vermeiden.  
Pre-pad surfaces before assembly to prevent damage.  
Cubra las superficies antes del montaje para evitar daños.  
Préparez les surfaces avant l'assemblage pour éviter de les endommager.  
Prima dell'assemblaggio, le superfici devono essere dotate di un fondo morbido per evitare danni.

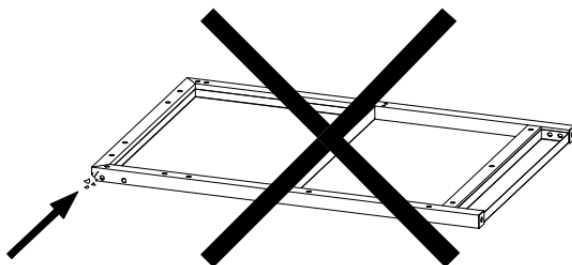

1

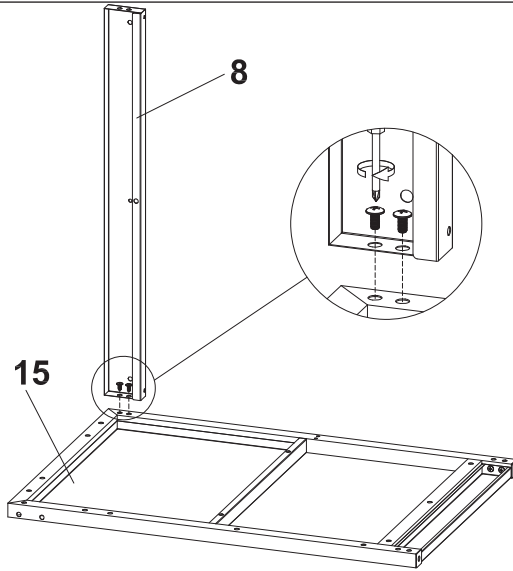

 M6x12 2PCS

2

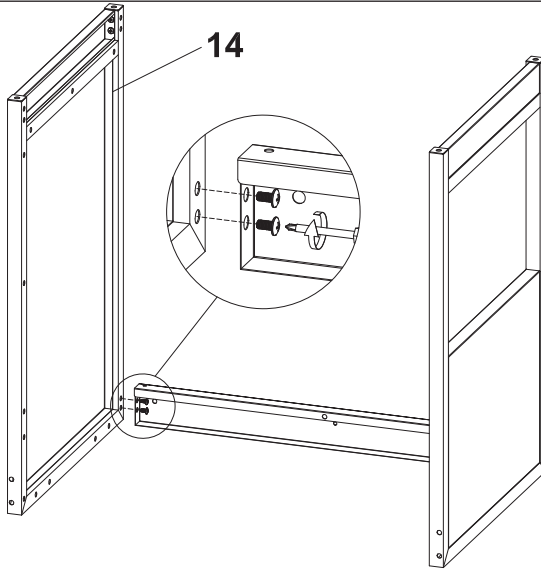

 M6x12 2PCS

3

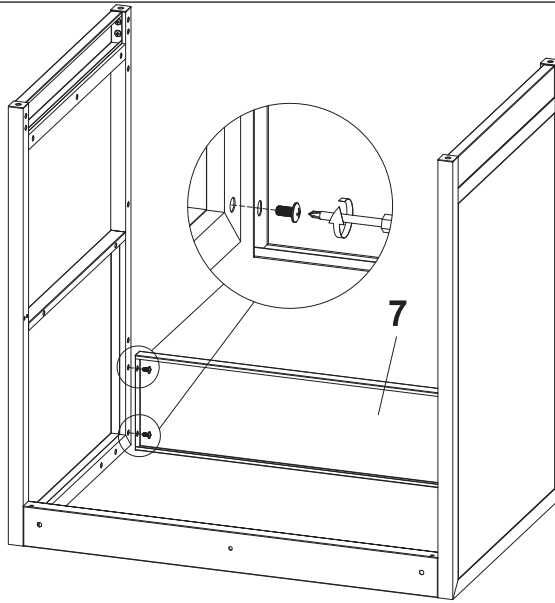

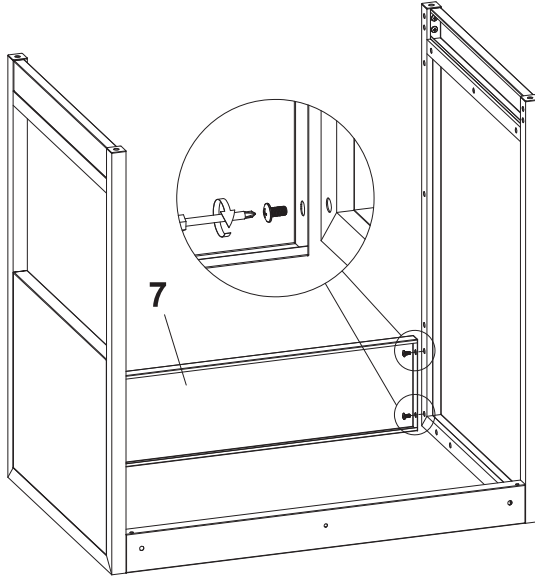

 M6x12 2PCS

4

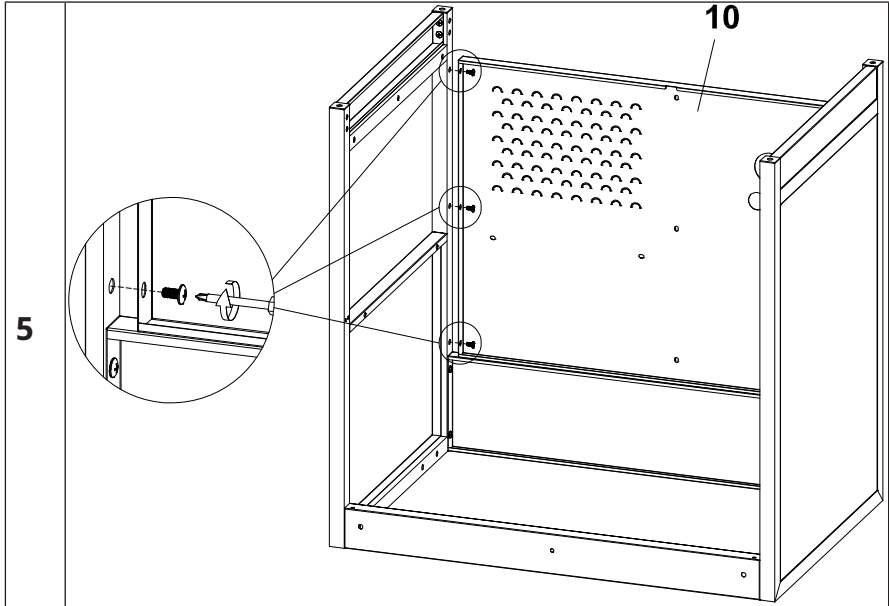

 M6x12 2PCS



 M6x12 3PCS

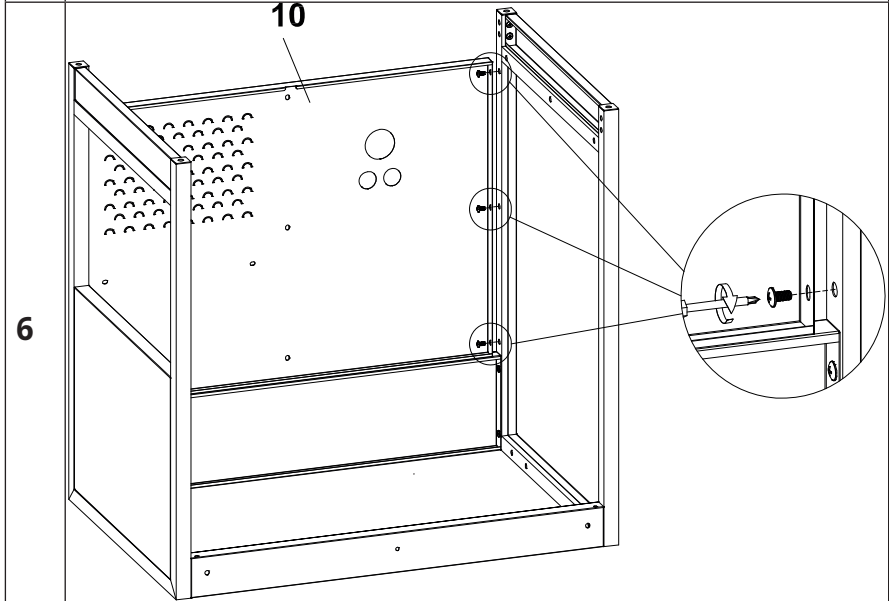

 M6x12 3PCS

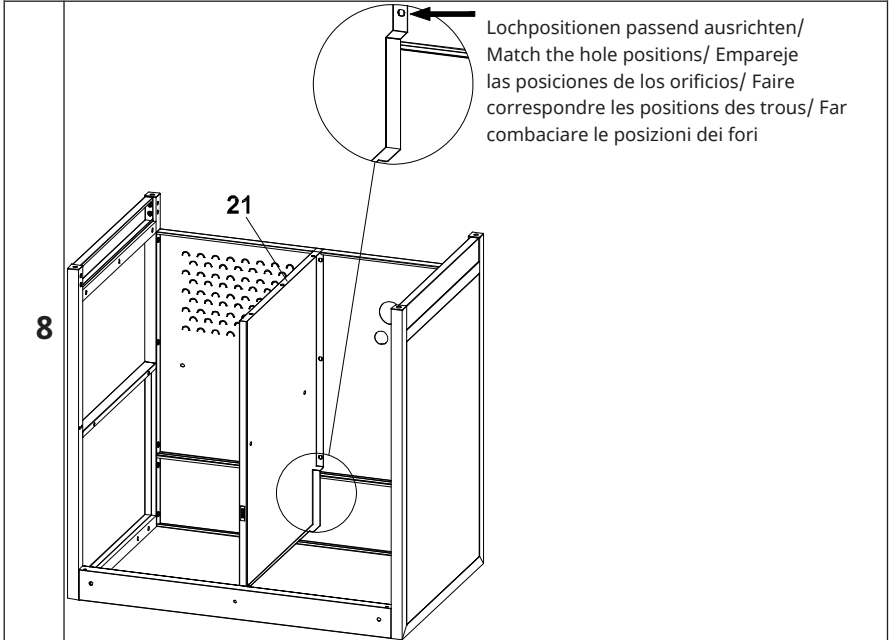
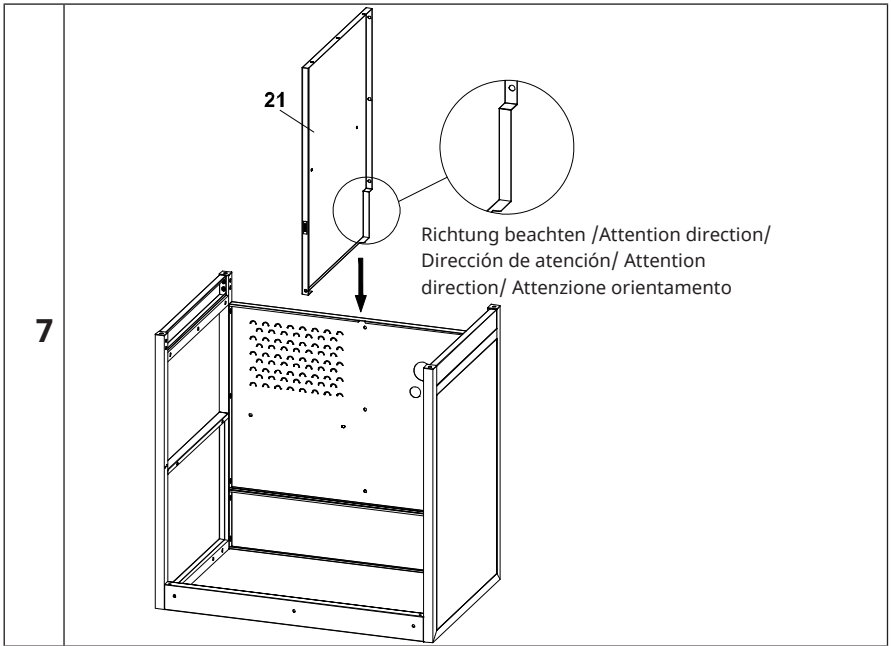

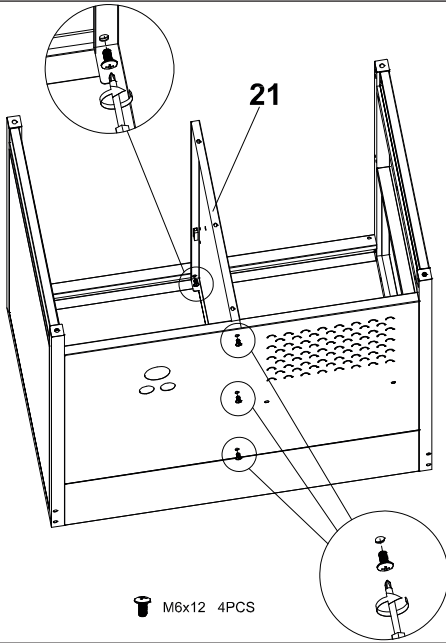

9

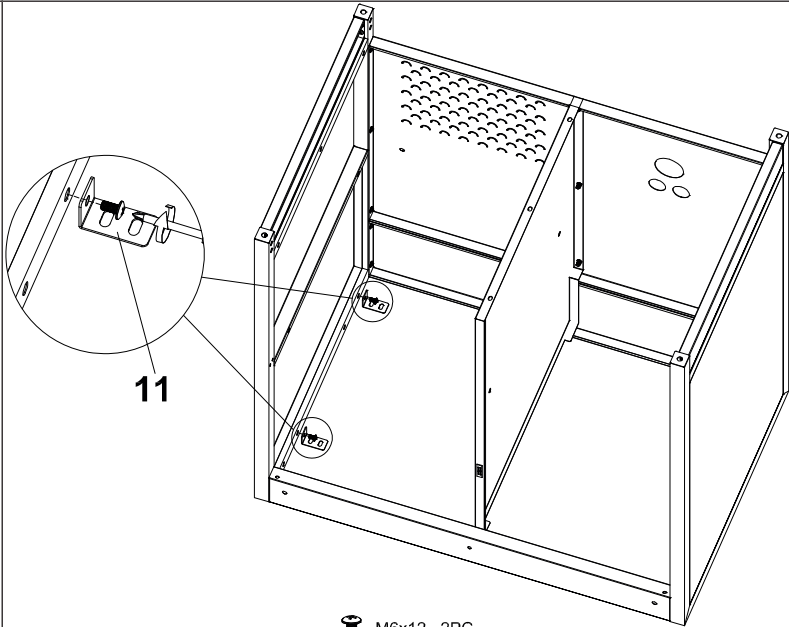

 M6x12 4PCS

10



 M6x12 2PC

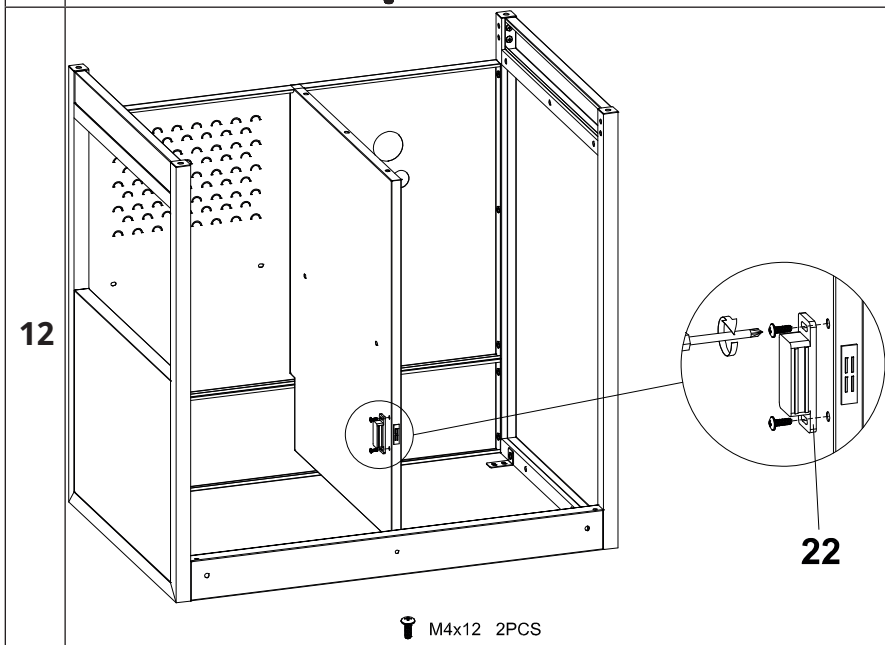
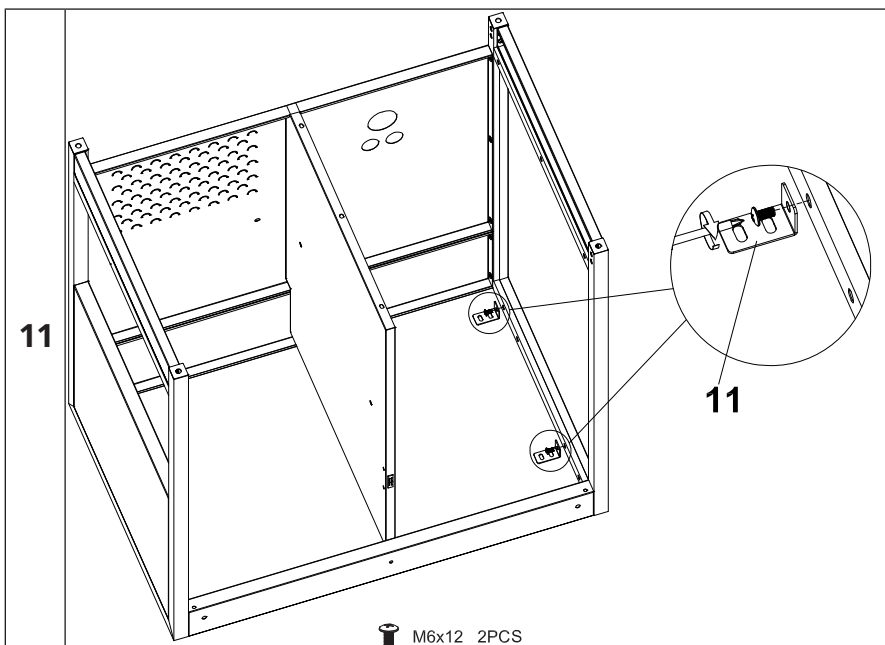

13

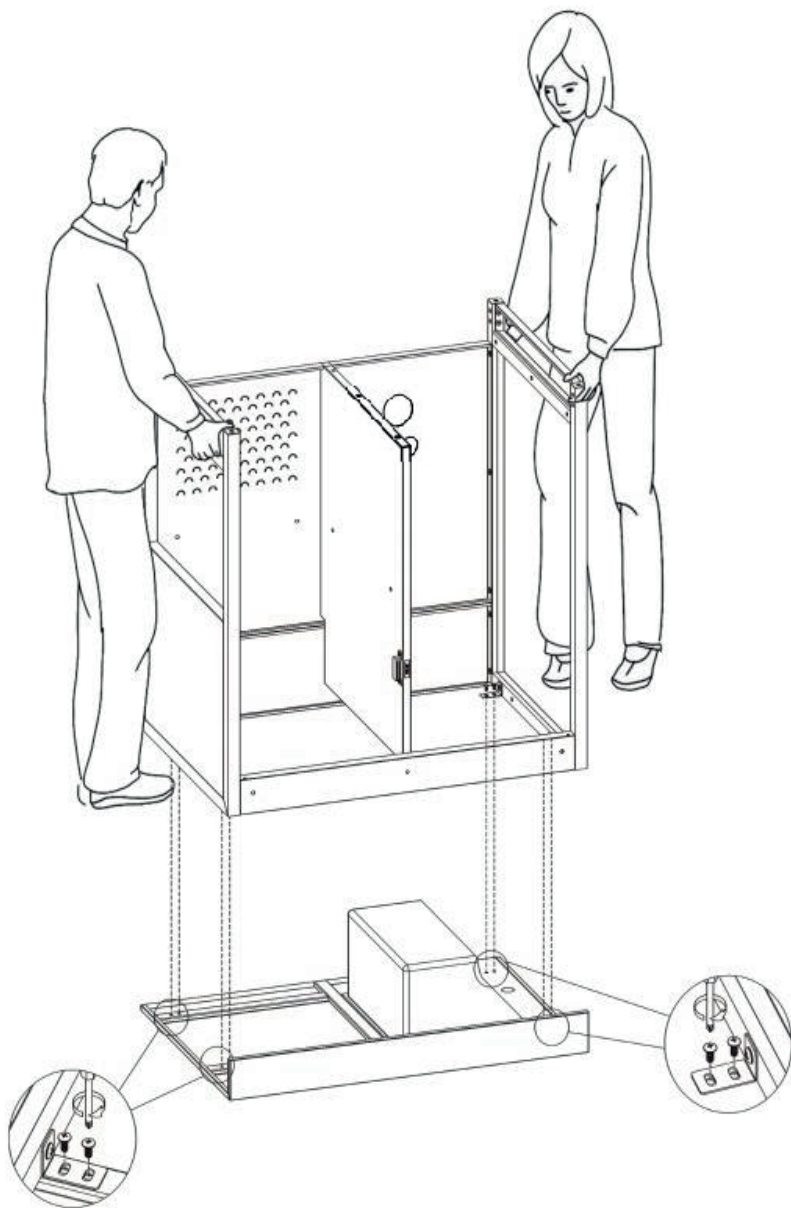

🔩 M5x12 8 PCS

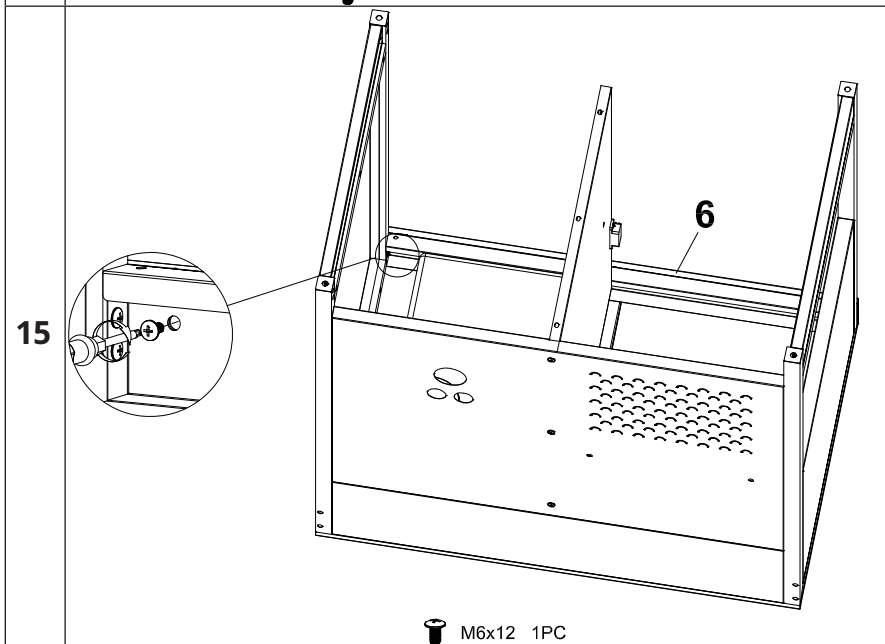
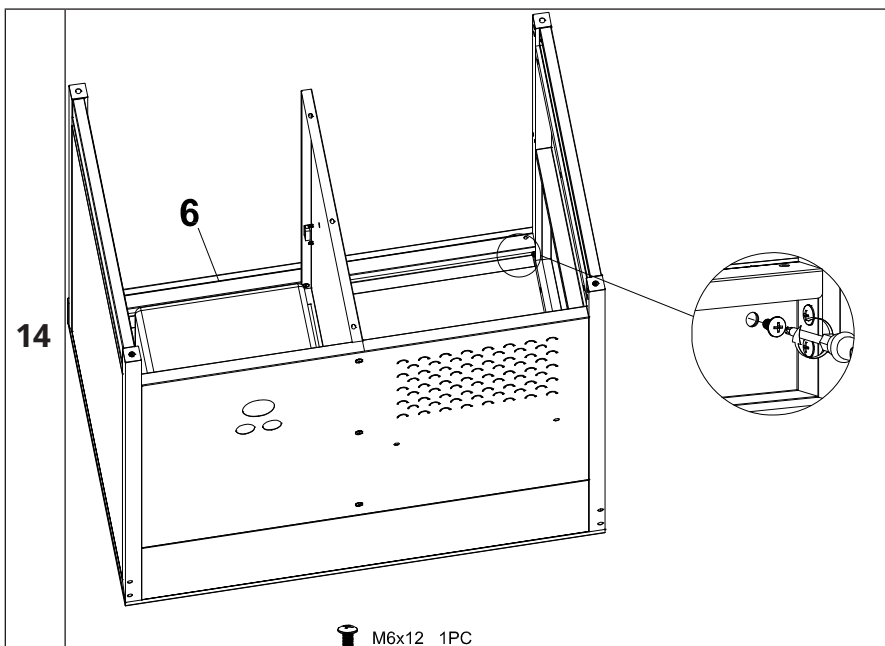

16

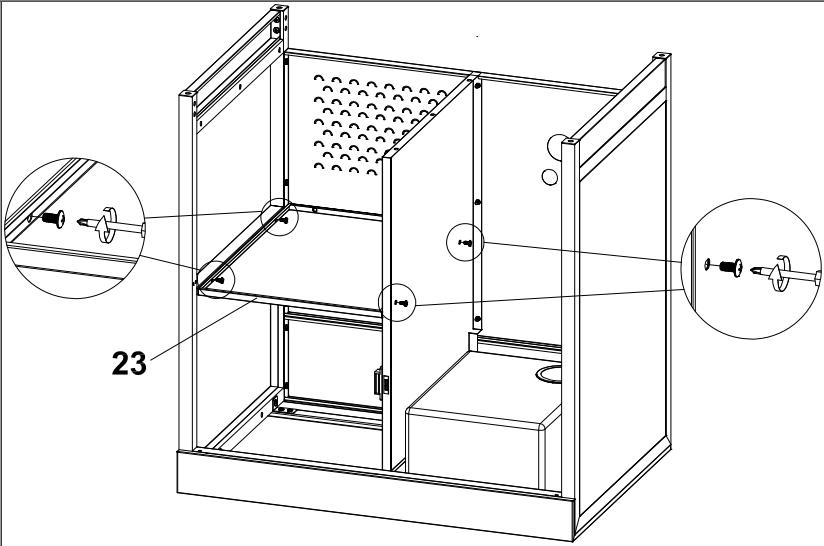

M6x12 4PCS

17

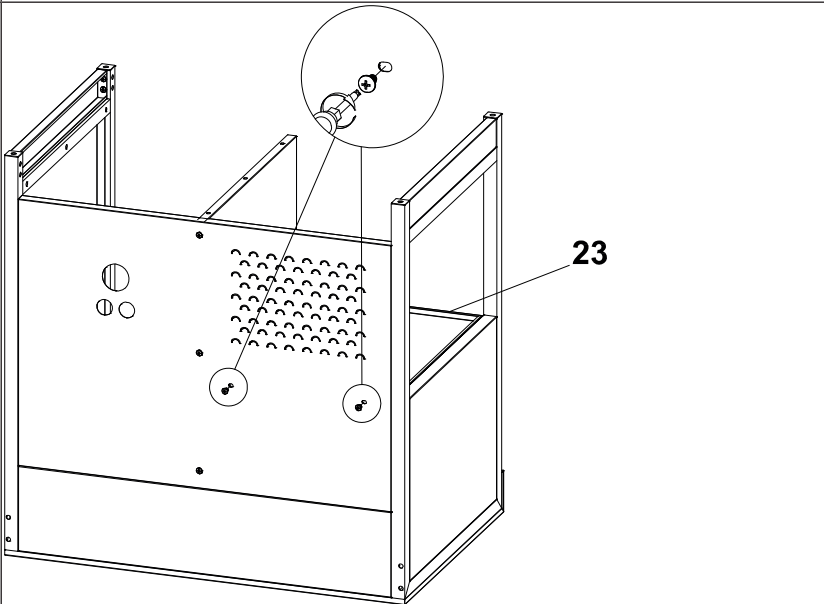

M6x12 2PCS

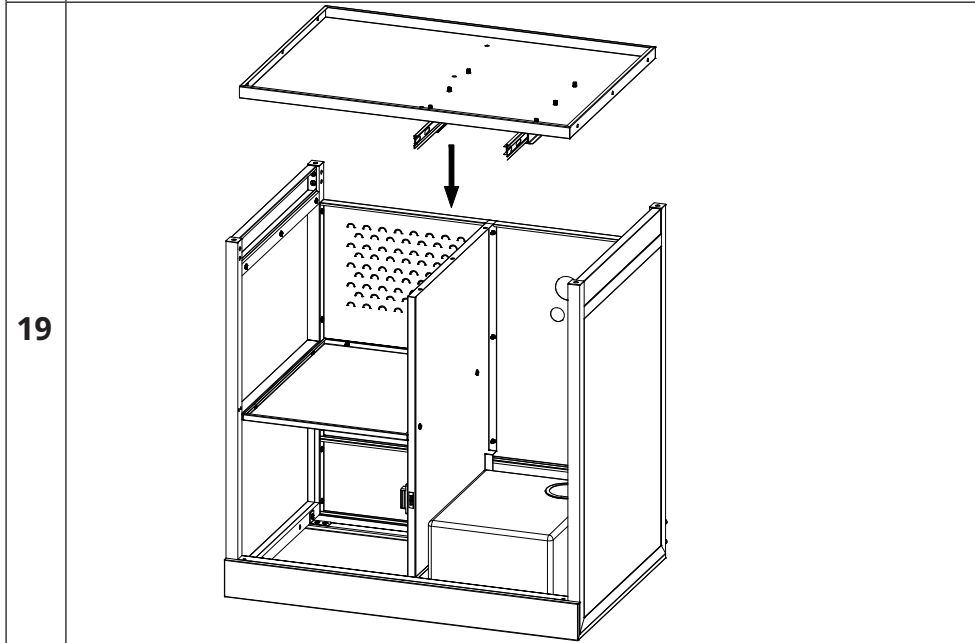
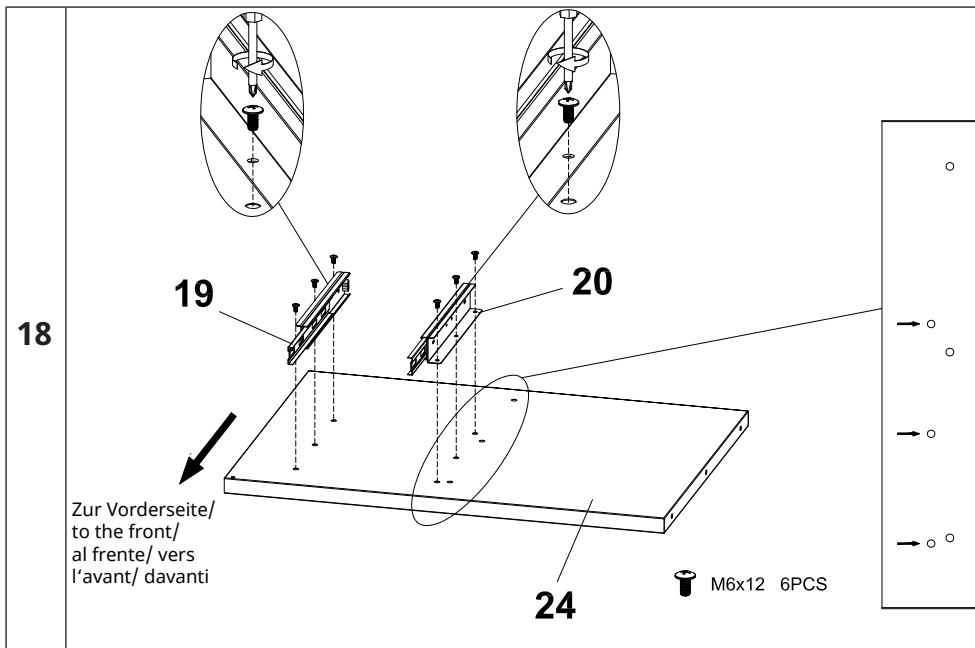

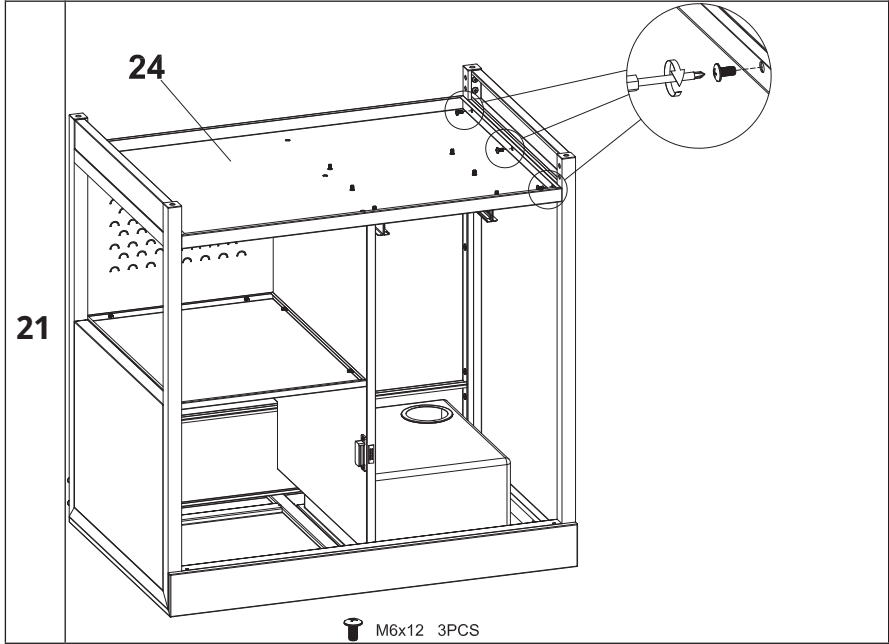
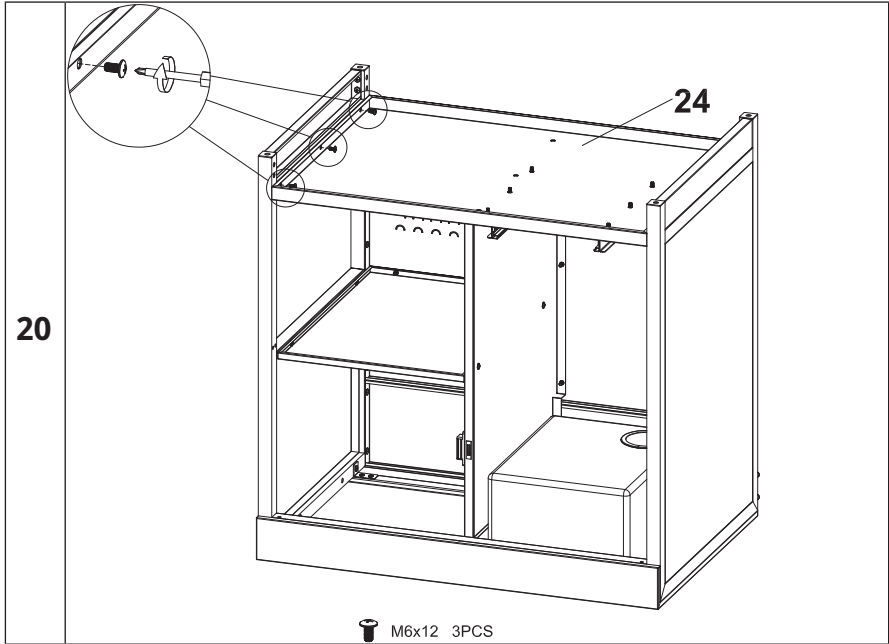

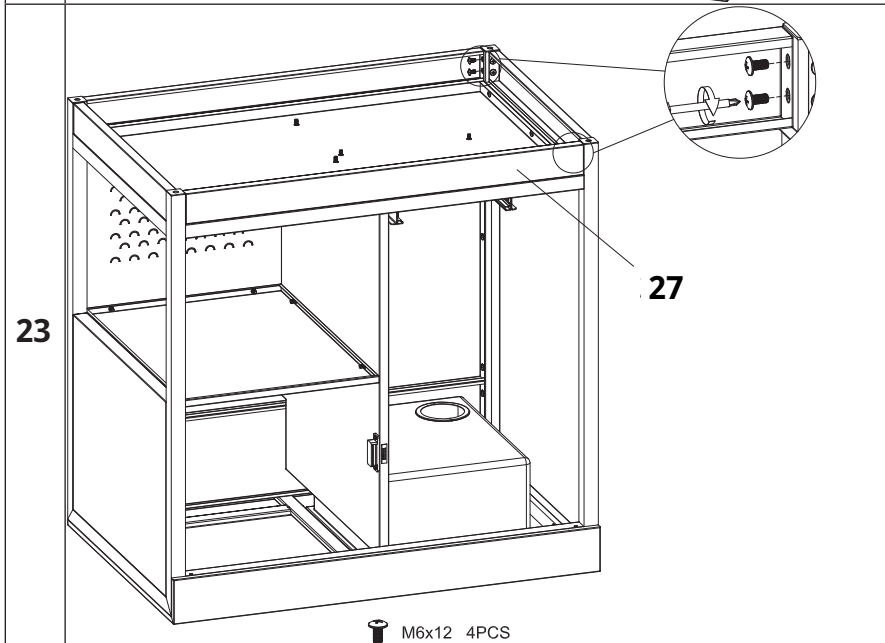
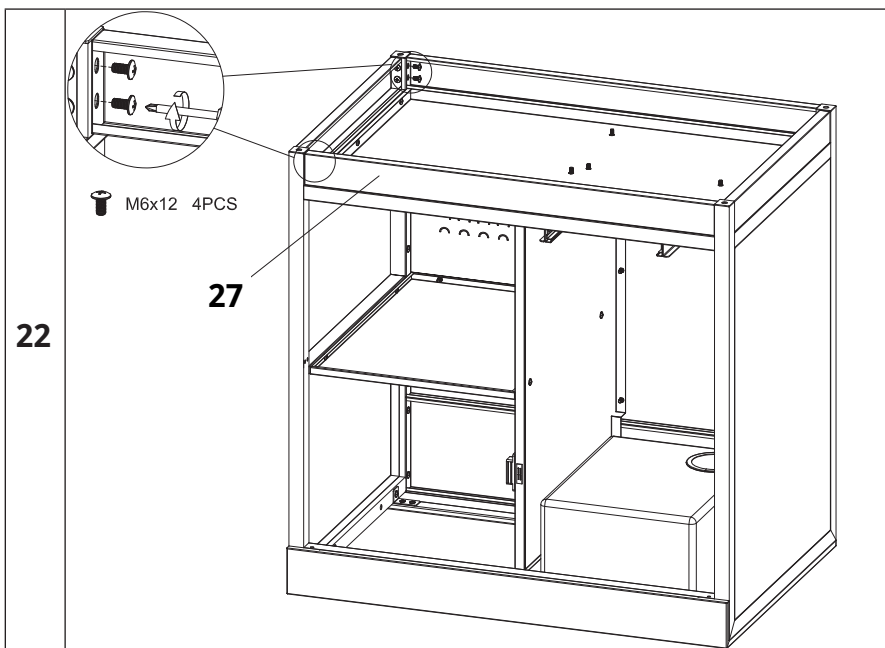

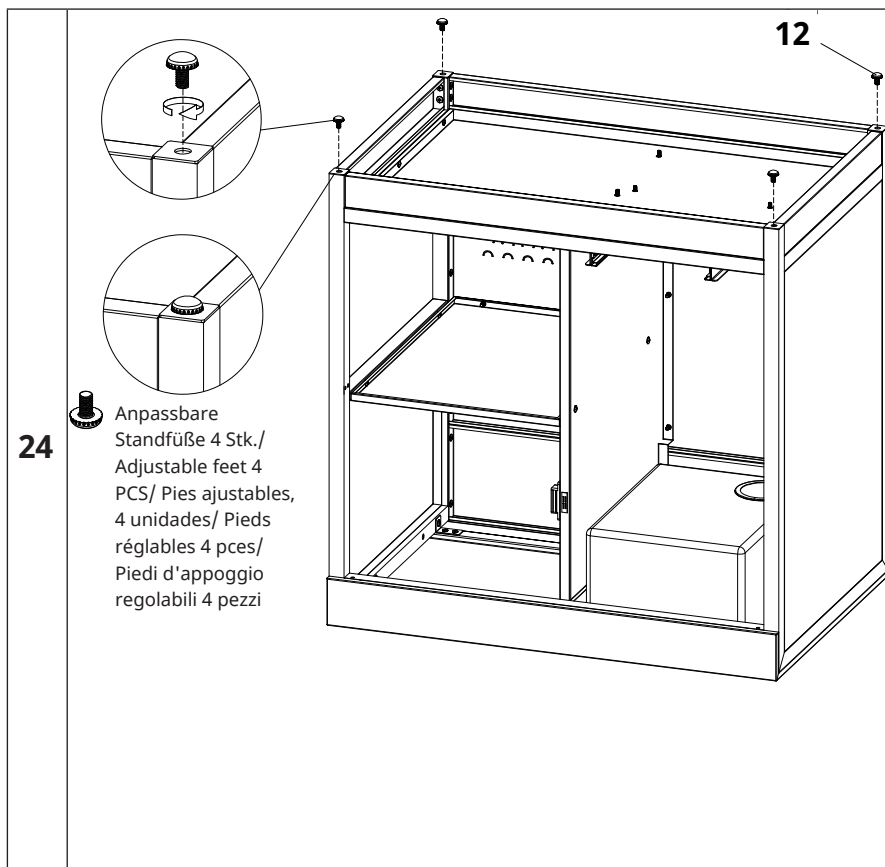

**24**



Anpassbare  
Standfüße 4 Stk./  
Adjustable feet 4  
PCS/ Pies ajustables,  
4 unidades/ Pieds  
réglables 4 pcs/  
Piedi d'appoggio  
regolabili 4 pezzi

**12**

**Produkt umdrehen/ Reverse product/ Invierta el producto/ Inverser le produit/ Rovesciare l'unità**

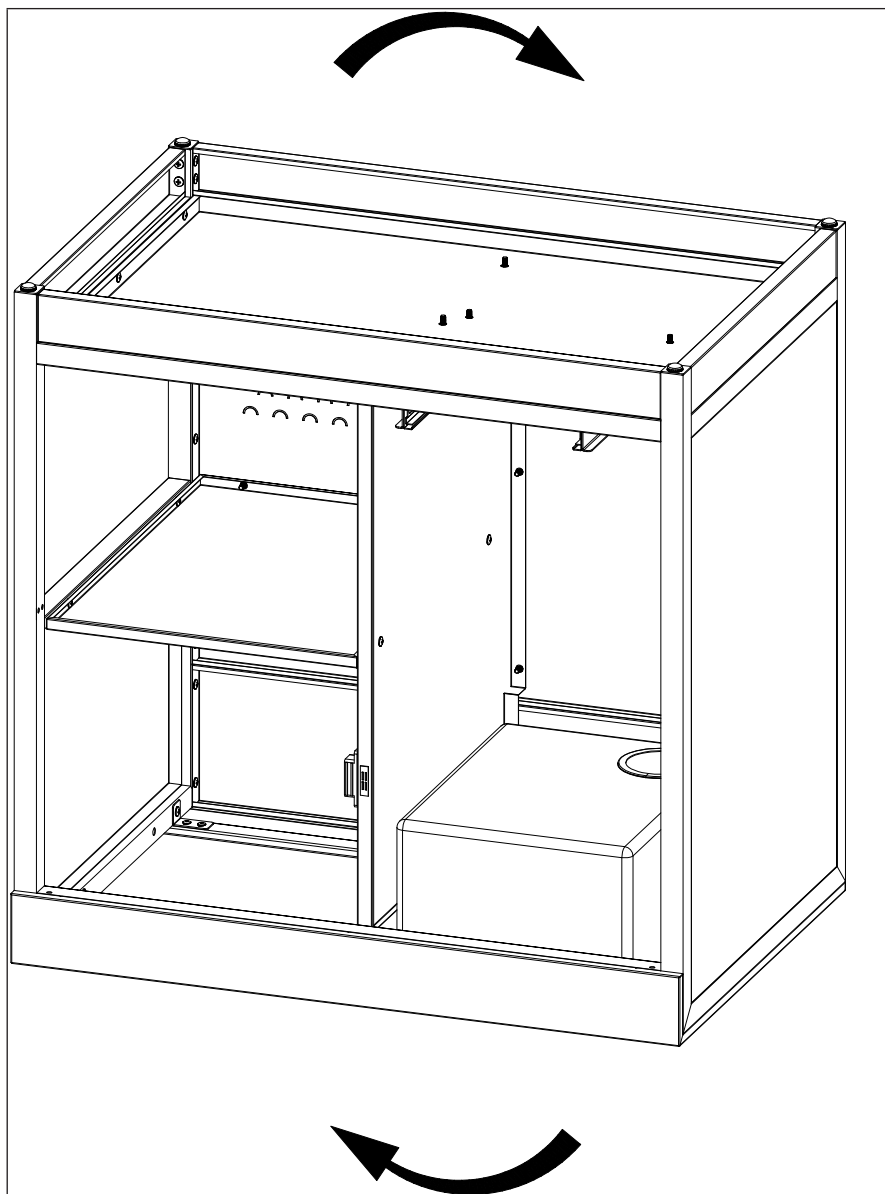

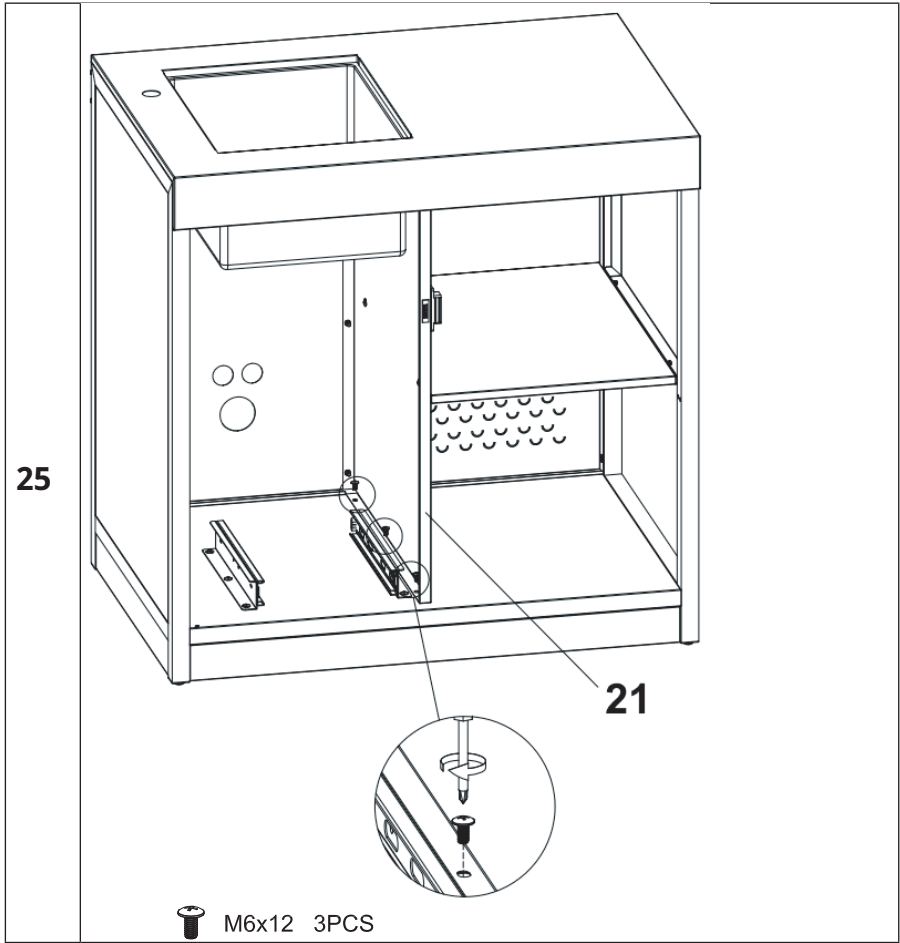

26

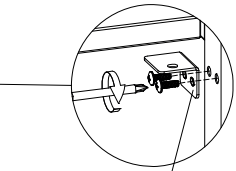
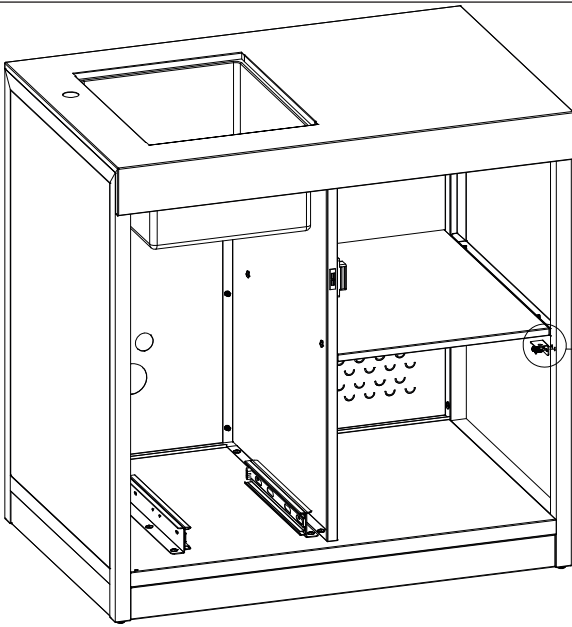

 M4x12 2PCS

13

27

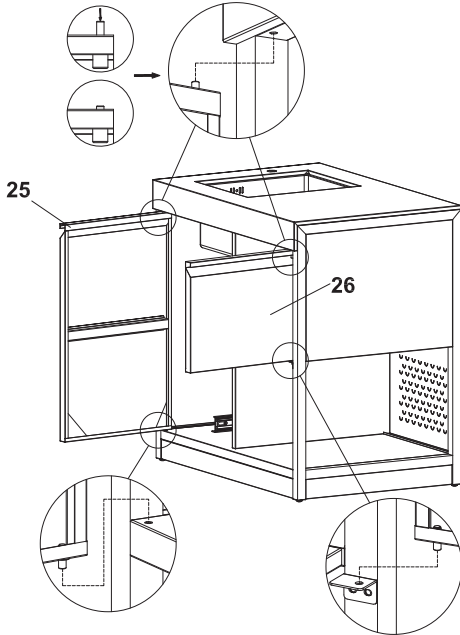

25

26

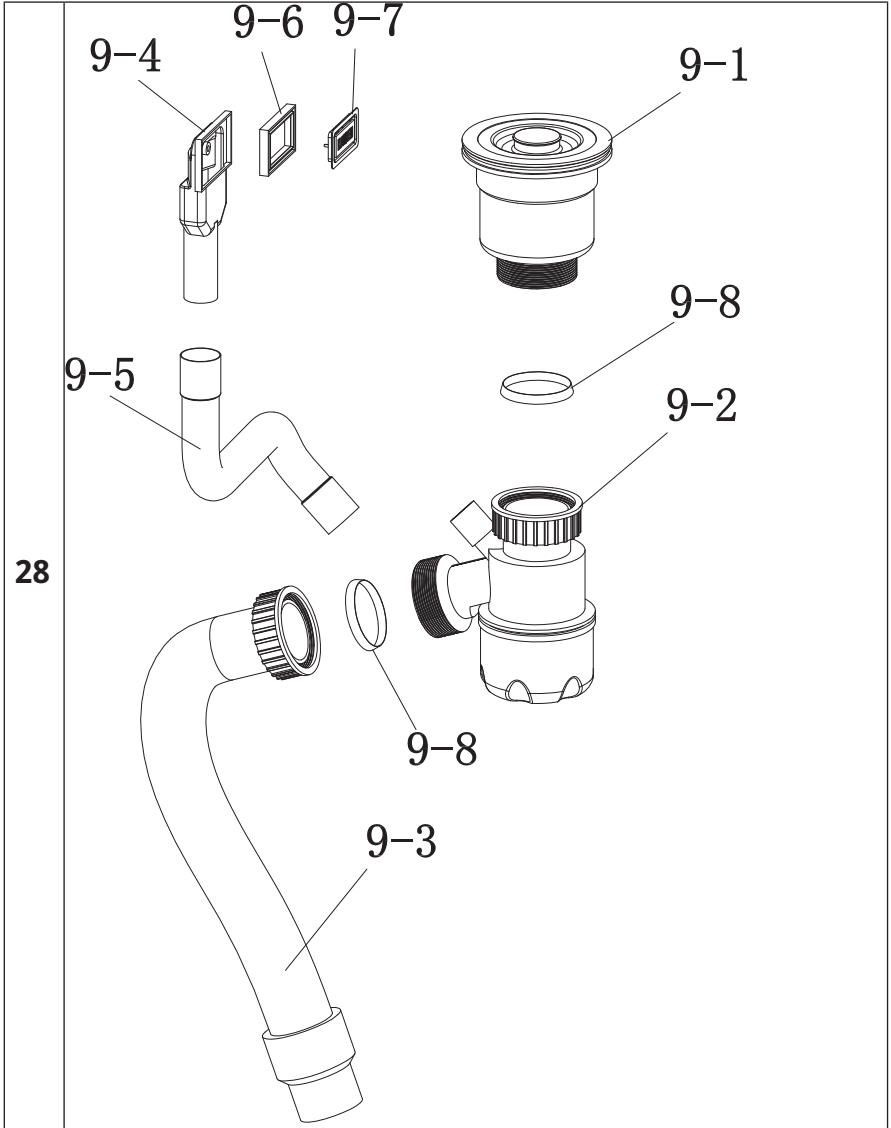

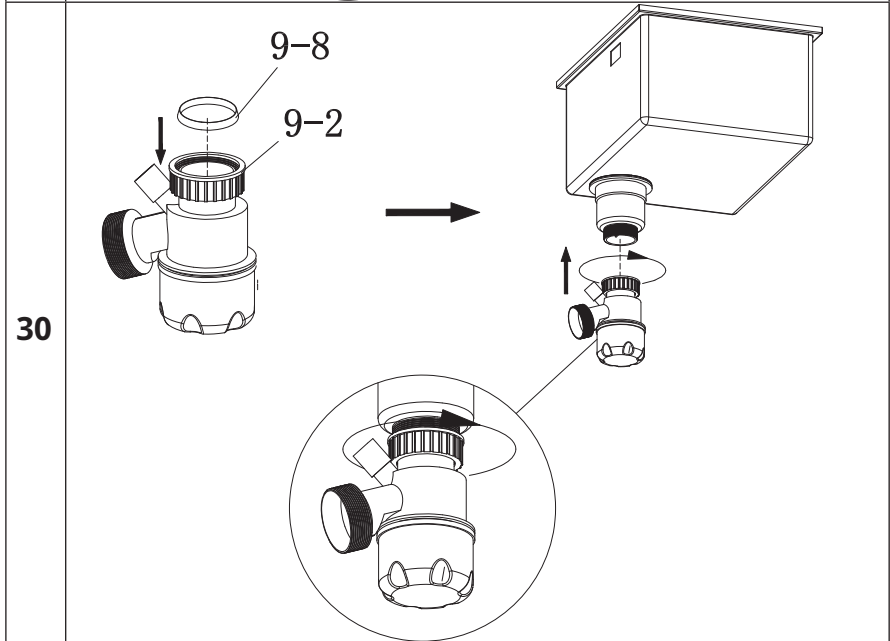
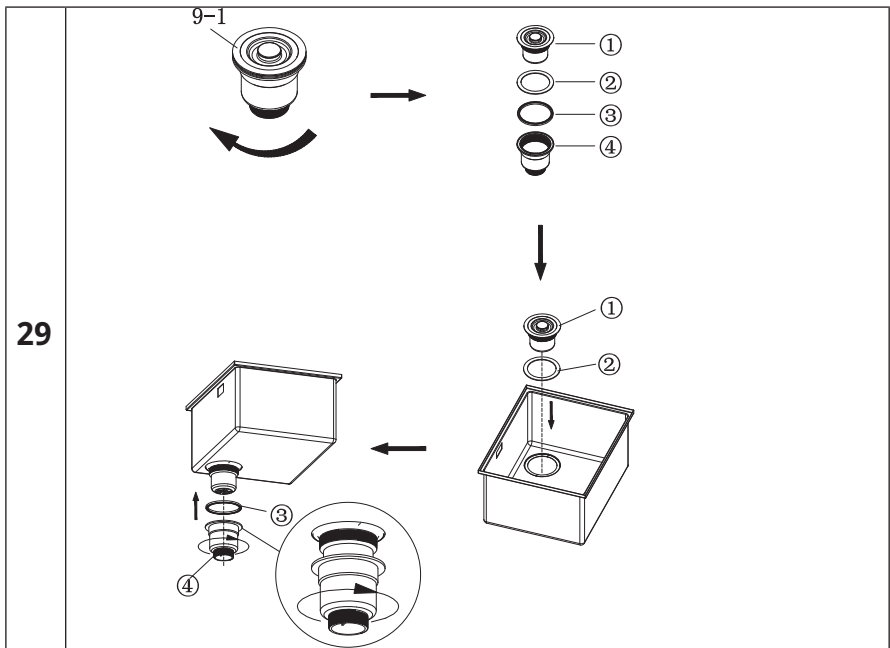

31

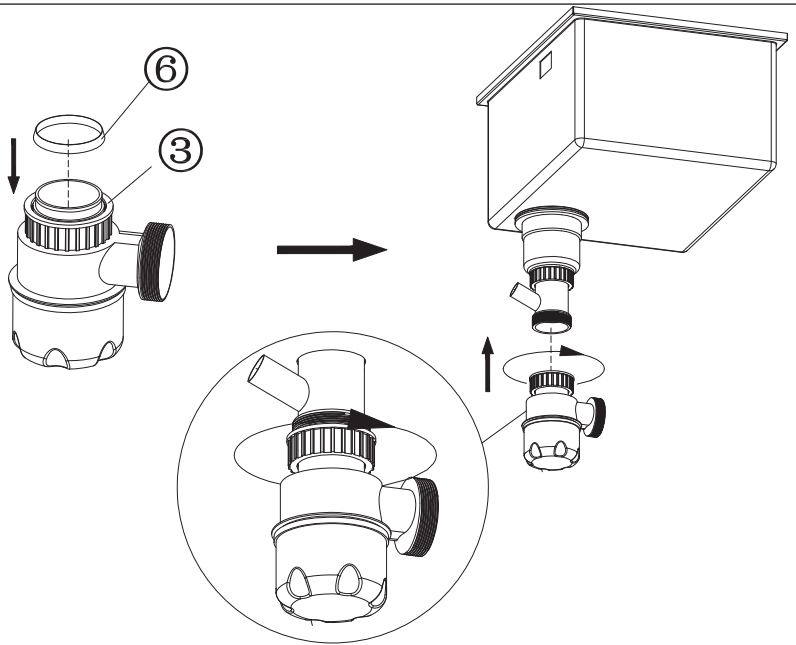

32

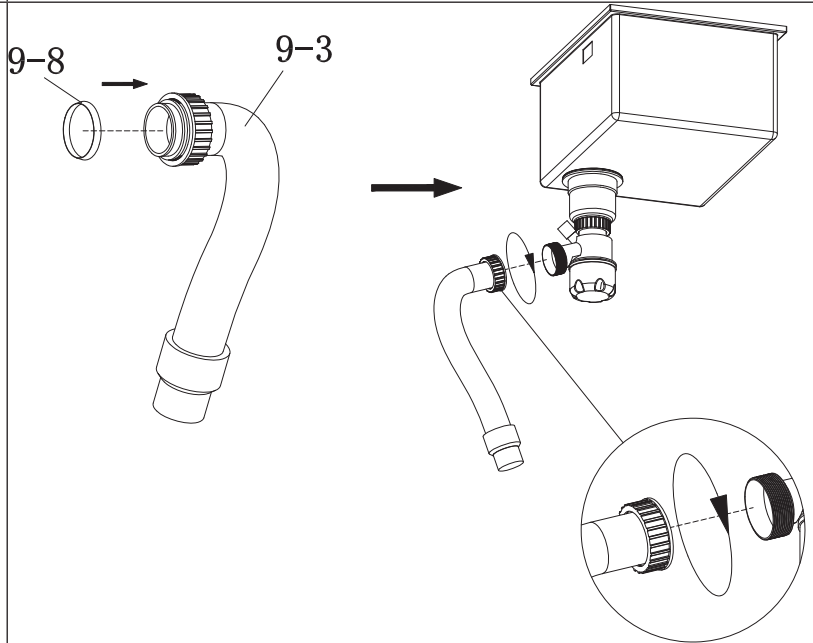

33

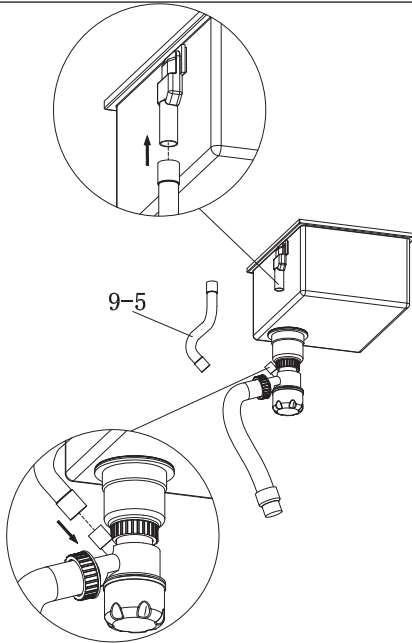

34

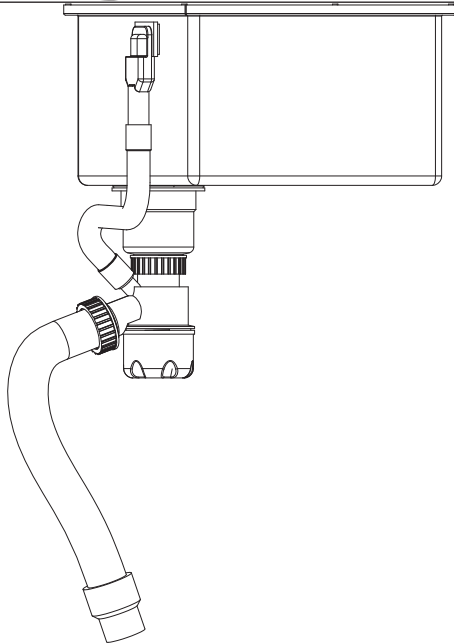

35

17

18

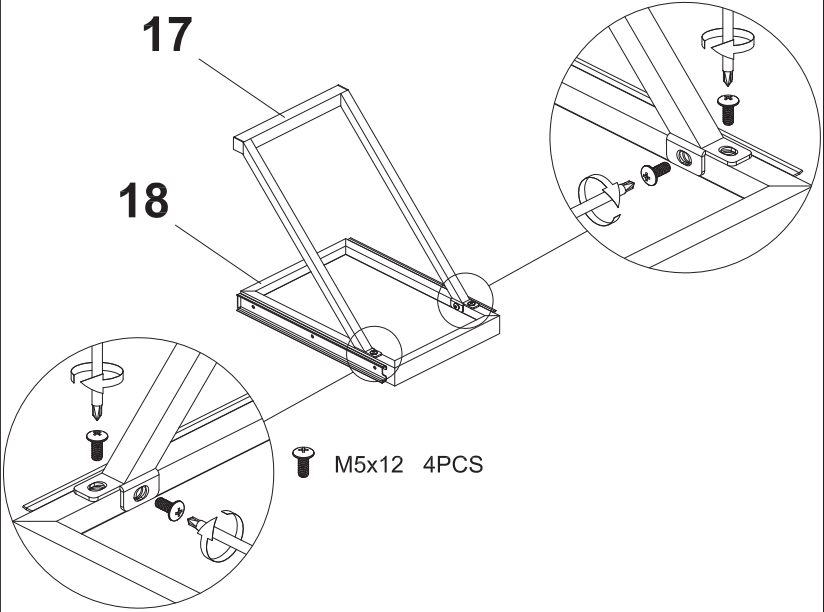

36

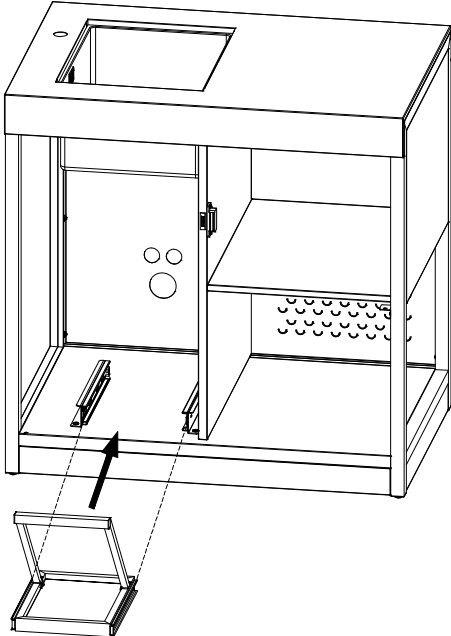

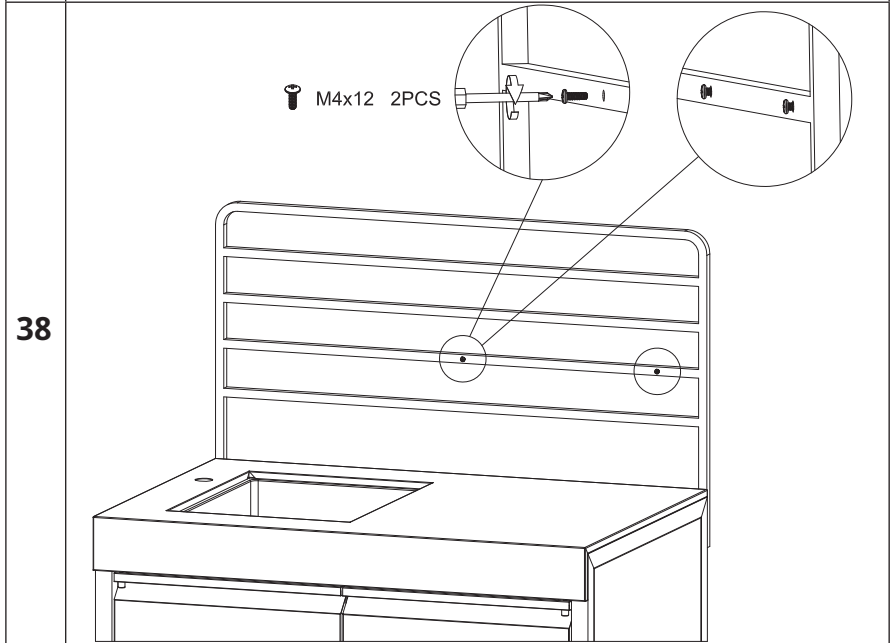
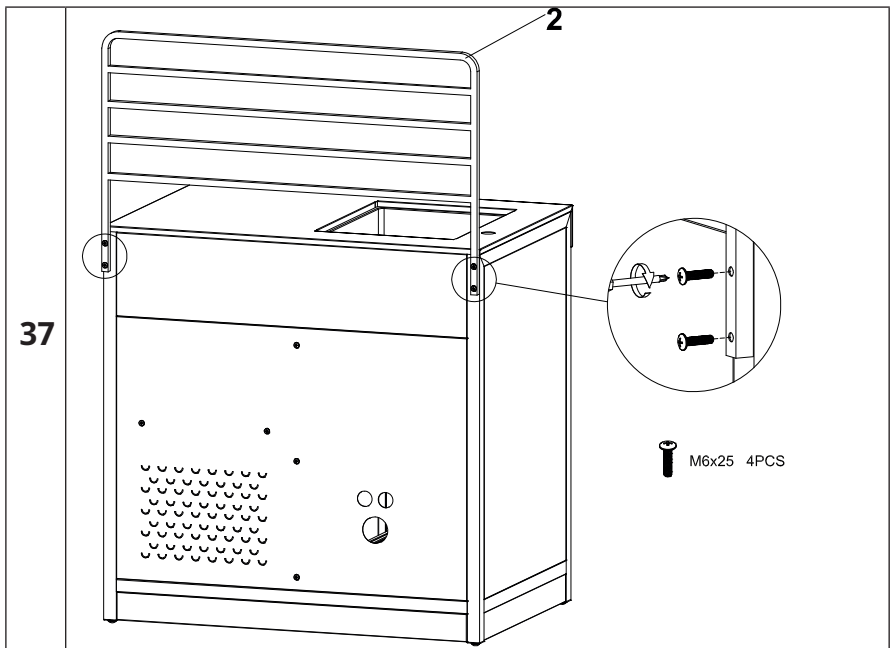

39

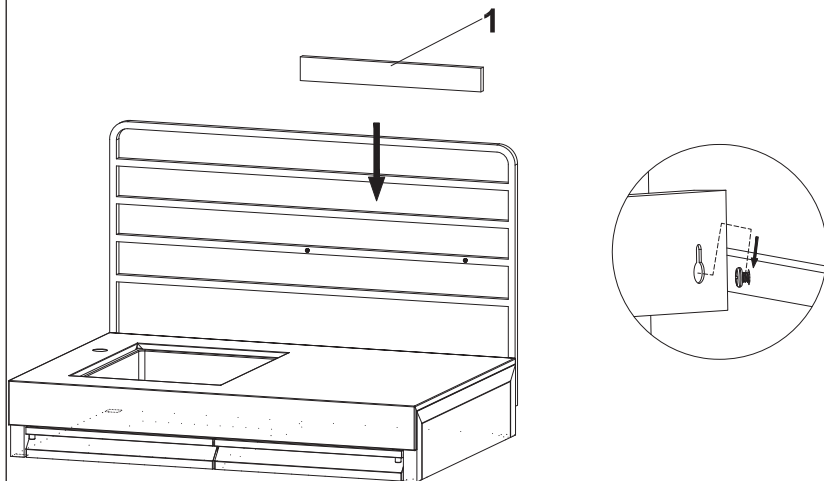

40

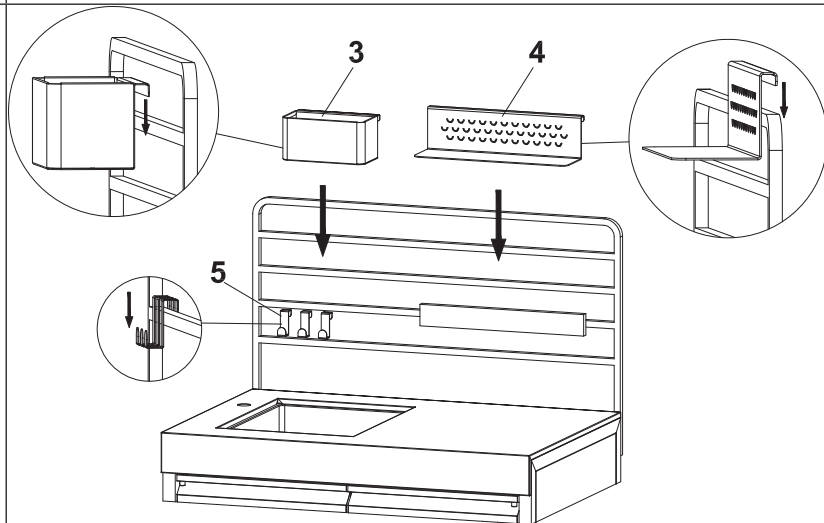

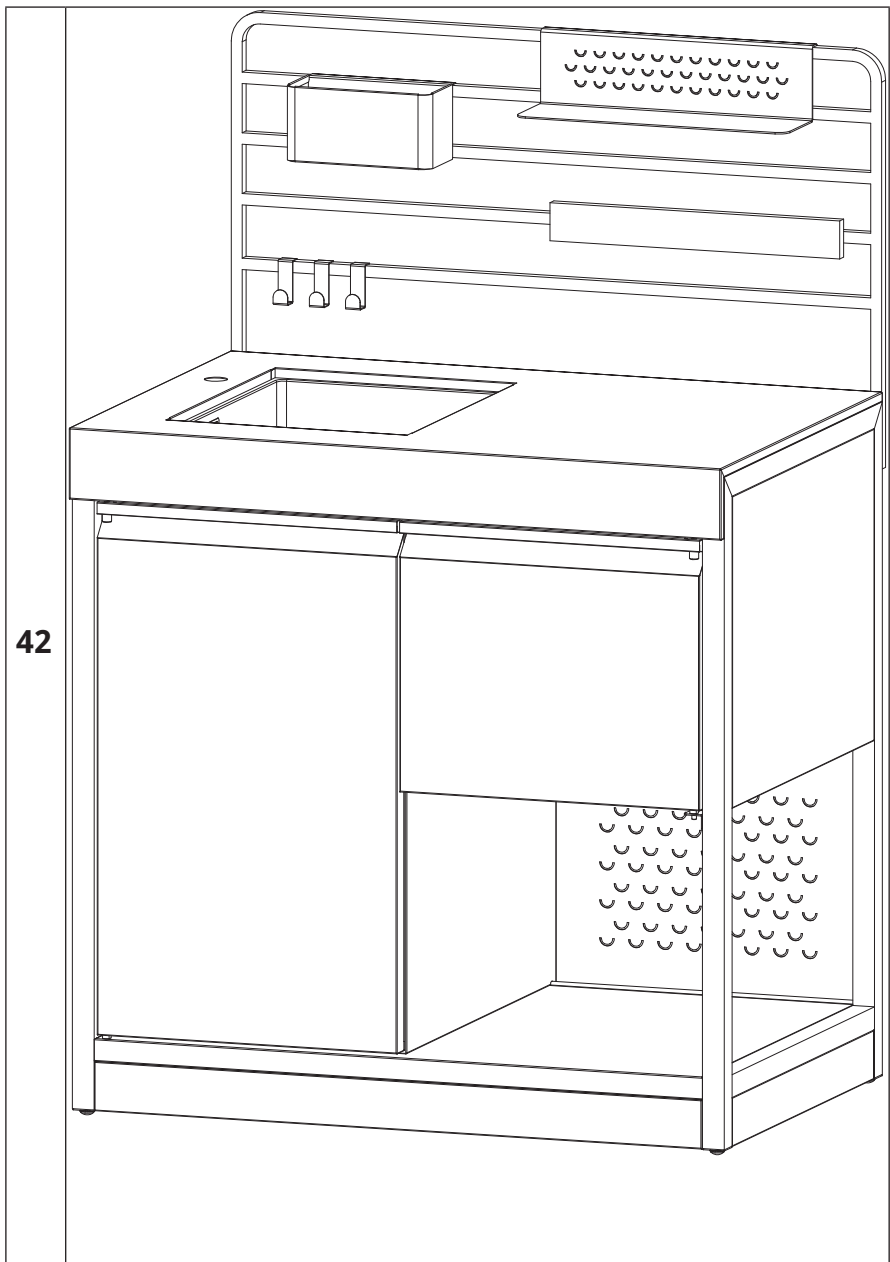

---

## **PFLEGE UND WARTUNG (DE)**

---

- Verwenden Sie zur Reinigung ein weiches oder leicht feuchtes Tuch und wischen Sie anschließend mit einem sauberen, trockenen Tuch nach.
- Stauben Sie das Gerät mit einem trockenen Tuch ab.
- Verwenden Sie keine Reinigungsmittel auf Ammoniakbasis, da diese die Oberfläche beschädigen.
- Lassen Sie keine Flüssigkeiten oder feuchte Tücher auf diesem Möbelstück liegen.
- Überprüfen Sie regelmäßig alle Schrauben und Bolzen und ziehen Sie sie nach, um eine ordnungsgemäße Funktion und Sicherheit Ihres Artikels zu gewährleisten.
- Keine Stahlwolle, Scheuerpulver, harte oder scharfe Utensilien, die die Edelstahloberfläche zerkratzen könnten, verwenden.

---

## **CARE AND MAINTENANCE (EN)**

---

- To clean, use a soft or slightly damp cloth, then wipe with a clean, drycloth.
- Dust with a soft dry cloth.
- Do not use ammonia-based cleaning products, as they will damage the finish.
- Do not leave liquids or damp cloths on this furniture.
- Please inspect and tighten all screws or bolts on a regular basis to ensure proper performance and safety of your item.
- Do not use steel wool, scouring powder, hard or sharp utensils that could scratch the stainless steel surface.

---

## **CUIDADO Y MANTENIMIENTO (ES)**

---

- Para limpiarlo, utilice un paño suave o ligeramente humedecido y, a continuación, séquelo con un paño limpio y seco.
- Limpie el polvo con un paño suave y seco.
- No utilice productos de limpieza a base de amoníaco, ya que dañarán el acabado.
- No deje líquidos ni paños húmedos sobre este mueble.
- Inspeccione y apriete todos los tornillos o pernos periódicamente para garantizar el buen funcionamiento y la seguridad de su artículo.
- No utilice lana de acero, detergentes en polvo, utensilios duros o afilados que puedan rayar la superficie de acero inoxidable.

---

## **ENTRETIEN ET MAINTENANCE (FR)**

---

- Pour le nettoyer, utilisez un chiffon doux ou légèrement humide, puis essuyez-le avec un chiffon propre et sec.
- Dépoussiérez avec un chiffon doux et sec.
- N'utilisez pas de produits de nettoyage à base d'ammoniaque, car ils endommageraient la finition.
- Ne laissez pas de liquides ou de chiffons humides sur ce meuble.
- Inspectez et serrez régulièrement toutes les vis et tous les boulons afin de garantir le bon fonctionnement et la sécurité de votre article.
- Ne pas utiliser de laine d'acier, de poudre à récurer, d'ustensiles durs ou tranchants qui pourraient rayer la surface en acier inoxydable.

---

## **PULIZIA E MANUTENZIONE (IT)**

---

- Per la pulizia, utilizzare un panno morbido o leggermente umido, quindi passare un panno pulito e asciutto.
- Spolverare con un panno morbido e asciutto.
- Non utilizzare prodotti per la pulizia a base di ammoniaca, perché danneggiano la finitura.
- Non lasciare liquidi o panni umidi su questo mobile.
- Controllare e serrare regolarmente tutte le viti o i bulloni per garantire le prestazioni e la sicurezza del prodotto.
- Si prega di non utilizzare paglietta metallica, polvere abrasiva, utensili duri o affilati che potrebbero graffiare la superficie in acciaio inossidabile.









**KLARSTEIN**