



*Give your heating
some time off*

Installation guide and user instructions



Crystal
Mark
19616



Clarity approved by
Plain English Campaign

Thank you for buying the eTRV (electronic thermostatic radiator valve) with infrared remote control. Please read through this manual before using the product, and follow the instructions in it.

This eTRV can only be fitted to a radiator that already has a thermostatic radiator valve, as shown opposite. It has been designed to fit most standard radiator valves (as shown on page 7). In this case, the eTRV is easy to fit and there is no plumbing work involved – you do not need to turn off your water or drain your radiators.



If you have a manual radiator valve, as shown opposite, you will need to have a normal thermostatic radiator valve fitted first. You may need professional help from a heating engineer or registered plumber.



Please take the time needed to read and understand these instructions. After you have read the manual, store it in a safe place.

eTRV is protected under GB Patent, number 2452043.

eTRV is a registered trademark.

2010/10v1

What is a thermostatic radiator valve (TRV)?

TRVs sense the temperature of the air around them and regulate the flow of water through the radiator accordingly. They do not control the boiler.

TRVs should be set at a level that gives you the room temperature you want. These settings may have to be different in each room, and you should set the TRVs to suit each room and then leave them to do their job.

Turning a TRV to a higher setting will not make the room heat up any faster. How quickly the room heats up depends on the boiler and the size and type of radiator. Turning a TRV to a lower setting will result in the room being controlled at a lower temperature, and saves energy.

TRVs need a free flow of air to sense the temperature, so they must not be covered by curtains or blocked by furniture.

TRVs cannot turn off the boiler when the whole house is warm. To do that, your boiler will need to be controlled by a thermostat in a room. The radiator in the room the boiler thermostat is in should not normally have a TRV. If it does, keep the TRV on the maximum setting and adjust the boiler's thermostat as explained in the instructions for your boiler.

Safety Instructions

If you do not use the eTRV correctly, in line with these operating instructions:



- the warranty will end; and
- we will not be liable for any damage or loss whatsoever, including indirect loss, damage to property or personal injury.

- The eTRV, remote control and accessories are not intended for children and must not be used as toys.
- Do not leave packaging material lying around as children might be tempted to play with it, which is extremely dangerous.
- You must only use the product in dry areas indoors, and it must be protected from moisture and water.
- Handle the product with care. It can be damaged through being hit or dropped, even from a low height.
- Do not open the eTRV as it does not contain any parts that you need to service. If the eTRV arrives faulty, return it to where you bought it.

Disposal



The outer box of the packaging is made from 69% recycled material from managed forests and is 100% recyclable.



These instructions are 100% recyclable.



Do not throw this device away with your regular household waste.
You must take electronic equipment to a local tip to be disposed of in line with current regulations.



Never try to recharge standard batteries as they may explode.



Do not take batteries apart or throw them into a fire.
Do not short circuit batteries.



Do not put used batteries in your regular household rubbish. Take them to your local battery-disposal point.

If you need this guide in large print, download the instructions from www.etrv.co.uk.







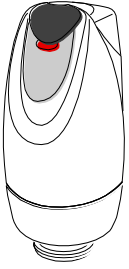

Contents

1	Introduction.....	5
2	General use.....	6
3	Fitting the base ring and spacer.....	6
	3a Choosing the correct base ring.....	7
	3b Choosing the correct spacer.....	8
	3c Attaching the base ring to the eTRV.....	8
4	Batteries.....	9
5	Fitting the eTRV to the radiator	10
6	Factory settings.....	11
	6a What the LED indicator means.....	12
	6b Replacing low and dead batteries.....	12
7	Using your eTRV.....	13
	7a eTRV grey push button.....	13
	7b eTRV remote control.....	14
8	Using as a simple thermostat.....	15
	8a OFF / frost protection.....	16
9	LOW, ECO and COMF.....	16
	9a Changing the stored LOW, ECO and COMF mode temperature settings.....	17
	9b Unlimited temperature control.....	17
	9c Check the temperature of the LOW, ECO and COMF modes.....	17
	9d Boosting from OFF, LOW, ECO or AUTO mode.....	18
10	Individual programmes.....	19
	10a Sleep.....	19
	10b Setting the day and time.....	19
	10c Checking the day and time settings.....	20
	10d Setting quick programmes.....	21
	10e Customised programmes.....	22
	10f Example of a customised programme	24
	10g Deleting day programmes.....	25
	10h Forward to next programme	25
	10i One-hour boost.....	26
	10j +/- 1°C.....	26
11	Checking settings and modes.....	26
	11a Check current mode.....	26
	11b Check temperature set for AUTO mode.....	27
	11c Check the temperature setting.....	27
	11d Check the current room temperature.....	28
12	Extra settings.....	28
	12a Setting maximum and minimum temperatures.....	28
	12b Checking maximum and minimum temperatures.....	29
	12c Setting an “offset” temperature.....	29
	12d Checking the offset temperature.....	30
	12e Cancelling the offset temperature.....	30
	12f Retracting and extending the stem manually.....	31
	12g Lock settings.....	31
	12h Exercising the valve.....	32
	12i Restore factory settings.....	33
13	Technical properties.....	33
14	Programme tables.....	34
15	eTRV quick guide.....	36

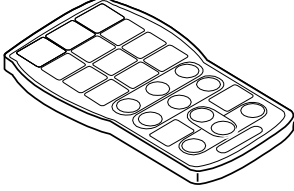
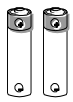
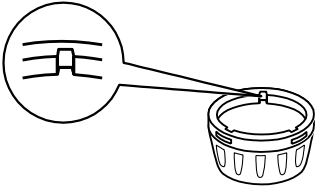
1 Introduction ▲

This manual explains how to install, use and maintain the eTRV. Please keep this manual in a safe place so you can refer to it in the future if you need to.

The box should contain the following items and accessories.

eTRV parts		Remote control (if you ordered one)
 eTRV	 Three base-ring pegs (3)	 Remote control
 Two AA (LR6) batteries	 28mm base ring	 Remote control CR2025 battery (already in the remote control)
 Instructions	 30mm base ring	
	 2mm-thick spacer	
	 3.5mm-thick spacer	

You will need:

- a Phillips screwdriver (one with a cross tip); and
- pen or pencil to record the eTRV settings.

You may need:

- an adjustable spanner (to remove the existing TRV).

2 General use ▲

Each eTRV controls a radiator valve to regulate the heating in the room, based on time programmes, set temperatures and how the room is used. A remote control and LED indicator (a red, yellow or green light) allows you to programme and use the eTRV easily. Using the eTRV improves your comfort and saves energy.

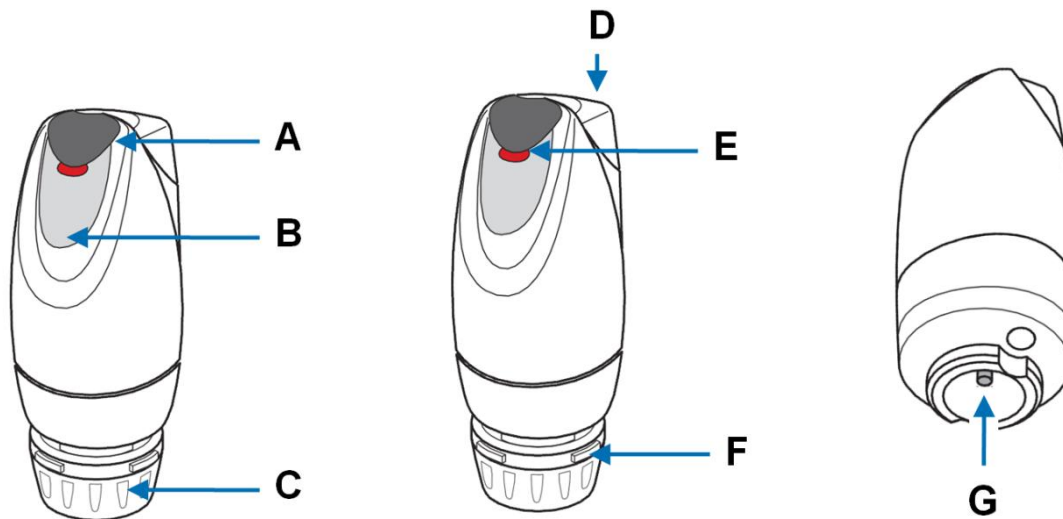

A: Infrared receiver
B: Grey push button
C: Base ring

D: Battery cover
E: LED indicator
F: Base-ring pegs

G: Stem

3 Fitting the base ring and spacer ▲

The first step is to remove your existing TRV head.

Step 1

Turn the TRV thermostat **anticlockwise** as far as it will go.

Step 2

Release the base by turning it **anticlockwise**, by hand or with a spanner.

Step 3

Pull the existing TRV thermostat off the valve.

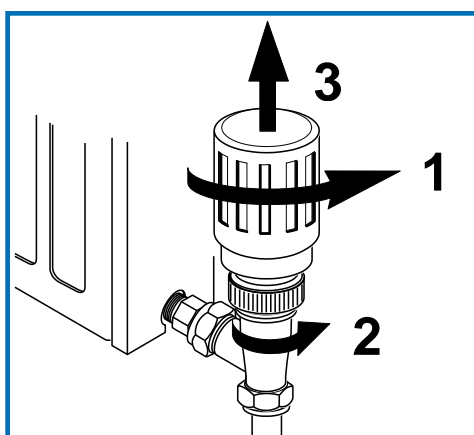

Removing the existing vertical TRV

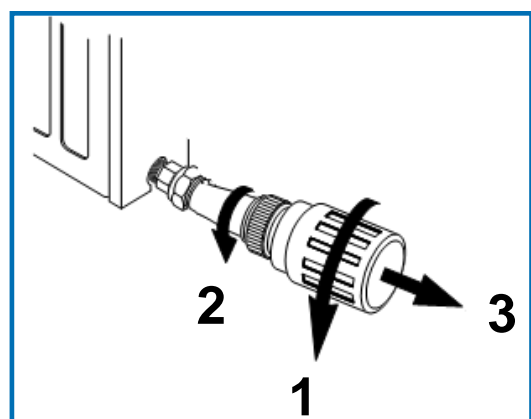

Removing the existing horizontal TRV

There are base-rings and spacers that allow your eTRV to fit to either 28mm or 30mm radiator valves, whichever is already on your radiator.

The eTRV is compatible with valves made by:

- Barlo
- Braukmann
- Drayton
- Honeywell
- Landis & Gyr DuoGyr
- Myson
- Pegler
- Regis (B&Q)
- Siemens

and many others.

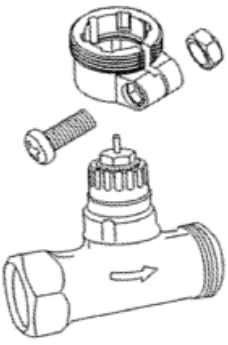
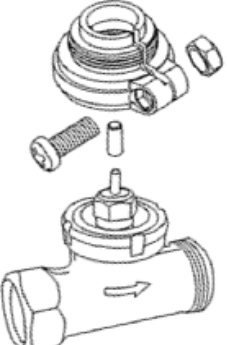
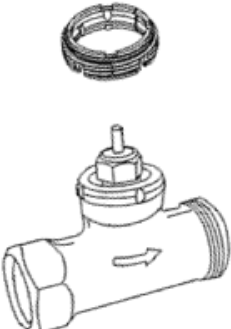
		
Danfoss RA	Danfoss RAV	Danfoss RAVL
<p>If you have an RA or RAV valve, you must fit the adaptor with the nut and bolt that comes with the adaptor.</p> <p>In the case of the RAV adaptor, the extension provided with the adaptor must be attached to the valve tappet</p>		<p>The adaptor must be placed on the valve and tightened.</p>

If you currently have Danfoss RA, RAV or RAVL valves (see above) you will first need to fit special adaptors. Please contact your stockist.

3a Choosing the correct base ring ▲

There are two base rings – 28mm (which has notches inside it) and 30mm (with no notches).

It is important that you use the correct size base ring for your valve. To check which one to use, remove the existing TRV as shown on page 6.

To identify which base ring to use, take one and screw it onto the radiator valve, **before** attaching to the eTRV, to see if it fits.

When you have found the correct base-ring, unscrew it so you can attach it to the eTRV.

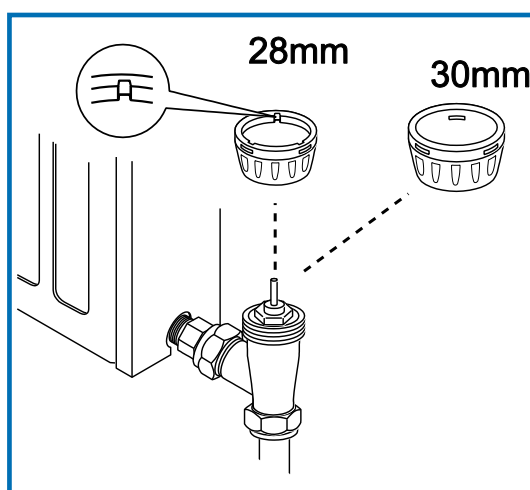

Important

- Test which base ring fits each radiator valve before attaching it to the eTRV.
- Your radiators may have different sized valves in different rooms, so check each one.

3b Choosing the correct spacer ▲

In most cases (where the valve pin is taller than 14mm), you will need to fit a spacer inside the base ring. The spacer comes in two thicknesses, 2mm and 3.5mm. It is important that you use the correct size spacer.

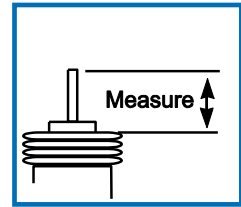

Tip – the 3.5mm-thick spacer is the same thickness as a £1 coin.

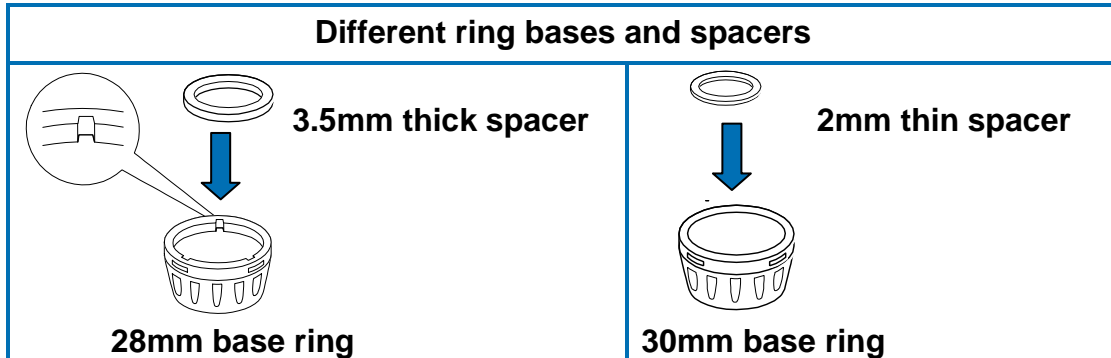

Important

- If you need to use a spacer, put it in place in the base ring before you attach the base-ring to the eTRV.

Once the spacer is in place, attach the base-ring to the eTRV.

3c Attaching the base ring to the eTRV ▲

Step 1

Put the correct spacer (if one is needed) in the base ring.

Step 2

Fit the base ring onto the eTRV.

Step 3

Firmly push the three base-ring pegs into the slots on the base ring.

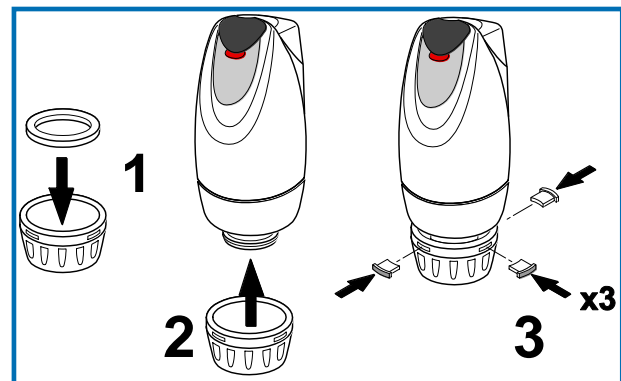

If you ever need to remove the base ring from the eTRV, follow the steps below.

Step 1

Insert a 5mm, thin flat-head screwdriver under the peg.

Step 2

Prise out pegs from base-ring. Take care not to lose any of the pegs.

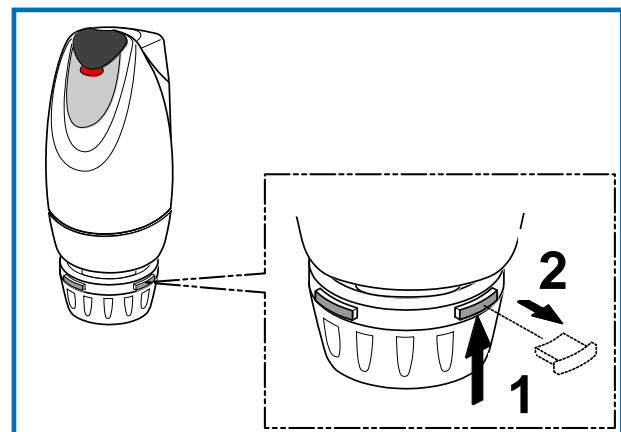

Note

- Keep the unused base ring and spacers in case you fit a different size radiator valve in the future.

4 Batteries ▲

Remote control battery

Pull the plastic tab out of the battery-compartment. There is already a battery in the remote control. But for future reference, below we explain how to replace the battery.

Step 1

Push the clip, which has a hole in it, to the right.

Step 2

Pull out the battery holder.

Step 3

Pull out the CR2025 battery and replace it with a new one, with the side showing the positive (+) symbol facing upwards.

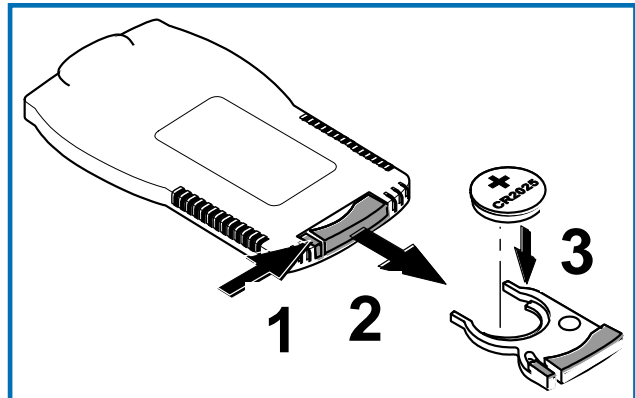

Step 4

Push the battery holder back into remote control.

Inserting the eTRV batteries

Step 1

Using a Phillips screwdriver (one with a cross tip), unscrew the screw at the top of the battery-compartment, but do not remove the screw.

Step 2

Remove the battery-compartment cover, with the screw still in it.

Step 3

Insert the two AA (LR6) alkaline batteries that came with the eTRV into the battery compartment as shown. Make sure you put the batteries in the right way. Inside the battery cover there is a diagram showing which way to fit the batteries when looking from the front of the eTRV.

Step 4

Put the battery-compartment cover back on. Hold it in place while you fully tighten the screw.

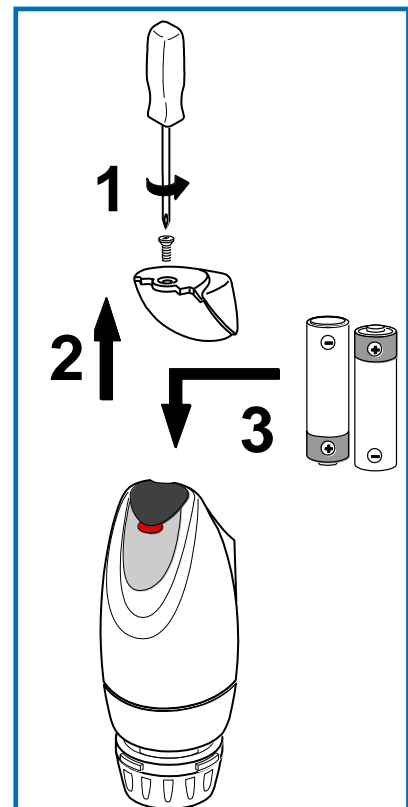

The motor will automatically start to retract the stem (pull it in). The LED indicator will continuously flash red while the motor is running (this could take up to two minutes). Once the stem is fully in, the red light will flash five times every five seconds.

Important

The batteries provided with the eTRV will last for up to 2½ years, depending on how often the motor runs. When you need to replace the batteries, insert new high-quality AA alkaline batteries. Do **not** use rechargeable batteries.

5 Fitting the eTRV to the radiator ▲

You can fit the eTRV vertically or horizontally (see the diagram), depending on the way the existing radiator valve is pointing.

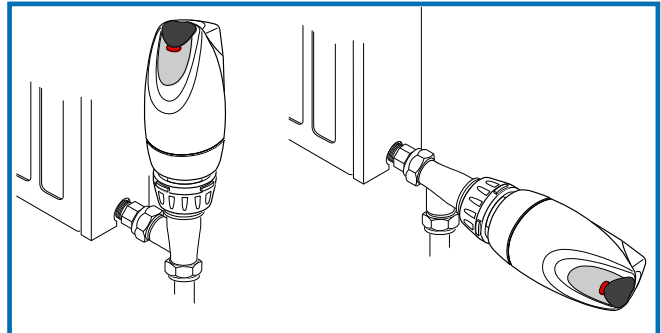

Attaching the eTRV

Before you attach the eTRV, it is important that the stem is **fully retracted** (in), not extended (out). If you have just fitted the batteries, then the stem will have automatically retracted as shown below.

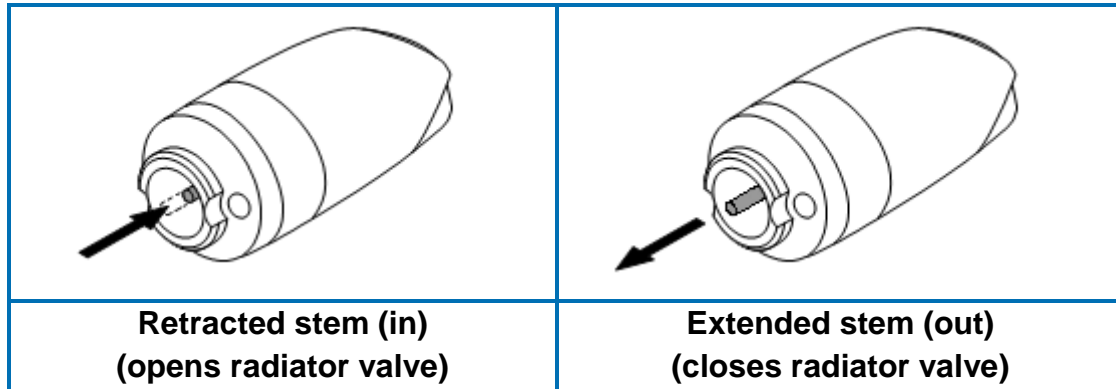

If the stem is extended (see above), take the batteries out and then put them back in again. The motor will automatically come on and start retracting the stem. While the stem is retracting the red LED light will flash continuously. When the stem is fully retracted, the red LED light will flash five times every five seconds.

Important

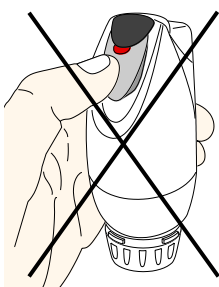

Once the stem has retracted, **do not** press the grey push button on the front of the eTRV until it has been installed correctly on the radiator valve. Pressing the grey push button will cause the stem to extend. If you accidentally press the grey push button, the motor will drive the stem out. In this case you will need to take the batteries out and then put them in again so that the stem will automatically retract.

Once the stem has **fully retracted**, you can safely attach the eTRV to the radiator valve. Remember to have it facing forwards, with the LED indicator pointing forwards.

Step 1

Place the eTRV on the valve.

Step 2

Carefully screw the base ring **clockwise by hand** until it is firmly in place.

Be sure that the eTRV is not blocked by furniture, curtains and so on. To be able to use the remote control easily, you need to be able to see the eTRV.

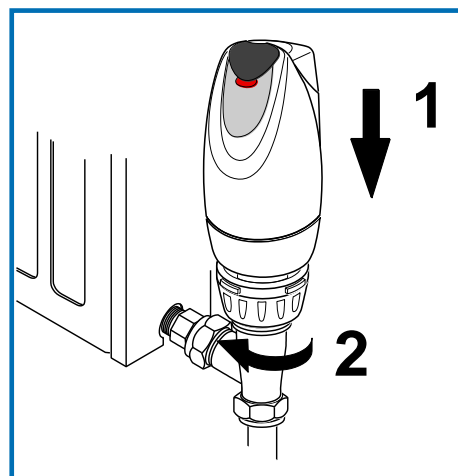

Important

Do not tighten the base ring too much as this may cause the pegs to push out from their slots.

Starting the eTRV

1. Press and release the grey push button on the eTRV to extend the stem and fully close off the radiator valve. This could take up to two minutes. While the motor runs, the red LED light will blink continuously. When the valve is fully closed, the red LED light will flash four times every five seconds.
2. Press and release the grey push button again. The red LED light will blink three times every five seconds to indicate that no programme or mode has been set. The LED indicator will stop blinking after one hour if you do not take any further action.
3. The eTRV comes with a temperature setting of 19°C. It will control the radiator to that temperature unless you change the setting to a different temperature (see section 7 on page 13).

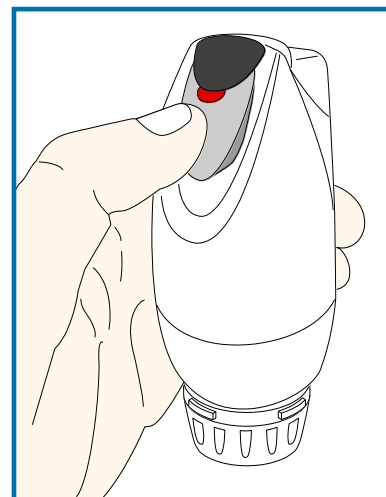

6 Factory settings ▲

Your eTRV comes with temperatures and control settings stored in its memory. It will work to these settings until you change them.

6a What the LED indicator means ▲

The LED indicator flashes red, yellow or green to tell you what the eTRV is doing and it's setting.

	Lights	Meaning
1	● Red light flashes once every five seconds	Dead battery needs replacing (see 6b below)
2	●● Red light flashes twice every five seconds	Low battery needs replacing (see 6b below)
3	●●● Red light flashes three times every five seconds	No programme or mode set (flashing stops after 1 hour)
4	●●●● Red light flashes four times every five seconds	Valve fully closed
5	●●●●● Red light flashes five times every five seconds	Valve fully open
6	● Red light flashes continuously	Motor is running (wait until it's finished)
7	● Green light constantly on	eTRV is waiting for instructions after 'SET' or '?' on the remote control has been pressed
8	●● Both green and yellow lights flash on at the same time	Button pressed correctly, waiting for another press
9	●●● Red, yellow and green lights flash on at the same time	OK - instructions have been given correctly
10	●●● Three red lights flash at the same time after trying to change a setting	Error - instructions given are not correct
11	●●● Red, yellow and green lights flash, at the same time, twice	eTRV has been reset
12	●● Two red lights flash at the same time after trying to change a setting	eTRV is locked (see section 12g on page 31)
13	●● Two green lights flash at the same time	eTRV is unlocked (see section 12g on page 31)
14	●● Both green and red flash at the same time	Temperature control is 'unlimited' (see section 9b on page 17)

6b Replacing low and dead batteries ▲

Low battery ●●

When the batteries are low, the red LED light will flash twice every five seconds. At this point you should replace the batteries. When you replace the batteries at this stage, all the time settings, temperature settings and programmes are stored so you will not have to reset them. To change the batteries, see section 4 on page 9.

Dead battery ●

When the battery does not have enough charge to power the eTRV motor, the red LED light will flash once every five seconds. At this point, the eTRV's stem will automatically retract so heating will not be controlled.

If you do not change the batteries in good time (one minute), or the batteries lose all their charge, you will need to reset the day and time (see sections 10b). You will always need to set the mode setting or simple thermostat setting after the batteries have been exchanged.

7 Using your eTRV ▲

You can work the eTRV by pressing the grey push button on the front of the eTRV to adjust the temperature setting, or by using the remote control to set programmes and your own settings.

7a eTRV grey push button ▲

You can use the grey push button on the front of your eTRV to:

- check the temperature setting and the actual temperature of the room;
- change the temperature setting (when the eTRV is not locked); and
- boost to comfort temperature setting for an hour (when the eTRV is locked).

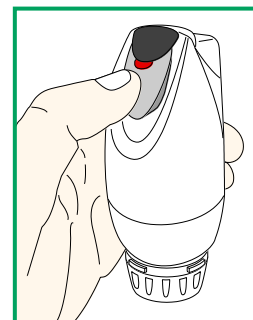

1. Checking the temperature setting and the temperature of the room using the eTRV grey push button

Press and release the grey push button once. The LED indicator will first tell you the temperature setting with a number of green flashes, and then tell you the actual temperature with a number of red flashes. The table below shows what the flashing means.

 Green flashes	Temperature setting
Light on for two seconds	10°C
One flash	16°C
Two flashes	17°C
Three flashes	18°C
Four flashes	19°C
Five flashes	20°C
Six flashes	21°C
Seven flashes	22°C
Eight flashes	23°C
Nine flashes	24°C

 Red flashes	Room temperature
Light on for two seconds	Less than 16°C
One flash	16°C
Two flashes	17°C
Three flashes	18°C
Four flashes	19°C
Five flashes	20°C
Six flashes	21°C
Seven flashes	22°C
Eight flashes	23°C
Nine flashes	24°C

For example, if the eTRV is set to 19°C, and the actual temperature of the room is 21°C, the LED indicator will flash green four times. There will be a two-second pause and then the red light will flash six times.

2. Changing the temperature setting using the eTRV grey push button (when the eTRV is not locked)

If the eTRV is not locked (see section 12g on page 31), press and hold the grey push button for two seconds and then release it. Each time you do this it increases the temperature setting by 1°C.

If you want to reduce the temperature setting, you first need to increase it to 24°C. The next two-second press will take the temperature setting down to 10°C. The next two-second press will take the temperature setting up to 16°C. You will then need to increase it 1°C at a time until it gets to the temperature setting you want (see the example below). After the temperature has been set, the green light will flash the appropriate number of times to confirm the new setting (four times for 19°C, five times for 20°C and so on).

For example:

- If the temperature setting is currently 19°C and you want to increase it to 21°C, you will need to press the grey push button twice, holding it in for two seconds each time.
- If the temperature setting is 21°C and you want to reduce it to 19°C, you will need to press the grey push button eight times (four times to drop it back to 10°C and four times to increase it from 10°C to 19°C), holding it in for two seconds each time. See the table on page 13.

3. Boosting to COMF setting for an hour using the eTRV grey push button (when the eTRV is locked)

If the eTRV has been locked using the remote control (see section 12g on page 31), pressing the grey push button and holding it in for two seconds boosts the eTRV to the COMF mode temperature setting for one hour. For example, if the eTRV is locked to control at 19°C and COMF mode is set to 21°C, holding the grey push button in for two seconds temporarily boosts to the 21°C COMF mode setting for one hour.

Note

Locking the eTRV will prevent the grey push button from increasing the temperature by 1°C. See section 12g on page 31 for instructions on how to lock and unlock the eTRV.

When the eTRV is locked, the grey push button can be used to boost the temperature setting for one hour.

7b eTRV remote control ▲

You can use the remote control to operate the eTRV and to check the eTRV settings. To use the remote control, simply point it at the infrared receiver on the front of the eTRV. Firmly press the buttons on the remote control. The LED indicator on the eTRV will flash when it receives the signal from the remote control.

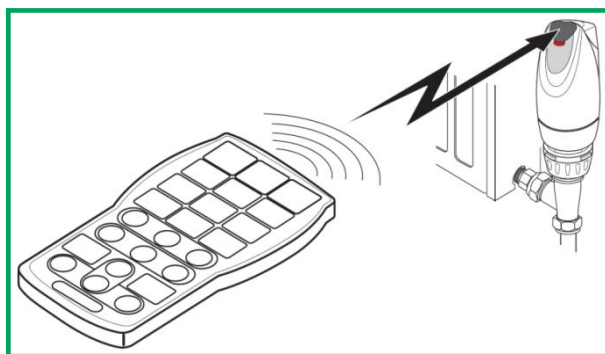

Note

The remote control must be pointed directly at the infrared receiver, and must be no more than five to six metres away from it.

8 Using as a simple thermostat ▲

You can use your eTRV as a simple thermostat, giving you the choice of 10 different temperature settings – off (10°C) and then from 16°C to 24°C. Choose the temperature setting you want by pressing any of the buttons numbered 0 to 9 on the remote control.

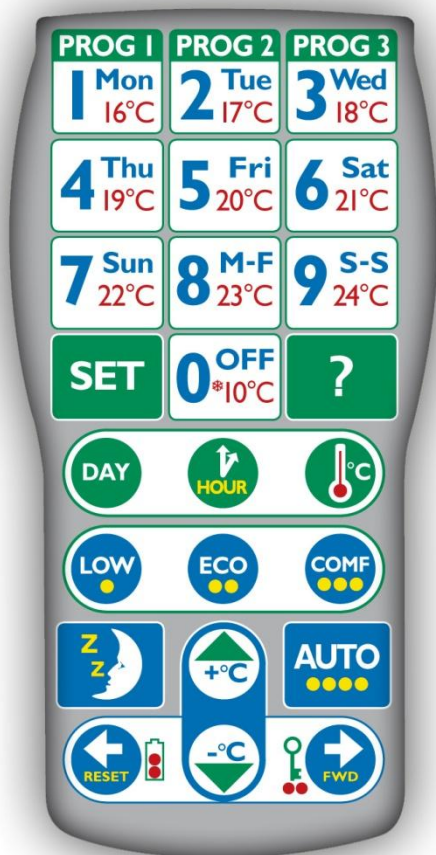

The temperature setting for each button is shown in the table below

Button	Temperature setting
0	10°C
1	16°C
2	17°C
3	18°C
4	19°C
5	20°C
6	21°C
7	22°C
8	23°C
9	24°C

The eTRV will stay on that temperature setting until you change it by pressing another button. If you change the setting, the LED indicator will flash red, yellow then green to confirm that you have successfully changed the setting.

To check the current temperature setting, press:

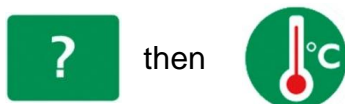

The green light on the LED indicator will flash a number of times to show the temperature setting.

For example, if the temperature is set to 20°C, the green light will flash five times as displayed on the handset.



Number of flashes	Temperature setting
Light on for two seconds	10°C
One flash	16°C
Two flashes	17°C
Three flashes	18°C
Four flashes	19°C
Five flashes	20°C
Six flashes	21°C
Seven flashes	22°C
Eight flashes	23°C
Nine flashes	24°C



When you press the OFF/0 button the eTRV goes into the OFF setting. Use this in the summer to save the battery power.

In the OFF setting, the heating in the room will not come on until the temperature drops to below 10°C, unless you set your own minimum temperature (see section 12a on page 28). This is to prevent the water pipes and radiator from freezing. The one-hour extension (see section 10i on page 26) will still work so you can boost the heating for one hour, after which time it will return to the OFF setting.

To bring your eTRV out of the OFF setting, press any button from 1 to 9, whichever temperature you want (as set out on page 15), or one of the following.



The LED indicator will flash red, yellow then green to confirm the change of setting.

Note

The valve will continue to exercise (see section 12h on page 32)

9 LOW, ECO and COMF ▲

You can use the LOW, ECO and COMF buttons to quickly choose an appropriate temperature for the room.



Pressing any of the LOW, ECO or COMF buttons allows your eTRV to switch to a stored temperature setting for the chosen mode. It will then stay in that mode until you put it in a different mode or change the temperature setting.



LOW – the eTRV goes to the low temperature setting (pre-set to 17°C)



ECO – the eTRV goes to the economy temperature setting (pre-set to 19°C)



COMF – the eTRV goes to the comfort temperature setting (pre-set to 21°C)

You can adjust the temperature settings for these modes as explained in section 9a on page 17. The LED indicator will flash red, yellow and green to confirm the change of setting.

9a Changing the stored LOW, ECO and COMF mode temperature settings ▲

You can change the temperature settings for each mode (LOW, ECO, COMF) to any temperature between 16°C and 24°C. When you have changed the temperature, the LED indicator will flash red, yellow then green to confirm that the setting has changed.

Examples

- If you want to change the LOW setting from 17°C to 16°C, press:



- If you want to change the ECO setting from 19°C to 20°C, press:



- If you want to change the COMF setting from 21°C to 22°C, press:



NOTE
When setting the temperature for each mode, LOW should be the lowest temperature you set and COMF should be the highest temperature you set.

The LED indicator will flash red, yellow then green to confirm the change of setting.

9b Unlimited temperature control ▲

You can also set the COMF setting to unlimited, so the heating is not controlled to a set temperature. This can be used where a radiator is enclosed in a decorative housing and temperature control may be inappropriate.

- To change the COMF setting to unlimited, press:



The LED indicator will flash red, yellow then green to confirm the change of setting.

Note

● ● When COMF mode is set to unlimited, the LED will flash green and then red when checking the temperature setting.

9c Checking the temperature setting of the LOW, ECO and COMF modes ▲

The eTRV can confirm the LOW, ECO and COMF temperature settings by using the  button on the remote control and then the appropriate LOW, ECO or COMF button.

Examples

To find out the LOW mode temperature, press:

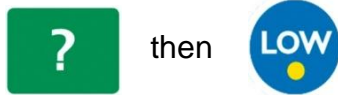

To find out the ECO mode temperature, press:

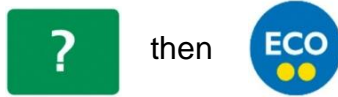

To find out the COMF mode temperature, press:

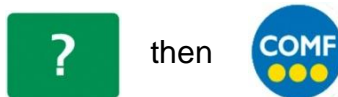



The green light on the LED indicator will flash a number of times to show the temperature setting.

Number of flashes	Temperature setting
Light on for two seconds	10°C
One flash	16°C
Two flashes	17°C
Three flashes	18°C
Four flashes	19°C
Five flashes	20°C
Six flashes	21°C
Seven flashes	22°C
Eight flashes	23°C
Nine flashes	24°C

For example, if the temperature is set to 20°C, the green light will flash five times.



When the COMF mode is set to unlimited, the LED will flash green and then red when checking the temperature setting of the mode.

One green flash and one red flash  	Unlimited
---	-----------

9d Boosting from OFF, LOW, ECO or AUTO mode ▲



When in the OFF, LOW, ECO or AUTO mode you can boost the temperature setting, for one hour, to the COMF mode temperature setting. For more details, see section 10i on page 26. The LED indicator will flash red, yellow then green to confirm the temporary boost.

10 Individual programmes ▲



The AUTO mode allows you to store up to three heating programmes for each day – one programme for the morning, one for the afternoon and one for the evening. Each programme consists of three parts.



Days you want the radiator to come on and go off



Times you want the radiator to come on and go off



Temperature mode you want to control to (see section 9)

The heating control is off (with a temperature setting of 10°C) between programmes unless you set your own minimum temperature (see section 12a on page 28).

For each day, choose the best times and temperatures in each room to maintain a suitable level of heating. This allows you to save energy by reducing the need to heat rooms that are not used at certain times of the day (for example, not heating bedrooms during the day). You can set your own customised programmes (see section 10e), or use quick programmes stored in the eTRV (see section 10d). You can keep a record of settings using the tables in section 14 on pages 34 and 35.

10a Sleep ▲



When in AUTO mode, pressing SLEEP turns your eTRV off until the next day when a new programme starts. For example, if a room is no longer being used, pressing SLEEP shuts off the radiator until the next day when a new programme starts. Pressing AUTO or RESET cancels the SLEEP mode and the eTRV will return to the AUTO mode and so whatever programme you have set.

Note

The SLEEP temperature setting is fixed at 10°C unless you set your own minimum temperature (see section 12a on page 28).

The SLEEP button only works when the eTRV is in AUTO mode.

10b Setting the day and time ▲

The first step in setting up a programme is to set your eTRV clock with the current day and time, as explained below. The time should always be entered in 24-hour format, with hours being entered first. (For example, for 8:10am input 08:10, and for 2:30pm input 14:30.)

To set the day

Press  then 

Then press the button on the remote control for the appropriate day.

For example, if you want to set Friday, press 

Then press 

The LED indicator will flash red, yellow then green to confirm the change of setting.

To set the time

Press  then 

Then press the buttons to input the appropriate time. For example, if it's 2:30pm (14:30), press

 then  then  then 

Then press 

The LED indicator will flash red, yellow then green to confirm the change of setting.

If you make a mistake setting the time, three red lights flash on the LED indicator. Try again until the LED indicator shows red, yellow then green.

Note

The programme you set will only work as you want it to if you have set the correct day and time.

10c Checking the day and time settings ▲

You can check that the eTRV is set to the correct day and time.

To check the day

Press  then 

The green LED light will flash up to seven times to show the day, as shown in the table opposite.

For example, Thursday will be indicated by four flashes.









Number of flashes	Day
One	Monday
Two	Tuesday
Three	Wednesday
Four	Thursday
Five	Friday
Six	Saturday
Seven	Sunday

To check the time

Press  then 

The green LED light will flash a number of times to show each separate figure of the time in the 24-hour format, with a two-second pause between flashes. If the figure is '0', the light will stay on for two seconds.

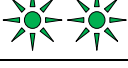
For example, **16:20** would be as follows.

One green flash	
Two-second pause	
Six green flashes	
Two-second pause	
Two green flashes	
Two-second pause	
Green light on for two seconds	

10d Setting quick programmes ▲

Your eTRV comes already set with three quick programmes which you can use straight away. The programmes, which all control the heating to the temperature set for the ECO mode, are as follows.

Programme 1

Radiator comes on at 6am and goes off at 9am, then comes back on from 3pm to 8pm.

Program 1																									
01:00	02:00	03:00	04:00	05:00	06:00	07:00	08:00	09:00	10:00	11:00	12:00	13:00	14:00	15:00	16:00	17:00	18:00	19:00	20:00	21:00	22:00	23:00	00:00	Mode	
					06:00 - 09:00									15:00 - 20:00											ECO

For this programme, press

    Then press  to run the programme.

Programme 2

Radiator comes on at 6am and goes off at 9am, then comes back on from 6pm to 10pm.

Program 2																								
01:00	02:00	03:00	04:00	05:00	06:00	07:00	08:00	09:00	10:00	11:00	12:00	13:00	14:00	15:00	16:00	17:00	18:00	19:00	20:00	21:00	22:00	23:00	00:00	Mode
					06:00 - 09:00												18:00 - 22:00							ECO

For this programme, press

    Then press  to run the programme.

Programme 3

Radiator comes on at 6am and stays on all day until 10pm.

Program 3																												
01:00	02:00	03:00	04:00	05:00	06:00	07:00	08:00	09:00	10:00	11:00	12:00	13:00	14:00	15:00	16:00	17:00	18:00	19:00	20:00	21:00	22:00	23:00	00:00	Mode				
					06:00 - 22:00																							ECO

For this programme, press



Then press



to run the programme.

Simply choose which programme best suits the room.

The programme you choose will be set for every day of the week – the same programme will run each day. For example, setting quick programme 3 has your radiator on from 6am (06:00) to 10pm (22:00), from Monday to Sunday. To set a different programme for a specific day or days, see section 10f on page 24. To cancel a programme for a specific day or days, see section 10g on page 25.

Note

You cannot use more than one quick programme at a time.





















10e Customised programmes ▲

You can set your own customised programmes to suit your household's needs, as shown in the following sections. The eTRV allows you to set up to three programmes a day. For each programme you choose the temperature setting, and the time the radiator goes on and off, to suit the room. The table below shows an example of a Monday programme.

	Programme 1			Programme 2			Programme 3		
	On	Off	Mode	On	Off	Mode	On	Off	Mode
Monday	06:30	08:30	COMF	:	:		16:00	22:00	ECO
Tuesday	:	:		:	:		:	:	
Wednesday	:	:		:	:		:	:	
Thursday	:	:		:	:		:	:	
Friday	:	:		:	:		:	:	
Saturday	:	:		:	:		:	:	
Sunday	:	:		:	:		:	:	

Make a note of your settings for each eTRV in section 14 on page 34.

You set your own customised programme by following the steps below.

Step 1	Press  to start.
Step 2	Choose the programme you want to set – for example, PROG 1 for morning, PROG 2 for afternoon, and PROG 3 for evening. For example: 
Step 3	Press 
Step 4	Choose the day or group of days (Monday to Friday or Saturday and Sunday) you want that programme to run. Press one button to set the programme for: <ul style="list-style-type: none"> • one particular day (for example, Tuesday); • Monday to Friday (M-F) • Saturday and Sunday (S-S)    <div data-bbox="1118 719 1409 931" style="border: 1px solid black; padding: 5px;"> <p>Note Only one of the day buttons can be pressed</p> </div>
Step 5	Set the ON time (the time you want the radiator on from) by pressing  then the buttons that correspond to the time, in the 24-hour clock format. For example, to set an ON time of 6.30am (06:30), press:     
Step 6	Set the OFF time (the time you want the radiator to go off) by pressing  then the buttons that correspond to the time, in the 24-hour clock format. For example, to set an OFF time of 8.30am (08:30), press:     
Step 7	Press 
Step 8	Choose the temperature mode you want between the ON and OFF times. For example: 
Step 9	Press  to confirm.

A typical programme for Monday to Friday is the COMF temperature mode from 6.30am to 8.30, and then the ECO temperature mode from 4pm to 10pm. In this example, no PROG 2 is set as nobody is at home in the afternoon.

To set this programme you would press the following buttons, in the order shown.



Then



If you then wanted to change the programme for the Wednesday, you would amend the set programme by pressing the following buttons in order.



Then



If you then wanted to add programmes for the weekend, you would amend the set programme by pressing the following buttons in order.



Then



Once you have set the programmes you want, press  to run them.

The table below shows what programmes have been entered above.

	Programme 1			Programme 2			Programme 3		
	On	Off	Mode	On	Off	Mode	On	Off	Mode
Monday	06:30	08:30	COMF	:	:		16:00	22:00	ECO
Tuesday	06:30	08:30	COMF	:	:		16:00	22:00	ECO
Wednesday	09:00	10:00	COMF	10:00	14:00	LOW	16:00	22:00	ECO
Thursday	06:30	08:30	COMF	:	:		16:00	22:00	ECO
Friday	06:30	08:30	COMF	:	:		16:00	22:00	ECO
Saturday	09:30	11:00	COMF	11:00	22:00	ECO	:	:	
Sunday	09:30	11:00	COMF	11:00	22:00	ECO	:	:	

10g Deleting day programmes ▲

You can delete the programmes for an individual day or a group of days (Monday to Friday or Saturday to Sunday), as shown below.

Deleting the programme for a single day (for example Thursday) is shown below.



Deleting the programme for a group of days (for example, Monday to Friday) is shown below.



Note

When deleting, pressing PROG 1, PROG 2 or PROG 3 resets the whole day.

10h Forward to next programme ▲



Press this button to move your heating straight on to the next programme. Pressing AUTO, RESET or switching to another temperature mode cancels the override. The LED indicator will flash red, yellow then green to confirm the change of setting.

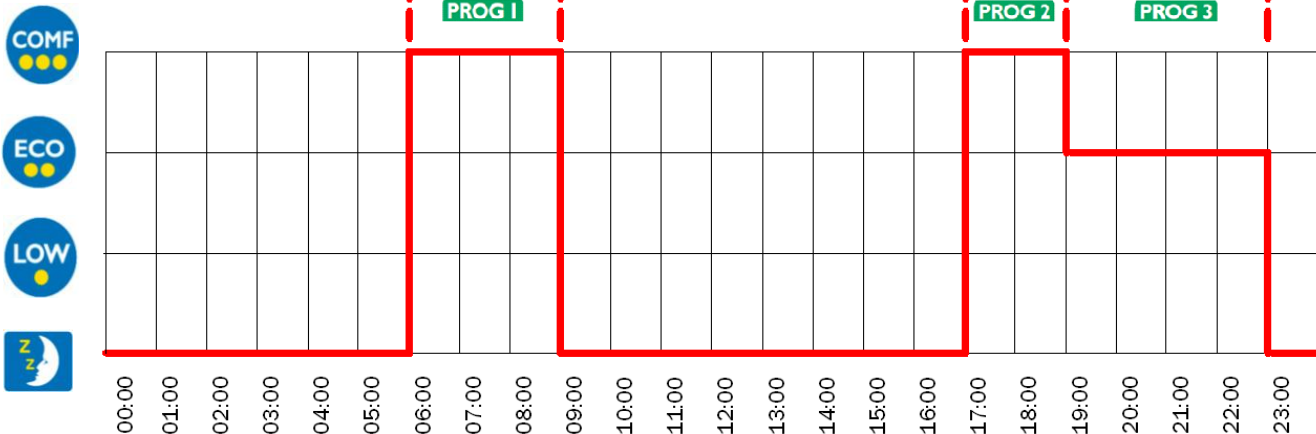

If the programme currently running is PROG 1 and you press the forward button, the heating will move to the period between PROG 1 and PROG 2 (when the radiator is off). If you press the forward button during the period between programmes (for example, during the period between PROG 1 and PROG 2), the heating will go to the next programme, PROG 2.

Note

The forward button will only move on by one programme at a time. For example, double clicking the forward button will result in an error message (three red flashes).

If the next programme is blank, the eTRV will change to this setting. If you press the forward button during the last programme of the day, an error message (three red flashes) will be displayed. It will not go straight to the next day's first programme.

10i One-hour boost ▲



You can press this button to temporarily boost the temperature, for an hour, to the stored COMF temperature setting. The eTRV will automatically go back to the programme setting after one hour. If you press the button again within the hour, for example 30 minutes later, the hour timer starts again. The LED indicator will flash red, yellow then green to confirm the temporary change.

To cancel the one-hour boost, press RESET or any temperature or mode setting. To boost without a handset, see point 3 on page 14.

10j +/- 1°C ▲



Pressing one of these buttons increases or decreases the current temperature setting by 1°C each press until the end of the current programme or one-hour extension period. To confirm the temperature increase or decrease, check the temperature as explained in section 11c on page 27. If you try to increase the temperature above 24°C, or reduce it to below 16°C, the LED indicator will display an error message (three red flashes).

To cancel, press RESET or any temperature or mode setting.

11 Checking settings and modes ▲

Your eTRV allows you to check many of its settings and temperature modes. The LED indicators' response depends on what you are checking.

11a Check current mode ▲

To check the mode your eTRV is currently running, press:

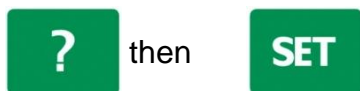

The yellow LED light will flash up to four times, as shown in the table opposite, to show you the mode.

Number of Flashes	Mode setting	
Light stays on for two seconds	OFF	or a temperature is set below LOW
One flash	LOW	or a temperature is set below ECO
Two flashes	ECO	or a temperature is set below COMF
Three flashes	COMF	or a temperature is set above COMF
Four flashes	AUTO mode	

The number of yellow flashes corresponds to the markings on the mode buttons of the handset. For example, the yellow LED will flash three times if in COMF mode (or a temperature setting above the COMF mode temperature).



11b Check temperature set for AUTO mode ▲

To check what temperature mode is currently running in AUTO mode, press:

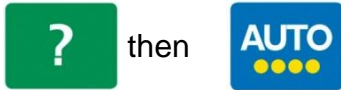

The yellow LED light will flash up to three times, as shown in the table opposite, to tell you the temperature mode. The number of yellow flashes corresponds to the markings on the mode buttons of the handset. For example, the yellow LED will flash three times if in COMF mode.

Number of flashes	Mode setting
Light stays on for two seconds	No mode set
One flash	LOW
Two flashes	ECO
Three flashes	COMF

Note

If the yellow light stays on for two seconds, this means that the eTRV is in SLEEP mode, set to a single temperature or has been adjusted using +/-1°C to a temperature other than LOW, ECO or COMF mode temperature. To check the temperature setting, follow the instructions in 11c below.

The COMF mode is always shown if you have pressed the  boost button within the last 60 minutes.

11c Check the temperature setting ▲

To check the temperature setting for the current mode, press:



The green LED light will flash up to nine times, as shown in the table opposite, to tell you the temperature setting. For example, if the green light flashes six times, the temperature setting is currently 21°C.



Number of flashes	Temperature setting
Light on for two seconds	10°C
One flash	16°C
Two flashes	17°C
Three flashes	18°C
Four flashes	19°C
Five flashes	20°C
Six flashes	21°C
Seven flashes	22°C
Eight flashes	23°C
Nine flashes	24°C
One green flash and one red flash 	Unlimited

11d Check the current room temperature ▲

To check the current room temperature, press:



The red LED light will flash up to nine times, as shown in the table opposite, to tell you the room temperature that the eTRV is reading. For example, if the red light flashes five times, the room temperature is currently 20°C.



Note

Checking the temperature will show any offset that has been applied. (see section 12c on page 29).

Number of flashes	Temperature setting
Light on for two seconds	Less than 16°C
One flash	16°C
Two flashes	17°C
Three flashes	18°C
Four flashes	19°C
Five flashes	20°C
Six flashes	21°C
Seven flashes	22°C
Eight flashes	23°C
Nine flashes	24°C

12 Extra settings ▲

The eTRV has the following extra settings.

12a Setting maximum and minimum temperatures ▲

You can set maximum and minimum temperatures. This would prevent anyone from turning the temperature up over the maximum, or down below the minimum. For example, if you do not want a room to be above 21°C, you can set this as the maximum temperature. This means that even if someone presses 24°C on the remote control, your eTRV will limit the temperature to 21°C. Similarly, if you set a minimum temperature of 18°C, your room temperature could not be turned down to less than that, even if someone presses the 17°C button on the remote control. To set a maximum and minimum temperature, follow the steps in the example below. The example is for a maximum of 21°C and a minimum of 18°C.

To set a maximum temperature (for example, 21°C), press the following buttons.



To set a minimum temperature (for example, 18°C), press the following buttons.



The LED indicator will flash red, yellow then green to confirm the change of setting.

Note

In SLEEP and OFF mode, the eTRV will control the heating to the minimum temperature that has been set.

12b Checking maximum and minimum temperatures ▲

To check the maximum temperature, press the following buttons.



To check the minimum temperature, press the following buttons.



The green LED light will flash a number of times to show the relevant maximum or minimum temperature set, as shown in the table opposite.

Number of flashes	Temperature setting
Light on for two seconds	No Temp Assigned
One flash	16°C
Two flashes	17°C
Three flashes	18°C
Four flashes	19°C
Five flashes	20°C
Six flashes	21°C
Seven flashes	22°C
Eight flashes	23°C
Nine flashes	24°C

If no temperature has been set, the green LED light will stay on for two seconds.

12c Setting an 'offset' temperature ▲

If the flow of air around the eTRV is restricted (for example, if it is covered by curtains or blocked by furniture), or the flow of air around the room causes cold and hot spots (for example, because of where furniture is placed or the shape of the room), you can set an 'offset' temperature of up to 3°C. This allows the temperature that the eTRV reads to be shifted either up or down the scale so that fine tuning of the eTRV temperature control can be achieved relative to the installed location. The LED indicator will flash red, yellow then green to confirm the change of setting.

Offset Up	For example, if the temperature in the room was 21°C, however the eTRV was reading 19°C, the offset command can be used to increase the eTRV temperature reading by 2°C so that it controls to the correct level. (To reset, see section 12e on page 30.)
-----------	---

To set an offset temperature up, (for example, +2°C), press the following buttons.



Offset Down	For example, if the eTRV is reading 24°C, however the opposite side of the room is 22°C, the eTRV temperature reading can be decreased by 2°C so that the temperature reading is adjusted. (To reset, refer to section 12e below.)
-------------	--

To set an offset temperature down, (for example, -2°C), press the following buttons.



Note
The maximum offset that can be set is 3°C. This could take up to 30 minutes to show when checking the room temperature (see section 11d on page 28).

12d Checking the offset temperature ▲

You can check the offset temperature the eTRV is set to by pressing the following buttons.



Number of flashes	Temperature setting
Light on for two seconds	No offset temperature
One flash	1°C
Two flashes	2°C
Three flashes	3°C

The LED will flash a number of times, as shown in the table opposite, to tell you the offset temperature adjustment. Where there has been an increase, the green light will flash for every degree above the normal reading. If there has been a decrease, the red light will flash for every degree below the normal reading.

12e Cancelling the offset temperature ▲

To cancel the offset temperature that was an increase, press the following buttons.



To cancel the offset temperature that was a decrease, press the following buttons.



The LED will flash red, yellow then green to confirm the change of setting.

12f Retracting and extending the stem manually ▲

This feature is to completely isolate (close off), or fully open, a specific radiator valve. It should only be used by heating engineers or experienced users who want to close off or open a specific heating circuit for maintenance or to test the system.

To retract the stem and open the valve, press the following buttons.



While the stem is retracting, the red LED light will flash constantly. Once the stem is fully retracted and the valve is fully opened, the red LED will flash five times every five seconds until the eTRV is set again.

To extend the stem and shut off the valve, press the following buttons.



While the stem is extending, the red LED light will flash constantly. Once the stem is fully extended and the valve is fully closed off, the red LED will flash four times every five seconds until the eTRV is set again.

Note

If you use this feature, the eTRV will not control the temperature and the radiator will not automatically react to the temperature changes.

Do not use this feature to turn the radiator off. Instead use the OFF mode (see section 8a on page 16).

12g Lock settings ▲

You can lock the eTRV settings and grey push button to prevent any mode temperature setting (LOW, ECO and COMF) and programmes from being changed.

To lock the eTRV, press the following buttons.

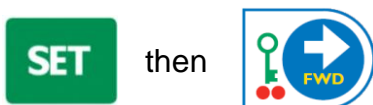

The red LED light will flash twice to show that the eTRV is now locked. The following table shows the settings and functions that will be locked and those that are still available.

Locked features	<ul style="list-style-type: none"> • Adjusting the temperature setting with the grey push button • Setting the day • Setting the time • Setting LOW, ECO and COMF mode temperatures • Changing programmes • Setting maximum and minimum temperatures • Setting the offset temperature • Retracting and extending the stem manually
Available features	<ul style="list-style-type: none"> • Checking the temperature settings and current room temperature using the grey push button • Boosting to COMF mode setting for an hour using the grey push button • Using the eTRV as a simple thermostat including +/-1°C • Switching between modes (LOW, ECO, COMF, AUTO) • Switching between AUTO and SLEEP settings • Restoring factory settings • Checking features (?)

To unlock the eTRV, press the following buttons.



then



The green LED light will flash twice to show that the eTRV is now unlocked.

Note

If anyone tries to use a locked feature while the eTRV is locked, the red LED light will flash twice.

12h Exercising the valve ▲

Some radiator valves can stick after a long period without moving. To reduce the risk of this happening (for example, in the summer when the heating is off), the valve will exercise once a week. This will happen on Sunday night at midnight. The eTRV will automatically extend and retract to exercise all parts.

Note

The day and time setting will have to be correct. If they are not set, the valve will automatically exercise every seven days from when it was installed or reset.

12i Restore factory settings ▲

To reset the eTRV to the settings that were originally stored in it, press the following buttons.



This will restore the temperature of the modes to those set at the factory, and delete all AUTO programmes. The LED indicator will flash red, yellow then green twice to confirm the change of setting.

Note

The day, time clock, programmes, mode temperatures and settings will be lost and the eTRV will control to 19°C until the temperature or mode is changed

13 Technical properties ▲

eTRV	
Controller type	Programmable
Temperature range	10°C to 24°C
Frost-protection temperature	10°C
Temperature range it can be stored in	-20°C to +60°C
Temperature range it will work in	+5°C to +40°C
Maximum circulation temperature	90°C
Application group	Central Generation
Zone type	Maintained or Intermittent
Power supply	Two 1.5V AA alkaline batteries (LR6)
Battery life	Up to 2½ years (depending on use)
Back-up memory	Yes
Size without base-ring (HxWxD)	103mm high, 45mm wide, 45mm deep
Size with base-ring (HxWxD)	120mm high, 45mm wide, 45mm deep
Protection class	IP20

eTRV remote control	
Temperature range it works in	-10°C to +50°C
Temperature range it can be stored in	-20°C to +60°C
Humidity range it can work in	0 to 90% RH
Range from eTRV it works in	Up to 7 metres
Power supply	One 3V CR2025 battery
Battery life	Three years (depending on use)
Size	115mm high, 58mm wide and 8mm high
Protection class	IP20



This product complies with:



- BSEN 60730
- BSEN 60529
- BSEN15500 (Part)
- BSEN 50419

14 Programme table 1 ▲

We recommend that you fill in the table below to keep track of settings and programmes that you have set your eTRV to control to.

Room: _____

		
°C	°C	°C

Maximum Temperature 	Minimum Temperature 
°C	°C

Offset Temperature
+/- °C



	Programme 1 (e.g. morning)			Programme 2 (e.g. afternoon)			Programme 3 (e.g. evening)		
	On	Off	Temp	On	Off	Temp	On	Off	Temp
Example	06:00	08:30	COMF	13:00	15:00	LOW	17:30	22:00	ECO
1 - Monday	:	:		:	:		:	:	
2 - Tuesday	:	:		:	:		:	:	
3 - Wednesday	:	:		:	:		:	:	
4 - Thursday	:	:		:	:		:	:	
5 - Friday	:	:		:	:		:	:	
6 - Saturday	:	:		:	:		:	:	
7 - Sunday	:	:		:	:		:	:	

Programme table 2 ▲

We recommend that you fill in the table below to keep track of settings and programmes that you have set your eTRV to control to.

Room: _____

		
°C	°C	°C

Maximum Temperature 	Minimum Temperature 
°C	°C

Offset Temperature
+/- °C

	Programme 1 (e.g. morning)			Programme 2 (e.g. afternoon)			Programme 3 (e.g. evening)		
	On	Off	Temp	On	Off	Temp	On	Off	Temp
Example	06:00	08:30	COMF	13:00	15:00	LOW	17:30	22:00	ECO
1 - Monday	:	:		:	:		:	:	
2 - Tuesday	:	:		:	:		:	:	
3 - Wednesday	:	:		:	:		:	:	
4 - Thursday	:	:		:	:		:	:	
5 - Friday	:	:		:	:		:	:	
6 - Saturday	:	:		:	:		:	:	
7 - Sunday	:	:		:	:		:	:	

15 eTRV quick guide ▲

