

ReFit T5 Installation guide



Thank you for buying the ReFit T5 kit from Chalmor. Please read through this manual before using the product, and follow the instructions in it.

The ReFit T5 kit is used to upgrade most standard fluorescent light fittings from T8 or T12 fluorescent fittings to modern T5 high frequency fittings. The ReFit T5 helps to achieve energy savings without the need to replace the entire light fitting.

The installation of the ReFit T5 kit should only be undertaken by a competent person such as an approved electrician or electrical contractor registered with the NICEIC or ECA, or a suitably qualified person.

REGISTERED MEMBER



In any event the best practise of BS7671 and other local regulations must be followed.

If you need any further advice, please contact Chalmor on 01582 748700 or see our web site www.chalmor.co.uk

Please take the time needed to read and understand these instructions. After you have read the instructions, keep them to refer to during the installation process and then store them in a safe place. A copy should be retained for the site Health and Safety file and for the site Operation and Maintenance Manual.

Suitability of ReFit T5 for existing light fittings

The majority of general light fittings will be suitable for upgrade with ReFit T5. These include surface mounted fittings and flush fittings with T8 or T12 lamps, with magnetic conventional control gear (CCG), with low loss gear (LLG) and with electronic control gear (ECG).

There are some light fittings which are not suitable for ReFit T5, which include:

- Protection class II fittings without PE conductors
- Sealed fittings in areas with high ambient temperatures
- Fittings with built in emergency lighting control gear - the existing emergency packs and batteries will not be suitable for use with the ReFit T5. These fittings can only be upgraded if alternative emergency packs are fitted, or if stand alone emergency lighting is installed to support the general lighting. (These fittings can be easily identified as they will normally incorporate an LED indicator, or the room or site will be fitted with Emergency Lighting Testing key switches or automatic controls. These can be operated to establish which fittings have emergency features; some sites may also have a log book listing the emergency lighting.)
- Fittings that cannot accommodate or support the parts included in the ReFit T5 kit. For example, some architectural / designer lighting may not have a suitable position to attach the T5 lamp clips within the existing fitting.

We recommend that prior to undertaking the installation of the ReFit T5 kit, that each type of light fitting is assessed for suitability at a pre-installation survey stage.

Safety Instructions

If you do not fit the ReFit T5 correctly, in line with these installation instructions:



- the warranty will end; and
 - we will not be liable for any damage or loss whatsoever, including indirect loss, damage to property or personal injury.
-
- You must only use the product in dry areas indoors, and it must be protected from moisture and water.
 - Handle the parts with care. They can be damaged through being hit or dropped, even from a low height.
 - Do not open the electronic control gear as it does not contain any parts that you need to service. If the parts arrive damaged or faulty, return it to where you bought it.

Disposal



The outer box of the packaging is made from 69% recycled material from managed forests and is 100% recyclable.



These instructions are 100% recyclable.



Do not throw the ReFit T5 kit away with your regular waste.

You must take electronic equipment to a local tip to be disposed of in line with current regulations.



Use of the ReFit T5 kit will normally result in redundant items which must be disposed of in line with current regulations, and the WEEE directive. This includes recycling of metal and wiring at an approved facility.



Use of the ReFit T5 kit will normally result in redundant fluorescent lamps that are considered hazardous waste and must be recycled at an approved facility, and transported by a licensed waste carrier approved by the Environment Agency.



Chalmor is a member of Lumicom which gives our customers free access to nominated recycling centres. For jobs with 1,000 or more waste lamps Lumicom can provide free recycling, free lamp coffins and free transportation. A refundable deposit will be required for the lamp coffin. To arrange this free service, please call Recolight on 0845 601 7749.

If you need this guide in large print, download the instructions

www.chalmor.co.uk

Contents

1	Identifying the ReFit T5 kit.....	4
2	Single lamp ReFit T5 kit	5
3	Twin lamp ReFit T5 kit.....	6
4	Preparing the fitting.....	7
5	Installing the ReFit T5 kit.....	8
6	Wiring the ReFit T5 kit	9
7	Prepare for connecting the ReFit T5 kit.....	10
8	Attaching the T5 Terry clips.....	11
9	Prepare for the lamp holders.....	12
10	Connecting the lamp holders.....	13
11	Final assembly.....	14
12	Testing.....	15
13	Technical properties.....	15
14	Wiring diagrams	16

1 Identifying the ReFit T5 kit ▲

Before commencing the installation, use the following chart to identify the type and length of fluorescent fittings you have, and the ReFit T5 kits and the T5 lamps you require.

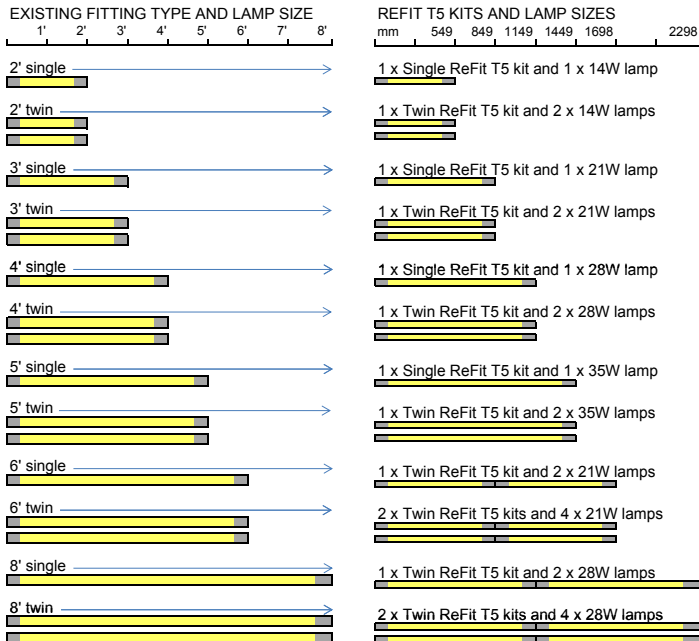

2 Single lamp ReFit T5 kit ▲

This manual explains how to install, use and maintain the ReFit T5 kit. Please keep this manual in a safe place so you can refer to it in the future if you need to.

You will need:

- a Phillips screwdriver (one with a magnetic tip)
- a set of approved wire cutters
- a permanent marker pen

You may need:

- installation accessories such as sleeve, earth sleeve, grommets, grommet strip
- tools to remove and reinstate an existing light fitting

The **single lamp** ReFit T5 kit contains the following items and accessories

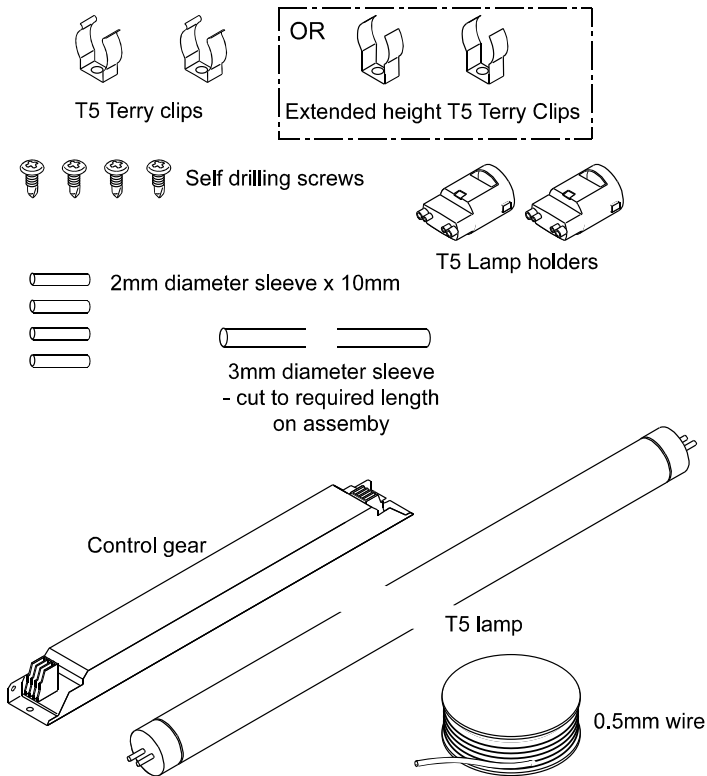

Optional items, if you ordered them, include

- T5 lamps or T5 WattMiser lamps or other energy saving or specialist lamps
- Sleeving (used with some surface fittings where cables may otherwise be exposed)
- Self adhesive ReFit T5 label

3 Twin lamp ReFit T5 kit ▲

The **twin lamp** ReFit T5 kit contains the following items and accessories:

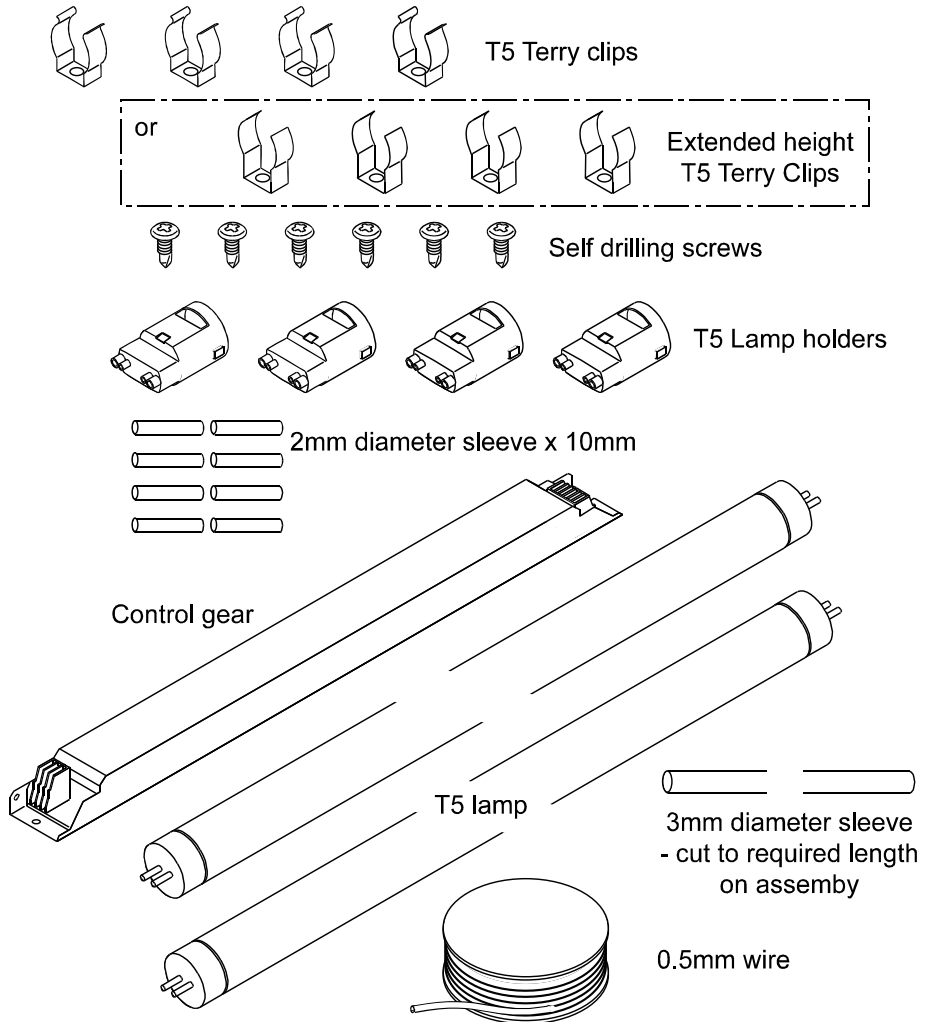

Optional items, if you ordered them, include

- T5 lamps or T5 WattMiser lamps or other energy saving or specialist lamps
- Sleeving (used with some surface fittings where cables may otherwise be exposed)
- Self adhesive ReFit T5 label

4 Preparing the fitting ▲

Isolate the mains supply to existing fitting. Check isolation with an approved voltage indicator. The luminaire can be upgraded in-situ or brought down to a work bench.

A generic single tube luminaire is used for illustration purposes in this document.

- Remove all components and wiring from the luminaire side of the mains connector.
- Set aside components required for re-assembly.

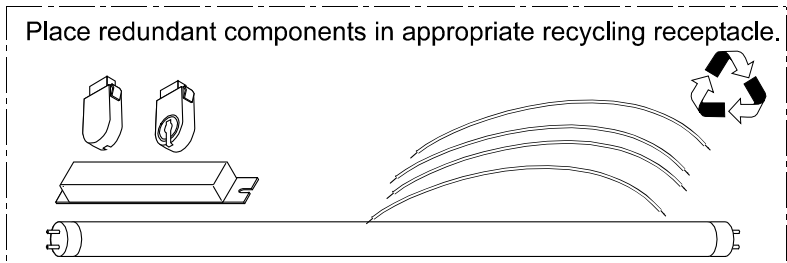
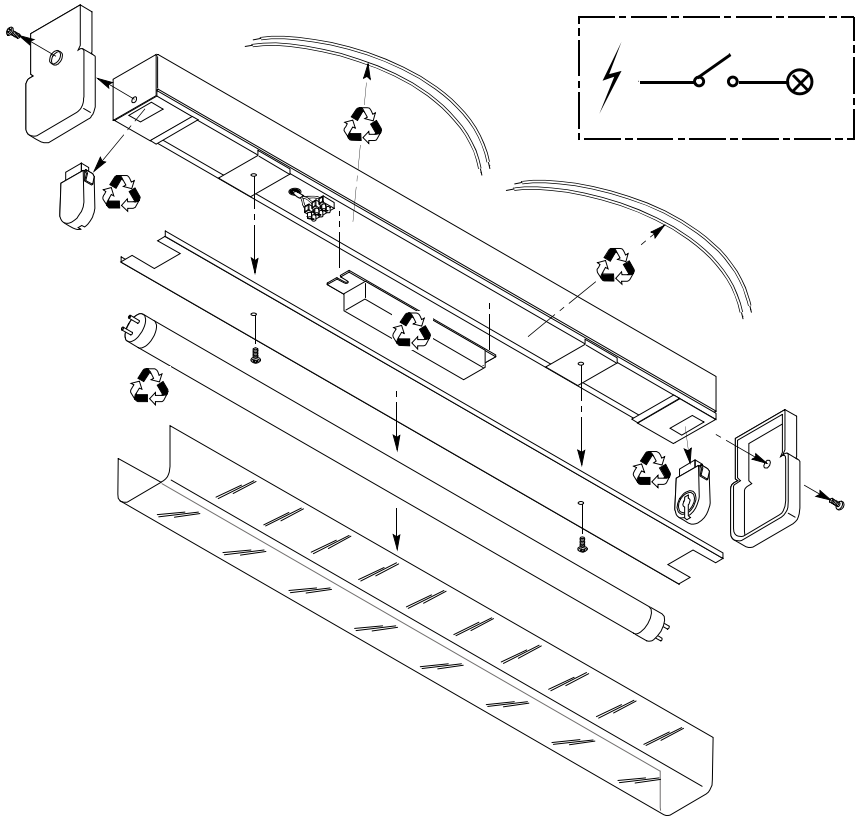

5 Installing the ReFit T5 kit ▲

Fit the electronic control gear to the chassis using the self drilling screws provided.

In some cases, where for example the control gear is positioned on the lid of the fitting, it may be more appropriate to reuse the existing nut and bolt fixings, using one existing hole and making one new hole to suit the length of the electronic control gear.

- Ensure that the location is selected so that the existing luminaire fixing positions, or alternative fixing positions, are not obstructed.
- Position the electronic control gear in a suitable location so that the mains supply terminals of the electronic control gear is close to the mains connector. If the mains connector is unsuitable or damaged then replace it with a suitable terminal with equal or greater clearances in line with EN 60598. It is desirable to minimise the length of cable to the mains terminals and to keep the mains cabling separated from all other wiring. Do not connect mains wiring directly, always use a connector.
- Position the electronic control gear flush on a flat section of the chassis to ensure good contact as the chassis will act as a heat sink.

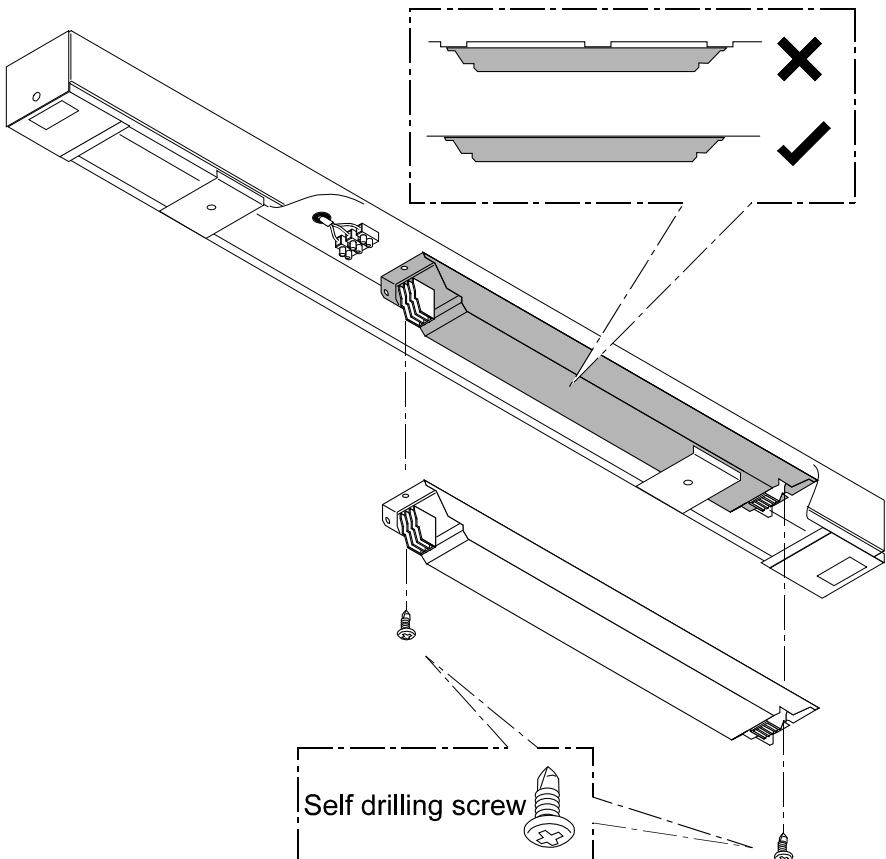

6 Wiring the ReFit T5 kit ▲

- Determine the cable lengths required to connect the electronic control gear to the mains supply terminals - including the earth terminal. Prepare the cables as shown. Provide 3mm earth sleeve for the earth conductor and prepare.
- Determine the cable lengths required to connect the electronic control gear to the lamp holders and cut to size. Some surface fittings, where cables may otherwise be exposed, will need sleeve over the exposed section of the cable. Use the 2mm strip to anchor the end of the 3mm sleeve. Prepare the cables and sleeve as shown.
- Refer to the wiring diagram printed on the electronic control gear and ensure that the maximum cable length specified is not exceeded. Wiring diagrams can differ for each make and model of control gear and examples are provided on page 16.

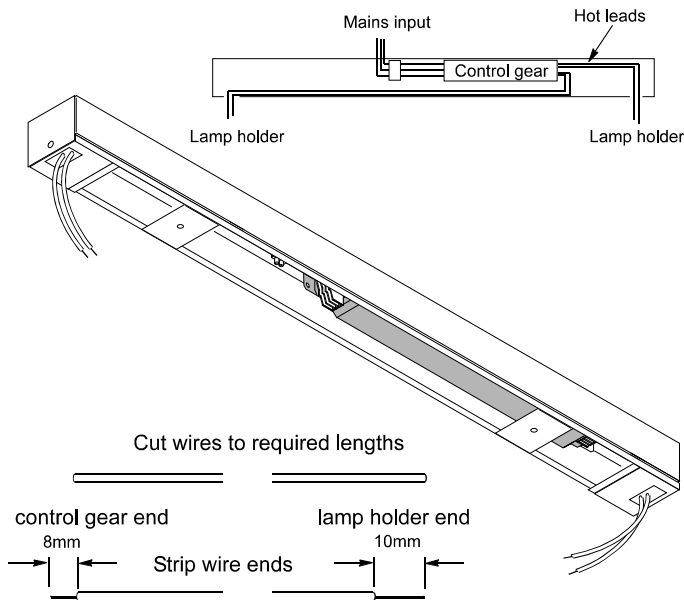

Cut 3mm diameter sleeve to required length to protect wire run through holes and slide onto wire.

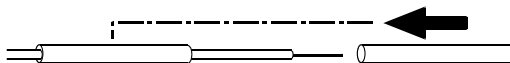

Push 2mm sleeve onto wire flush to stripped edge as shown.



7 Prepare for connecting the ReFit T5 kit ▲

Prepare the fitting before connecting the ReFit T5 kit.

- If any cables pass through holes within the fitting, for example where redundant lamp holders have been removed, ensure any sharp metal edges are protected using grommets or grommet strip, in addition to the sleeve that may be applied to the cable.
- If any items have been removed, for example starter holders, ensure any holes are blanked off with a blind grommet or gland to prevent contact. Remove or score through any redundant labels using a permanent marker pen, as the old lamp size, approvals and ratings will no longer apply.
- Now connect the electronic control gear to the mains terminal block. For some models, the electronic control gear is not polarity sensitive, but for other models it is. Check before making the connections to ensure the correct polarity where required. Always connect the earth conductor to the electronic control gear.

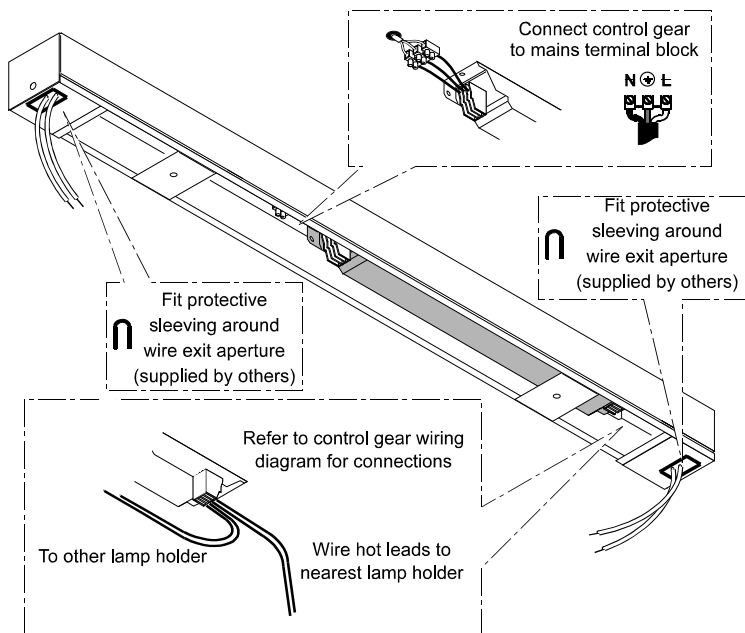

- Now connect the electronic control gear cables for the lamp holders. Refer to the wiring diagrams and ensure that the maximum cable length specified is not exceeded. Wiring diagrams can differ for each make and model of control gear.
- Only use the cable supplied which must be solid conductors with diameter of between 0.5mm^2 and 1.5mm^2 . Leave cables tidily contained within the fitting.

8 Attaching the T5 Terry clips ▲

Two T5 Terry clips are used to support each T5 lamp, independently of the lamp holders. These need positioning to support lamps symmetrically, 100mm from each lamp holder.

Before attaching the T5 terry clips with the self drilling screws as shown, first check the proposed position for the clips. Ensure that the screws will not cause any contact with other parts or cabling within the fitting when reassembled. If there is any potential for contact, adjust the positioning of the clips to an alternative location. Ensure that the new location is also suitable and adequate to support the lamp. Remember the new location may need to be checked to ensure any louvers will also clear the lamps on reassembly.

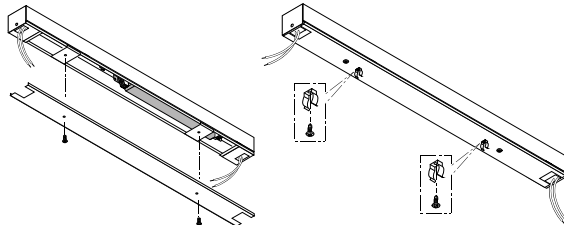

In some cases, the cover plate of the fitting will have thumb wheels or large round head screws to secure the cover plate to the chassis. Check the depth of the thumb wheels or screws. It is important that they will not clash with the T5 lamp when it is fitted. This can be avoided by adjusting the T5 Terry clip position, or by selecting the extended height T5 Terry clips which provide extra clearance between the cover plate and the lamp.

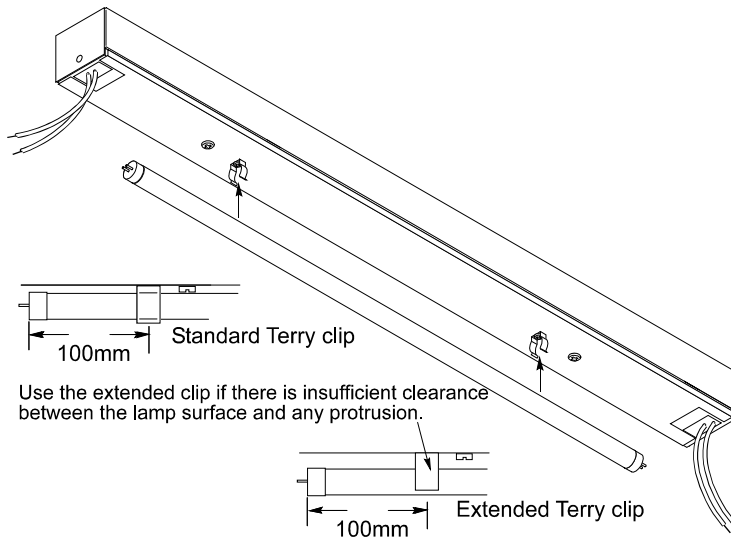

In some cases, additional spacers and longer screws may need to be sourced by the installer where clearances are inadequate when using the standard parts. If there is a louver that will be attached, it may be preferable to adjust the position of the clips so that the clips are concealed by the louver when the fitting is reassembled.

9 Prepare for the lamp holders ▲

The lamp holder wiring will normally pass through the channel where the redundant lamp holders were positioned. In some cases, where for example the lamp holder is part of the fitting end cap, it is possible to unclip the rotating lamp holder assembly from the end cap moulding and use the remaining channel for the cable to pass through.

There may be some fittings where it is necessary to pass the lamp holder cables through a new channel.

When preparing a new channel for the lamp holder cables to pass through, the preferred method is to make a suitable opening, either semi circular or a slot, at the end of the cover plate. This method prevents the opening from surrounding the cables which means that the cover plate can still be removed freely for future servicing of the electronic control gear.

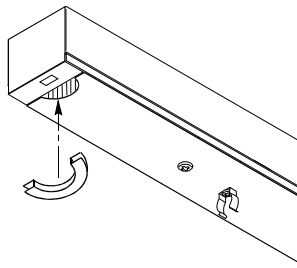

If a circular hole needs to be drilled through the cover plate, for example due to the construction of the fitting, or in the middle of a 6' or 8' fitting (where lamp holders will be wired centrally in the fitting to enable 2 shorter lamps to be fitted end to end), ensure that the hole is large enough for the lamp holder to pass through so that the plate can still be removed in the future for servicing.

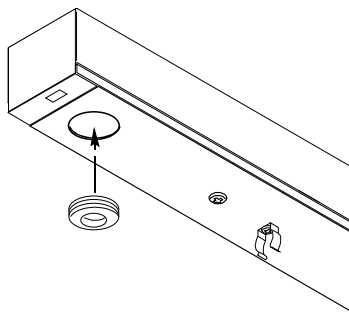

Remember to securely fit grommet strip or a grommet to the hole or channel.

10 Connecting the lamp holders

Now connect the lamp holders as shown below. The sleeve shown is only required where cables are exposed.

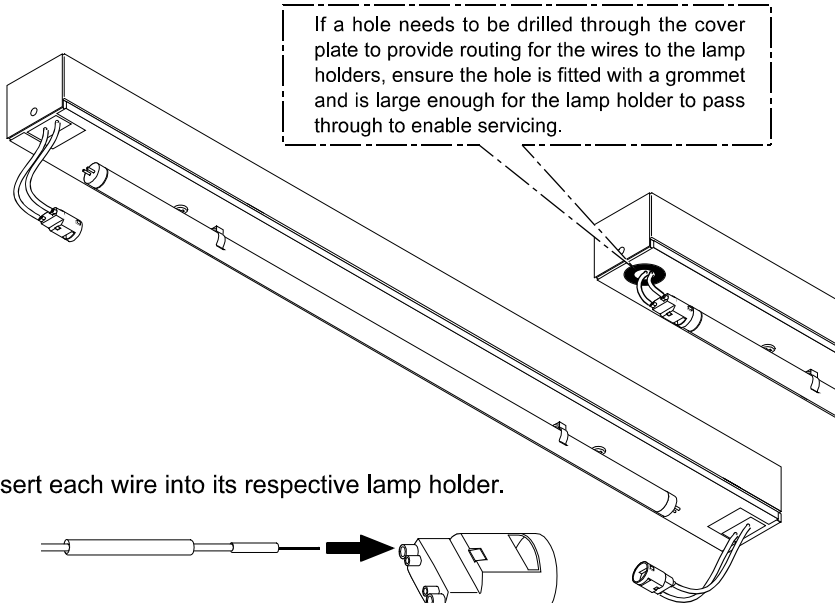

Insert each wire into its respective lamp holder.

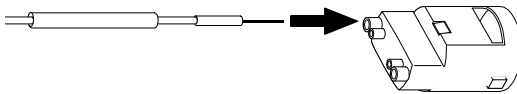

Slide the 3mm sleeve over the 2mm sleeve to the lamp holder surface.

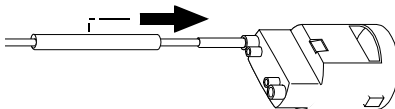

Push on T5 lamp holders to each end of lamp.

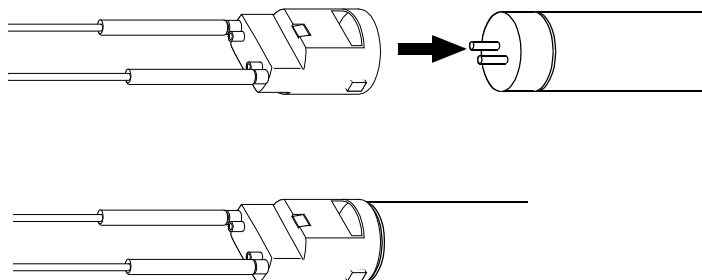

11 Final assembly ▲

Now the plate is carrying the weight of the lamp and accessories, if the plate does not have a mechanical fixing then extra security may be required. Use suitable tie wraps, zip lock system or a mechanical fixing accessory to provide extra security for the plate.

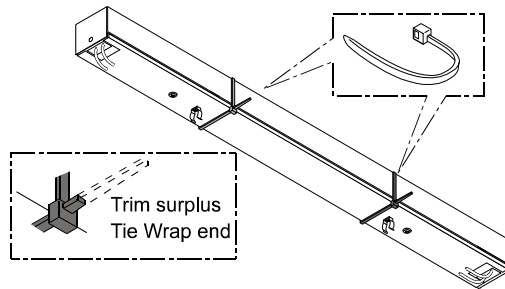

Secure the lamp in to the clips and ensure any exposed cable is left neatly without any strain and clear of any fixings for the diffuser or louver. Remember that some diffuser fixings may need to be attached before inserting the lamp in to the clips.

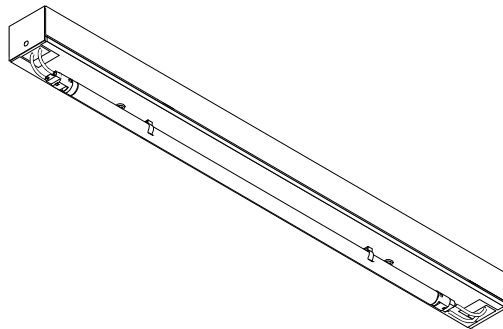

Attach any remaining accessories, ensuring any louvers or diffusers are clean and that any marks applied during the installation are removed from reflectors and lenses.

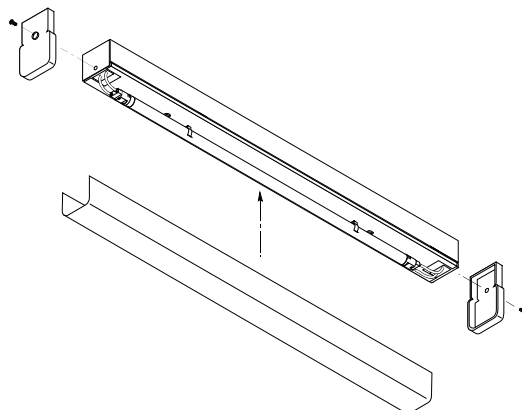

12 Testing ▲

Reinstate the supply and check operation.

The starting current of an electronic control gear is higher than the operating current so it is important that surge current resistant, short delay RCDs are used and the maximum number of fittings is not exceeded.

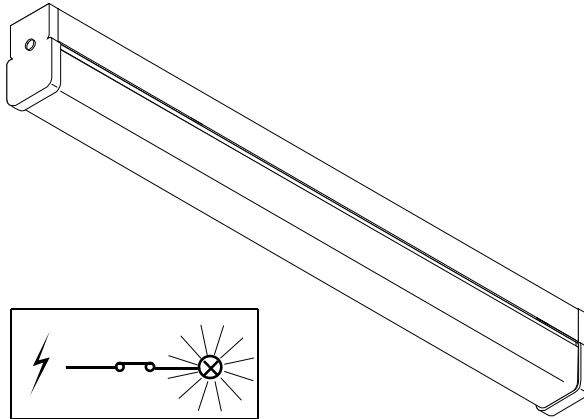

Once completed, a label is to be attached to the outside of the modified fitting. The label needs to be marked using a permanent marker to identify the installer, the date the work was completed. The quantity of lamps within the fitting and the lamp rating should be identified by ticking the appropriate boxes on the label.

ReFit T5 Chalmer 01582 785700 www.dba.mor.co.uk	Lamp quantity	<input checked="" type="checkbox"/>	Lamp	<input checked="" type="checkbox"/>	Lamp	<input checked="" type="checkbox"/>
	Installer:	1	14W	49W		
		2	21W	80W		
	Date:	3	28W			
		4	35W			

The label should be attached so that it is visible when the lamp is being replaced. For consistency, it is recommended that (unless the part is removable when servicing work is undertaken) the label be applied to the end of the fitting adjacent to the lamp holder or diffuser end cap.

13 Technical properties ▲

Technical information varies by brand and model of control gear and lamps.

Please request any technical information for the brand and model of control gear required from Chalmer.

14 Wiring diagrams ▲

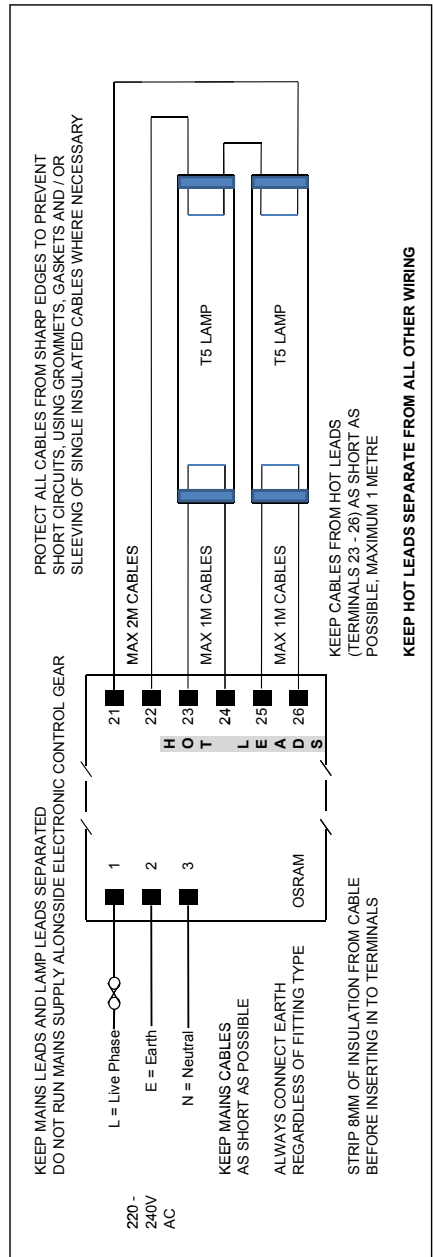
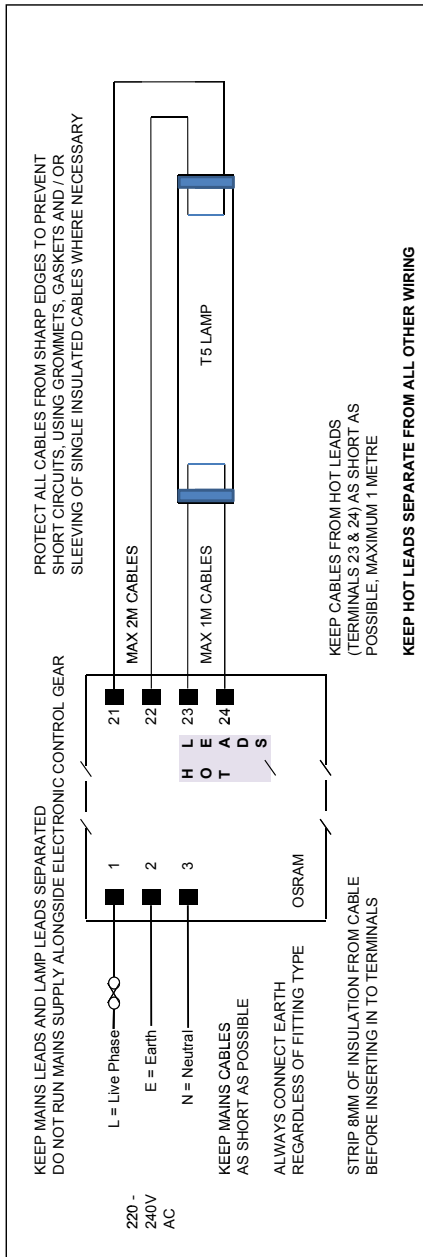

Wiring diagrams are printed on the plate of each control gear. Please refer to the wiring diagram paying particular attention to the polarity of the mains supply, and the hot wires for the lamp connections. Example diagrams are provided above, but may not be identical to the model of control gear being installed. Please check before making any connections. Larger print wiring diagrams and record drawings are available on request.