

LIGHT ENGINE VIOLET UVC 281mm x 19.2mm 560mW + Red Alert Light

Applications

- Medical sterilization
- Drinking water disinfection
- Infectious disease control
- Food processing sterilization
- Air sterilization

Characteristics

- UV Type - UVC
- Wavelength – 260-270nm
- 05 years warranty against factor defects

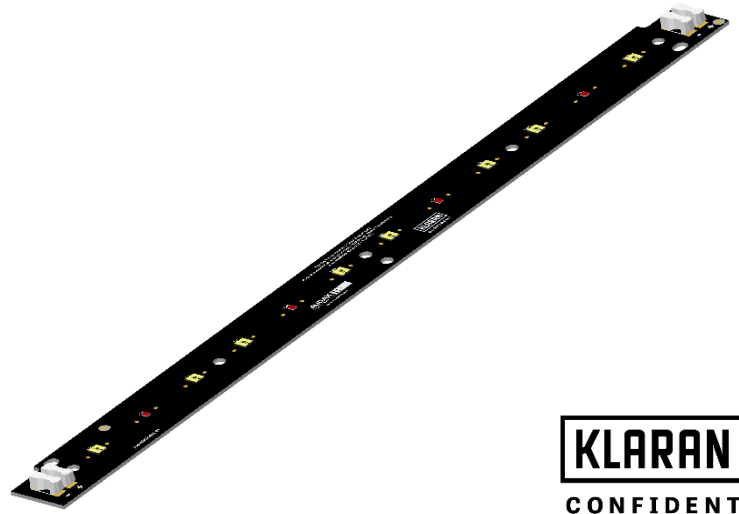

DRIVING CURRENTS

Parameter	Nominal	Max
LIGHT ENGINE VIOLET UVC 281mm x 19.2mm 642mW	1,000 mA	1,200 mA

MODULE TEMPERATURES

Parameter	Nominal	Max
Tc (temperature at Tc point)	40 °C	60 °C

PRODUCT PART NUMBER

AUD002-08
UVC – 260-270 nm

TECHNICAL INFORMATION

UV Type	Wavelength (nm)	#LEDs	Forward Current (mA)	Rad. Power (mW)	Forward Voltage (V)	Power (W)	Ts (°C)	EFF (%)
UVC	260-270	8 UVC + 4 RED	700	448	36.0	25.2	40	1.8
			1,000	560	38.0	38.0	40	1.5
			1,200	592	45.0	54.0	40	1.1

LED TYPE

Manufacturer: Crystal IS, Klaran

LED Series: KL265

Rad. Power (mW) x Forward Current (mA) (Tj 75°C)

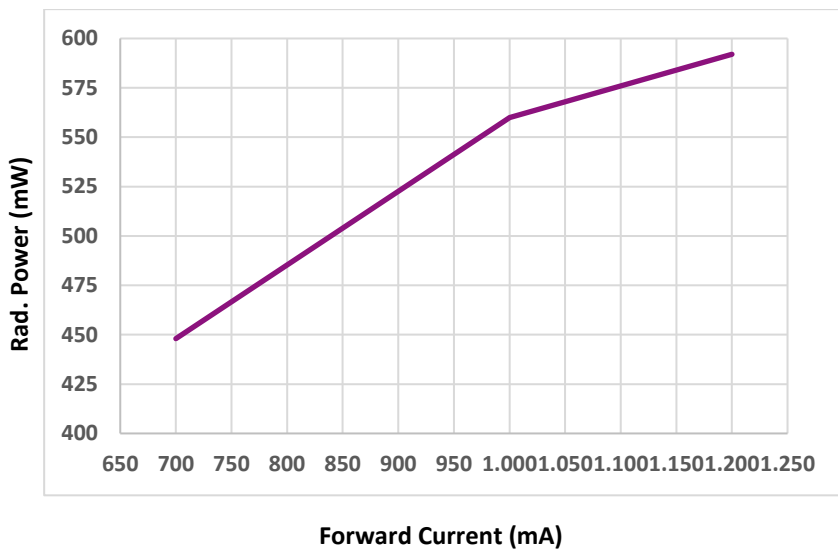

Forward Voltage (V) x Forward Current (mA) (Tj 75°C)

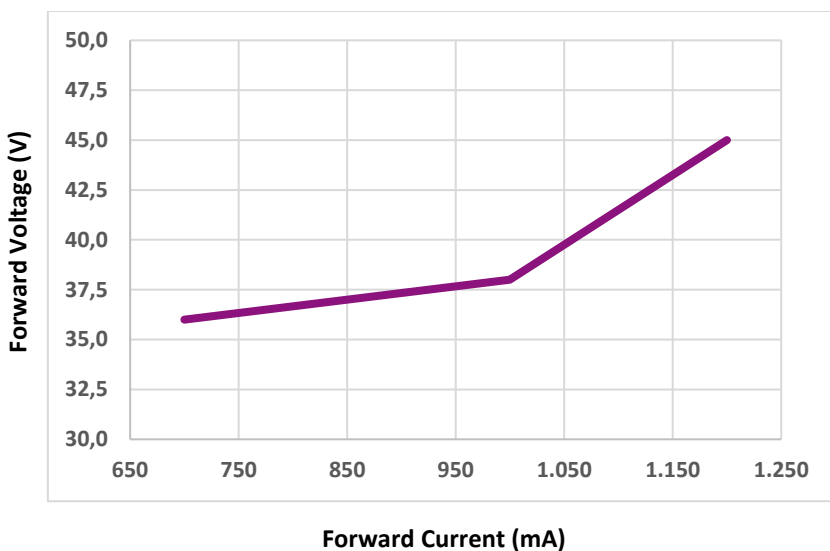

SCHEMATICS

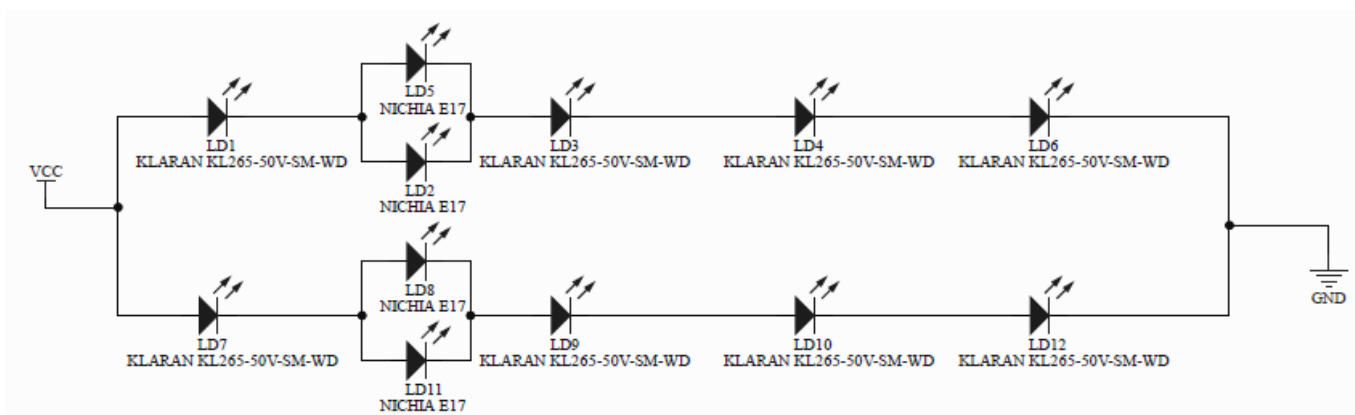

MECHANICAL DRAWING

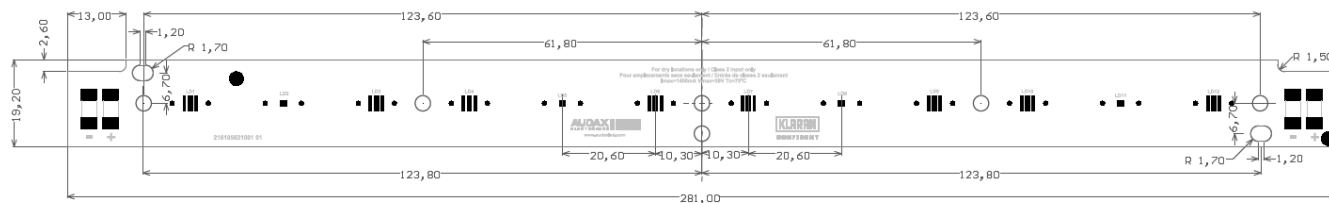

WIRING

Unit: mm

Specification item	Value	Unit	Condition
Input wire cross- section	0.25...0.75 18...24	mm ² AWG	Solid wire
Input wire strip length	7.5...8.5	mm	Solid wire
Input wire cross-section	0.33...0.5 20...22	mm ² AWG	Stranded wire
Input wire strip length	7.5...8.5	mm	Stranded wire

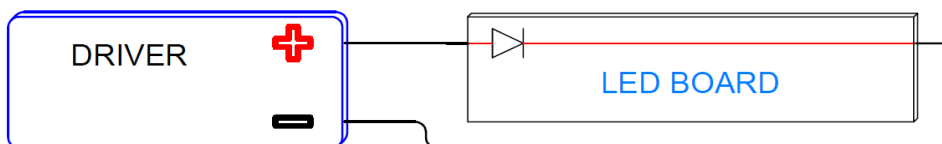

WARNING

