

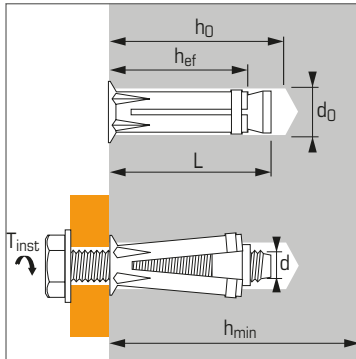

Universal female anchor for use in concrete and masonries



Technical data

Anchor size	Min. anchor depth (mm) hef	Thread diameter (mm) d	Drilling depth (mm) h₀	Drilling diameter (mm) d₀	Min. thick. of base material (mm) h_{min}	Total anchor length (mm) L	Tighten torque		Code
							plein (Nm) T_{inst}	creux (Nm) T_{inst}	
M6X40	35	6	50	10	85	42	8	5	053100
M8X45	40	8	55	12	95	47	15	10	053110
M10X55	45	10	60	15	105	53	30	20	053120
M12X70	58	12	75	18	140	68	50	22	053130
M6X40 + TH 6X50									053150
M6X40 + QDC A2									053170
M8X45 + TH 8X55									053200
M12X70 + QDC GAL									053140

APPLICATION

- Fixing on hollow or solid materials
- Steel cupboards
- Overhead fixings

MATERIAL

- **Sleeve** : lead alloy
- **Cone** : S300Pb

INSTALLATION

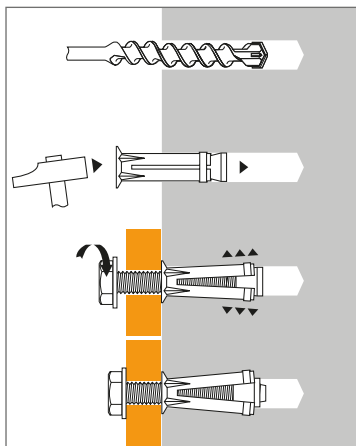

Bending moments

Anchor size	M6	M8	M10	M12
Screw grade 6.8				
Recommended bending moment (Nm)	2,5	6,0	12,5	22

Ultimate loads ($N_{Ru,m}$, $V_{Ru,m}$) in kN

TENSILE

Anchor size	M6	M8	M10	M12	M6 QDC	M12 QDC
Concrete (C20/25)						
$N_{Ru,m}$	4,8	11,4	16,5	28,5	1,5	24,0
Concrete (C30/37)						
$N_{Ru,m}$	5,4	15,6	20,1	35,4	1,5	24,0
Solid concrete blocks B 120 ($f_c = 13,5$ MPa)						
$N_{Ru,m}$	2,4	5,7	7,5	11,4	1,5	11,4
Solid clay bricks ($f_c = 55$ MPa)						
$N_{Ru,m}$	4,2	11,4	14,4	24,6	1,5	24,0
Hollow concrete blocks B40 not rendered ($f_c = 6,5$ MPa)						
$N_{Ru,m}$	1,8	1,8	1,8	1,8	1,8	1,8
Hollow clay bricks eco-30 not rendered ($f_c = 4,5$ MPa)						
$N_{Ru,m}$	1,1	1,3	1,75	2,2	1,1	2,2

SHEAR

Anchor size	M6	M8	M10	M12
Concrete (C20/25)				
$V_{Ru,m}$	3,6	12,6	18,6	30,6
Concrete (C30/37)				
$V_{Ru,m}$	3,6	12,6	18,6	30,6
Solid concrete blocks B 120 ($f_c = 13,5$ MPa)				
$V_{Ru,m}$	3,0	10,5	13,2	18,9
Solid clay bricks ($f_c = 55$ MPa)				
$V_{Ru,m}$	3,3	11,4	18,0	24,0
Hollow concrete blocks B40 not rendered ($f_c = 6,5$ MPa)				
$V_{Ru,m}$	4,45	5,65	6,55	6,85
Hollow clay bricks eco-30 not rendered ($f_c = 4,5$ MPa)				
$V_{Ru,m}$	4,2	5,05	6,75	9,55



Design loads (N_{Rd} , V_{Rd}) for one anchor without edge or spacing influence in kN

$$N_{Rd} = \frac{N_{Rum}^*}{4,3}$$

*Derived from test results

$$V_{Rd} = \frac{V_{Rum}^*}{4,3}$$

TENSILE

Base material	Anchor size	M6	M8	M10	M12	M6 QDC	M12 QDC
Concrete (C20/25)							
N_{Rd}		1,12	2,66	3,85	6,85	0,84	5,60
Concrete (C30/37)							
N_{Rd}		1,26	3,64	4,69	8,26	0,84	5,60
Solid concrete blocks B 120 ($f_c = 13,5$ MPa)							
N_{Rd}		0,56	1,33	1,75	2,66	0,84	5,60
Solid clay bricks ($f_c = 55$ MPa)							
N_{Rd}		0,98	2,66	3,36	5,74	0,56	2,66
Hollow concrete blocks B40 not rendered ($f_c = 6,5$ MPa)							
N_{Rd}		0,42	0,42	0,42	0,42	0,42	0,42
Hollow clay bricks eco-30 not rendered ($f_c = 4,5$ MPa)							
N_{Rd}		0,26	0,30	0,41	0,51	0,26	0,51

SHEAR

Base material	Anchor size	M6	M8	M10	M12
Concrete (C20/25)					
V_{Rd}		0,84	2,94	4,34	7,14
Concrete (C30/37)					
V_{Rd}		0,84	2,94	4,34	7,14
Solid concrete blocks B 120 ($f_c = 13,5$ MPa)					
V_{Rd}		0,70	2,45	3,08	4,41
Solid clay bricks ($f_c = 55$ MPa)					
V_{Rd}		0,77	2,66	4,2	5,60
Hollow concrete blocks B40 not rendered ($f_c = 6,5$ MPa)					
V_{Rd}		1,04	1,32	1,53	1,60
Hollow clay bricks eco-30 not rendered ($f_c = 4,5$ MPa)					
V_{Rd}		0,98	1,18	1,58	2,23

Recommended loads (N_{rec} , V_{rec}) for one anchor without edge or spacing influence in kN

$$N_{rec} = \frac{N_{Rum}^*}{6}$$

*Derived from test results

$$V_{rec} = \frac{V_{Rum}^*}{6}$$

TENSILE

Base material	Anchor size	M6	M8	M10	M12	M6 QDC	M12 QDC
Concrete (C20/25)							
N_{rec}		0,80	1,90	2,75	4,75	0,60	4,00
Concrete (C30/37)							
N_{rec}		0,90	2,60	3,35	5,90	0,60	4,00
Solid concrete blocks B 120 ($f_c = 13,5$ MPa)							
N_{rec}		0,40	0,95	1,25	1,90	0,60	4,00
Solid clay bricks ($f_c = 55$ MPa)							
N_{rec}		0,70	1,90	2,40	4,10	0,40	1,90
Hollow concrete blocks B40 not rendered ($f_c = 6,5$ MPa)							
N_{rec}		0,30	0,30	0,30	0,30	0,30	0,30
Hollow clay bricks eco-30 not rendered ($f_c = 4,5$ MPa)							
N_{rec}		0,18	0,22	0,29	0,37	0,18	0,37

SHEAR

Base material	Anchor size	M6	M8	M10	M12
Concrete (C20/25)					
V_{rec}		0,60	2,10	3,10	5,10
Concrete (C30/37)					
V_{rec}		0,60	2,10	3,10	5,10
Solid concrete blocks B 120 ($f_c = 13,5$ MPa)					
V_{rec}		0,50	1,75	2,20	3,15
Solid clay bricks ($f_c = 55$ MPa)					
V_{rec}		0,55	1,90	3,00	4,00
Hollow concrete blocks B40 not rendered ($f_c = 6,5$ MPa)					
V_{rec}		0,74	0,94	1,09	1,14
Hollow clay bricks eco-30 not rendered ($f_c = 4,5$ MPa)					
V_{rec}		0,70	0,84	1,13	1,59

Spacing data

IN CONCRETE AND SOLID MASONRIES

Anchor size	Minimum distance between anchors and from edges (mm)		
	$S_{cr,1}$ mini without edge influence	$C_{cr,N}$ mini	$C_{cr,V}$ mini
M6	90	70	70
M8	100	80	80
M10	115	90	90
M12	150	115	115