



INSTRUCTION DE MONTAGE  
MONTAGEANLEITUNG  
INSTRUCTIONS FOR ASSEMBLY  
INSTRUCCIONES DE MONTAJE

# SAF-INSIDE

## NM SI80

*PORTE ENTRE-CLOISONS: 1 PORTE MANUELLE*  
*KASTENRAHMENSYSTEM FÜR SCHIEBETÜR : 1 HANDTÜR*  
*POCKETDOOR – 1 MANUAL DOOR*  
*PUERTA ENTRE TABIQUE : 1 HOJA MANUAL*

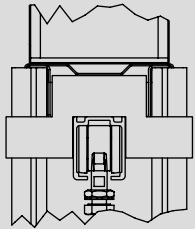

*DEPLACEMENT MANUEL*  
*ANTRIEB: MANUELL*  
*MANUAL MOVE*  
*MOVIMIENTO MANUAL*

Poids maximal des panneaux  
Maximales Gewicht  
Maximum weight  
Peso máximo por hoja

**80 Kg**

Epaisseur des panneaux  
Ladendicke  
Shutter thickness  
Espesor de las hojas

**40 mm**



# COMPOSITION - ZUSAMMENSETZUNG - COMPOSICIÓN

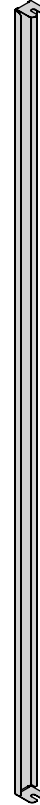
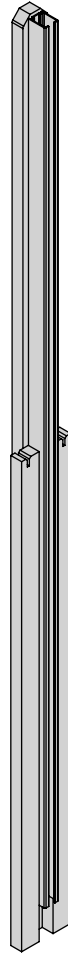
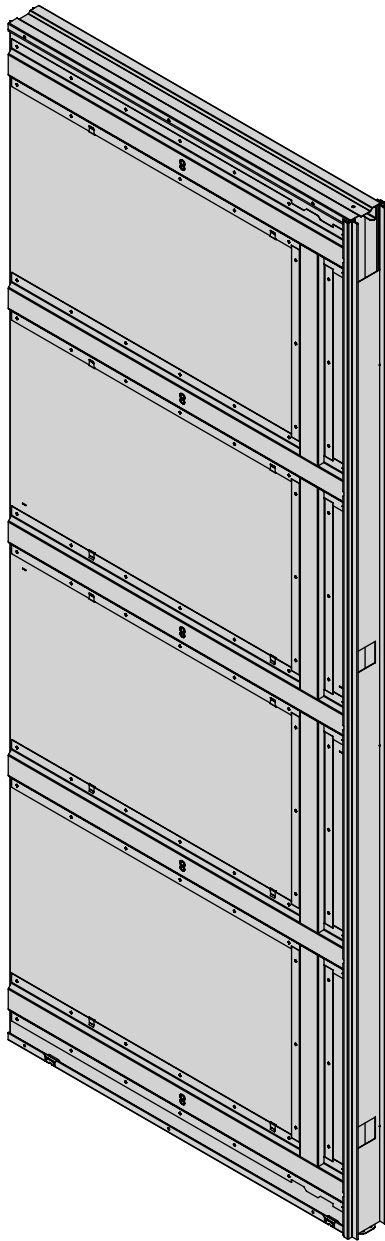

**x2**

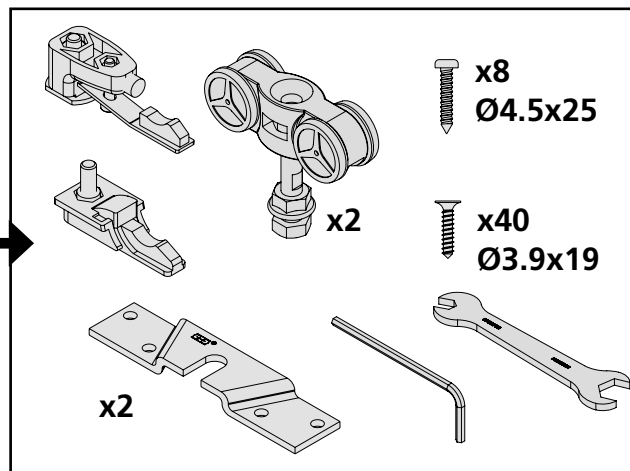
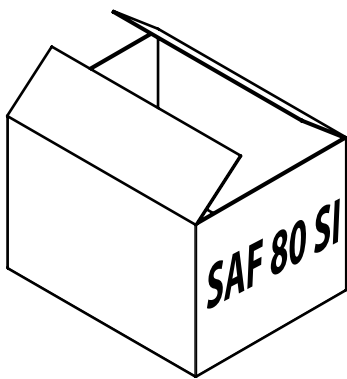

**+**

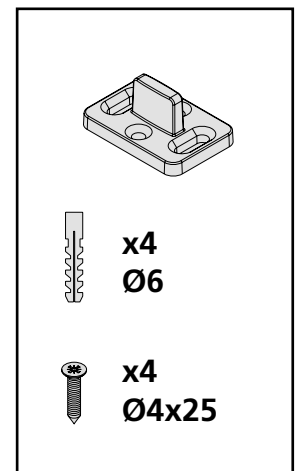

**ENCOMBREMENT / ABMESSUNGEN  
DIMENSIONS / VOLUMEN**

Ref. / Art.Nr Item Nr	LT (mm)	LO (mm) Min / Max
SAF-INSIDE 70	1510	695
SAF-INSIDE 80	1710	795
SAF-INSIDE 90	1910	895
SAF-INSIDE 100	2110	995

dimensions des portes Abmessungen von Türen dimensions of doors Dimensiones de las puertas	
L (mm) Min / Max	W (mm)
730	2040
830	2040
930	2040
1030	2040

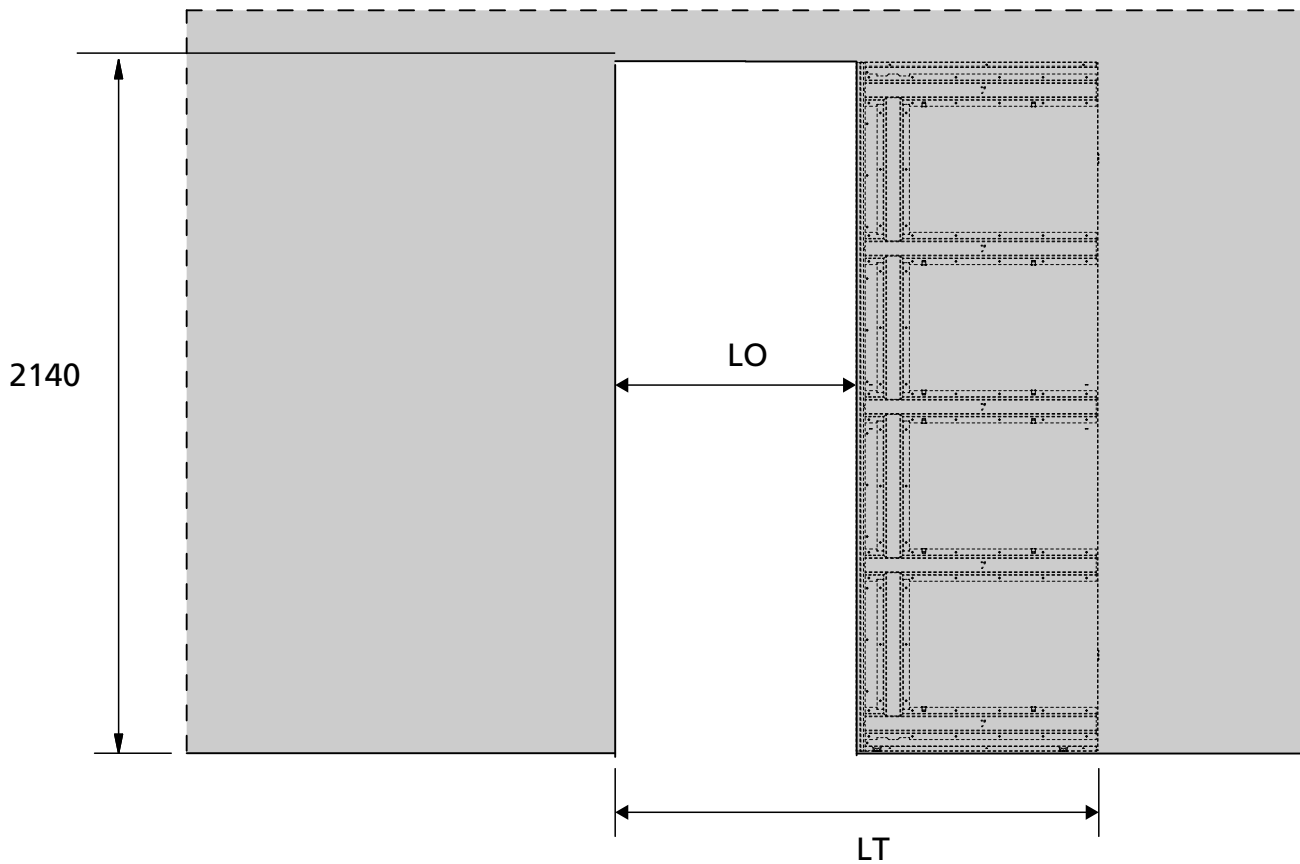
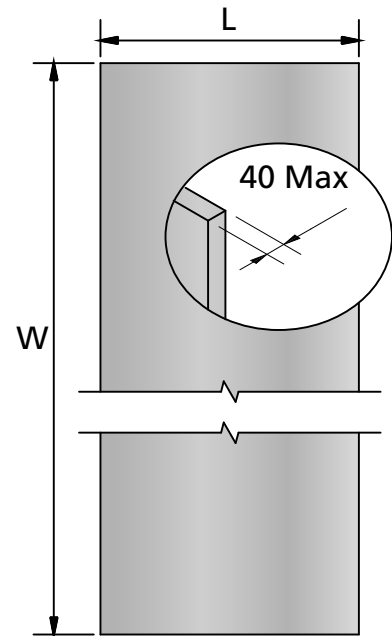

**IMPORTANT:** Produit destiné à une utilisation en intérieur. Ne pas installer dans des endroits humides.  
**WICHTIG:** Dieses Produkt ist nur für Innenanwendung geeignet.  
 Nicht in feuchten Atmosphären verwenden  
**WARNING:** For indoor use only. Do not install in humid places  
**IMPORTANTE:** Producto con destinación en el interior. No instalar en lugares húmedos



**IMPORTANT:** Si la butée n'est pas mise en place à cette étape, il ne sera pas possible de la fixer par la suite.  
**WICHTIG:** Der Endwinkel muss unbedingt in diesem Augenblick befestigen, es wird ganz nicht möglich später sein.  
**WARNING:** The stop must be set at this moment because it will not be possible later.  
**IMPORTANTE:** Si no se ha montado el tope ahora, será imposible colocarlo luego

1.

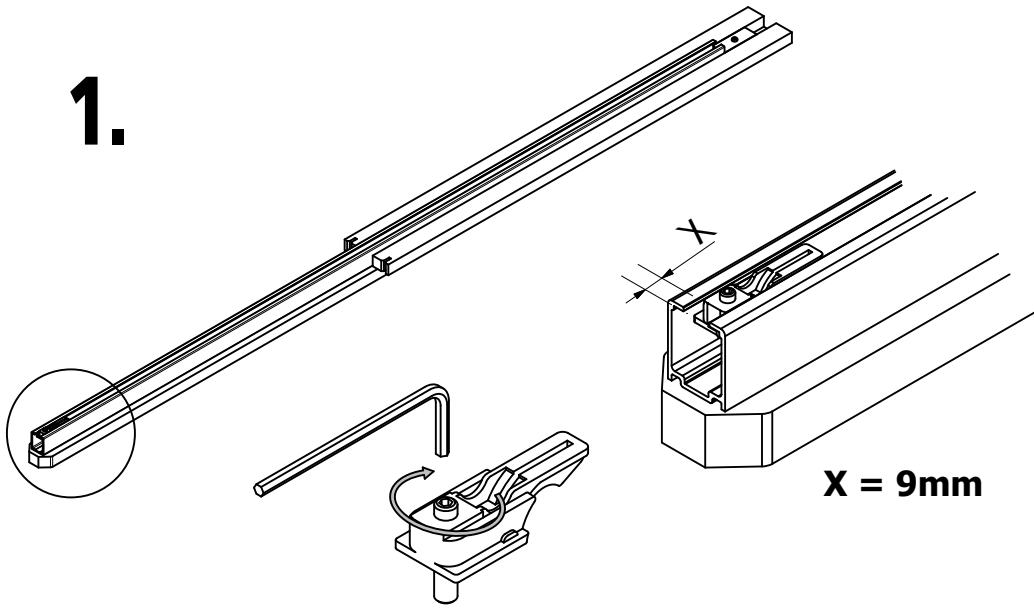

$X = 9\text{mm}$

Si / If / Ob / Si

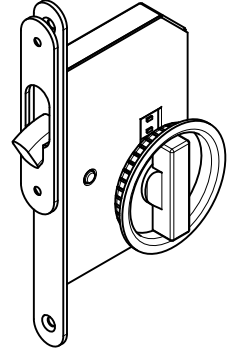

$X = 80\text{mm}$

2.

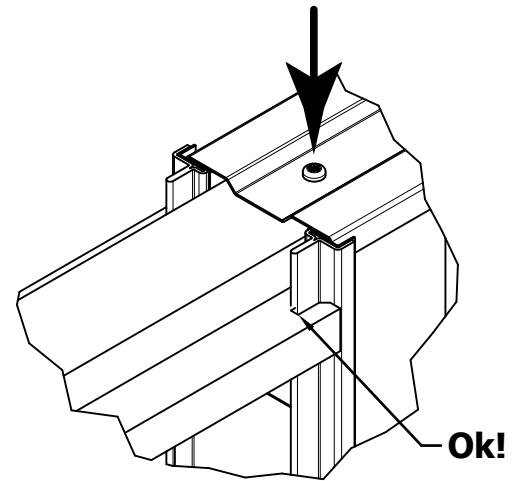
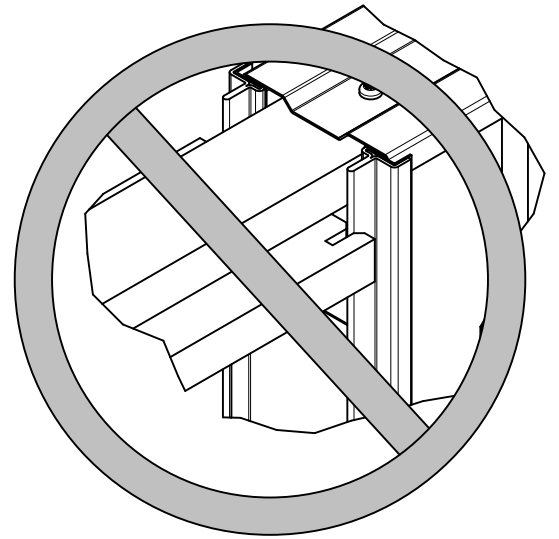
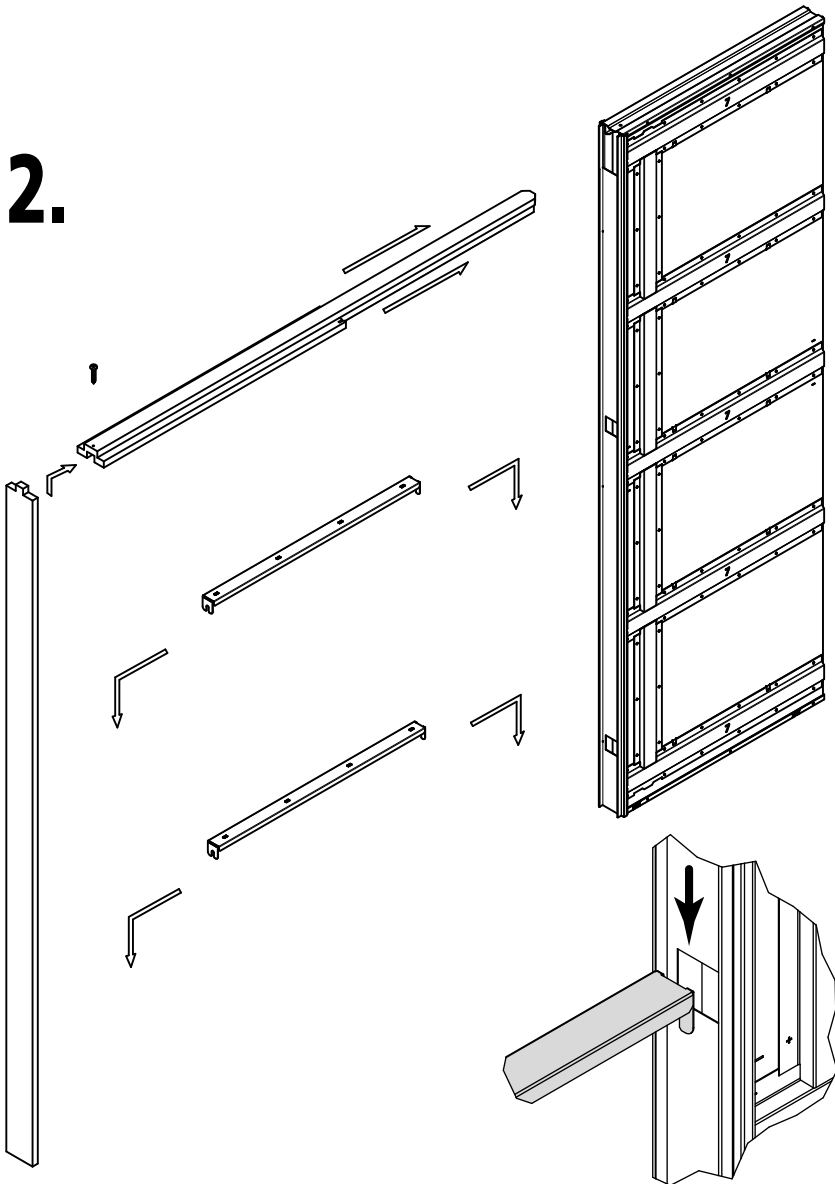

# 3.

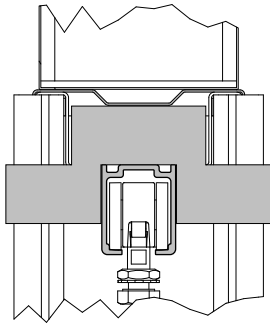

Accessoires de fixation non fournis  
 Fixing accessories not supplied  
 Befestigungszubehör nicht geliefert  
 Accesorios de fijación no suministrados

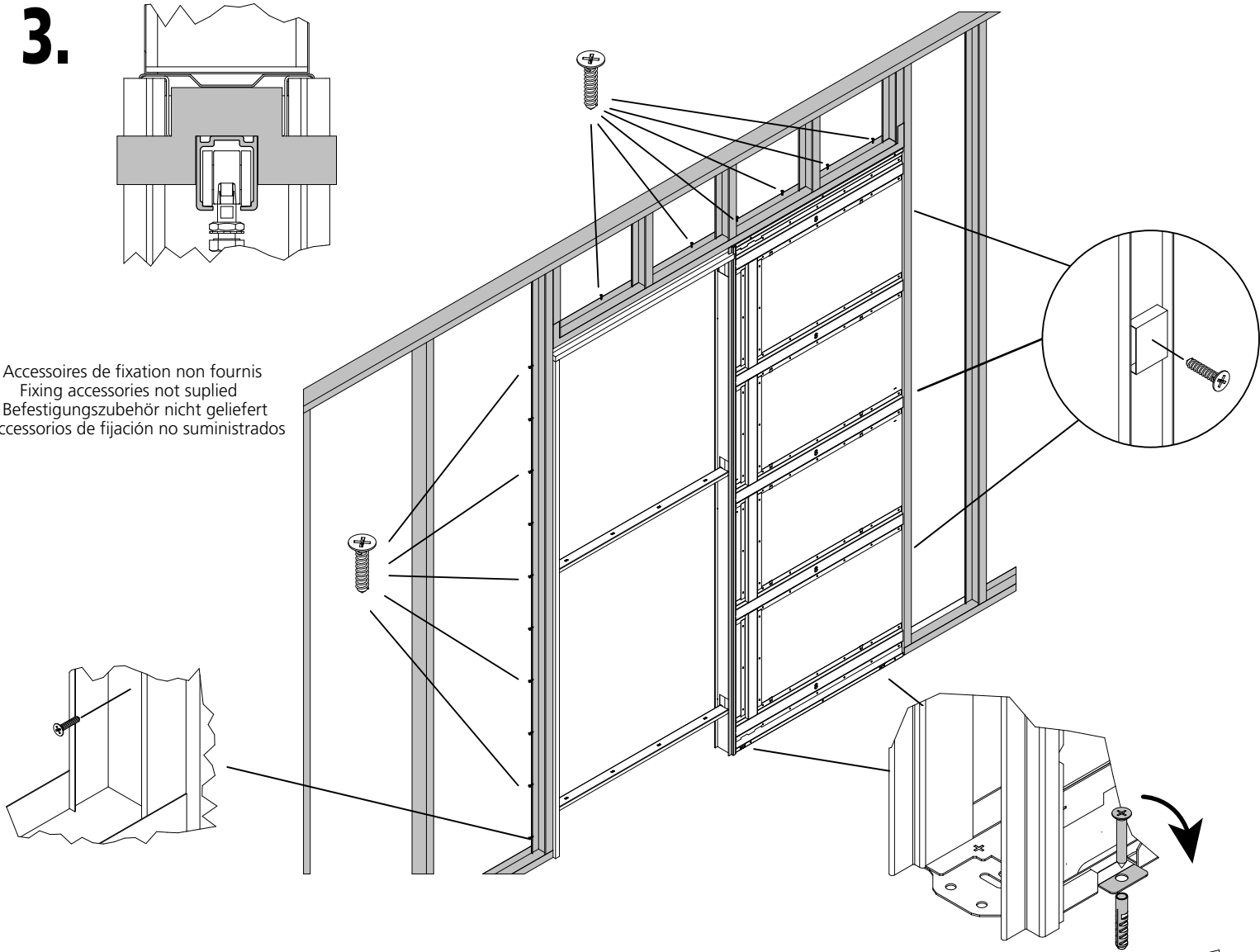

# 4.

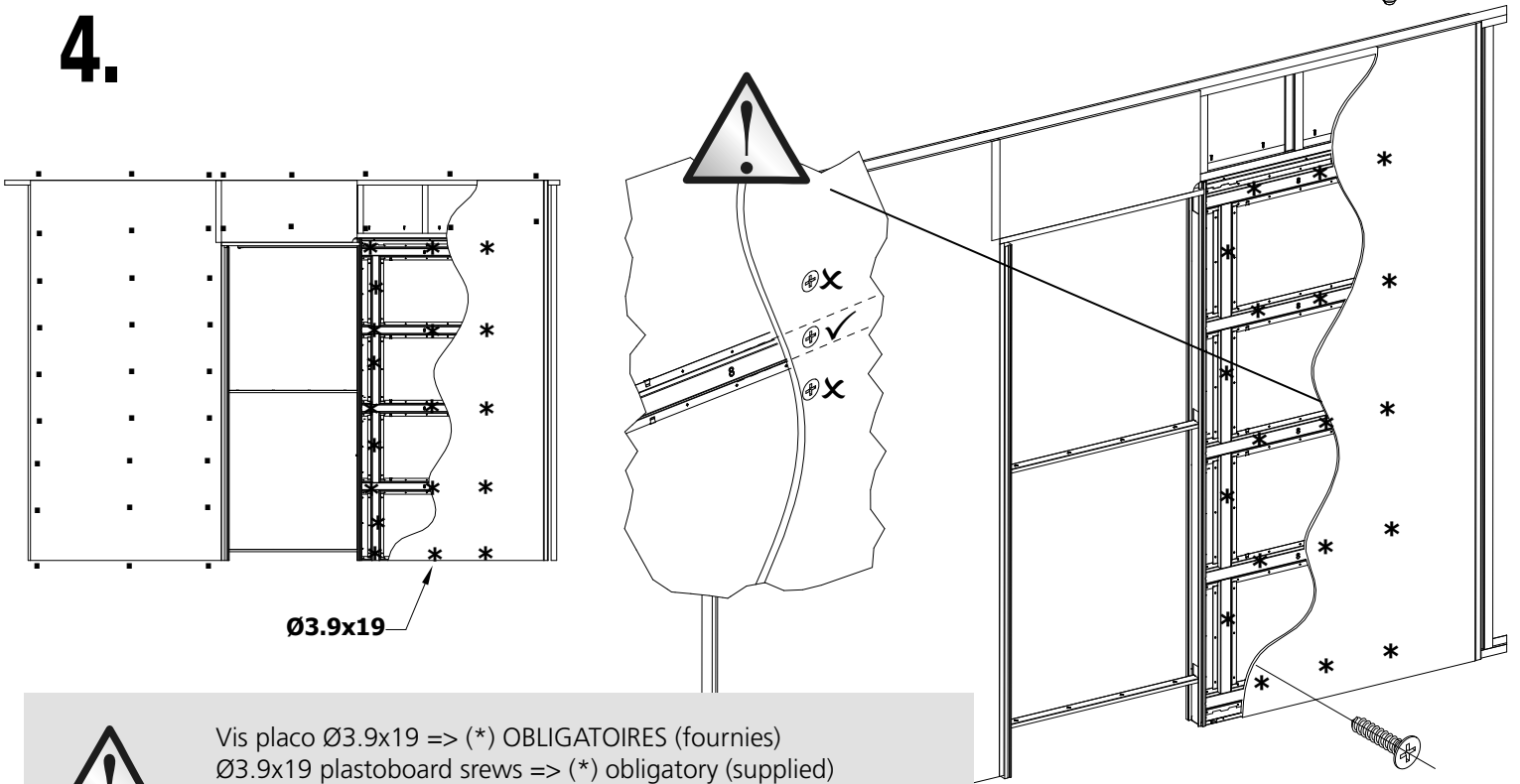

Ø3.9x19

**x40**



Vis placo Ø3.9x19 => (\*) OBLIGATOIRES (fournies)  
 Ø3.9x19 plastoboard screws => (\*) obligatory (supplied)  
 Ø3.9x19 GSP Schrauben Bindend (geliefert)  
 Tornillo para pladur Ø3.9x19 => (\*) IMPERATIVO (suministrados)

# 5.



**IMPORTANT:** Retirer intégralement les cales collées à l'intérieur du caisson.

**WICHTIG:** Take back all the wedges fixed inside the frame.

**WARNING:** Anheben die ganze beklebt Keile in dem Rahmen.

**IMPORTANTE:** Quitar integralmente los calces pegados en el interior del cajón.

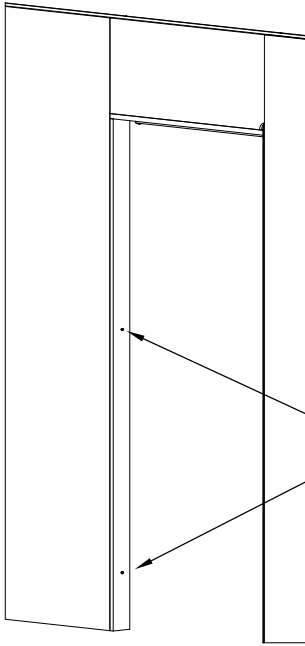

Retirer vis/  
Take back screws/  
Schrauben anheben/  
Quitar los tornillos

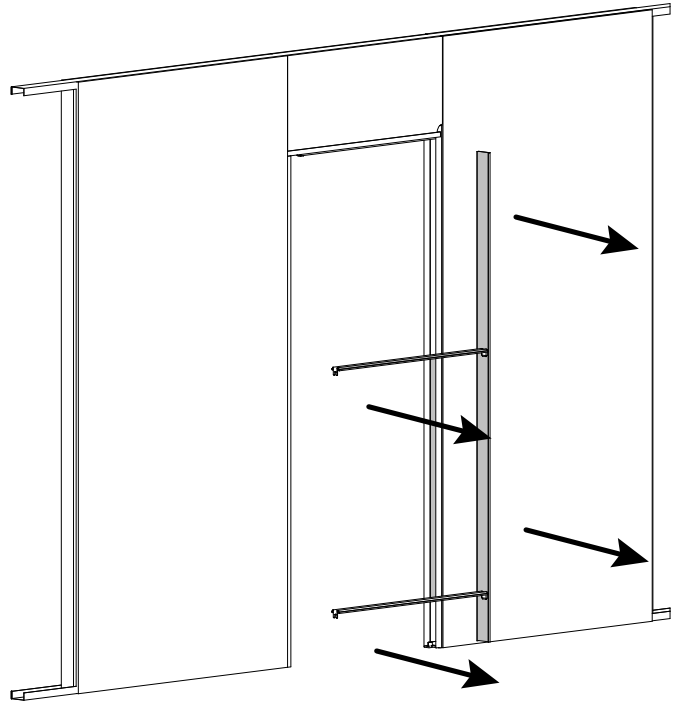

# 6.

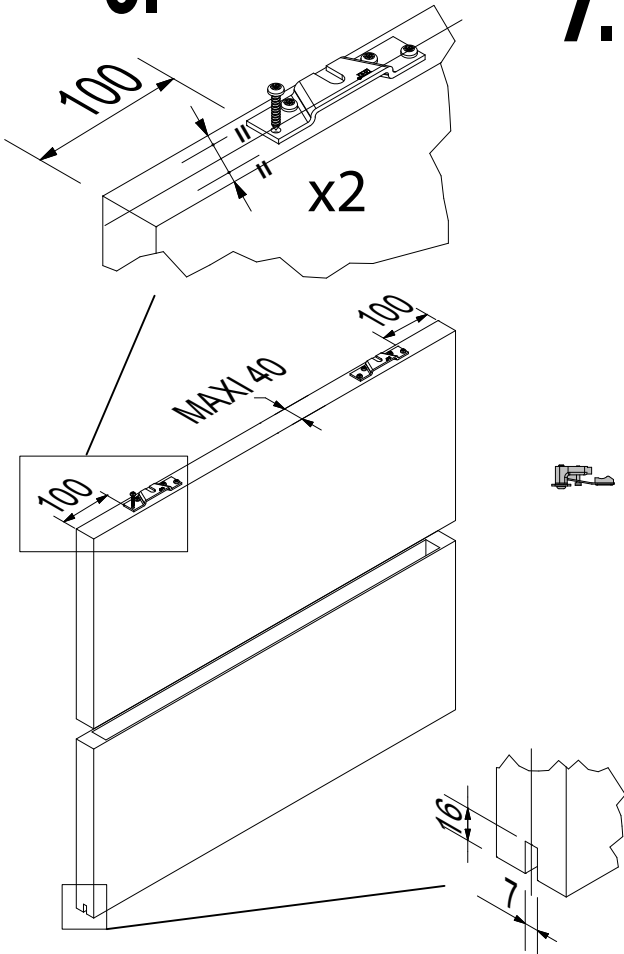

# 7.

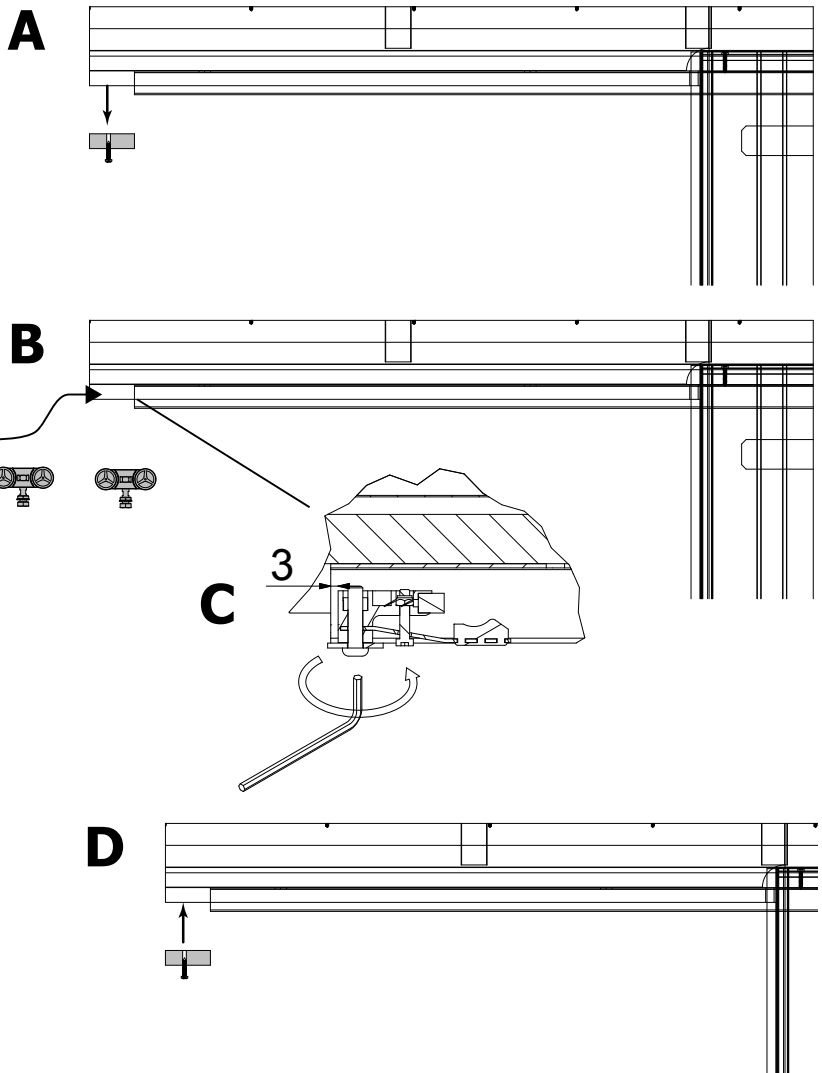

8.

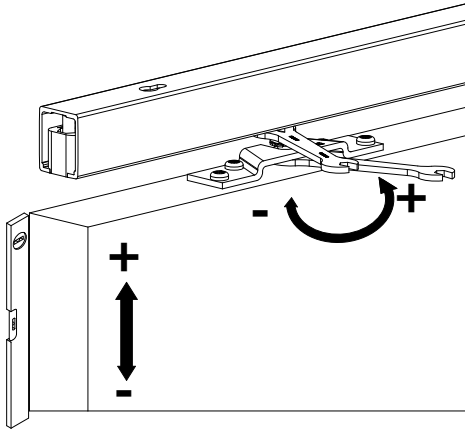
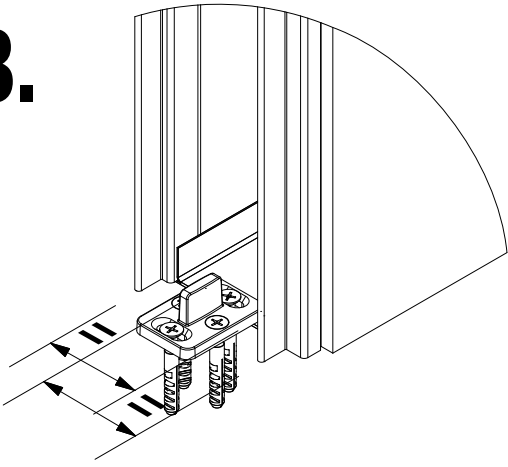

9.

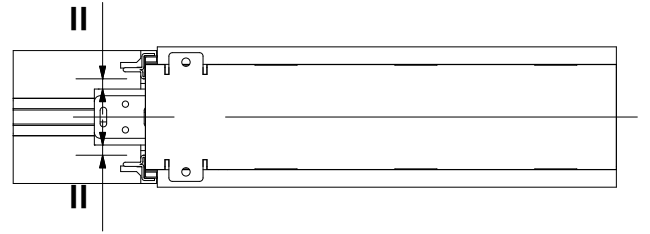
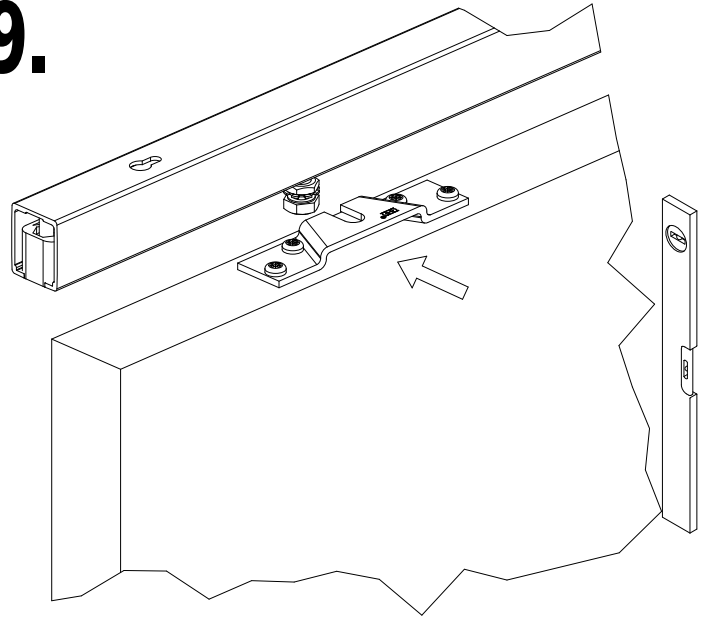

10.

