

**PROMAC**<sup>®</sup>

**JD-3285-M**  
**JD-3285-T**

**Drilling machine**

**JD-3285-M ...~230V, 50Hz**

**JD-3285-T ...~3L/N/PE, 400V, 50Hz**

**PARTS LIST**  
**ERSATZTEILLISTE**  
**LISTE DE PIÉCES**

**TOOL France SARL**  
9 rue des Pyrénées  
F-91090 LISSES  
France

[www.promac.fr](http://www.promac.fr)



2020-12

## Table of Contents

|                         |     |
|-------------------------|-----|
| Table of Contents ..... | 1   |
| Part Breakdown.....     | 2   |
| Part List .....         | 3-5 |
| Wiring Diagram.....     | 6   |



## Parts List for JD-3285-M/T Drilling machine

| Index No. | Part No.   | Description                     | Size       | Qty. |
|-----------|------------|---------------------------------|------------|------|
| 1         | JD3285-001 | Base                            |            | 1    |
| 2         | JD3285-002 | Column base                     |            | 1    |
| 3         | JD3285-003 | Hexagon bolt                    | M10×40     | 4    |
| 4         | JD3285-004 | Crank arm handle assembly       |            | 1    |
| 5         | JD3285-005 | Worm                            |            | 1    |
| 6         | JD3285-006 | pin                             |            | 1    |
| 7         | JD3285-007 | Helical gear                    |            | 1    |
| 8         | JD3285-008 | Holder                          |            | 1    |
| 9         | JD3285-009 | Corbel                          |            | 1    |
| 10        | JD3285-010 | Table lock handle set           |            | 1    |
| 11        | JD3285-011 | Hex bolt                        | M16×35     | 1    |
| 12        | JD3285-012 | Table                           |            | 1    |
| 13        | JD3285-013 | Bracket locking handle set      |            | 1    |
| 14        | JD3285-014 | Rack                            |            | 1    |
| 15        | JD3285-015 | Column                          |            | 1    |
| 16        | JD3285-016 | Hexagon socket socket set screw | M6×10      | 1    |
| 17        | JD3285-017 | Rack band                       |            | 1    |
| 18        | JD3285-018 | Keyless chuck                   | B16 1-16mm | 1    |
| 19        | JD3285-019 | Arbor                           | MT-3/B16   | 1    |
| 20        | JD3285-020 | Bearing                         | 6205       | 3    |
| 21        | JD3285-021 | Spindle                         |            | 1    |
| 22        | JD3285-022 | Washer                          |            | 1    |
| 23        | JD3285-023 | Quill                           |            | 1    |
| 24        | JD3285-024 | Bearing                         | 6204       | 1    |
| 25        | JD3285-025 | flat washer                     | 12         | 1    |
| 26        | JD3285-026 | Washer                          |            | 1    |
| 27        | JD3285-027 | Locknut                         |            | 1    |
| 28        | JD3285-028 | Pointer                         |            | 1    |
| 29        | JD3285-029 | Cross pan head screw            | M4×8       | 1    |
| 30        | JD3285-030 | Positioning screw               | M8×16      | 1    |
| 31        | JD3285-031 | Nut                             | M8         | 1    |
| 32        | JD3285-032 | Locking button                  |            | 1    |
| 33        | JD3285-033 | Dial                            |            | 1    |
| 34        | JD3285-034 | Lock Block                      |            | 1    |
| 35        | JD3285-035 | Gear shaft                      |            | 1    |
| 36        | JD3285-036 | Pin                             | 8×25       | 1    |
| 37        | JD3285-037 | Handle base                     |            | 1    |
| 38        | JD3285-038 | Handle lever                    |            | 3    |
| 39        | JD3285-039 | Ball                            |            | 3    |

## Parts List for JD-3285-M/T Drilling machine

| Index No. | Part No.    | Description            | Size        | Qty. |
|-----------|-------------|------------------------|-------------|------|
| 40        | JD3285-040  | Emergency stop switch  |             | 1    |
| 41        | JD3285-041  | Cross pan head screw   |             | 2    |
| 42        | JD3285-042A | Electromagnetic switch | KJD11-400V  | 1    |
|           | JD3285-042B | Electromagnetic switch | KJD11-230V  | 1    |
| 43        | JD3285-043  | Cross pan head screw   | M5×16       | 4    |
| 44        | JD3285-044  | Switch box             |             | 1    |
| 45        | JD3285-045  | Coil spring            |             | 1    |
| 46        | JD3285-046  | Spring shield          |             | 1    |
| 47        | JD3285-047  | Nut                    | M12         | 2    |
| 48        | JD3285-048  | LED light set          |             | 1    |
| 49        | JD3285-049  | Transformer            | 230V/3V     | 1    |
| 50        | JD3285-050  | Retainer ring          |             | 2    |
| 51        | JD3285-051  | Spline housing         |             | 1    |
| 52        | JD3285-052  | Washer                 |             | 1    |
| 53        | JD3285-053  | Spindle box            |             | 1    |
| 54        | JD3285-054  | Locking button         |             | 2    |
| 55        | JD3285-055  | Block                  |             | 1    |
| 56        | JD3285-056  | Hex bolt               | M8×16       | 1    |
| 57        | JD3285-057  | Handle                 |             | 2    |
| 58        | JD3285-058  | Motor rod              |             | 1    |
| 59        | JD3285-059  | Hex bolt               | M8×25       | 4    |
| 60        | JD3285-060  | flat washer            | 8           | 8    |
| 61        | JD3285-061  | Motor base             |             | 1    |
| 62        | JD3285-062  | Washer                 | 12          | 2    |
| 63        | JD3285-063  | Nut                    | M12         | 2    |
| 64        | JD3285-064  | Nut                    | M8          | 4    |
| 65        | JD3285-065A | Motor                  | 0.75kW 400V | 1    |
|           | JD3285-065B | Motor                  | 0.75kW 230V | 1    |
| 66        | JD3285-066  | Screw                  | M5×13       | 2    |
| 67        | JD3285-067  | Micro switch cover     |             | 1    |
| 68        | JD3285-068  | Micro switch           |             | 1    |
| 69        | JD3285-069  | Micro switch cover     |             | 1    |
| 70        | JD3285-070  | Cover set              |             | 1    |
| 71        | JD3285-071  | Spindle pulley         |             | 1    |
| 72        | JD3285-072  | Nut                    |             | 1    |
| 73        | JD3285-073  | Bearing                | 6202        | 2    |
| 74        | JD3285-074  | V-Belt                 | A29         | 1    |
| 75        | JD3285-075  | V-Belt                 | A27         | 1    |

## Parts List for JD-3285-M/T Drilling machine

| Index No. | Part No.   | Description                   | Size      | Qty. |
|-----------|------------|-------------------------------|-----------|------|
| 76        | JD3285-076 | Central pulley                |           | 1    |
| 77        | JD3285-077 | Central axle                  |           | 1    |
| 78        | JD3285-078 | Motor pulley                  |           | 1    |
| 79        | JD3285-079 | Block                         |           | 1    |
| 80        | JD3285-080 | Hex socket cap screw          | M8×20     | 2    |
| 81        | JD3285-081 | Micro switch                  |           | 1    |
| 82        | JD3285-082 | Hex screw                     | M10×8     | 2    |
| 83        | JD3285-083 | Spring                        | 1×6×15.75 | 2    |
| 84        | JD3285-084 | Steel ball                    | 8         | 2    |
| 85        | JD3285-085 | Chuck guard micro assy        |           | 1    |
| 86        | JD3285-086 | Hex socket cap screw          | M6×35     | 4    |
| 87        | JD3285-087 | Hex socket cap screw          | M6×12     | 1    |
| 88        | JD3285-088 | Spacer                        | 6         | 1    |
| 89        | JD3285-089 | Pin                           | 3×10      | 1    |
| 90        | JD3285-090 | Positioning bushing           |           | 1    |
| 91        | JD3285-091 | Chuck guard rod               |           | 1    |
| 92        | JD3285-092 | Hex socket cap screw          | M6×12     | 1    |
| 93        | JD3285-093 | Locking button                |           | 2    |
| 94        | JD3285-094 | Chuck guard                   |           | 1    |
| 95        | JD3285-095 | Cross countersunk head screw  | M6×40     | 3    |
| 96        | JD3285-096 | Chuck guard                   |           | 1    |
| 97        | JD3285-097 | LED light base                |           | 1    |
| 98        | JD3285-098 | Switch                        |           | 2    |
| 99        | JD3285-099 | Laser light base              |           | 4    |
| 100       | JD3285-100 | Cross laser light             |           | 2    |
| 101       | JD3285-101 | Cross head self-tapping screw | M2×9      | 2    |
| 102       | JD3285-102 | Cross head self-tapping screw | M2×6      | 2    |
| 103       | JD3285-103 | Cross head screw              | M4×12     | 4    |
| 104       | JD3285-104 | Cross head self-tapping screw | M9×16     | 4    |

## Wiring Diagram JD-3285-M/T Drilling machine

**JD-3285-T**  
**3L/N/PE, 400V, 50Hz**

**JD-3285-M**  
**~230V, 50Hz**

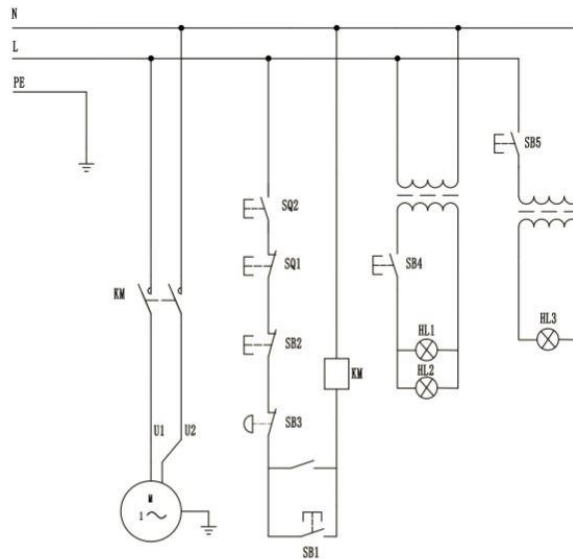
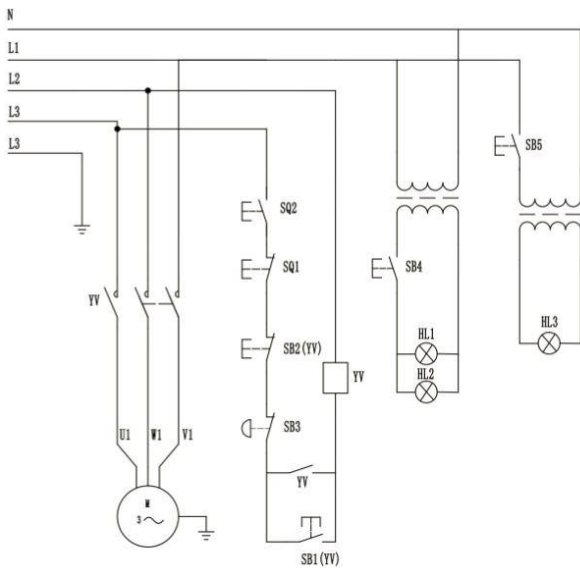

### Electrical Schematic Parts List

| ITEM | Part No.    | Description            | TYPE         | Qty. |
|------|-------------|------------------------|--------------|------|
| SB1  | JD3285-042A | Electromagnetic switch | KJD11-400V   | 1    |
|      | JD3285-042B | Electromagnetic switch | KJD11-230V   | 1    |
| SB2  | JD3285-042A | Electromagnetic switch | KJD11-400V   | 1    |
|      | JD3285-042B | Electromagnetic switch | KJD11-230V   | 1    |
| SB3  | JD3285-040  | Emergency stop switch  | LAY5         | 1    |
| SB4  | JD3285-098  | Switch                 | XCK-017      | 1    |
| SB5  | JD3285-098  | Switch                 | XCK-017      | 1    |
| SQ1  | JD3285-081  | Micro switch           | SV-165-1C25C | 1    |
| SQ2  | JD3285-068  | Micro switch           | KW7-03C      | 1    |
| HL1  | JD3285-100  | Cross laser light      | JGD-DC3V     | 1    |
| HL2  | JD3285-100  | Cross laser light      | JGD-DC3V     | 1    |
| HL3  | JD3285-048  | LED light set          | LD-TH918C-5S | 1    |
| M    | JD3285-065A | Motor                  | 0.75kW 400V  | 1    |
|      | JD3285-065B | Motor                  | 0.75kW 230V  | 1    |