

Gond à visser.
Poids du portail : 100Kg

Hinges screwing type.
Gate weight : 100 Kg

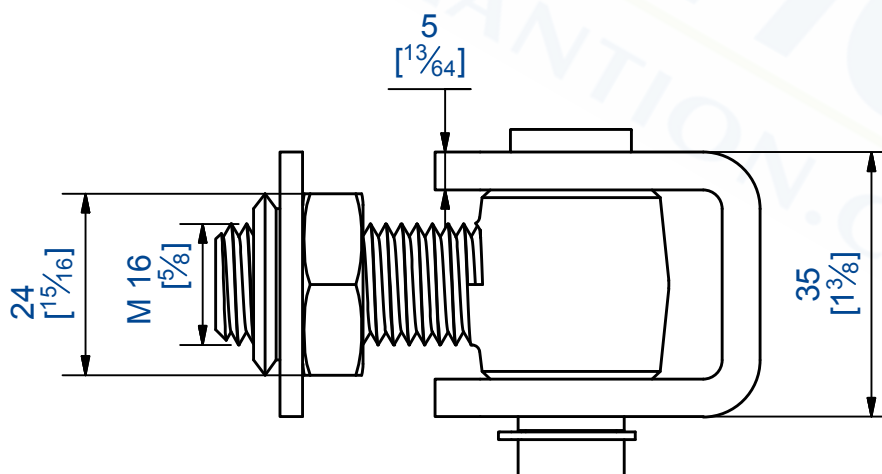
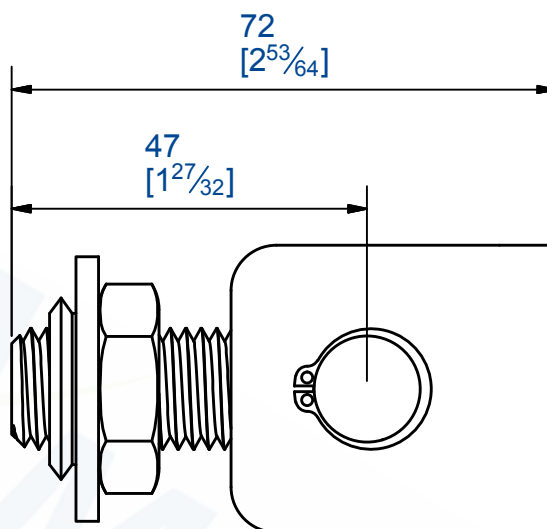

7,rue Gay Lussac
25000 BESANCON

Référence
Item Nr: **25163**

Rail associé
Combined track:

Gond à visser.
Poids du portail : 150Kg

Hinges screwing type.
Gate weight : 150 Kg

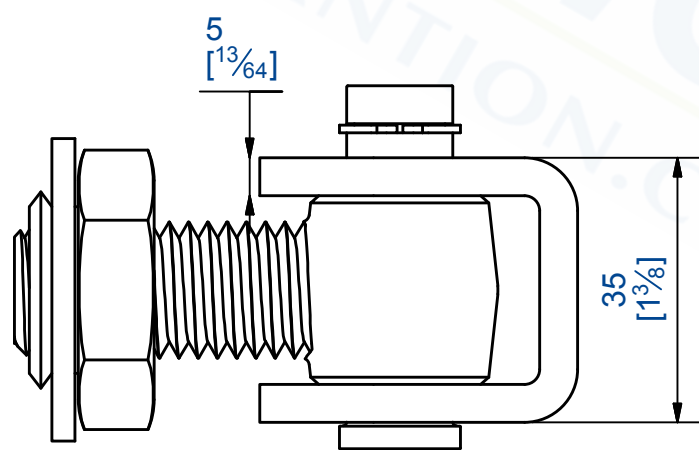
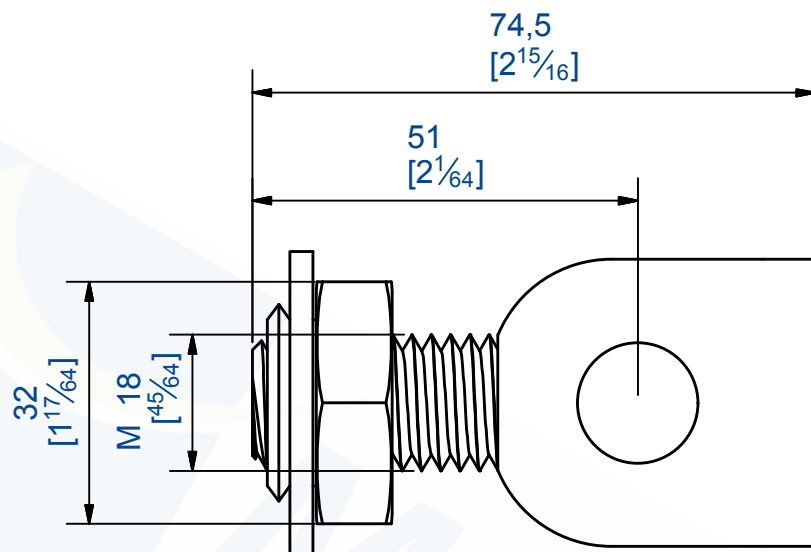

7,rue Gay Lussac
25000 BESANCON

Référence
Item Nr: **25183**

Rail associé
Combined track:

Gond à visser.
Poids du portail : 150Kg

Hinges screwing type.
Gate weight : 150 Kg

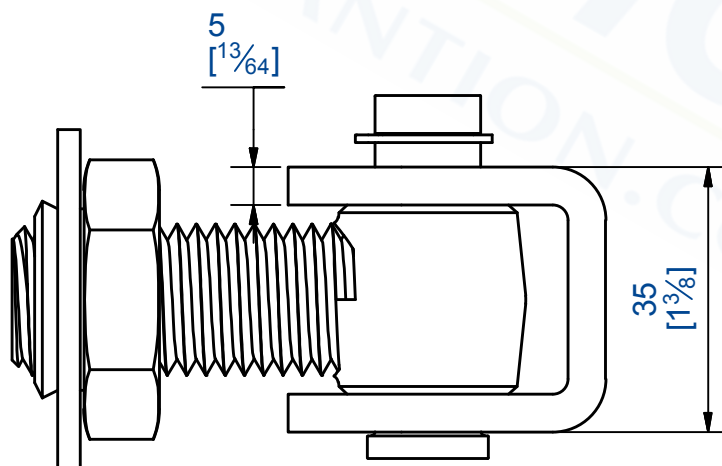
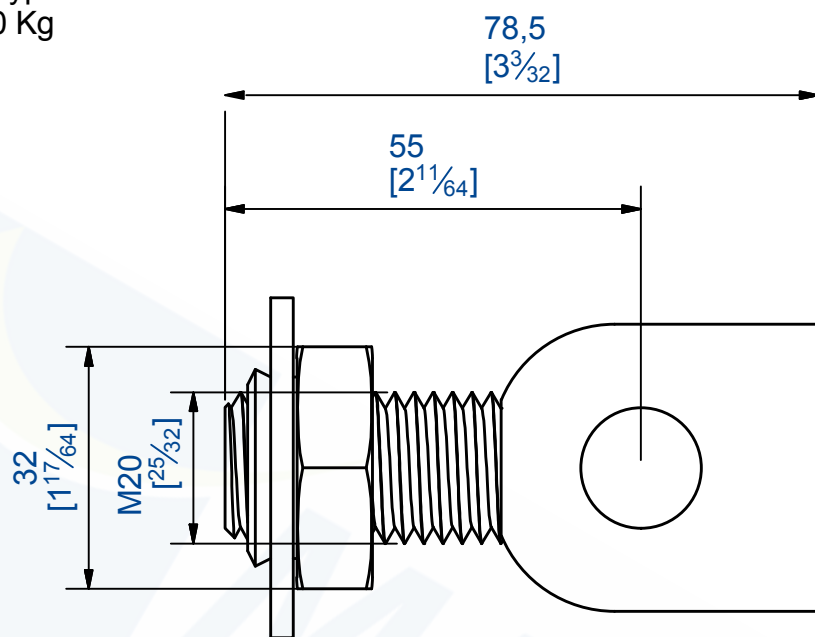

7,rue Gay Lussac
25000 BESANCON

Référence
Item Nr: **25203**

Rail associé
Combined track:

Gond à souder.
Poids du portail : 150Kg

Hinges welding type.
Gate weight : 150 Kg

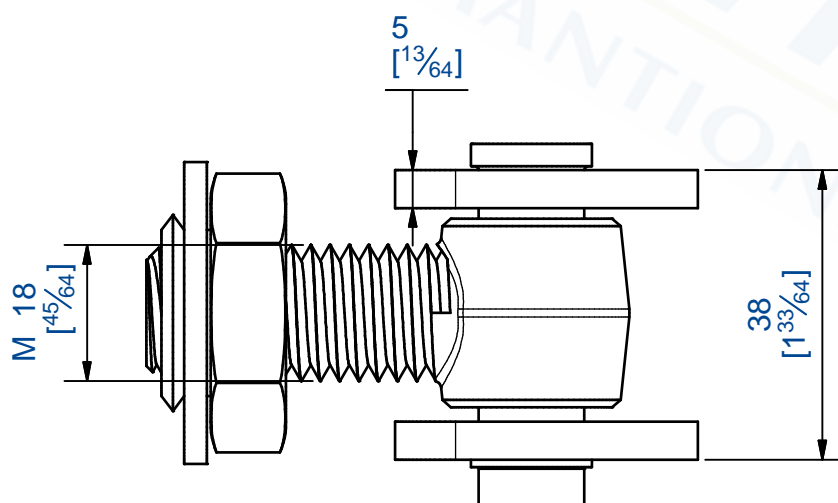
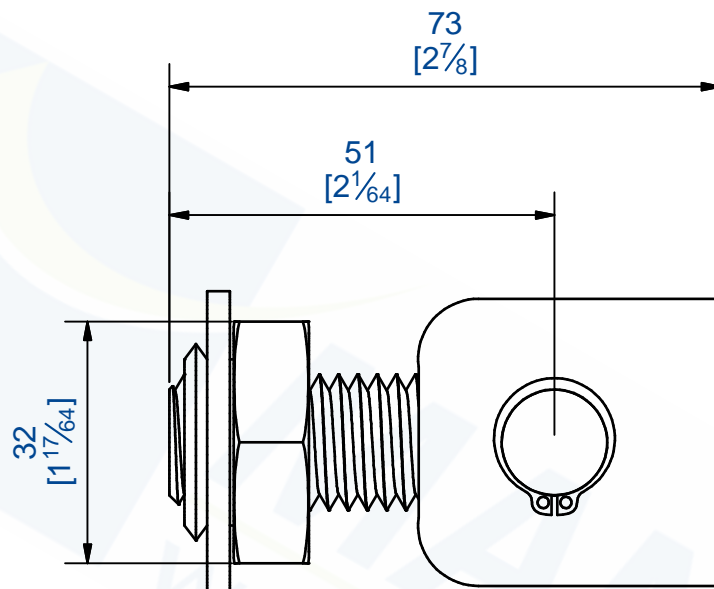

7,rue Gay Lussac
25000 BESANCON

Référence
Item Nr: **25183SO**

Rail associé
Combined track:

Gond à souder.
Poids du portail : 200Kg

Hinges welding type.
Gate weight : 200 Kg

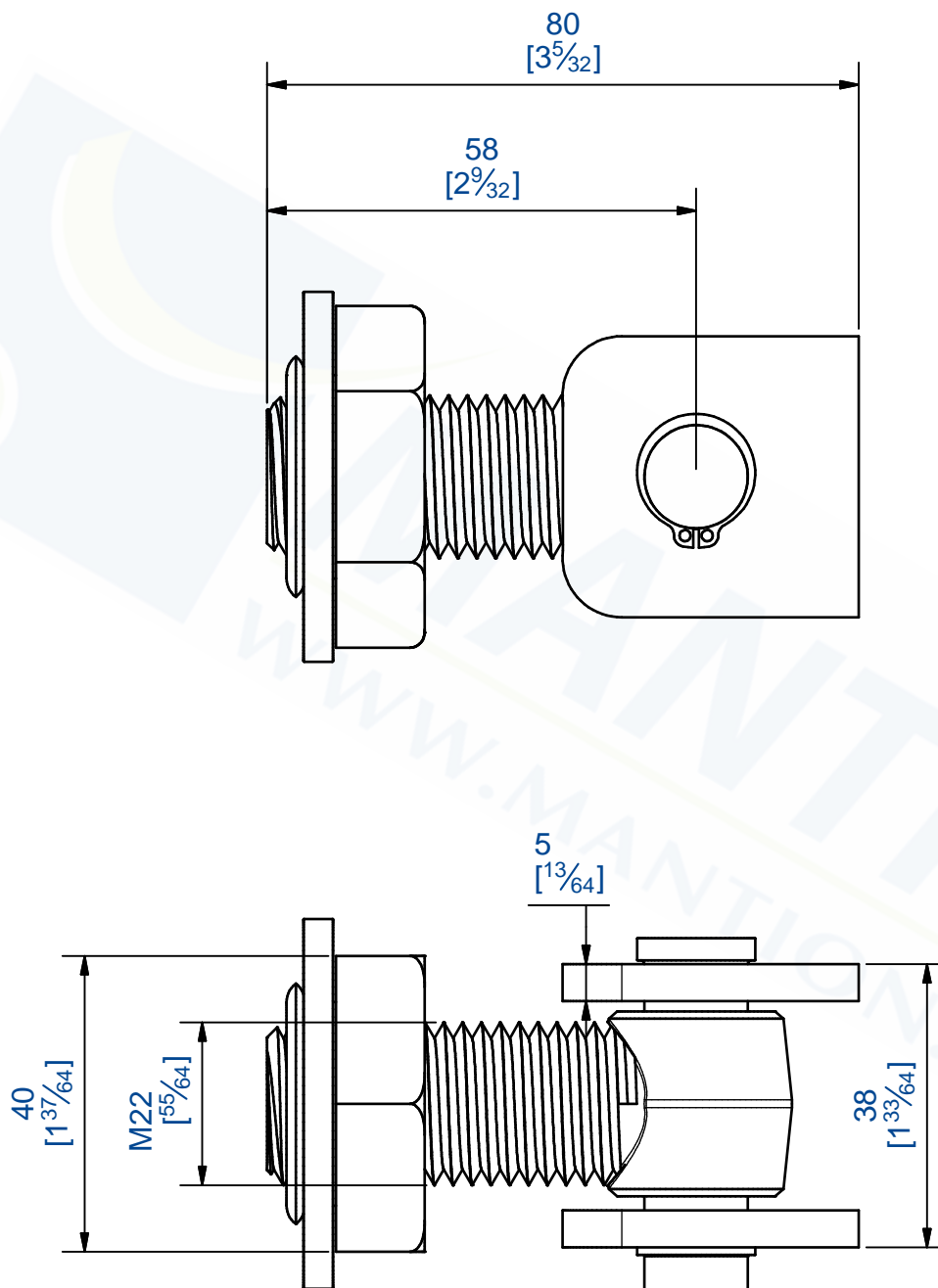

7,rue Gay Lussac
25000 BESANCON

Référence
Item Nr: **25223SO**

Rail associé
Combined track: