

8

7

6

5

4

3

2

1

ITEM	PART NUMBER	DESCRIPTION	REV	QTY	MANUFACTURER
1	TITAN-402-HF	STOCK 1.75" X 4" CUT TO 9.1	A	1	MOSSCNC
2	TITAN-402	STOCK 1.125" X 2.625" CUT TO 2.185"	A	2	MOSSCNC
3	MiteeBite-32075	FOR TITAN-402-HF	A	2	MITEEBITE
4	MiteeBite-26070	FOR TITAN-402-HF	A	2	MITEEBITE
5	MiteeBite-31200	FOR TITAN-402-HF	A	1	MITEEBITE

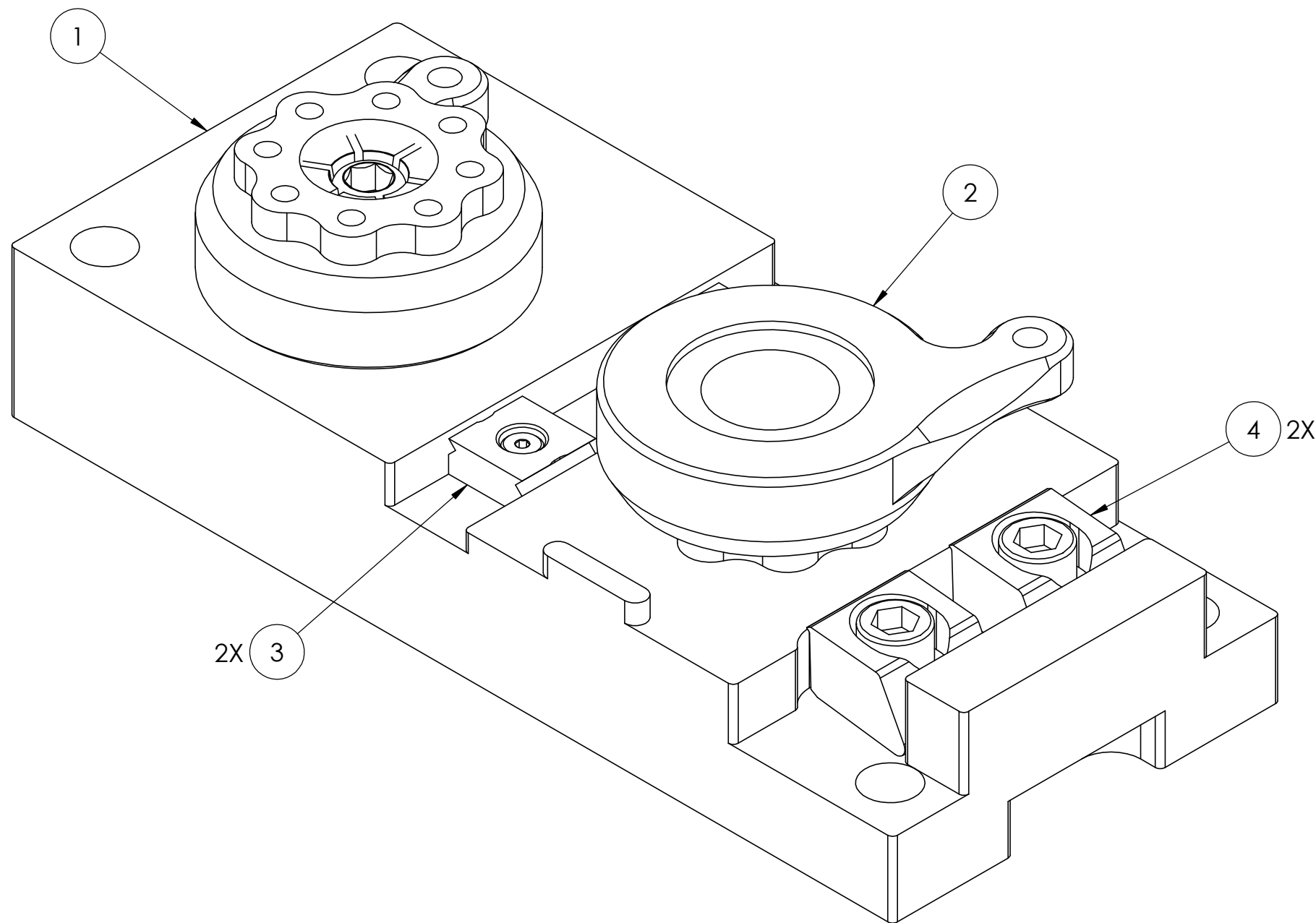

REV	DESCRIPTION	DATE	INITIALS
A	ORIGINAL DESIGN	11/5/22	NGM
B			
C			
D			
E			
F			
G			
H			

UNLESS OTHERWISE SPECIFIED
DIMENSIONS ARE IN INCHES.
ALL DIMENSIONS APPLY AFTER
ANY SURFACE TREATMENT
(i.e. ANODIZE, PLATING)

DECIMAL
X.X ±0.1
X.XX ±0.01
X.XXX ±0.005
X.XXXX ±0.0005

ANGULAR ±0.5°
SURFACE FINISH 64

CAD GENERATED DRAWING
DO NOT MANUALLY
UPDATE OR SCALE

SURFACE SHALL BE UNIFORM
AND FREE OF BURRS,
BLEMISHES, AND SCRATCHES.

MATERIAL:
SEE BOM

PART FINISH:
N/A

This document, including the information
contained herein, is the property of MOSSCNC,
and is considered confidential and proprietary
information. It is delivered on the express
condition that it not be used, disclosed, or
reproduced in whole or in part, for any reason
without prior written consent of MOSSCNC.

DESCRIPTION: TITAN-402-ASSY			
SCALE: 1:1	SHEET: 1 OF 1	DRAWING NUMBER: TITAN-402-ASSY	REV: A

MOSSCNC
NICHOLAS G. MOSS
RAVENA, NY 12143

DRAWN BY NICHOLAS G. MOSS