

AUTOMATIC
WEIGH-PRICE LABELLER

LS-4000



Image of
LS-4330/400



WEIGHING
DYNAMIC OR
STATIC



**LABEL
PRINTER**
PRINTHEAD / 3-4"



LABELLING
IN MULTIPLE
POSITIONS



8,000 PLUs
MEMORY



**TOUCH SCREEN
CONSOLE**
OPTIONAL

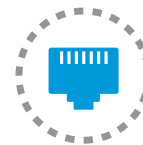

ETHERNET
TCP/IP



**METROLOGICAL
VERIFICATION**
OPTIONAL

DIMENSIONS

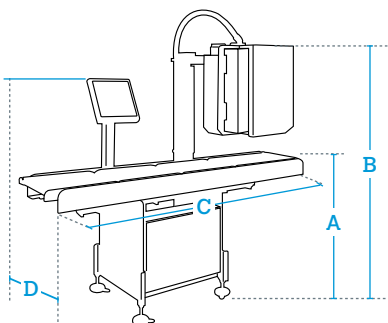

DATA IN mm

A	820 - 970 (adjustable legs)
B	1,485 - 1,895 (adjustable legs)
C	1,525 (with L400-L400-L600 conveyors)*
D	630 (for W280 conveyors)**

* These measurements correspond to the sum of the infeed, weighing and labelling conveyors. For other sizes, contacts us.

** For other sizes, contact us.

Specifications:

Outstanding functions

- Labelling of fix/variable weight/price.
- Discrimination by weight checking.
- Orders management.
- Labelling of totals.
- Generic traceability on label.
- Adapted to comply with EU Regulation 1169/2011 referring to food information.
- Barcodes:
 - EAN-8, EAN-13, EAN-128, CODE 128, ITF-14, GS1 Datamatrix and GS1 Databar (up to 4 codes per label).

Weighing

- **Weighing type:**
 - Dynamic or static.
- **Ranges depending on the dimensions of the weighing conveyor:**
 - 6 kg/2 g or 10 kg/5 g with conveyor of up to L400 x W400 mm.
 - 15 kg/5 g, 20 kg/10 g, 30 kg/10 g, 40 kg/20 g or 60 kg/20 g with conveyor of up to L600 x W500 mm.
 - 3 kg /1 g or other, contact us.

Labelling system

- **Printing type:**
 - Direct Thermal (DT) or Thermal Transfer (TT).
- **Printhead:**
 - Long-lasting 3" or 4".
- **Resolution:**
 - 8 dots/mm.

- **Label applicator type:**
 - Top labeller: "Air-jet®" (AA) or pneumatic piston.
 - Bottom labeller: by contact.
 - Side, front, rear or on corner (L) labeller: pneumatic piston.
- **Position of the label applicator:**
 - Top, bottom, side, front, rear or on corner (L) labelling.

Labels

- **Dimensions depending on the position of the label applicator and the inches of the printhead:**
 - Top, side, front, rear or on corner label: from W30 x L35 mm, up to W80 x L100 mm (3"). Up to W102 x L150 mm (4").
 - Bottom label: from W30 x L55 mm, up to W80 x L100 mm (3"). Up to W102 x L150 mm (4").

Construction

- **Structure:**
 - AISI 304 stainless steel and anodized aluminium.
- **Belts:**
 - Material and characteristics: Polyurethane, rigid or elastic depending on the equipment range. With FDA approval.
- **Console:**
 - Material: Stainless steel.
 - "Qwerty" keypad and backlit graphic LCD display.
 - 15" TFT touch screen, optional.
 - Height of top labeller regulated from console.

Communication to PC

- Ethernet TCP/IP.
- RS-232.

PC Software

- **RMS:** For equipment configuration, production data management and back up (LBS).
- **DLD:** For graphic design of labels.
- **Integration tools:** See section on software.

Power supply & compressed air

- **Electrical:** 230 V/50 Hz; 115 V/60 Hz.
- **Air:** max. 150 l/min (at 5-8 bar).

Possible integration with other equipment

- Dibal LP-3000 manual weigh-price labeller.
- Dibal GS-3000 batch collector (+ LP-3000).
- Aligner.
- Misaligner.
- 90° deflector.
- Dibal MD-5000 metal detector.
- X ray inspection systems.

MODELS:

LS-4330/350

- 1 infeed and 1 weighing L350 x W200 mm conveyor, and 1 labelling L600 x W200 mm conveyor.
- For products of up to L250 x W200 mm, and up to 3 kg (in dynamic weighing). Up to L300 x W200 mm in static weighing.
- 1 top labeller, direct thermal printing, 3" printhead and "Air-Jet®".
- Performance*: 100 labels/minute (with labels of W60 x L60 mm, and products of up to L150 mm and 1 kg). In MID conditions (M).

LS-4330/400

- 1 infeed and 1 weighing L400 x W280 mm conveyor, and 1 labelling L600 x W280 mm conveyor.
- For products of up to L300 x W280 mm, and up to 6 kg (in dynamic weighing). Up to L350 x W280 mm in static weighing.
- 1 top labeller, direct thermal printing, 3" printhead and "Air-Jet®".
- Performance*: 80 labels/minute (with labels of W60 x L60 mm, and products of up to L200 mm and 2 kg). In MID conditions (M).

LS-4330/600

- 1 infeed, 1 weighing and 1 labelling L600 x W400 mm conveyor.
- For products of up to L500 x W400 mm, and up to 15 kg (in dynamic weighing). Up to L550 x W400 mm in static weighing.
- 1 top labeller, direct thermal printing, 3" printhead and "Air-Jet®".
- Performance*: 70 labels/minute (with labels of W60 x L60 mm, and products of up to L350 mm and 2 kg). In MID conditions (M).

* Maximum performance will depend on the size, weight and morphology of the product, as well as on the regularity of the infeed of the products, dimensions and characteristics of the label, and MID conditions (M).

Options



> Touch screen console



> Second top labeller

Option	Characteristics	Ref.
Touch screen console	TFT 15".	Contact us
4" printhead	Labels up to W102 x L150 mm.	Contact us
12 dots/mm resolution		Contact us
Thermal transfer printing	For 3" or 4" printhead.	Contact us
1 pneumatic piston applicator (to replace the "Air-jet®")		Contact us
Extra piston kit (in addition to the chosen applicator)	For the application of labels of different sizes, an additional piston may be required. Interchangeable with the chosen applicator.	Contact us
Bottom labeller (to replace the top labeller)	Label application by contact, 3" printhead and direct thermal printing. Label dimensions: from W30 x L55 mm, up to W102 x L150 mm. Performance*: 40 labels/minute (with labels of W60 x L60 mm).	Contact us
Front or rear side labeller (to replace the top labeller)	Recommended for boxes.	Contact us
Side labeller (to replace the top labeller)	Recommended for boxes.	Contact us
Corner labeller (to replace the top labeller)	Recommended for boxes.	Contact us
Second top labeller (in addition to the top labeller)	For the application of two labels on the top of the product. 3" printhead, direct thermal printing and application of the label by "Air-Jet®". A second labeller means you can combine 3" and 4" printheads, direct thermal and thermal transfer printing, as well as "Air-Jet®" and piston applicators. Maximum performance is provided by the lowest speed applicator, reduced by 10% (approximated data to be confirmed in each case).	Contact us
Second bottom labeller (in addition to the top labeller)	Label application by contact, 3" printhead and direct thermal printing. Maximum performance is provided by the lowest speed applicator, reduced by 10% (approximated data to be confirmed in each case).	Contact us
L350 x W200 mm separation conveyor	For model LS-4330/350.	Contact us
L400 x W280 mm separation conveyor	For model LS-4330/400.	Contact us
L600 x W280 mm conveyor (to replace L400 x W280 mm conveyor)	For model LS-4330/400.	Contact us



> Second bottom labeller

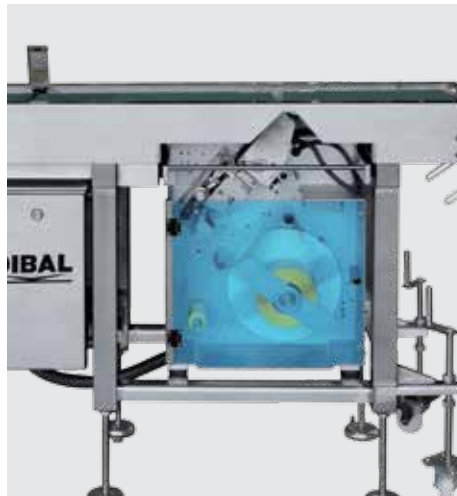

> Bottom labeller



> Side labeller

L800 x W280 mm conveyor (to replace L400 x W280 mm conveyor)	For model LS-4330/400.	Contact us
L800 x W280 mm weighing conveyor 4 load cells, not MID (to replace L400 x W280 mm conveyor)	For model LS-4330/400.	Contact us
L800 x W280 mm labelling conveyor (to replace L600 x W280 mm conveyor)	For model LS-4330/400.	Contact us
L600 x W400 mm separation conveyor	For model LS-4330/600.	Contact us
L400 x W400 mm conveyor (to replace L600 x W400 mm conveyor)	For model LS-4330/600.	Contact us
L800 x W400 mm conveyor (to replace L600 x W400 mm conveyor)	For model LS-4330/600.	Contact us
L800 x W400 mm weighing conveyor 4 load cells, not MID (to replace L600 x W400 mm conveyor)	For model LS-4330/600.	Contact us
Split belt	For transparent packs or irregular shape/ cylindrical products.	Contact us
Vertical detector on arch	For transparent packs or irregular shape products. Infeed conveyor with split belt necessary.	Contact us
Right to left operation	Standard operation: left to right.	Contact us
IP65 protection kit	Protected engines, bearings with lock, packaging gland, special load cell and heated detector.	Contact us
RMS Software	Equipment configuration, production data management and back up (LBS). (See section on software)	7340R1U3 7340RNU3
DLD Software	Graphic design of labels. (See section on software)	7340L1U3 7340LNU3
Wi-Fi	Wireless communications.	Contact us
Packed in phytosanitary wood case	Necessary depending on the destination.	PEEC080F
Metrological verification (M)	According to EU weighing directives (MID).	Contact us

* Maximum performance will depend on the size, weight and morphology of the product, as well as on the regularity of the infeed of the products, dimensions and characteristics of the label, and MID conditions (M).

Accessories



Ref: Contact us

Motorised conveyor

Infeed/output conveyor L1,000 x W280 mm, with smooth belt.



Ref: Contact us

Dibal Vision artificial vision camera

Contact us about applications.



Ref: Contact us

Barcode readers

Contact us about applications.



Ref: Contact us

Rollers conveyor

Rollers conveyor for transporting or accumulating products.



Ref: Contact us

Rotating table

To collect wrapped and/or labelled products.



Ref: Contact us

Rejectors

Rejection system.

Options: pneumatic piston, "Air-Jet®", rotating blade or folding conveyor.



Ref: Contact us

Product guiding system in infeed conveyor (standard)

For special guides, contact us.



Ref: Contact us

W200 mm exit ramp

Non-motorised PVC rollers for W200 mm conveyor.

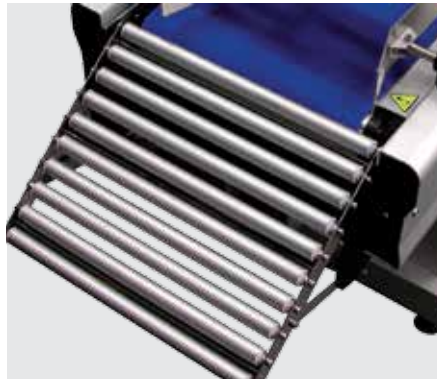

Ref: Contact us

W280 mm exit ramp

Non-motorised PVC rollers for W280 mm conveyor.



Ref: Contact us

W400 mm exit ramp

Non-motorised PVC rollers for W400 mm conveyor.



Ref: Contact us

Product turning device

To change the position or orientation of the products.

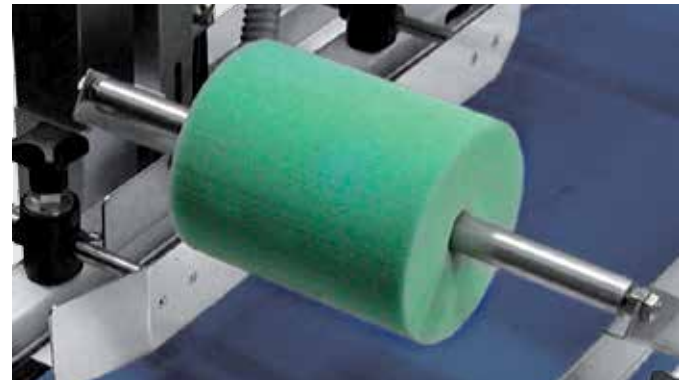

Ref: Contact us

Label fixers

For a better application of labels on products with irregularities on the application surface.

Options: brush roll, foam roll, foam piston, etc.



Ref: Contact us

Polycarbonate protector for weighing conveyor

To avoid external disturbances during the weighing process.



Ref: Contact us

4 wheels with brakes

Stud included.