

# C1050ES Tankless Water Heater

Engineering  
Submittal  
Sheet



# BOSCH

## Overview and Certifications

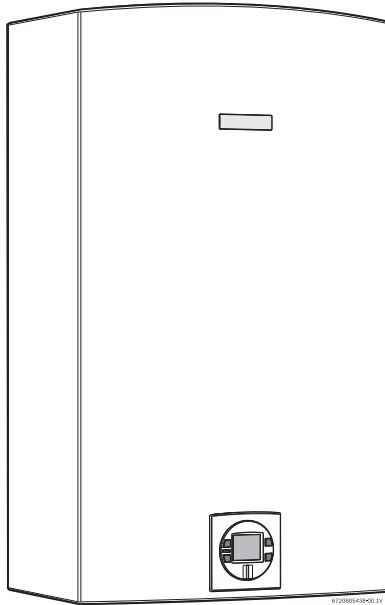

Massachusetts  
Plumbing Board  
Approved

## Engineering Specifications

The system shall consist of \_\_\_Model Greentherm C 1050 ES NG/LP tankless water heaters as manufactured by Bosch Thermotechnology. Water Heater shall be CSA/ANSI Z21.10.3 listed. Water Heater shall have an input of 199,000 BTU/Hr with a gross output of 184,500 BTU/Hr when fired with natural gas. Water Heater shall operate with a 96% ANSI Z21.10.3 efficiency. Water Heater shall have a recovery of 285 gallons per hour at a 77°F temperature rise. Water Heater shall have Low NOx emissions and is 2012 SCAQMD NOx certified to rule 1146.2.

### CONSTRUCTION

Water Heater shall be gas fired, condensing tankless design with a modulating power burner and negative pressure gas valve. Burner shall be capable of 10:1 turndown of firing, without loss of combustion efficiency. Primary heat exchanger/ combustion chamber shall incorporate a multi pass copper tube and fin design with internal turbulators. Secondary condensing heat exchanger shall incorporate a multi-pass aluminum heat exchanger of fin tube design with copper water path to prevent

galvanic corrosion. Heat exchangers shall be rated for maximum working pressure not less than 150 psig.

The Water Heater shall be equipped with a computer controlled active bypass valve that significantly improves water temperature stability. On the cold water inlet connection the Water Heater shall be equipped with an externally accessible in-line water filter.

The Water Heater control panel shall be a single printed circuit board in water-resistant plastic enclosure. The entire Water Heater control panel shall be Underwriters Laboratories approved.

The control panel shall contain: embedded control board incorporating LCD display to read temperature, and tactile buttons for output power, temperature, and programming control; CPU board houses all control functions; power transformer; ignition spark module; and unique connections

Bosch Thermotechnology Corp.  
Londonderry, NH • Ft. Lauderdale, FL

# C1050ES

## Tankless Water Heater



### Engineering Specifications

transformer; ignition spark module; and unique connections for each sensor or component. The control board shall be field replaceable. The combustion safeguard/flame monitoring system shall utilize spark ignition and a rectification type flame sensor. The control panel hardware shall support wireless remote communications if the wireless module is installed. The controls shall include extensive self-diagnostic capabilities that incorporate a minimum of 20 separate fault codes and 8 programmable system categories.

The Water Heater shall come equipped with power cord and shall operate on 120V/1/60Hz electrical service.

#### INSTALLATION

All aspects of installation of Water Heater system shall be in strict accordance with manufacturer's instructions. Materials shall conform to all manufacturer's recommendations including a manufacturer listed vent system.

Venting options shall include PP twin pipe venting, schedule 40 PVC and CPVC, a PP concentric up and out vent system, and a PP common venting system for up to 4 Water Heaters in either side by side or back to back arrangement.

Water Heater system piping shall be field constructed of materials as specified. Water Heater shall be installed with individually isolating shutoff valves for service and maintenance, and a hot water hose connection for field testing. Water Heater shall have an ASME approved temperature/pressure relief valve with a setting of 150 psig. Water Heater shall require a minimum gas pressure of 3.5" W.C. (Natural Gas) at 1,000 scfh (full load rated capacity).

#### MODE OF OPERATION

Water Heater shall include integral factory wired operating controls to control all operation and energy input. Control of discharge water temperature shall be set through an internal setpoint with a field adjustment of 100°F to 140°F. A high temperature accessory shall be available that when installed allows the Water Heater to produce up to 184°F. Water Heater shall be capable of maintaining the outlet temperature within an accuracy of  $\pm 2^\circ\text{F}^*$ . This shall be accomplished by modulation of firing rate from 100% to 10% of rated input. Water Heater shall operate with an Inverse Efficiency Curve, with maximum efficiency achieved at minimum firing input.

\* based on static stability test

#### MULTI UNIT CASCADES

Up to 24 Water Heaters plumbed in parallel shall operate in a cascade configuration using the Cascading Kit. This accessory shall stage Water Heaters based on demand activating or deactivating other Water Heaters as needed.

#### WARRANTY

The heat exchangers shall carry a 15-year limited warranty against leakage due to defects in materials or workmanship or corrosion in a residential, non-direct recirculation system, subject to the manufacturer's warranty terms and conditions and water quality requirements. All other parts and components provided by Bosch shall carry a 5 year limited warranty against defects in materials or workmanship subject to the terms and conditions of the manufacturer's warranty.

OR

The heat exchangers shall carry a 5-year limited warranty against leakage due to defects in materials or workmanship or corrosion in a commercial installation, subject to the manufacturer's warranty terms and conditions and water quality requirements. All other parts and components provided by Bosch shall carry a 5 year limited warranty against defects in materials or workmanship subject to the terms and conditions of the manufacturer's warranty.

# C1050ES Tankless Water Heater



## Dimensions and Connections

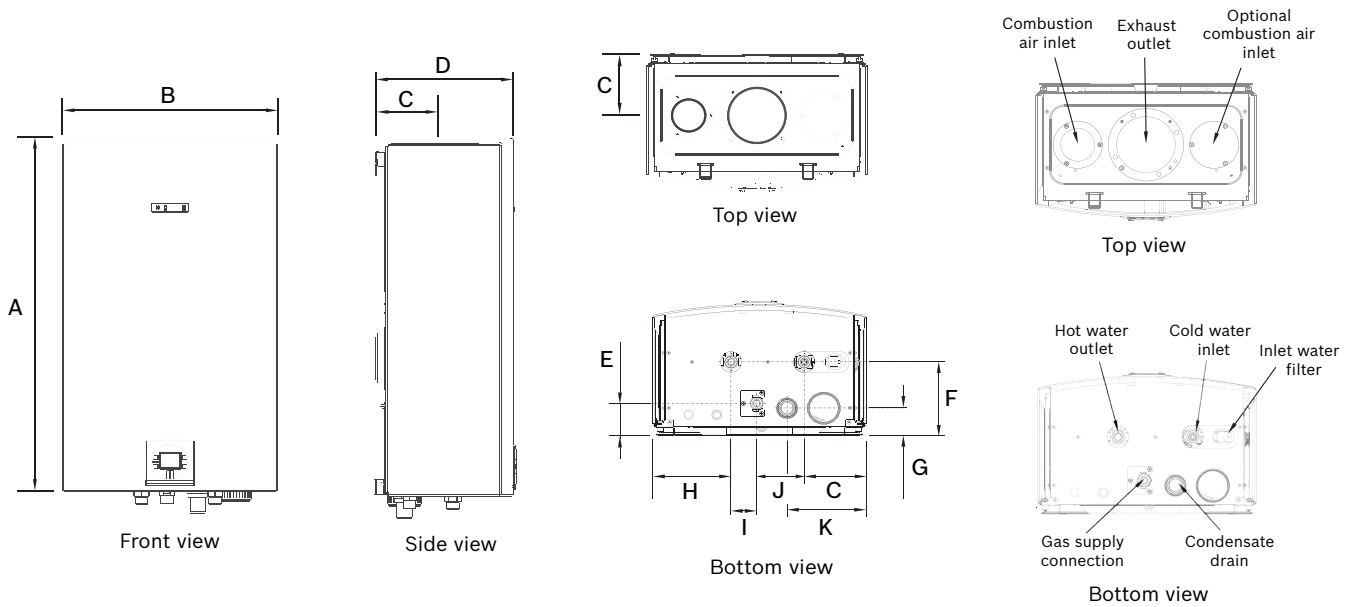

## Dimensions

	Unit	A	B	C	D	E	F	G	H	I	J	K
<b>Value</b>	Inches	30½	17⅞	5¼	11¼	2¾	6⅝ <sub>16</sub>	2⅝ <sub>16</sub>	6½	2⅝ <sub>16</sub>	4⅝ <sub>16</sub>	6 <sup>10</sup> / <sub>16</sub>

## Performance Data

	Unit	Value
Maximum gas input	BTU	199,000
Minimum input	BTU	19,900
Maximum output	BTU	184,500
Minimum output	BTU	18,300
Thermal efficiency	%	96
Energy factor	—	0.95

# C1050ES Tankless Water Heater



# BOSCH

Operational Data		
	Unit	Value
C 1050 ES NG / Natural Gas - part number	-	7736501515
C 1050 ES LP / Liquid Propane - part number	-	7736501517
Weight	lbs	74
Electrical voltage mains	VAC / Hz	120 / 60
Power consumption max load	A	≤ 2.5
Power consumption idle	mA	40
Min. Inlet gas pressure NG / LP	Inch W.C.	3.5 / 8
Max. Inlet gas pressure NG / LP	Inch W.C.	10.5 / 13
Maximum Output Temperature	°F	140
Max. Working pressure	psi	150
Min. Working pressure (single unit / cascade)	psi	30 / 50
Min. Activation rate	GPM	0.5
Relief valve pressure rating	psi	150
Venting category	-	IV
Approved vent or combustion air pipe material - United States	-	PP concentric up and out venting, PVC sched. 40, PVC-DWV, CPVC sched. 40, ABS-DWV sched. 40, PP common venting system for up to 4 units
Approved vent or combustion air pipe material - Canada	-	CSA or ULC certified only (ULCS636)

### Clearances

Top View

Front View

Description	Unit	Recommended Minimum clearance
Side clearance W1	Inch	1
Front clearance W2*	Inch	1
Top clearance W3	Inch	12
Floor clearance W4	Inch	12
Rear clearance W5	Inch	0

\* 24 inches recommended for servicing.

**Required direct vent terminal clearances (twin pipe / concentric penetration)**

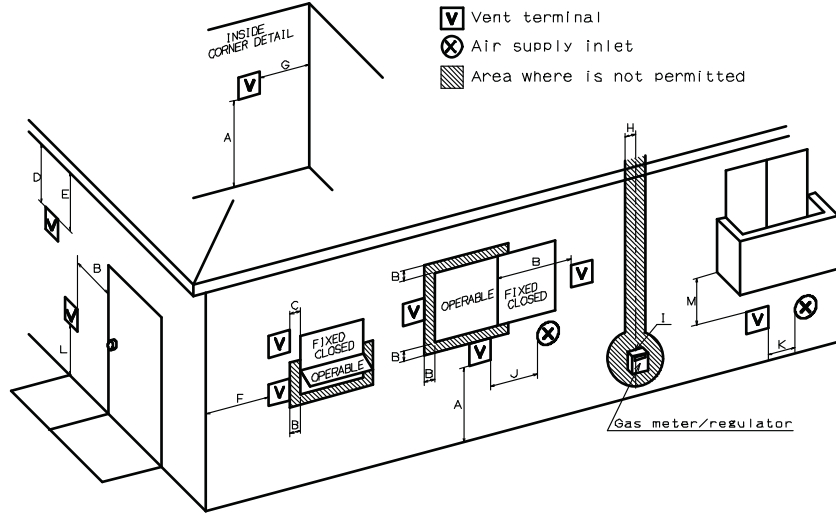

**Clearance Data**

Item	Description	Value	Canadian installations <sup>1)</sup>	U.S. installations <sup>2)</sup>
A	Clearance above grade, veranda, porch, deck or balcony	Inch	12	12
B	Clearance to window or door that may be opened	Inch	36	12
C	Clearance to permanently closed window	Inch	*	*
D	Vertical clearance to ventilated soffit located above the vent terminator within a horizontal distance of 2 feet (61cm) from the center line of the terminator	Inch	*	*
E	Clearance to unventilated soffit	Inch	*	*
F	Clearance to outside corner	Inch	*	*
G	Clearance to inside corner	Inch	*	*
H	Clearance to each side of center line extended above meter/regulator assembly	-	36 in. within a height 15 feet above meter/ regulator assembly	*
I	Clearance to service regulator vent outlet	Inch	36	*
J	Clearance to non-mechanical air supply inlet to building or the combustion air inlet to any other application	Inch	36	*
K	Clearance to mechanical air supply inlet	Inch	72	36 in. above if within 10 feet horizontally
L	Clearance above paved sidewalk or paved driveway located on public property	Inch	84 <sup>3)</sup>	*
M	Clearance under veranda, porch deck or balcony	Inch	12 <sup>4)</sup>	*

1) In accordance with the current CSA B149.1 Natural Gas and Propane Installation Code

2) In accordance with the current ANSI Z223.1 / NFPA 54 National Fuel Gas Code

3) A vent shall not terminate directly above a sidewalk or paved driveway that is located between two single family dwellings and serves both dwellings.

4) Permitted only if veranda, porch, deck or balcony is fully open on a minimum of two sides beneath the floor.

\* For clearances not specified in ANSI Z223.1 / NFPA 54 or CSA-B149.1, one of the following shall be indicated:

a) A minimum clearance value determined by testing in accordance with section 2.20, or;

b) A reference to the following footnote:

"Clearance in accordance with local installation codes and the requirements of the gas supplier."

**Required other than direct vent terminal clearances (single pipe penetration)**

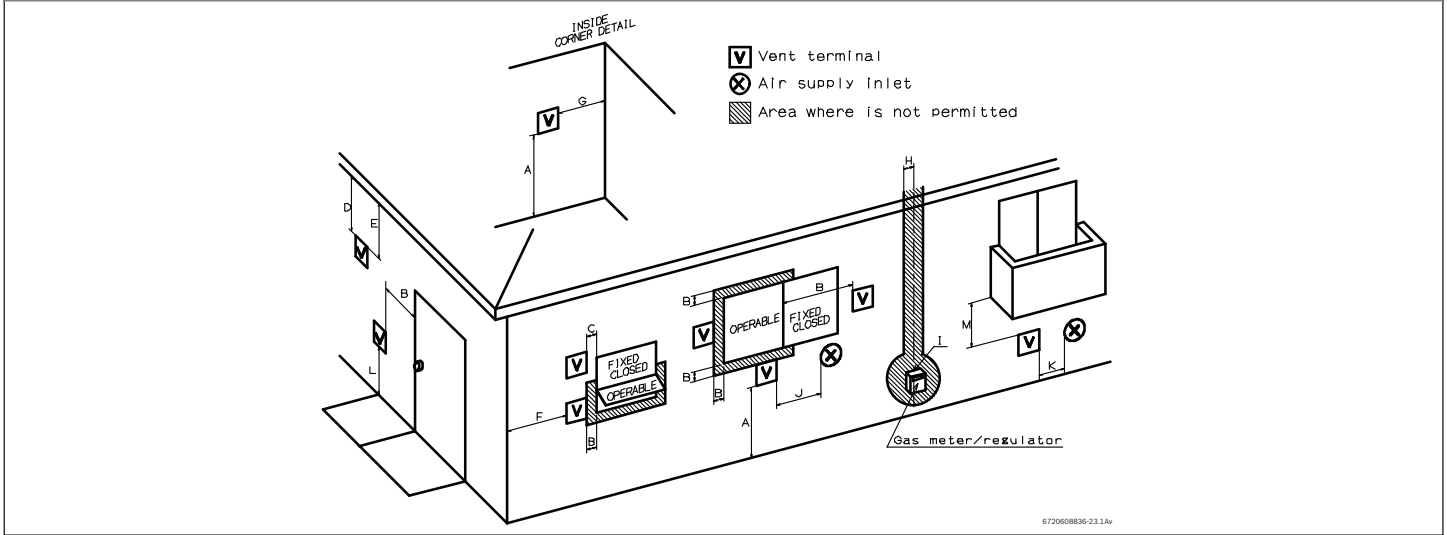

672068836-23.1Av

**Clearance Data**

Item	Description	Value	Canadian installations <sup>1)</sup>	U.S. installations <sup>2)</sup>
A	Clearance above grade, veranda, porch, deck or balcony	Inch	12	12
B	Clearance to window or door that may be opened	Inch	36	4 feet below or to side of opening; 1 foot above opening
C	Clearance to permanently closed window	Inch	*	*
D	Vertical clearance to ventilated soffit located above the vent terminator within a horizontal distance of 2 feet (61cm) from the center line of the terminator	Inch	*	*
E	Clearance to unventilated soffit	Inch	*	*
F	Clearance to outside corner	Inch	*	*
G	Clearance to inside corner	Inch	*	*
H	Clearance to each side of center line extended above meter/regulator assembly	-	36 in. within a height 15 feet above meter/regulator assembly	*
I	Clearance to service regulator vent outlet	Inch	36	*
J	Clearance to non-mechanical air supply inlet to building or the combustion air inlet to any other application	Inch	36	4 feet below or to side of opening; 1 foot above opening
K	Clearance to mechanical air supply inlet	Inch	72	36 in. above if within 10 feet horizontally
L	Clearance above paved sidewalk or paved driveway located on public property	Inch	84 <sup>3)</sup>	84
M	Clearance under veranda, porch deck or balcony	Inch	12 <sup>4)</sup>	*

1) In accordance with the current CSA B149.1 Natural Gas and Propane Installation Code

2) In accordance with the current ANSI Z223.1 / NFPA 54 National Fuel Gas Code

3) A vent shall not terminate directly above a sidewalk or paved driveway that is located between two single family dwellings and serves both dwellings.

4) Permitted only if veranda, porch, deck or balcony is fully open on a minimum of two sides beneath the floor.

\* For clearances not specified in ANSI Z223.1 / NFPA 54 or CSA-B149.1, one of the following shall be indicated:

a) A minimum clearance value determined by testing in accordance with section 2.20, or;

b) A reference to the following footnote:

"Clearance in accordance with local installation codes and the requirements of the gas supplier."

Bosch Thermotechnology Corp.  
Londonderry, NH • Ft. Lauderdale, FL

**Water Heating Capacity Curve**

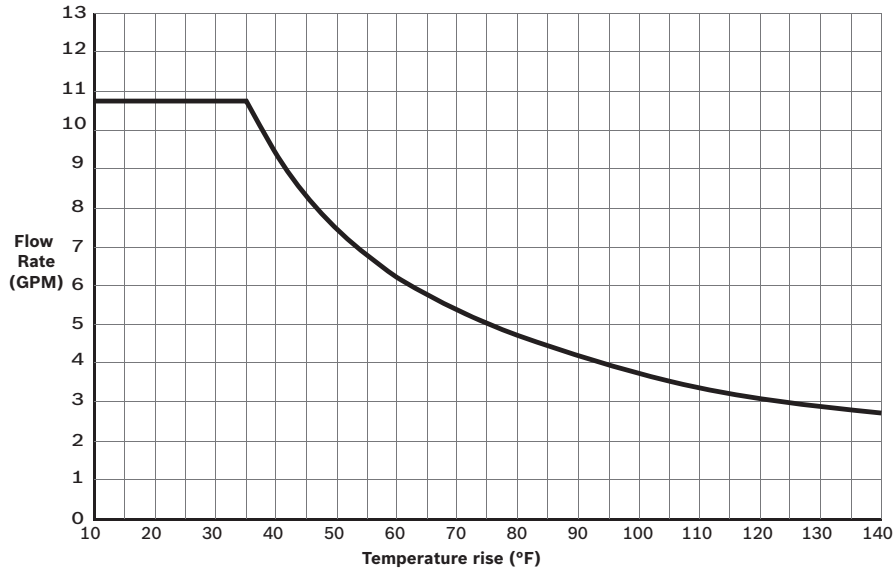

Water Heating Capacity Data	
Temperature Rise °F	Flow Rate GPM
35	10.7
45	8.3
55	6.8
65	5.8
75	5.0
90	4.2
100	3.7
120	3.1
140	2.7

\* 35°F capacity is based on installation with a mixing valve to overcome typical pressure loss through the water heater and system.

**Tankless Components**

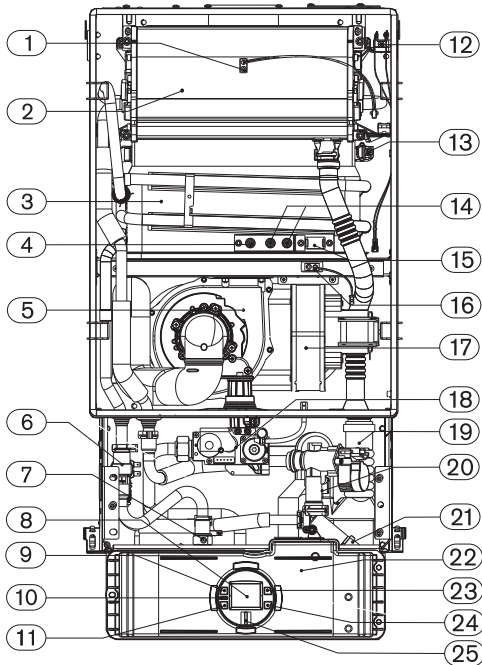

**Components Legend**

- 1 Exhaust temperature sensor
- 2 Condensing heat exchanger
- 3 Heat exchanger
- 4 Ionization sensor
- 5 Primary fan (Mixer)
- 6 Bypass valve
- 7 Hot water temperature sensor
- 8 LCD display
- 9 On/Off button
- 10 Reset button
- 11 Program button
- 12 Flue gas limiter
- 13 Heat exchanger overheat sensor (ECO)
- 14 Ignition electrodes
- 15 Observation window
- 16 Backflow temperature sensor
- 17 Secondary air fan
- 18 Gas valve
- 19 Condensate trap
- 20 Water valve with flow & cold water temperature sensors
- 21 Inlet water filter
- 22 Control unit
- 23 Up button
- 24 Down button
- 25 LED