



ISCA-121

Tag: _____

**Industry Standard
Single Vertical
Adjustable Closet Carrier**

SPECIFICATION: Watts Drainage Products ISCA-121 *Industry Standard* single vertical adjustable water closet carrier with epoxy coated cast iron fitting 4"(102) no hub waste and 2"(51) no hub vent connections, epoxy coated cast iron patent pending compression seal faceplate assembly, epoxy coated cast iron foot supports adjustable for standard and wheelchair height, adjustable ABS nipple with integral test cap and neoprene bowl gasket, plated hardware and chrome cap nuts. Carrier complies with requirements of ASME A112.6.1M up to a 500 lb. (227 kg.) static load.

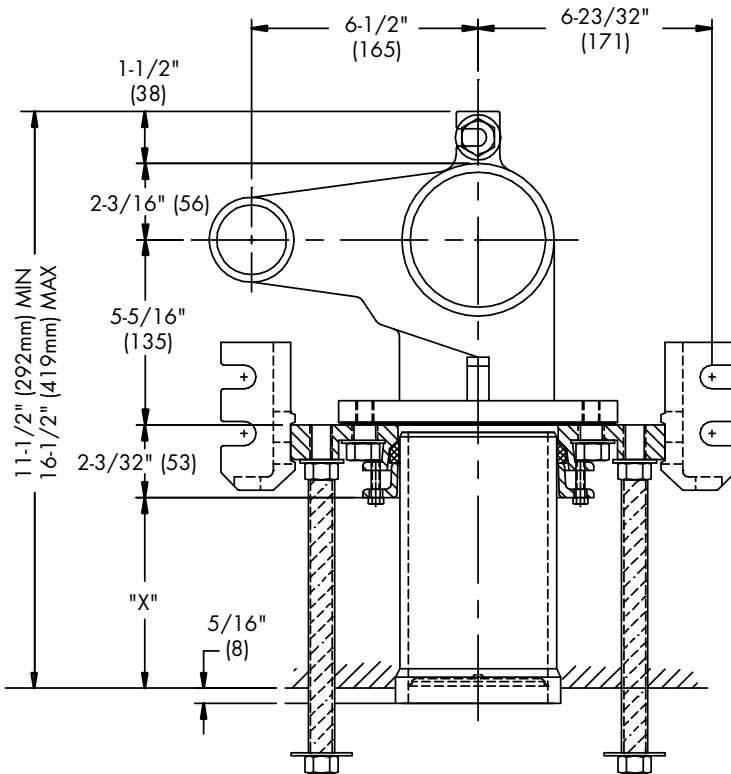

Suffix	Options (Select One or More) Description	
-BF	Assy. for 4" C/L Back Outlet Bowl	<input type="checkbox"/>
CA-100-EXT	Aux. Support System w/Extended Nipple	<input type="checkbox"/>
-CI	Cast Iron Nipple	<input type="checkbox"/>
-HS	Hub & Spigot Connections	<input type="checkbox"/>
-M1	ABS Extended Nipple (Up to 24")	<input type="checkbox"/>
-M11	Tiling Frame	<input type="checkbox"/>
-M20	Flush Valve Support	<input type="checkbox"/>
-US	Buy American Compliant	<input type="checkbox"/>

NOTICE

Siphon jet (4 bolt) arrangement shown. Invert faceplate assembly for blow-out (3 bolt) bowls.

Anchor legs to concrete floor with minimum 1/2" (13) anchor bolts (by others).

X = 5-3/4" (146) Maximum with Standard Nipple

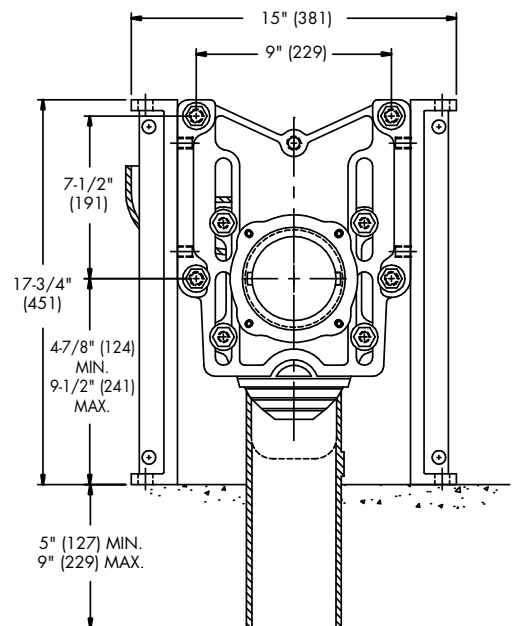

NOTICE

The information contained herein is not intended to replace the full product installation and safety information available or the experience of a trained product installer. You are required to thoroughly read all installation instructions and product safety information before beginning the installation of this product.

Job Name _____

Contractor _____

Job Location _____

Contractor's P.O. No. _____

Engineer _____

Representative _____

Watts product specifications in U.S. customary units and metric are approximate and are provided for reference only. For precise measurements, please contact Watts Technical Service. Watts reserves the right to change or modify product design, construction, specifications, or materials without prior notice and without incurring any obligation to make such changes and modifications on Watts products previously or subsequently sold.

USA: Tel: (800) 338-2581 • Fax: (828) 248-3929 • Watts.com

Canada: Tel: (905) 332-4090 • Fax: (905) 332-7068 • Watts.ca

Latin America: Tel: (52) 81-1001-8600 • Fax: (52) 81-8000-7091 • Watts.com

ES-WD-ISCA-121-USA 1621



A Watts Water Technologies Company