

J M Goldson

community preservation
+ planning

PROJECT TEAM: JM GOLDSON
RKG ASSOCIATES INC, TOOLE DESIGN
GROUP, BOB MITCHELL FAICP



Winchester Master Plan Update

COMMUNITY FORUM 2/26/19

PRESENTED BY: JENNIFER GOLDSON, AICP, AND ANNA CALLAHAN, JM GOLDSON LLC



What is a Master Plan? Why do one?

Past



•WINCHESTER•



Present



Future



How should town
policies shape the future
of the community?

How do town policies shape the future of the community?

How to use town funds,
property, and time?

Revoke, amend, or create
new local regulations?



Building siting, massing, and use are controlled by local zoning regulations.

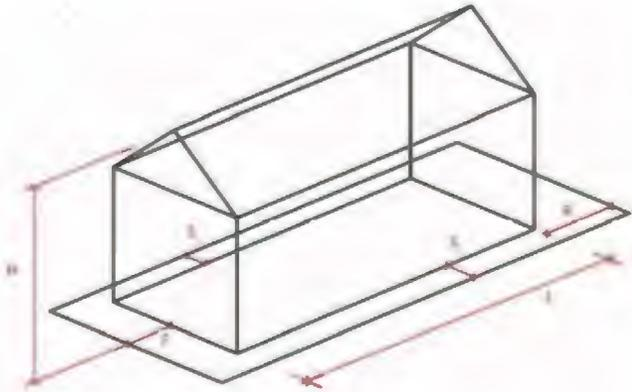

Land use directly influences the financial health of community.

New development contributes to local property tax revenues and service costs



A small town, like every human community, is characterized by tradition, continuity, and change.

You must chose the right balance.

This is the greatest challenge.

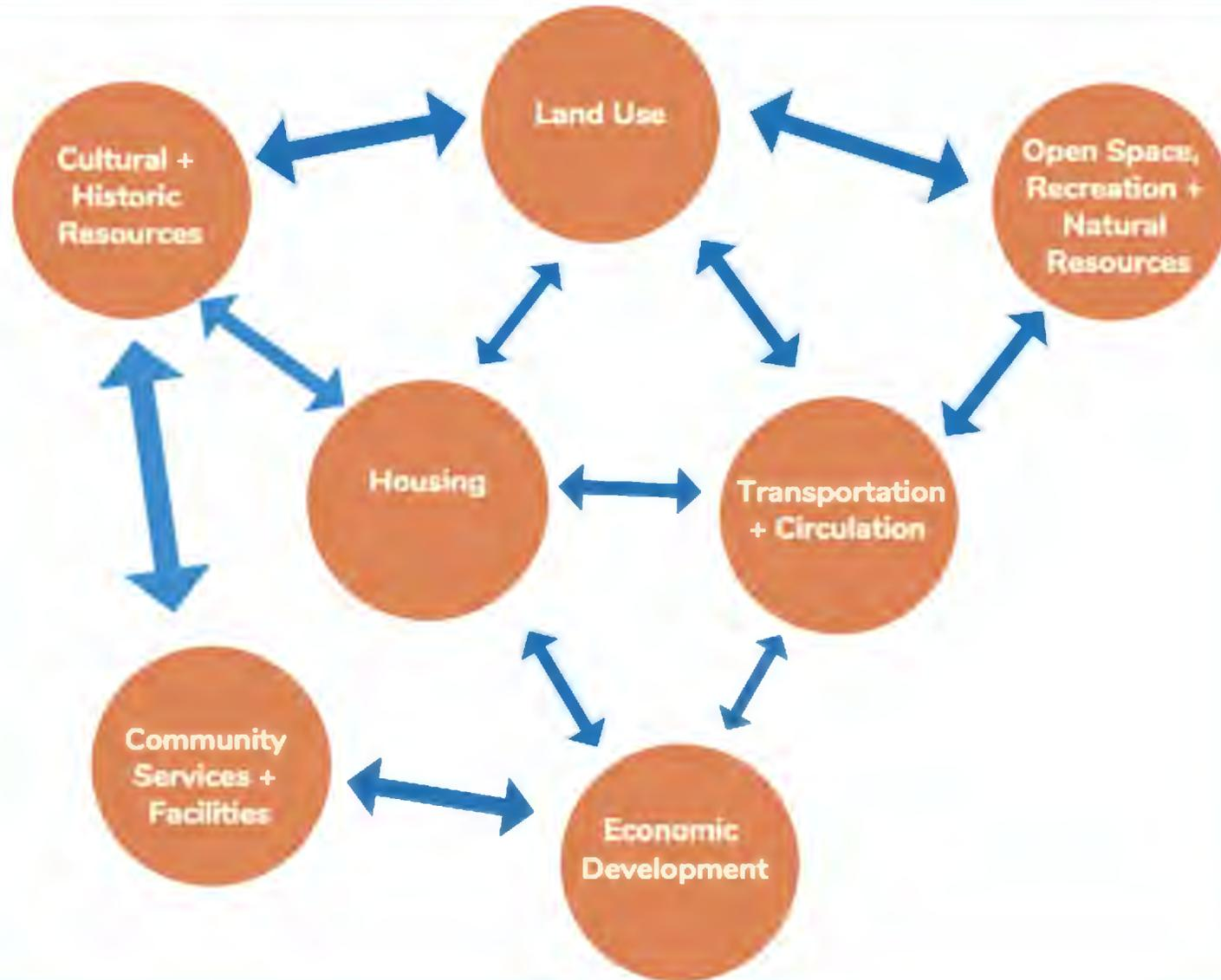

Making informed decisions about growth and development is not easy.

Decisions that affect one aspect of the system can ripple and influencing the whole system.

Setting Priorities



The major failure of many master plans has been trying to do too much at once.

Effective plans work to set clear, realistic priorities and create accountability.

- 1. Be facilitators**
- 2. Provide information**
- 3. Create a framework to consider choices**
- 4. Analyze choices**
- 5. Pull it all together**

But, ultimately, the decisions are not ours to make.

MPSC: Oversee the work of the consultant and provide regular guidance.

Planning Board: Sole authority to adopt the plan.

**You come here as residents, business owners, property owners,
and employees.**

But, most importantly, you are the town's **CUSTODIANS.**



People before you shaped Winchester and passed it to you.

You will leave your mark then pass it on to future generations.



"We do not only inhabit space, we also dwell in time."

J M Goldson

community preservation
+ planning

PROJECT TEAM: JM GOLDSON
RKG ASSOCIATES INC, TOOLE DESIGN
GROUP, BOB MITCHELL FAICP

**Text "JMGOLDSON" to 22333
to join
OR
Go to pollev.com/jmgoldson**

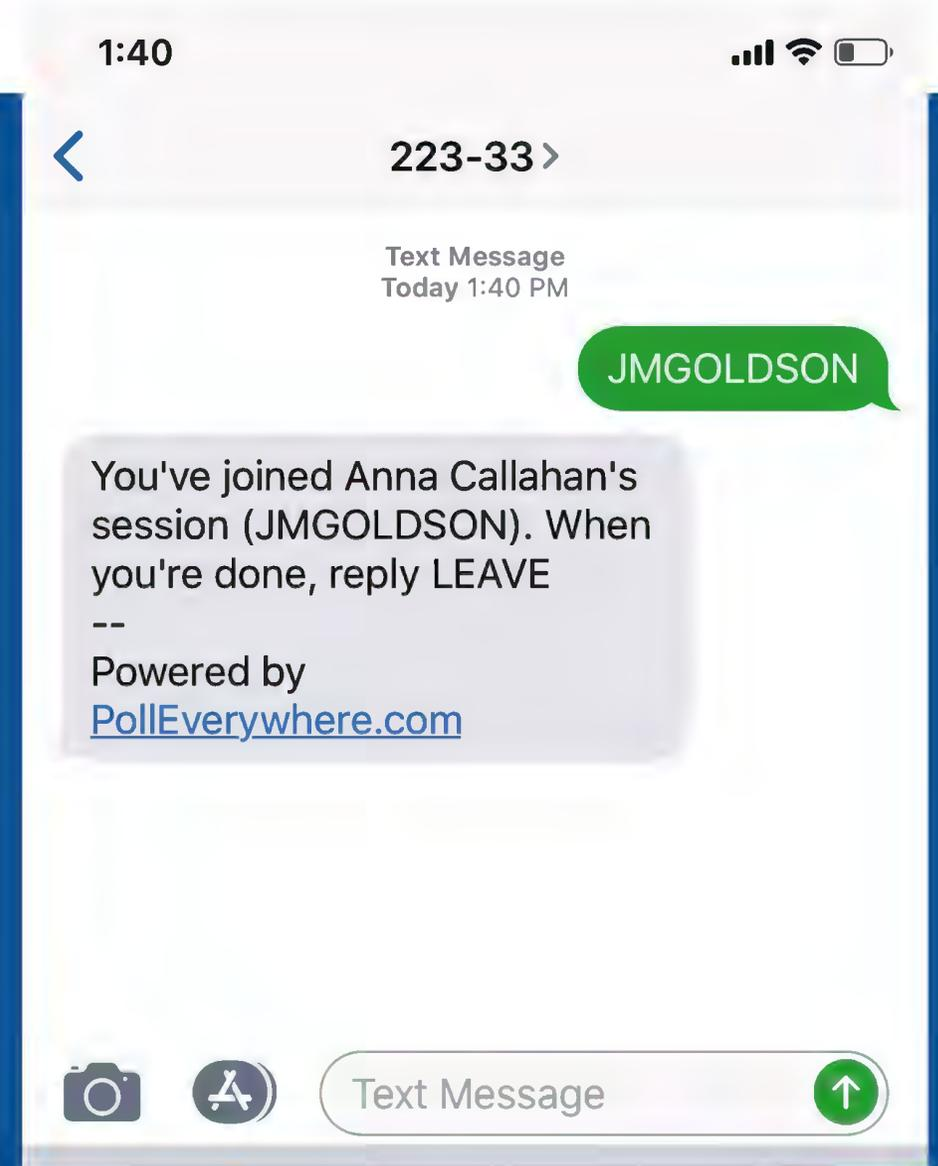

How long have you lived, worked in or otherwise been associated with Winchester?

 **Poll locked.** Responses not accepted.

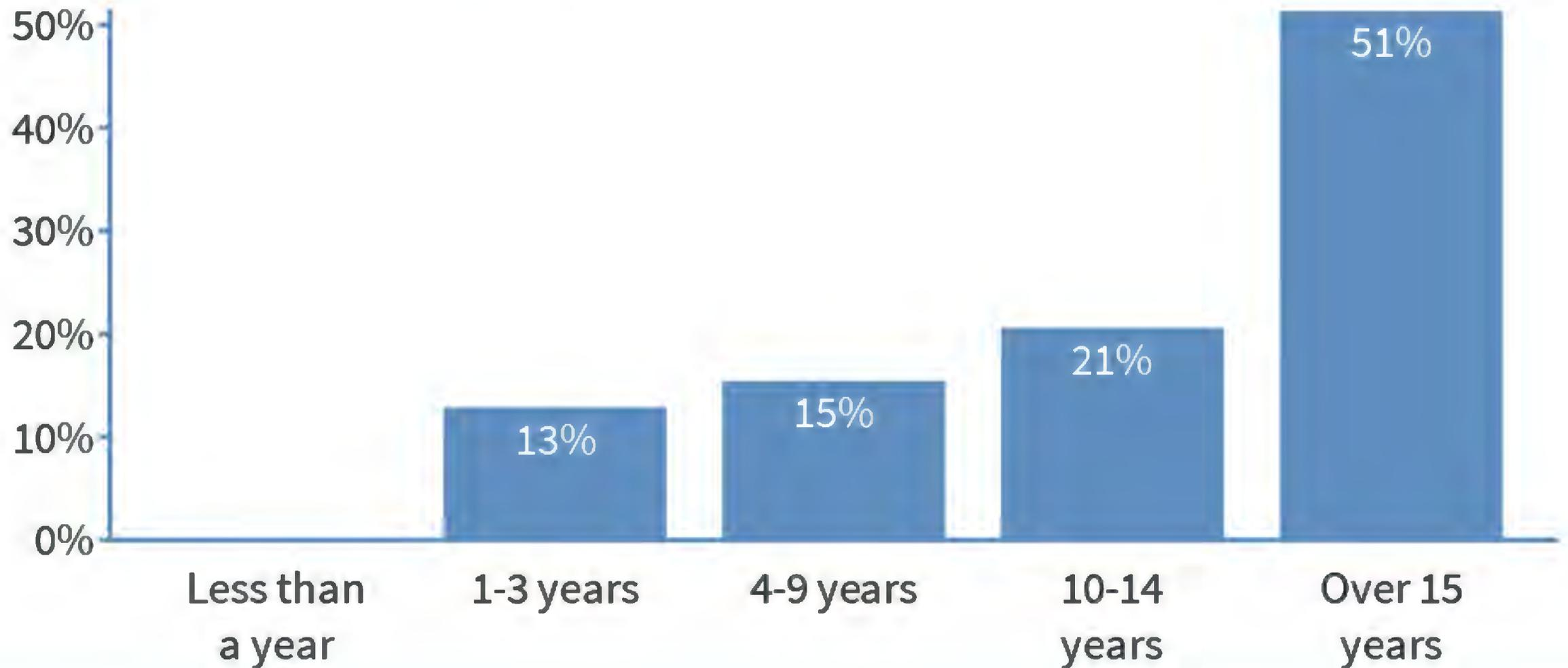

What have we learned so far??

Population trends

Population Growth 2010-2017

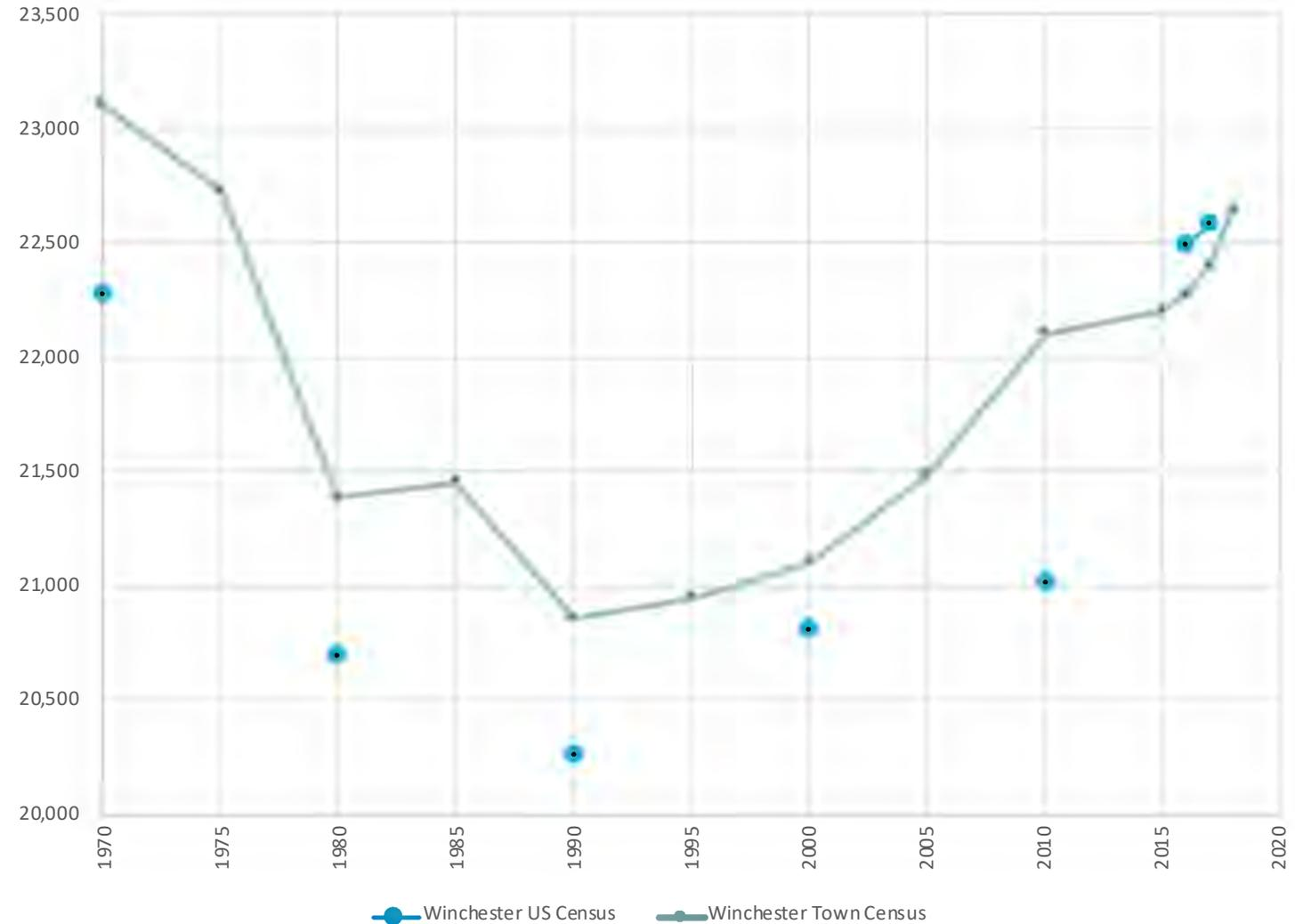
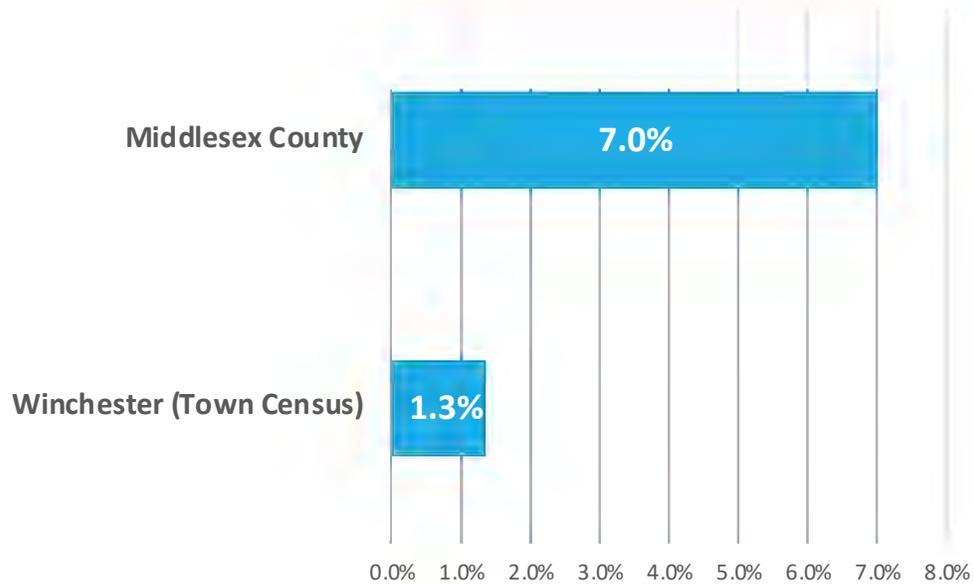

Source: US Census, 2012-2017 ACS, and Winchester Town Census

Household composition

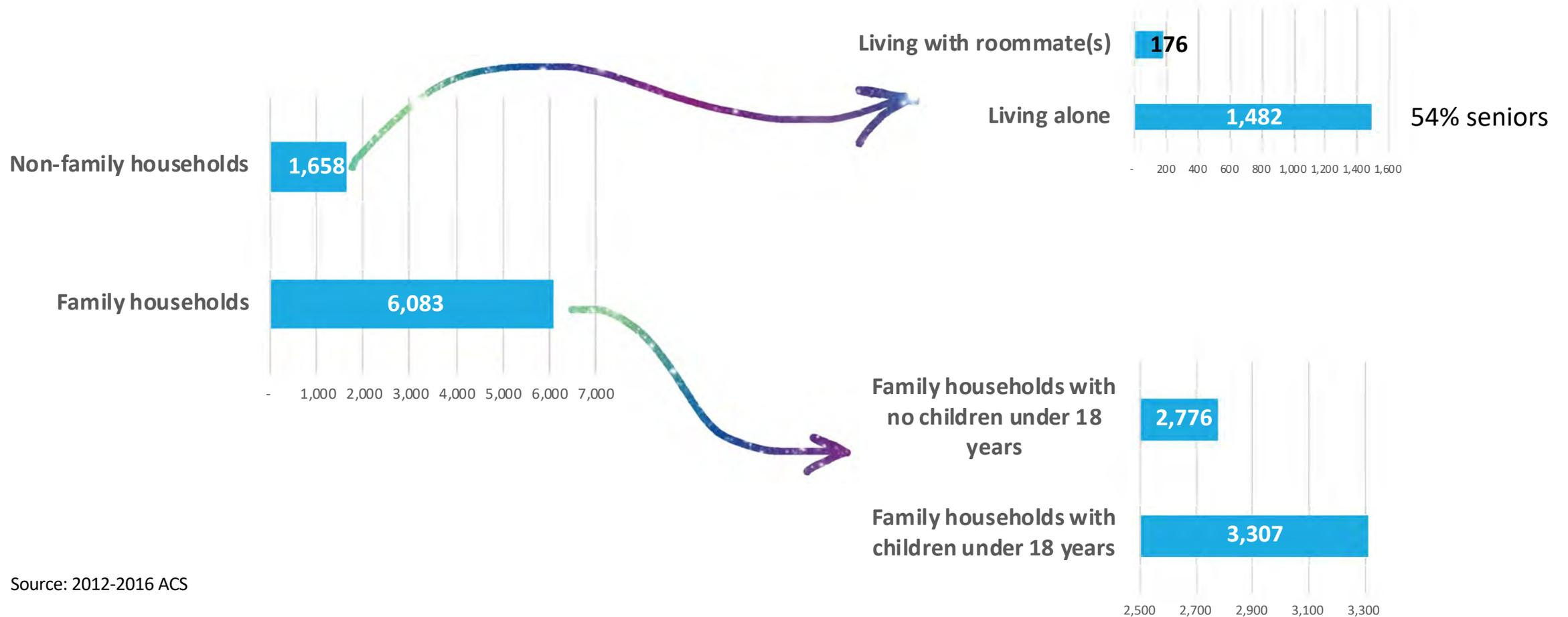

Where people work & how they get there

- **91%** of working residents travel outside of town for work
- **9%** live and work in Winchester
- # of jobs in Winchester has decreased about **7%**
- People driving alone make up over **70%** of commuting traffic
(adding about 7,000 cars to the roads during commuting hours).



What have we learned so far??

Income

City/town	Median annual household income
Dover	\$204,018
Weston	\$196,651
Wellesley	\$176,852
Sudbury	\$170,945
Sherborn	\$170,872
Carlisle	\$170,703
Wayland	\$166,893
Lexington	\$162,083
Boxford	\$155,034
Medfield	\$153,847
Winchester	\$152,196
Bolton	\$151,618
Hopkinton	\$151,357
Westwood	\$145,799

Figure 9 Winchester Median Income by Household Type, 2016

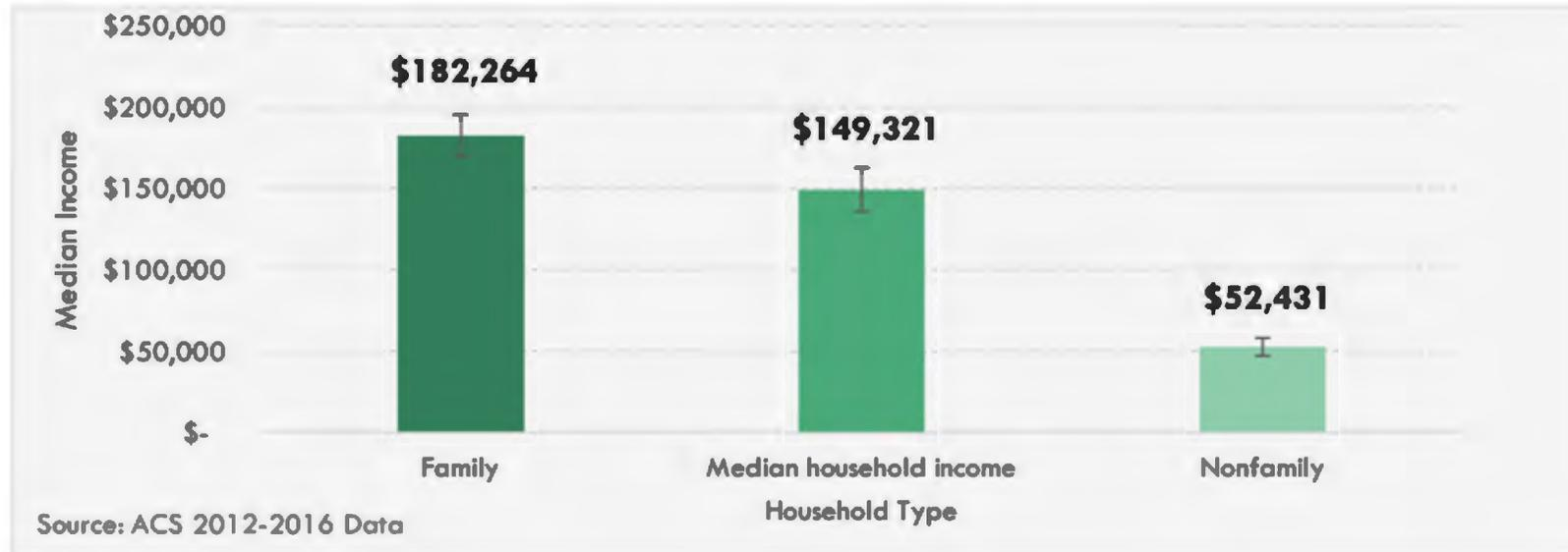

About **1,405** Winchester households are estimated to have low/moderate income.*

That's about **18%** of total households (7,741).

Low/moderate income = 80% of the Area Median Income (e.g., one-person household with income at or below \$56,800 and a four-person household at or below \$81,100).

Source: 2012-2016 ACS, as reported in the Winchester Housing Production Plan, 2018.

Home prices

In the top 11 in the region with highest price appreciation since the recession for single-family
(2017 prices were 47% higher than 2005)

In the top 5 for condo appreciation
(73% higher than 2005)

2018 Median Sales Price for all units:
\$975,000



Tax Base

**Average Property Tax Bill (FY2017):
\$11,946**

**To shift the commercial tax base 1%,
would require 360,000 sf of new
commercial development**
(at an average assessed value of \$200 per square feet).

**That's 24% of the total sf of
commercial space in Winchester.**

Use	Building Area (SF)
Residential	20,732,721
Commercial	1,472,571
Tax-Exempt	1,593,580
Total	23,798,872

"Prediction is very difficult, especially if it's about the future."



Predicted by 2030, individuals will cease to have permanent jobs, with most people becoming freelancers, as part of the so-called gig economy.



New job titles predicted to be widespread in 2030:

- Alternative Vehicle Developer
- Avatar Manager / Devotee
- Body Part Maker
- Climate Change Reversal Specialist
- Memory Augmentation Surgeon

What are we doing tonight?

- 1. Visioning: Imagine what your community could be at its very best.**
- 2. Goals: Identify main issues you hope this plan can address.**

Other ways you can stay involved

Tabling
Events

coUrbanize

DIY Meeting
Kit

MAP INFO UPDATES TIMELINE

Winchester Master Plan 2030

WINCHESTER, MA

Comment on the map

★ Follow

➦ Share

Sort by:

Newest

Category:

All



Laura Rollins

Jan 22, 2019

This entry into the rotary should have a stop sign. The traffic from this direction rarely yields, let alone slows down to enter the rotary. It is the most dangerous point of a very dangerous intersection.... [Read more](#)

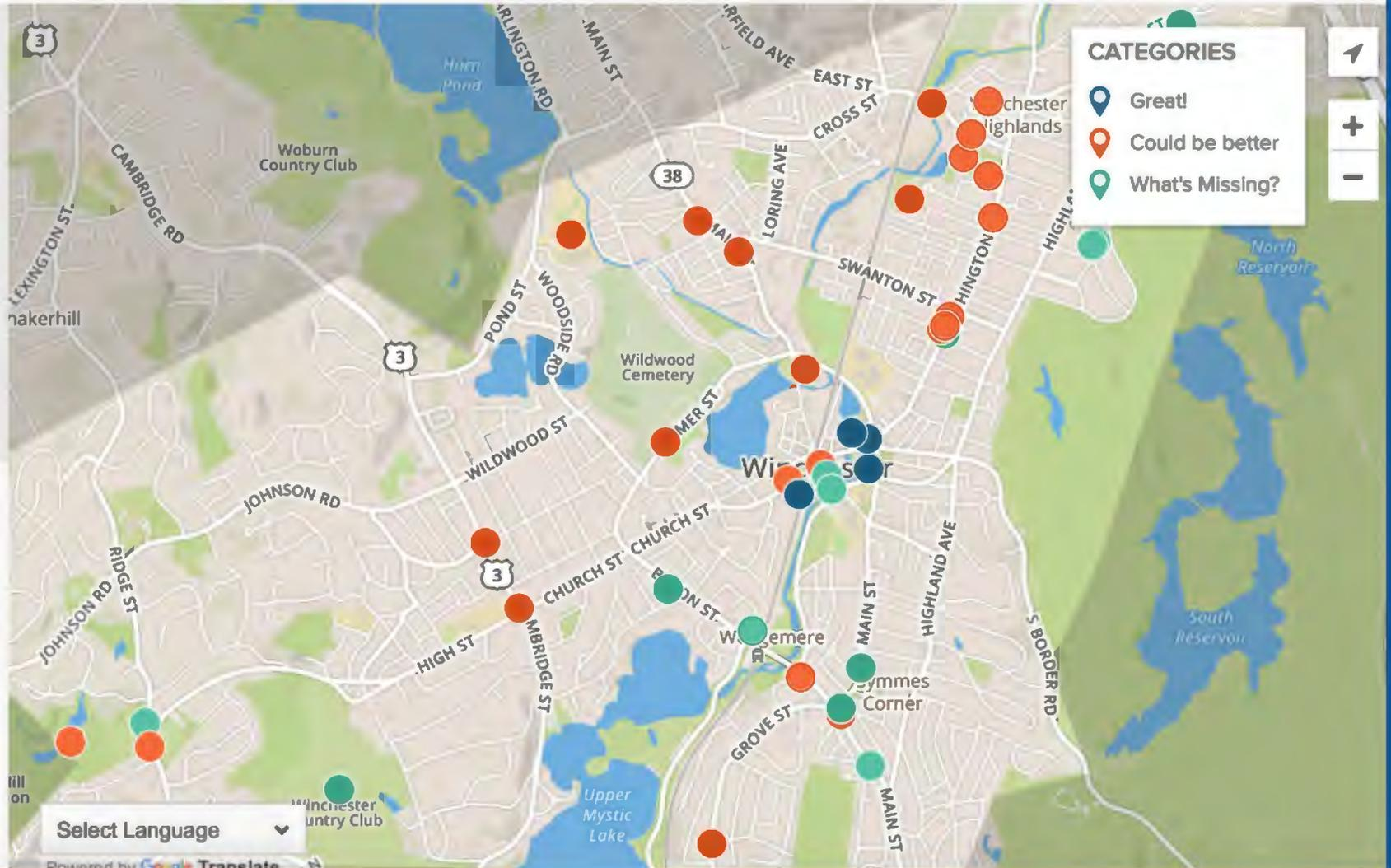

CATEGORIES

- Great!
- Could be better
- What's Missing?



Select Language

Powered by Google Translate

Envision Winchester's Future: Discussion Exercises

Anna Callahan

In 2030, I will be _____ years old. (hint: add 11 years to your current age)

 **Poll locked.** Responses not accepted.

“80” “62” “76” “95” “Walkable” “76” “Primosunset617” “75” “+73” “61” “61”

“85” “Walkable” “57” “67” “78” “68” “51” “39 again” “75” “63” “95” “64”

“Still affluent” “81” “Staceyirizar327” “1000” “54” “49” “64” “STACEYIRIZAR327” “55”

“76” “50” “Fells” “50” “78” “71” “Similar to today but more shopping options downtown.” “72”

“Volunteers” “Staceyirizar327” “59” “Hospital” “73” “Architecture, historic architecture,” “63”

“78” “53” “75” “Hospital” “52” “90” “19” “75” “Diverse” “60” “50” “70”

“Pretty much the same” “PRIMOSUNSET617”

In 2030, I imagine Winchester will be

J M Goldson

community preservation
+ planning

PROJECT TEAM: JM GOLDSON
RKG ASSOCIATES INC, TOOLE DESIGN
GROUP, BOB MITCHELL FAICP

**What are your biggest concerns about the future in
Winchester?**

J M Goldson

community preservation
+ planning

PROJECT TEAM: JM GOLDSON
RKG ASSOCIATES INC, TOOLE DESIGN
GROUP, BOB MITCHELL FAICP

Wrap Up & Next Steps

Tabling
Events

coUrbanize

DIY Meeting
Kit