

Combustible Gas Leak Detector

#LSCG

The LSCG Leak-Seeker™ is a hand-held, battery operated combustible gas leak detector **for use by HVAC Pros, Plumbers, Pipefitters, Mechanical Contractors, Facility Maintenance, Factory Technicians, and other professional trades** for installing or servicing equipment that uses combustible gas on residential, commercial, or light industrial jobs.

A key benefit of the LSCG is that it has **5 different alarms to help technicians quickly pinpoint leaks**. For example, **3 different visual alarms** show "gas concentration" on the large backlit display, while **one vibration alarm** and **one audible alarm** alert technicians when working in challenging jobsite conditions. **Other key features/benefits include:**

- **Detects Up To 30 Combustible Gases** - Best in its class! (See reverse for full list).
- **Large Backlit LCD Display** - 1.5" x 2" (38 x 51mm) largest in its class! **Visual alarms include:**
 - **Speedometer PPM Scale** - Great for peripheral vision while searching for leaks.
 - **PPM Readout** - Large ½" numbers are more precise than detectors that show ranges.
 - **LEL % Readout** - Large ½" numbers show what % of the lowest gas concentration that has the potential to be flammable or combustible.
- **High/Low Concentration Key** - For detecting 10 to 1,000 PPM or 100 to 10,000 PPM.
- **Long 20" (51 cm) Flexible Probe** - For hard-to-reach areas.
- **Ergonomic Housing with Intuitive Keypad** - Simple icons or abbreviations
- **Auto Features (AC, APO, AZ)** - Automatic Calibration at each power up; Auto Power Off if not used for 10 minutes; Auto Zero- resets the sensor.
- **Rechargeable Lithium-Ion Battery** - No need to buy or dispose of single-use batteries.



LCD SCREEN (Shown Full Size)

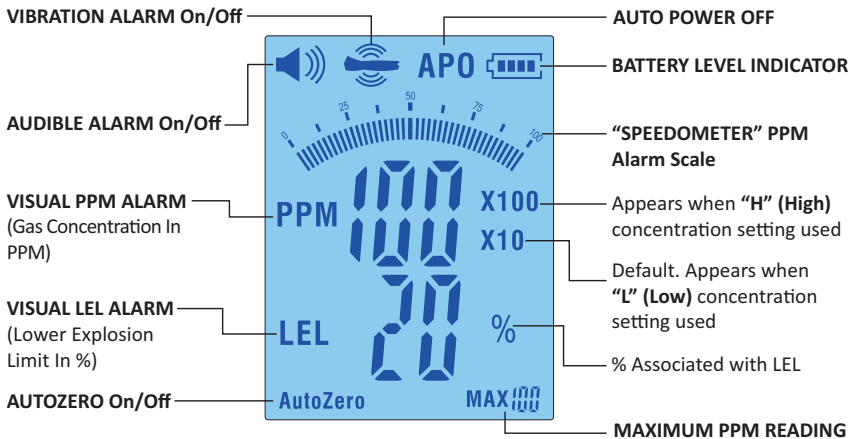

CPS Global Headquarters

3600 Enterprise Way | Miramar, FL 33025 USA cpsproducts.com
 For more information call: In the U.S.A. (800) 277-3808 or (305) 687-4121
 In Canada (905) 358-3124 In Europe 323 281 30 40 In Australia 61 8 8340 7055

Connect with us on social media



CPS reserves the right to make changes to, or discontinue any product or service identified in this publication without notice. CPS advises its customers to ensure they have obtained the latest and most current version of any relevant information before placing any orders. © CPS Products, Inc. All rights reserved.

Product Specifications

ALARMS FOR PINPOINTING LEAKS

Visual Alarms (Gas Concentrations)	1) Large, EZ-Read PPM number (Constant ON)
	2) Analog PPM "Speedometer" Scale (Constant ON)
	3) Large EZ-Read Digital Lower Explosive Limit % Value (Constant ON)
Audible Alarm	4) Loud 85dB beep. Frequency proportional to gas concentration. Dedicated On/Off Key
Vibration Alarm	5) Vibration frequency proportional to gas concentration. Dedicated On/Off Key

SENSOR

Warm Up Time	40 seconds (display counts down each time device turned on)
Auto Calibration	Each time device turned on
Gas Response Time	<2 seconds
Sensor Type	Heated Tin Oxide (Included). Replacements available from CPS

GASES DETECTED

Detects Up To 30 Combustible Gases	Natural Gas (Methane, Ethane, Propane, Butane), and Acetylene, Acetone, Acetaldehyde, Ammonia, Benzene, CO, Denatured Alcohol, Ethanol, Ethylene, Formaldehyde, Gasoline, Hexane, Hydrogen, Hydrogen Sulfide, Isobutane, Isopropanol, Isopropyl Alcohol, Kerosene, Methanol, MEK, Mineral Spirits, Naptha, Paint Thinner, Paraxylene, Toluene, Xylene
Gas Sensitivity	<10 PPM (at X10 concentration)

DISPLAY

Type, Size	Large 1.5" x 2" (38 x 51mm) LCD with backlight (On/Off key)
Lowest PPM Reading On Display	10 PPM (When Using X10 LOW Concentration Setting) 100 PPM (When Using X100 HIGH Concentration Setting)
Highest PPM (LEL Readout)	10,000 PPM (20% of the LEL for Methane)
LEL (Lower Explosion Limit)- % Range	0% to 20%
Auto Power Off (APO Key)	Low power auto shutdown, auto off after 10 minutes of no use to conserve power

BATTERY, CHARGER, RUN TIME

Battery Type	Polymer Lithium-Ion, 3.7V DC, Hardwired
Full Charge Time	2.5 Hours
Battery Charger (Configuration)	Plug: (Input: AC 100V-240V, 2 Prong Power Adapter); (Output: 5V, 1A); USB Cord: 7 Ft (2.08 m)
Maximum Run Time After Full Charge	8 Hours

ENVIRONMENTAL

Operating Temperature Range	32°F To 104°F (0°C To 40°C)
Operating Humidity Range	0 To 85% RH
Storage Temperature Range	14°F To 140°F (-10°C To 60° C)

PRODUCT

Concentration Key	Low Or High Settings. Low: 10 to 1,000 PPM in 10 PPM increments. High: 100 to 10,000 in 100 PPM increments.
Flexible Probe	Vinyl coated, 20" (51 cm) length
Weight (Without Packaging)	0.92 Lb (0.41 kg)
Housing Size (H x W x D)	8.1" x 2.4" x 1.7" (20.6 x 6.0 x 4.3 cm)
Warranty	1 Year

STANDARDS

Relevant Standards	EN 50270:2105; EN 61000-6-3:2007+A1:2011; EMC Directive 2014/30/EU
--------------------	--

Packaging	Size H x W x D, Inches (cm)	UPC #	Net Weight	Gross Weight, Lb (kg)	Quantity Of LSCG's
Individual Box 4 color print. Hang tab style	12.9" x 5.5" x 2.5" (32.7 x 13.9 x 6.4 cm)	7 50377 12058 9	1.3 Lb (0.59 kg)	1.3 Lb (0.59 kg)	1
Shipping Box	13.6" x 23.6" x 11.8" (34.5 x 60 x 30cm)	7 50377 12058 948	29.8 Lb (13.5 Kg)	32 Lb (14.5 Kg)	20

Includes Storage Case, AC Plug, USB Cord, Quick Start Guide

