

# **CROSLEY**

---

FURNITURE

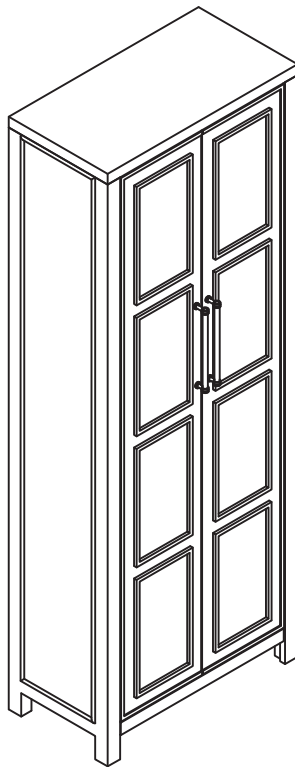



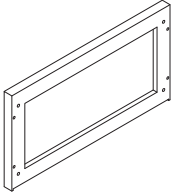
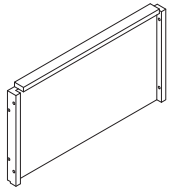
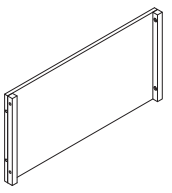
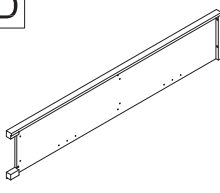
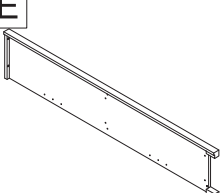
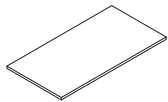
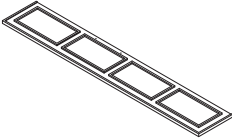
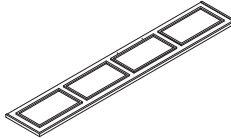
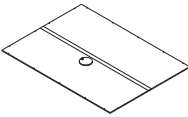
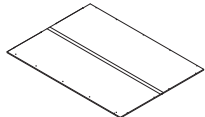

## Storage Pantry CF3135

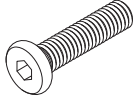
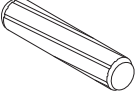
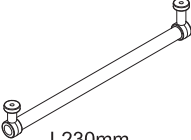

# PART LIST

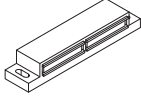
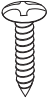
				
<p>Top Panel 1 PC</p>	<p>Bottom Panel 1 PC</p>	<p>Fixed Shelf 1 PC</p>	<p>Left Panel 1 PC</p>	<p>Right Panel 1 PC</p>
				
<p>Adjustable Shelf 2 PCS</p>	<p>Left Door 1 PC</p>	<p>Right Door 1 PC</p>	<p>Upper Back Panel 1 PC</p>	<p>Lower Back Panel 1 PC</p>

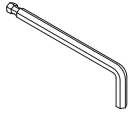
# HARDWARE LIST

 <p>Ø1/4"x25mm</p>	 <p>Ø8*30mm</p>	 <p>L230mm</p>	 <p>Ø4*19mm</p>	
<p>Bolt 12 PCS (Extra 1)</p>	<p>Wood Dowel 12 PCS (Extra 1)</p>	<p>Handle 2 PCS</p>	<p>Round Head Bolt 4 PCS (Extra 1)</p>	<p>Shelf Holder 8 PCS (Extra 1)</p>
	 <p>Ø3*16mm</p>	 <p>Ø3*16mm</p>	 <p>Ø3*14mm</p>	
<p>Double Magnet 2 PCS</p>	<p>Long Screw 4 PCS (Extra 1)</p>	<p>Round Head Screw 28 PCS (Extra 1)</p>	<p>Short Screw 12 PCS (Extra 1)</p>	<p>Allen Wrench 1 PC</p>
 <p>Safety Strap Kit 1 SET</p>				

## ADDITIONAL TOOLS (Not Provided)

Note: It is not recommended to use power tools during assembly.

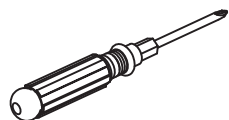

Phillips Head Screwdriver

Note: Wood dowels are intended for alignment. Additional clearance between wood dowel and pre-drilled hole is intentional for ease of assembly.

Step 1. Attach double magnets (part #6) to top panel (part A) and bottom panel (part B) using long screws (part #7) and phillips head screwdriver.

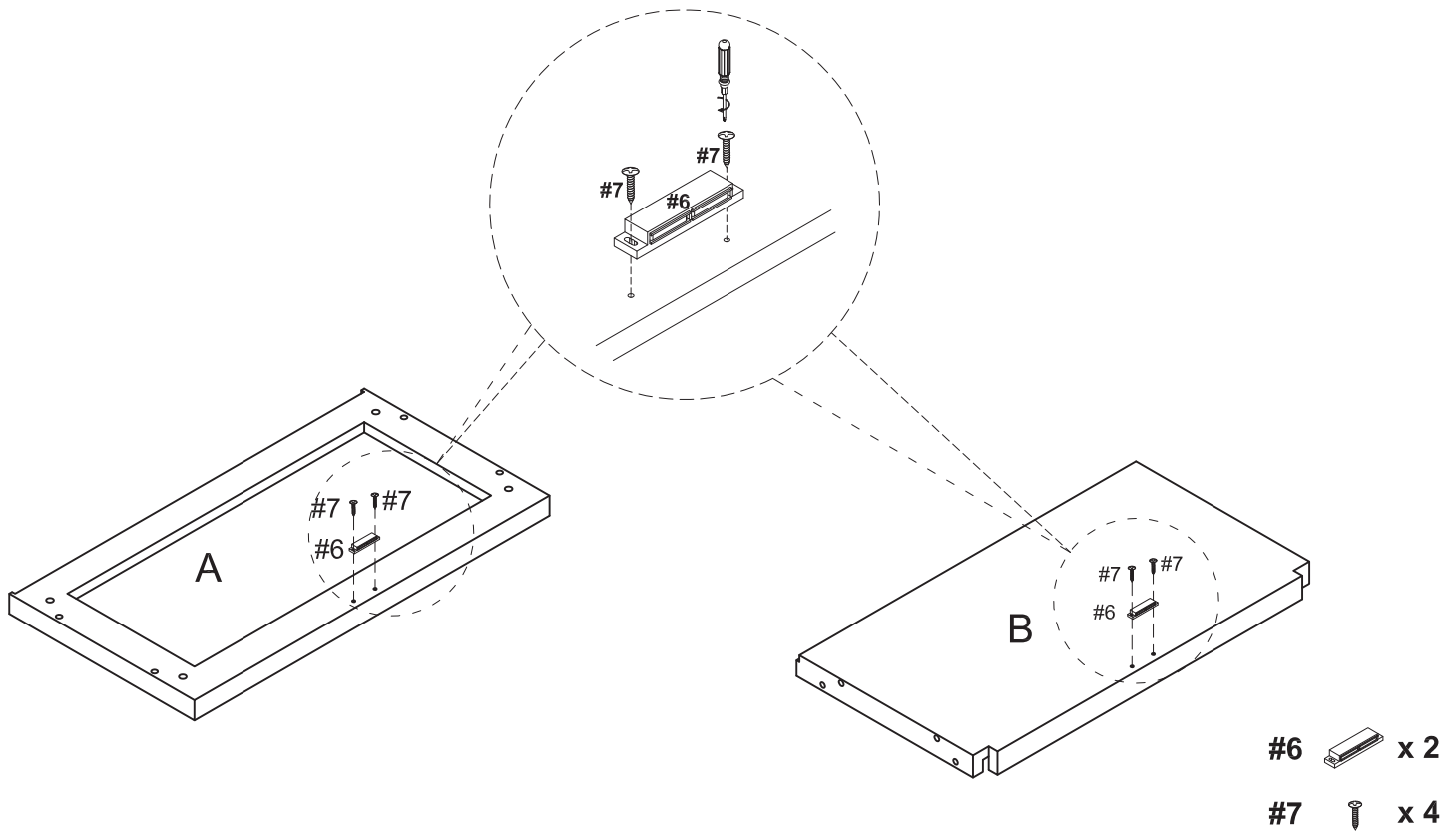

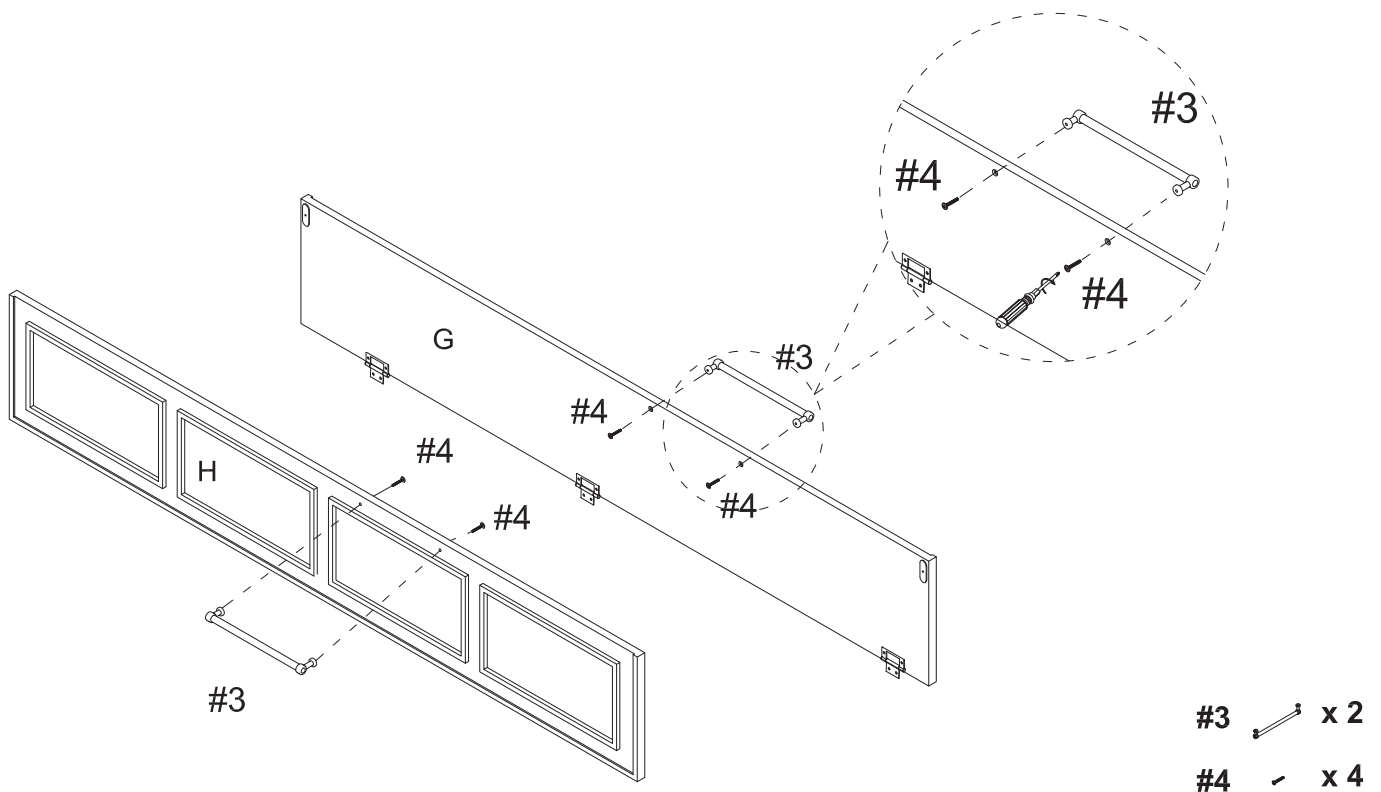

Step 2. Attach handles (part #3) to doors (parts G & H) using round head bolts (part #4) and phillips head screwdriver.



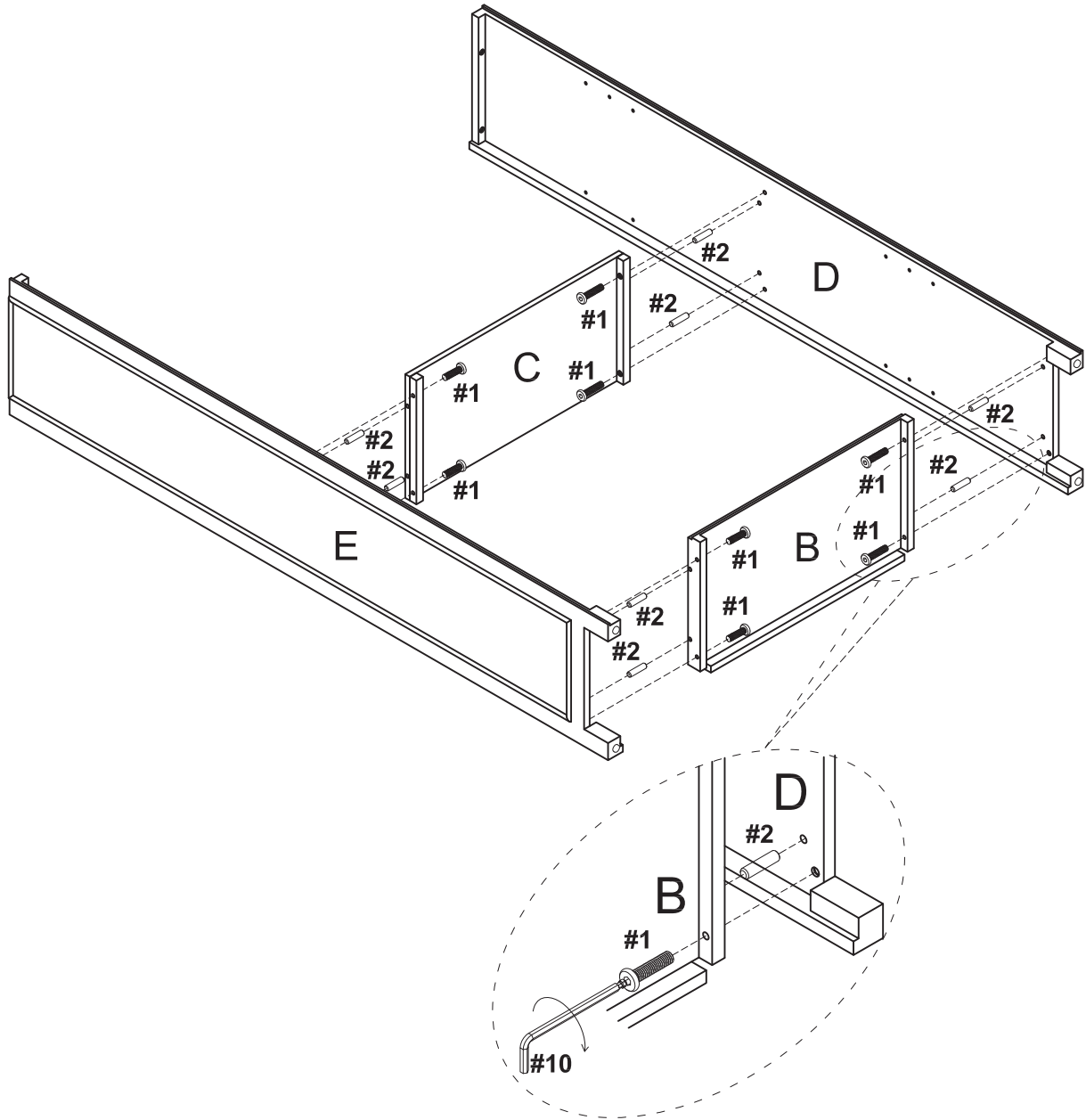



Step 3. Attach panels (parts D & E) to bottom panel (part B) and fixed shelf (part C) using bolts (part #1), wood dowels (part #2) and allen wrench (part #10).

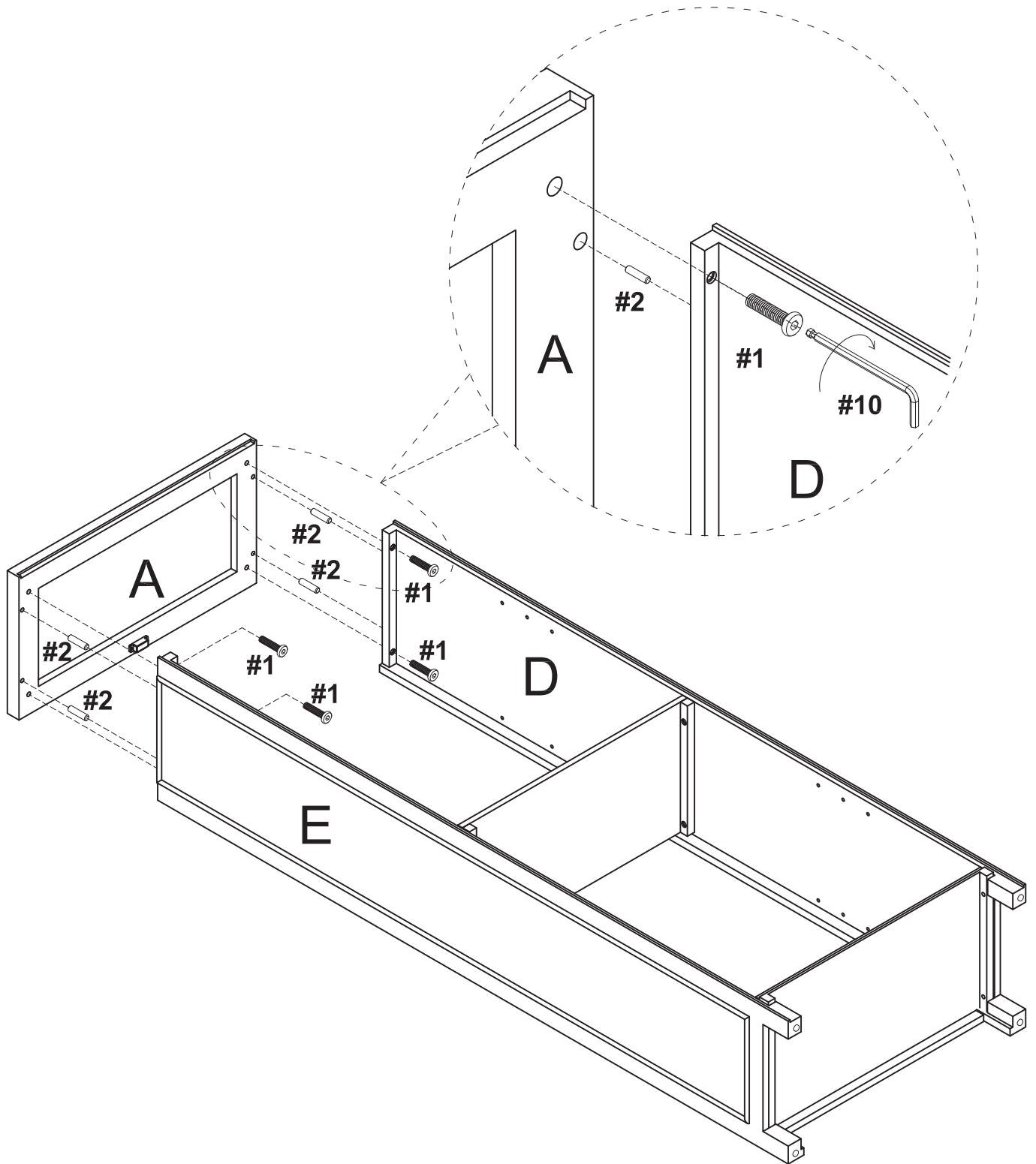

- |     |   |     |
|-----|---|-----|
| #1  |  | x 8 |
| #2  |  | x 8 |
| #10 |  | x 1 |

Step 4. Attach top panel (part A) to assembled unit (parts D & E) using bolts (part #1), wood dowels (part #2) and allen wrench (part #10).



- |     |   |     |
|-----|---|-----|
| #1  |  | x 4 |
| #2  |  | x 4 |
| #10 |  | x 1 |

Step 5. Attach back panels (parts I & J) to assembled unit (parts A, B, C, D & E) using round head screws (part #8) and phillips head screwdriver.

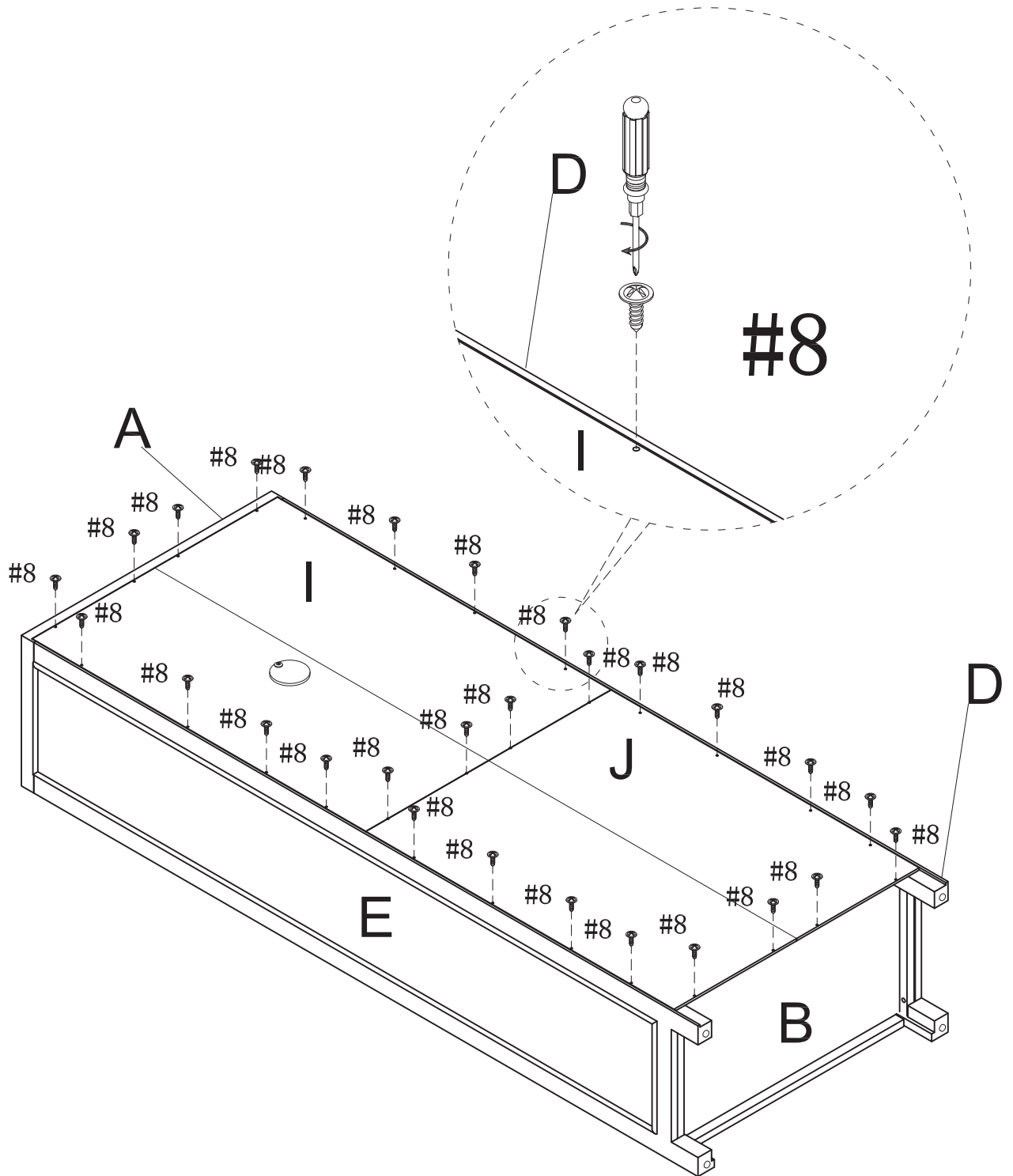

#8  x 28

Step 6. Carefully turn unit upright. Place shelf holders (part #5) into desired position and slide adjustable shelves (part F) into place.

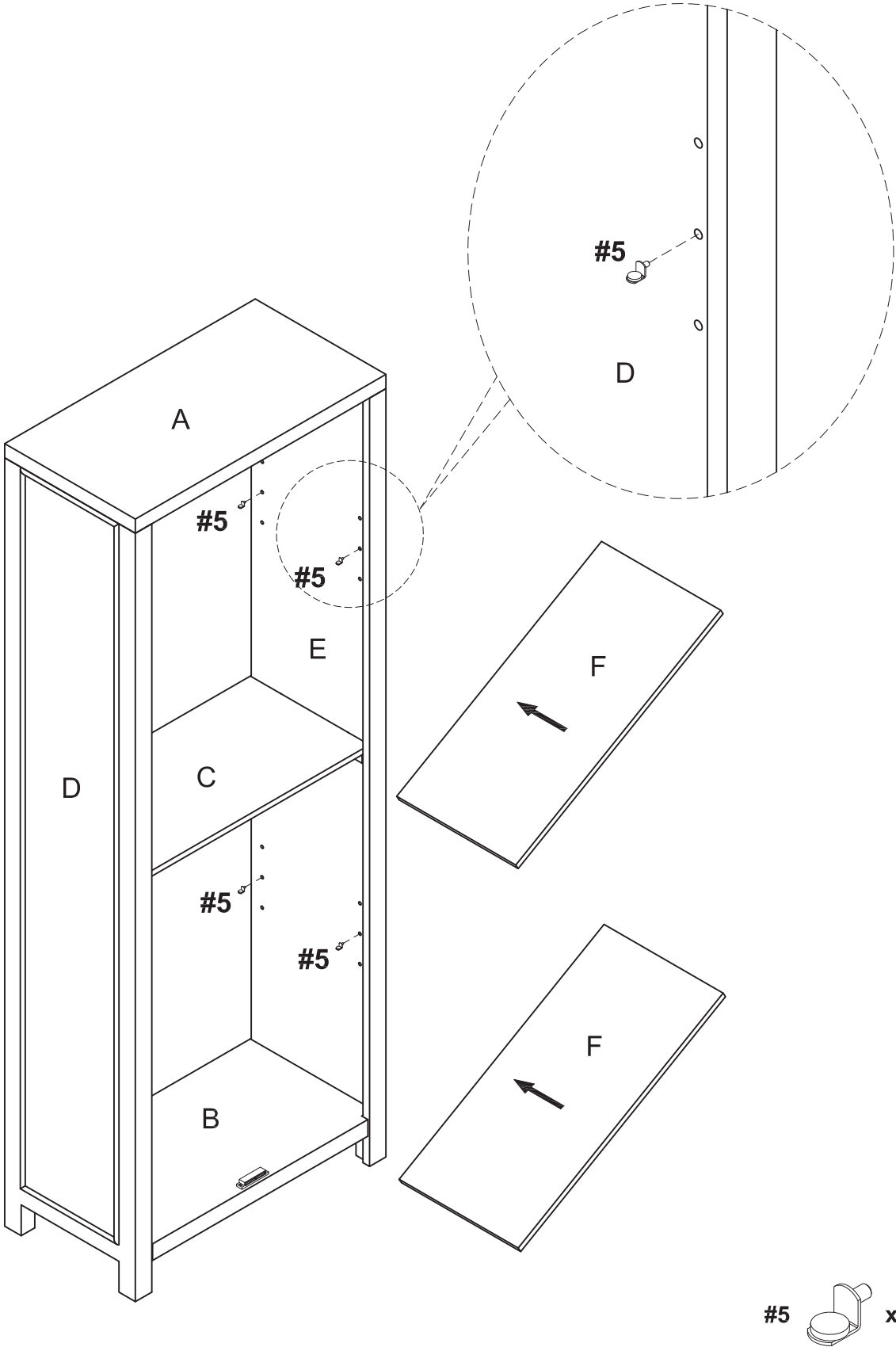

Step 7. Attach doors (parts G & H) to assembled unit (parts D & E) using short screws (part #9) and phillips head screwdriver.





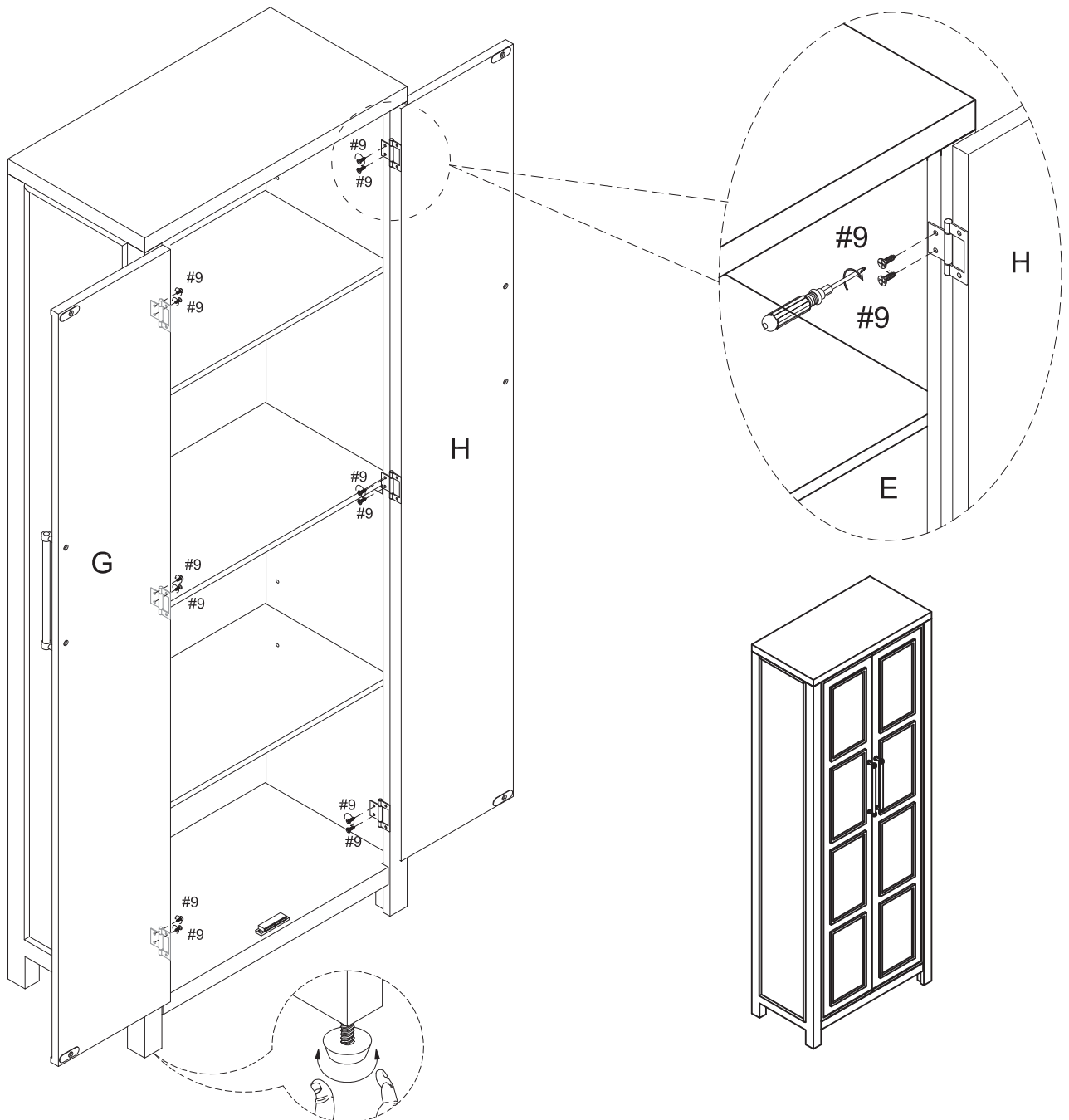

Note: It is important to adjust levelers once fully assembled and upright. Extend adjustable leveler until it's firmly in contact with the floor.

If relocating, adjust leveler as needed until it's firmly in contact with the floor in new location.

Important: Safety strap kit (part #11) must be installed to prevent tipping damage and/or injury.



#9  x 12

#11	A	B	C	D	E
	 1-1/2"xΦ4xD8	 1 PC	 5/8"xΦ3xD8	 1 PC	 1 PC
Safety Strap Kit 1 SET	Long Screw 1 PC	Wall Anchor 1 PC	Short Screw 1 PC	Safety Wall Strap 1 PC	Flat Washer 1 PC

### SAFETY WALL STRAP INSTALLATION

Note: It is highly recommended to install this safety strap kit to prevent tipping, damage and/or injury.

1. Insert short screw (C) through flat washer (E) and safety wall strap (D) and attach to top panel (part A) using phillips head screwdriver.
2. Drill a 11/32" hole where you want to secure the unit. The drilled hole will be at the same height as the hole in top panel (part A) where safety wall strap (D) is attached. Tap wall anchor (B) into the hole.
3. Insert long screw (A) through safety wall strap (D) into wall anchor (B) using phillips head screwdriver.

Note: This item is not intended for clothing storage use.

