

# **CROSLEY**

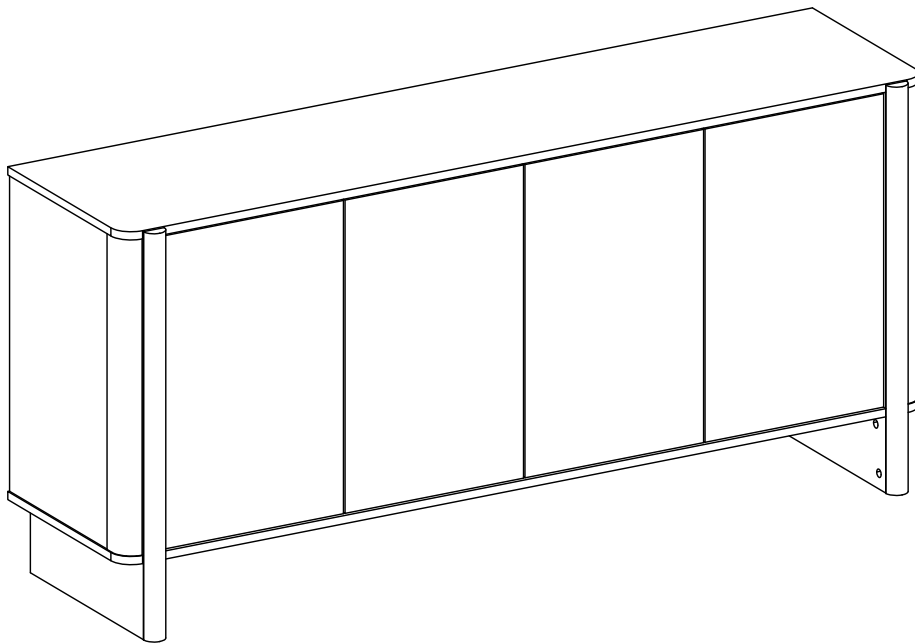









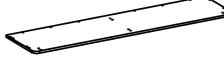
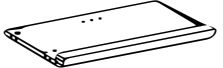

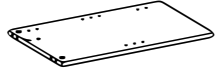

---

FURNITURE



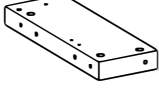
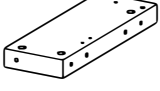











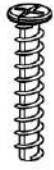

## Sideboard CF4225

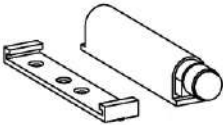

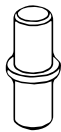
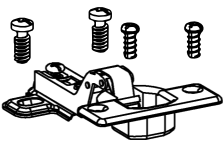
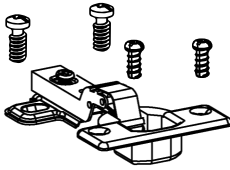
# PART LIST

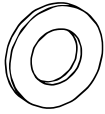
<p><b>A</b></p> 	<p><b>B</b></p> 	<p><b>C</b></p> 	<p><b>D</b></p> 	<p><b>E</b></p> 
<p>Top Panel 1 PC</p>	<p>Bottom Panel 1 PC</p>	<p>Left Panel 1 PC</p>	<p>Right Panel 1 PC</p>	<p>Partition Panel 1 PC</p>
<p><b>F</b></p> 	<p><b>G</b></p> 	<p><b>H</b></p> 	<p><b>I</b></p> 	<p><b>J</b></p> 
<p>Top Support 2 PCS</p>	<p>Pillar 2 PCS</p>	<p>Top Rear Panel 1 PC</p>	<p>Bottom Rear Panel 1 PC</p>	<p>Pillar Support 2 PCS</p>
<p><b>K</b></p> 	<p><b>L</b></p> 	<p><b>M</b></p> 	<p><b>N</b></p> 	<p><b>O</b></p> 
<p>Adjustable Shelf 2 PCS</p>	<p>Bottom Middle Support 1 PC</p>	<p>Bottom Left Support 1 PC</p>	<p>Bottom Right Support 1 PC</p>	<p>Door 4 PCS</p>
<p><b>P</b></p> 	<p><b>Q</b></p> 			
<p>Cover 4 PCS</p>	<p>Metal Support 1 PC</p>			

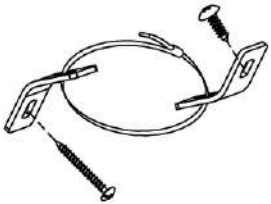
# HARDWARE LIST

<p><b>#1</b></p> 	<p><b>#2</b></p> 	<p><b>#3</b></p> 	<p><b>#4</b></p> 	<p><b>#5</b></p>  <p>10 x 33.5 mm</p>
<p>Cam Lock 42 PCS (Extra 1)</p>	<p>Cam Bolt 42 PCS (Extra 1)</p>	<p>Cam Sticker 42 PCS (Extra 1)</p>	<p>Plastic Dowel 55 PCS (Extra 1)</p>	<p>Confirmat Screw 10 PCS (Extra 1)</p>
<p><b>#6</b></p>  <p>6 x 45 mm</p>	<p><b>#7</b></p>  <p>6 x 8 mm</p>	<p><b>#8</b></p>  <p>4 x 10 mm</p>	<p><b>#9</b></p> 	<p><b>#10</b></p> 
<p>Bolt 4 PCS (Extra 1)</p>	<p>Euro Screw 8 PCS (Extra 1)</p>	<p>Varianta Screw 4 PCS (Extra 1)</p>	<p>Push To Open 4 PCS</p>	<p>Spring Washer 4 PCS (Extra 1)</p>
<p><b>#11</b></p> 	<p><b>#12</b></p> 	<p><b>#13</b></p> 	<p><b>#14</b></p> 	<p><b>#15</b></p> 
<p>Shelf Pin 8 PCS (Extra 1)</p>	<p>Full Curve Hinge 4 PCS</p>	<p>Half Curve Hinge 4 PCS</p>	<p>Allen Key 1 PC</p>	<p>Flat Washer 4 PCS (Extra 1)</p>
<p><b>#16</b></p> 	<p><b>#17</b></p> 		<p><b>#18</b></p> 	
<p>Binding Post 4 SETS (Extra 1)</p>	<p>Safety Strap Kit 1 SET</p>		<p>Wall Anchor 1 PC</p>	

## ADDITIONAL TOOLS (not Provided)

NOTE: It is not recommended to use power tools during assembly



Phillips Head Screwdriver

NOTE: Lay all parts on a soft surface, such as carpet to assemble unit.

NOTE: Plastic dowels are intended for alignment. Additional clearance between plastic dowel and pre-drilled hole is intentional for ease of assembly.

IMPORTANT NOTE: WE RECOMMEND AT LEAST TWO PEOPLE WORK TOGETHER TO ASSEMBLE UNIT.

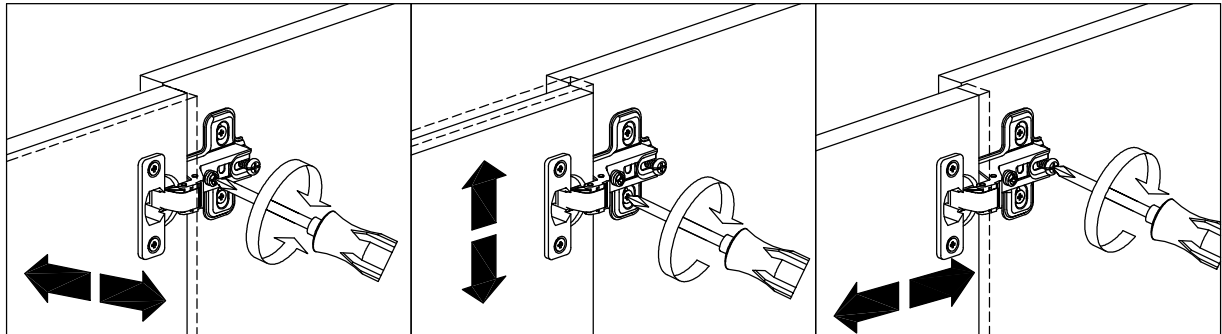

Please adjust hinges as needed for proper door alignment.

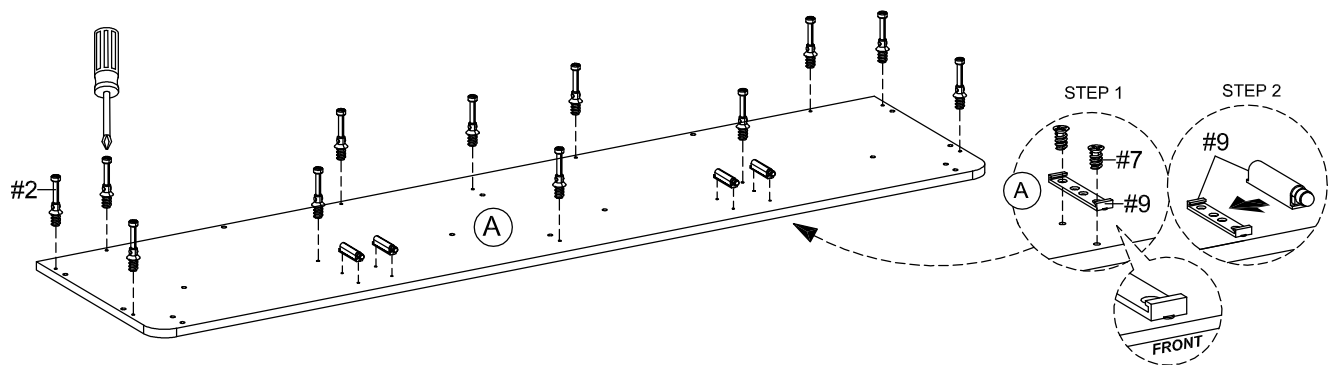

Step 1. Screw cam bolts (part #2) into top panel (part A) using phillips head screwdriver. Attach push to opens (part #9) to top panel (part A) using euro screws (part #7) and phillips head screwdriver.

Note: Do not overtighten cam bolts. Stop tightening once threads on cam bolt are no longer visible.





#2		x 12
#7		x 8
#9		x 4

Step 2. Screw cam bolts (part #2) into bottom panel (part B) using phillips head screwdriver. Insert cam locks (part #1) and plastic dowels (part #4) in to pillar (part G).

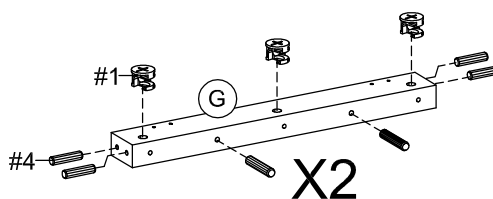
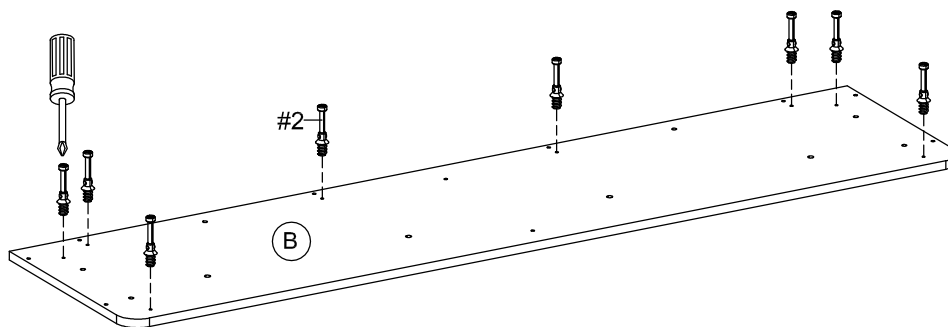
Note: Do not overtighten cam bolts. Stop tightening once threads on cam bolt are no longer visible.





#1		x 6
#2		x 8
#4		x 12

Step 3. Screw cam bolts (part #2) into left panel (part C) and right panel (part D) using phillips head screwdriver. Insert cam locks (part #1) and plastic dowels (part #4) into left panel (part C) and right panel (part D).

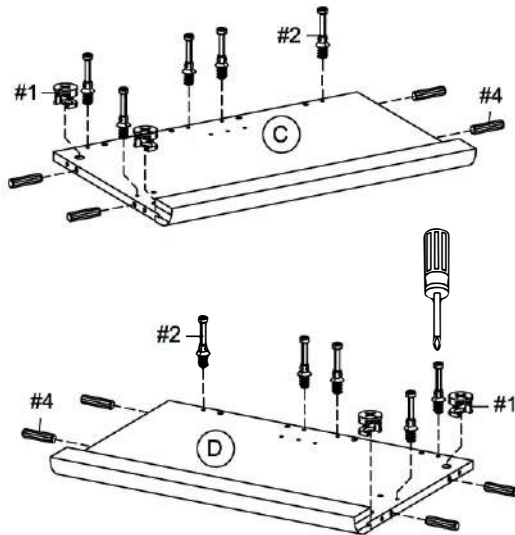



Note: Do not overtighten cam bolts. Stop tightening once threads on cam bolt are no longer visible.

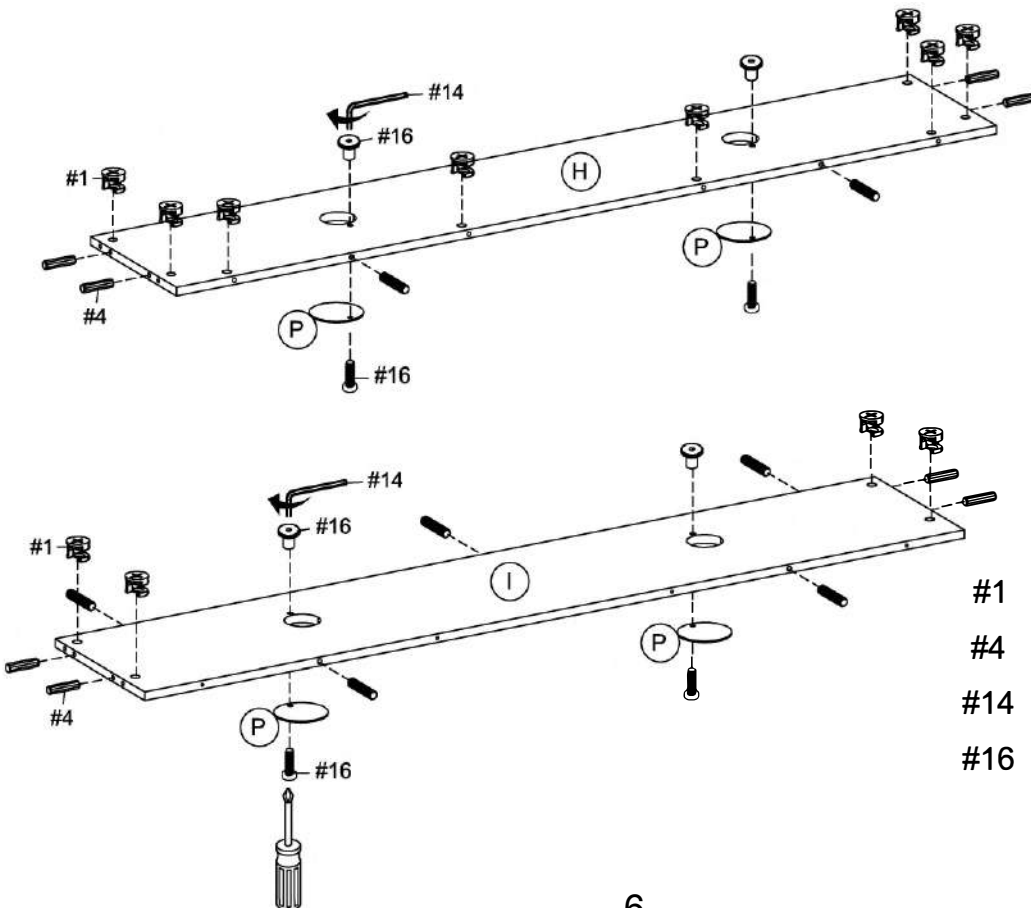

- |    |   |      |
|----|---|------|
| #1 |  | x 4  |
| #2 |  | x 10 |
| #4 |  | x 8  |

Step 4. Attach covers (part P) to rear panels (parts H & I) using binding posts (part #16), allen key (part #14) and phillips head screwdriver. Insert cam locks (part #1) and plastic dowels (part #4) into rear panels (parts H & I).



- |     |   |      |
|-----|---|------|
| #1  |  | x 12 |
| #4  |  | x 15 |
| #14 |  | x 1  |
| #16 |  | x 4  |

Step 5. Screw cam bolts (part #2) into partition panel (part E) using phillips head screwdriver. Insert cam locks (part #1) and plastic dowels (part #4) into partition panel (part E) and top supports (part F).

Note: Do not overtighten cam bolts. Stop tightening once threads on cam bolt are no longer visible.

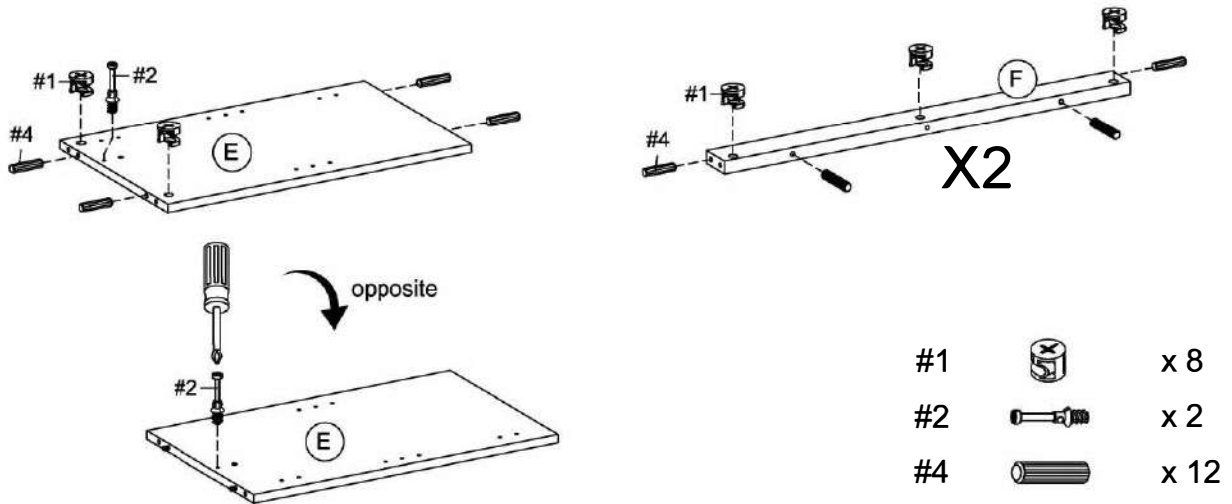

Step 6. Screw cam bolts (part #2) into pillar supports (part J), bottom left support (part M) and bottom right support (part N) using phillips head screwdriver. Insert cam locks (part #1) and plastic dowels (part #4) into bottom middle support (part L), bottom left support (part M) and bottom right support (part N).

Note: Do not overtighten cam bolts. Stop tightening once threads on cam bolt are no longer visible.

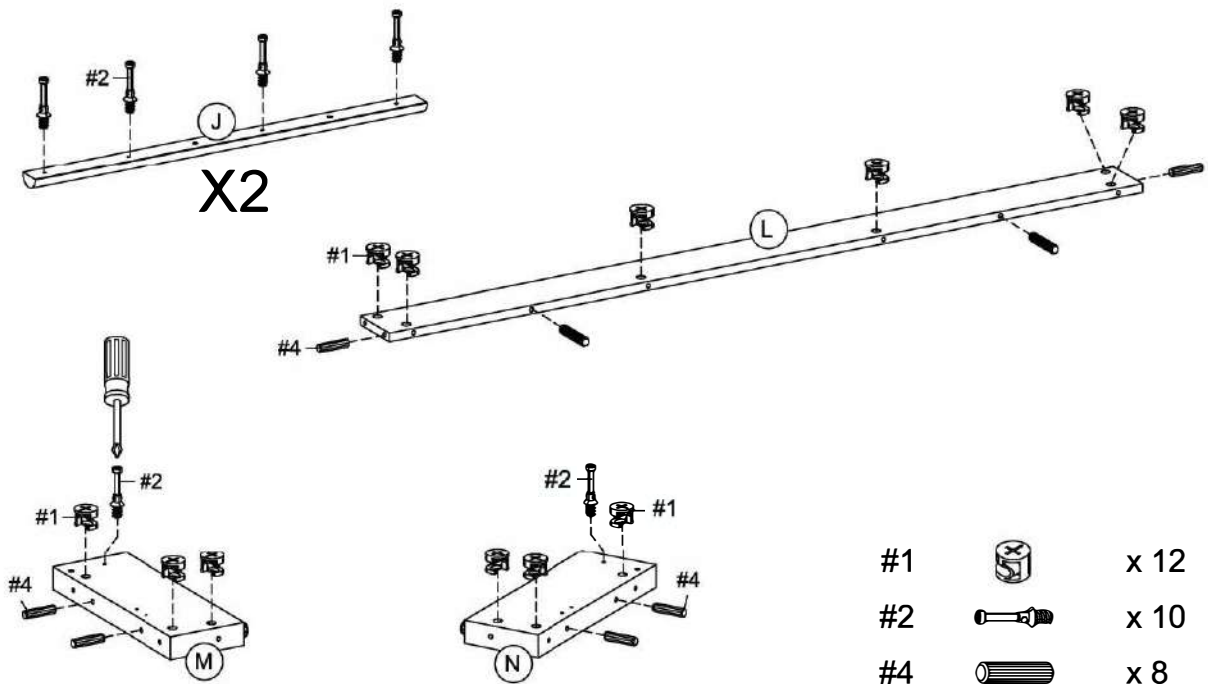

Step 7. Attach top rear panel (part H) to bottom rear panel (part I).

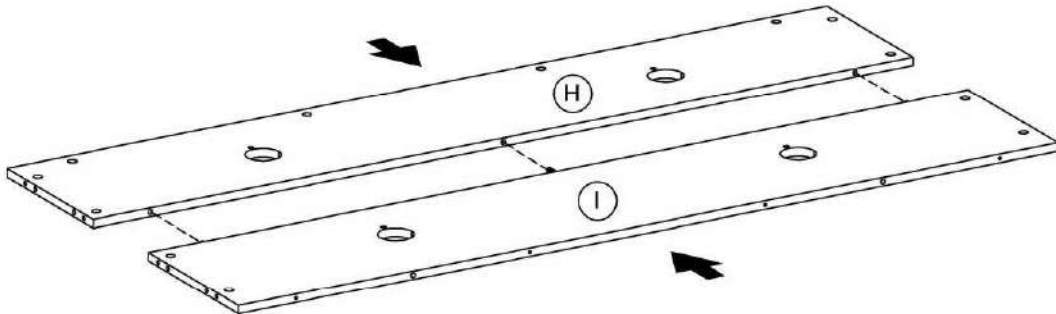

Step 8. Put partition panel (part E) on rear panels (parts H & I). Attach top support (part F) to partition panel (part E). Then attach left panel (part C) to assembled unit (parts F, H & I). Use phillips head screwdriver to turn cam locks (part #1) clockwise to fasten.

Note: Cam locks must rotate a full 180°. See pictured insert.

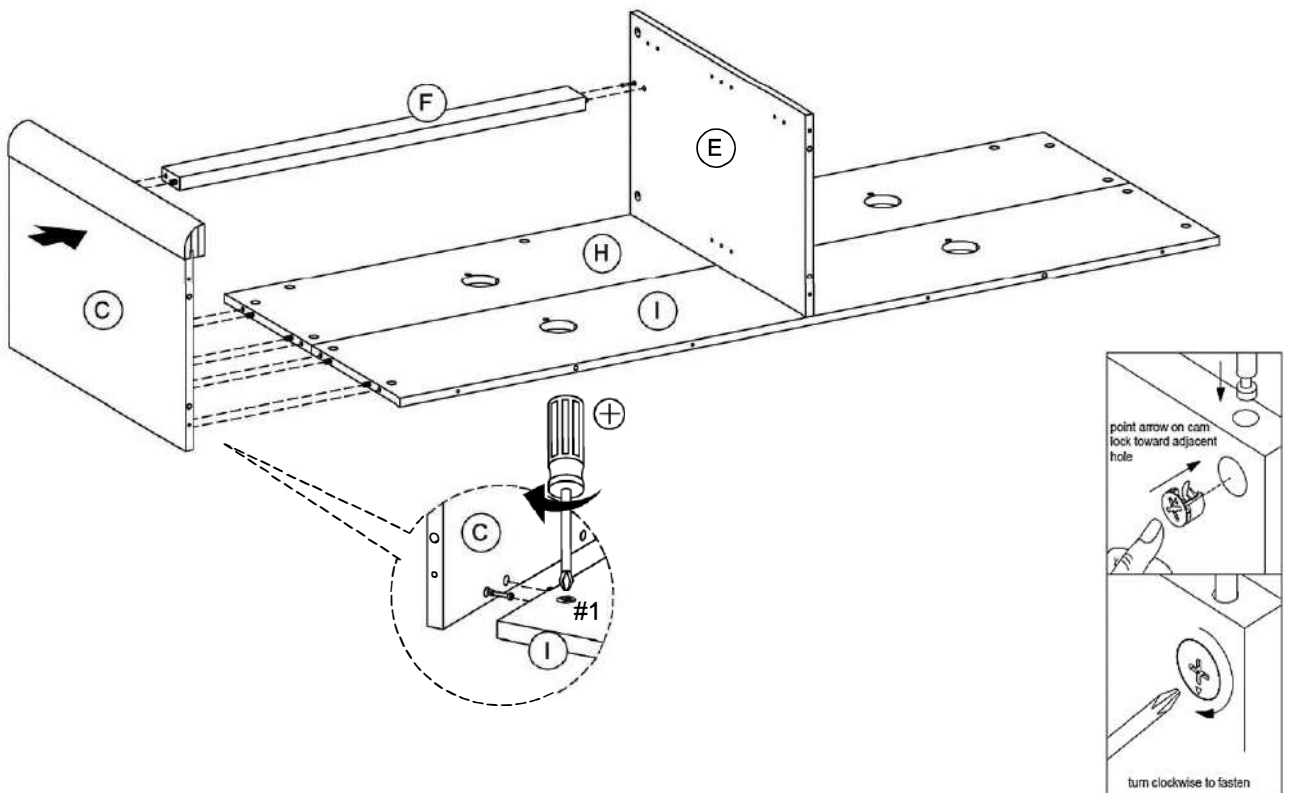

Step 9. Attach top support (part F) and right panel (part D) to assembled unit (parts E, H & I). Use phillips head screwdriver to turn cam locks (part #1) clockwise to fasten.

Note: Cam locks must rotate a full 180°. See pictured insert.

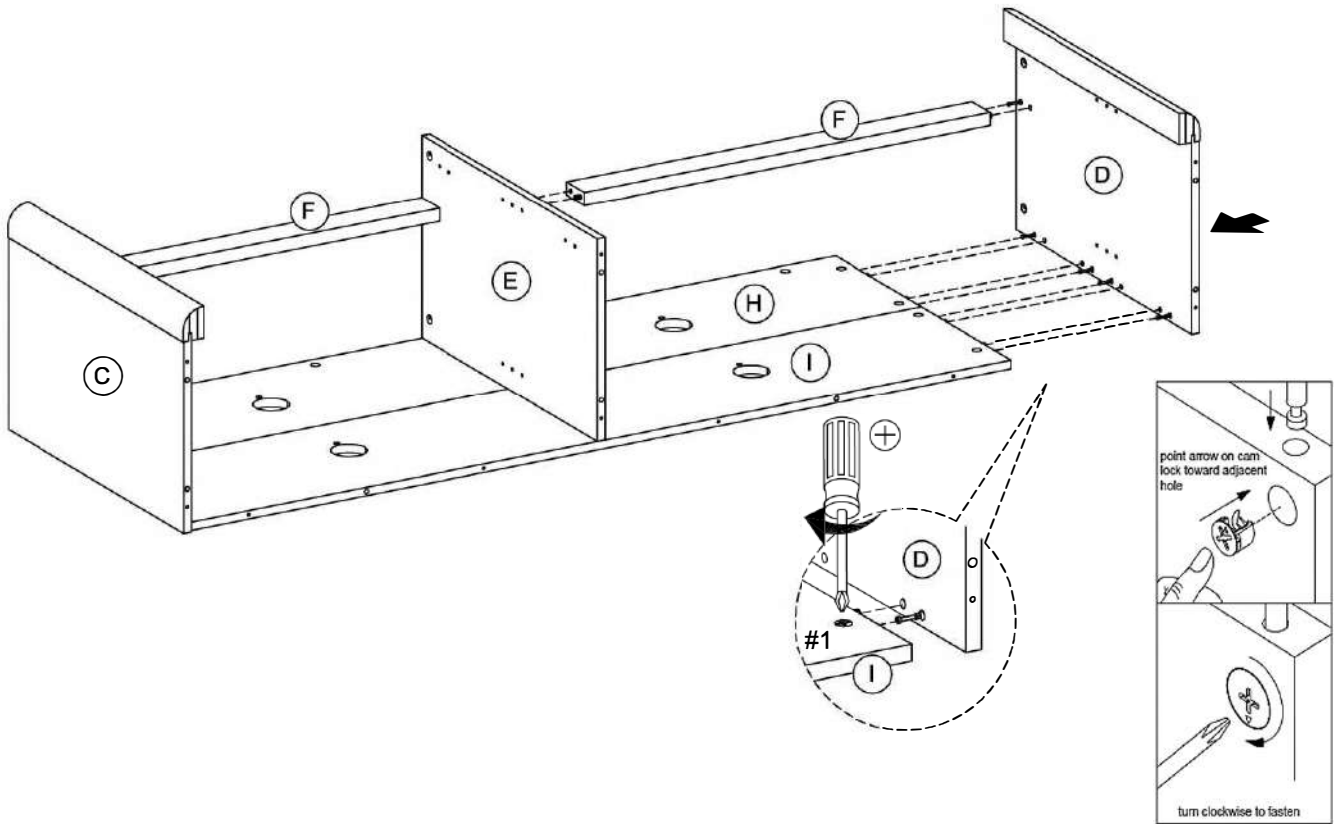

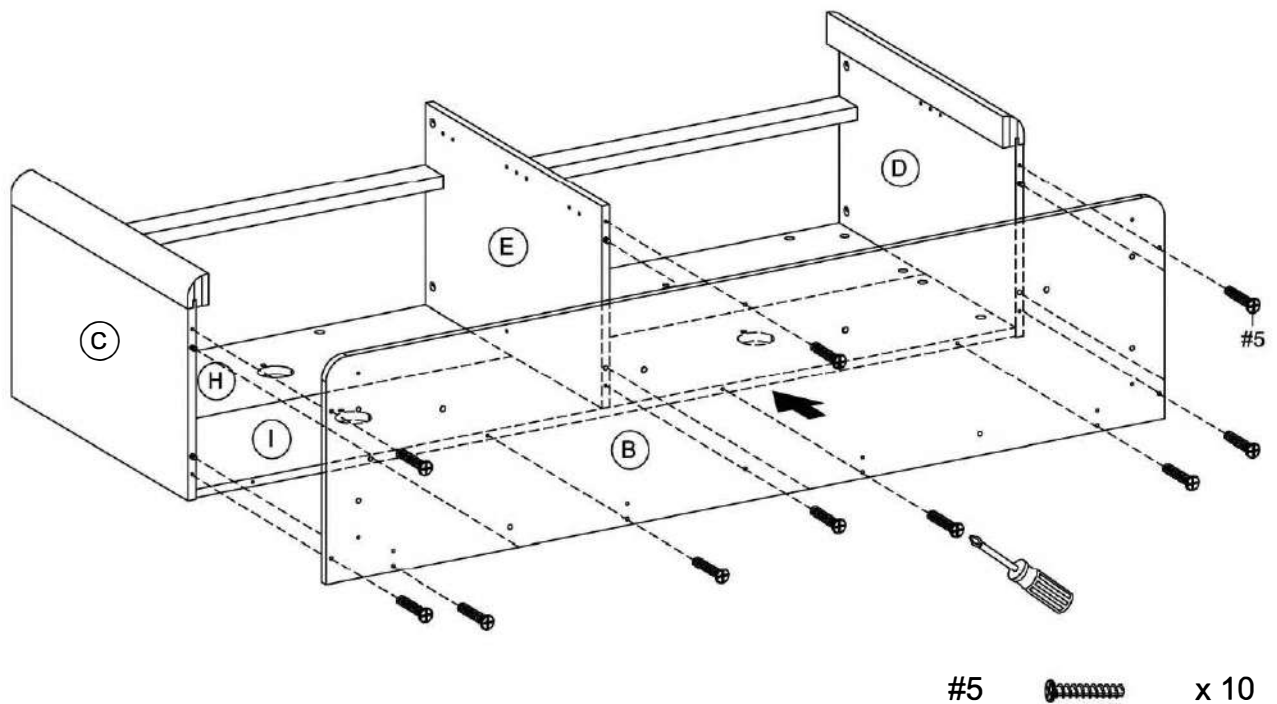

Step 10. Attach bottom panel (part B) to assembled unit (parts C, D, E & I) using confirmat screws (part #5) and phillips head screwdriver.

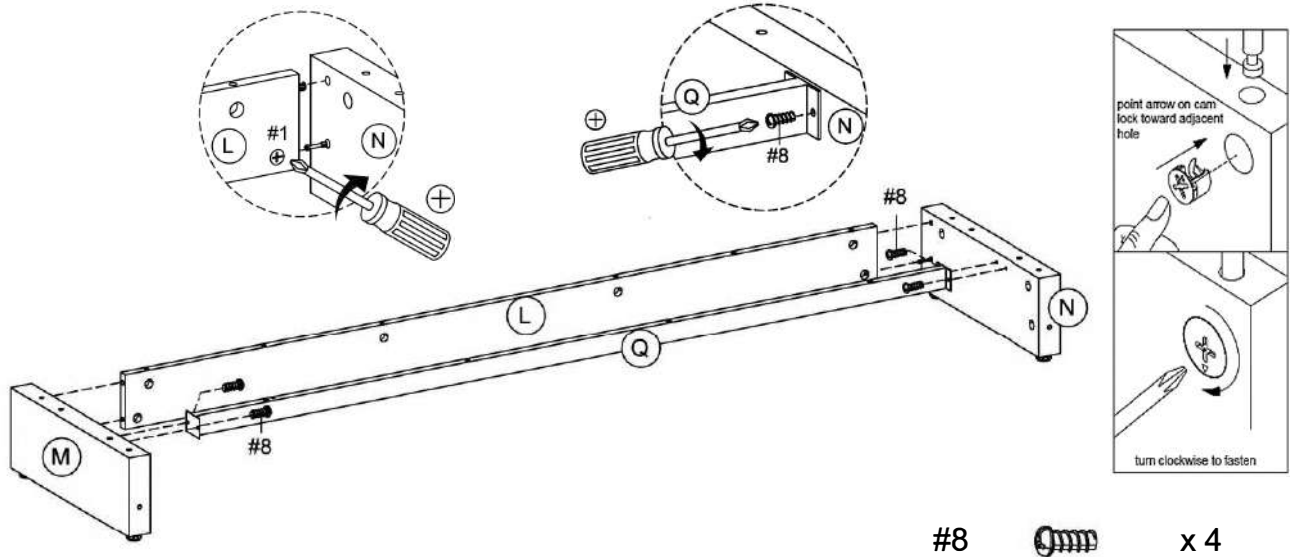

Step 11. Attach bottom left support (part M) and bottom right support (part N) to bottom middle support (part L) and metal support (part Q) using varianta screws (part #8) and phillips head screwdriver. Use phillips head screwdriver to turn cam locks (part #1) clockwise to fasten.

Note: Cam locks must rotate a full 180°. See pictured insert.



#8  x 4

Step 12. Attach assembled unit (parts L, M, N & Q) to bottom panel (part B) using bolts (part #6), spring washers (part #10), flat washers (part #15) and phillips head screwdriver. Use phillips head screwdriver to turn cam locks (part #1) clockwise to fasten.

Note: Cam locks must rotate a full 180°. See pictured insert.

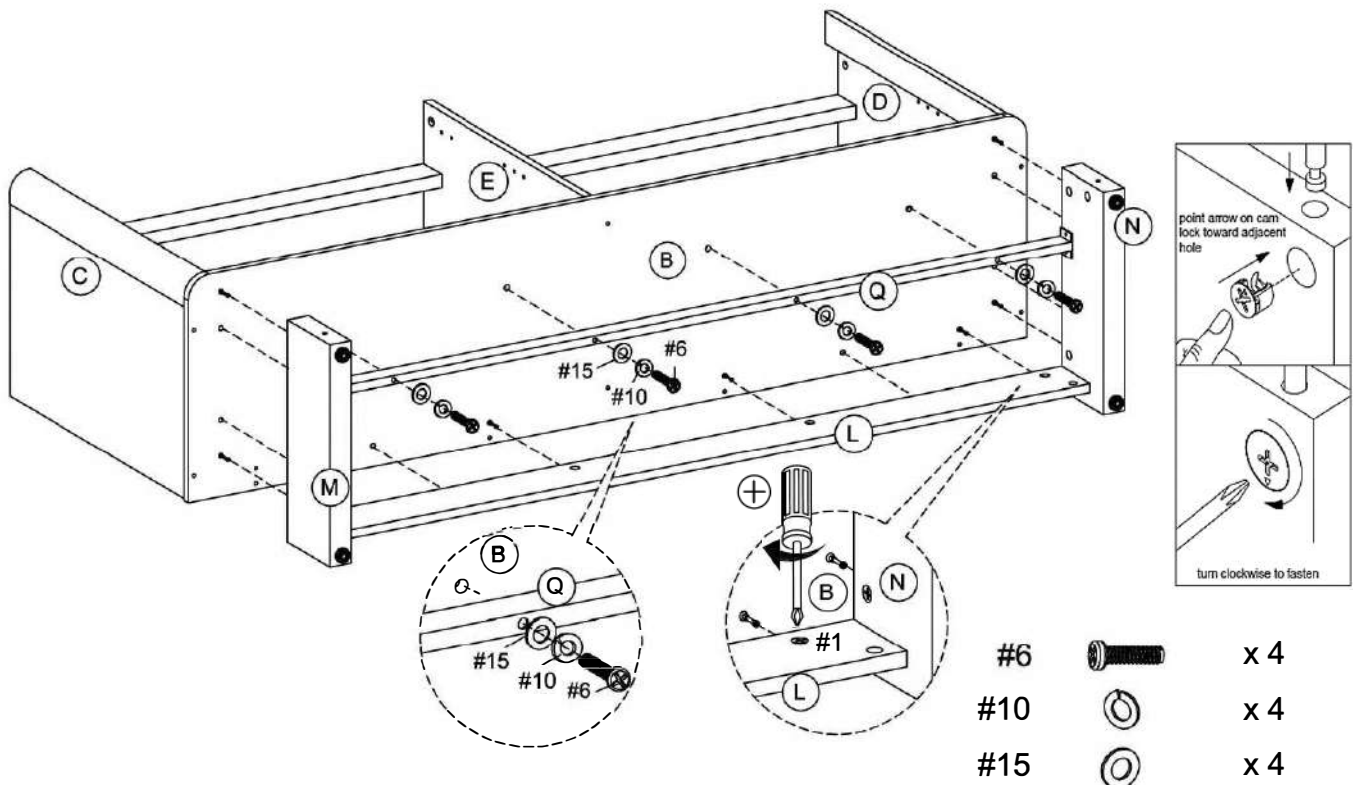

#6  x 4  
 #10  x 4  
 #15  x 4

Step 13. Attach pillars (part G) to bottom panel (part B).

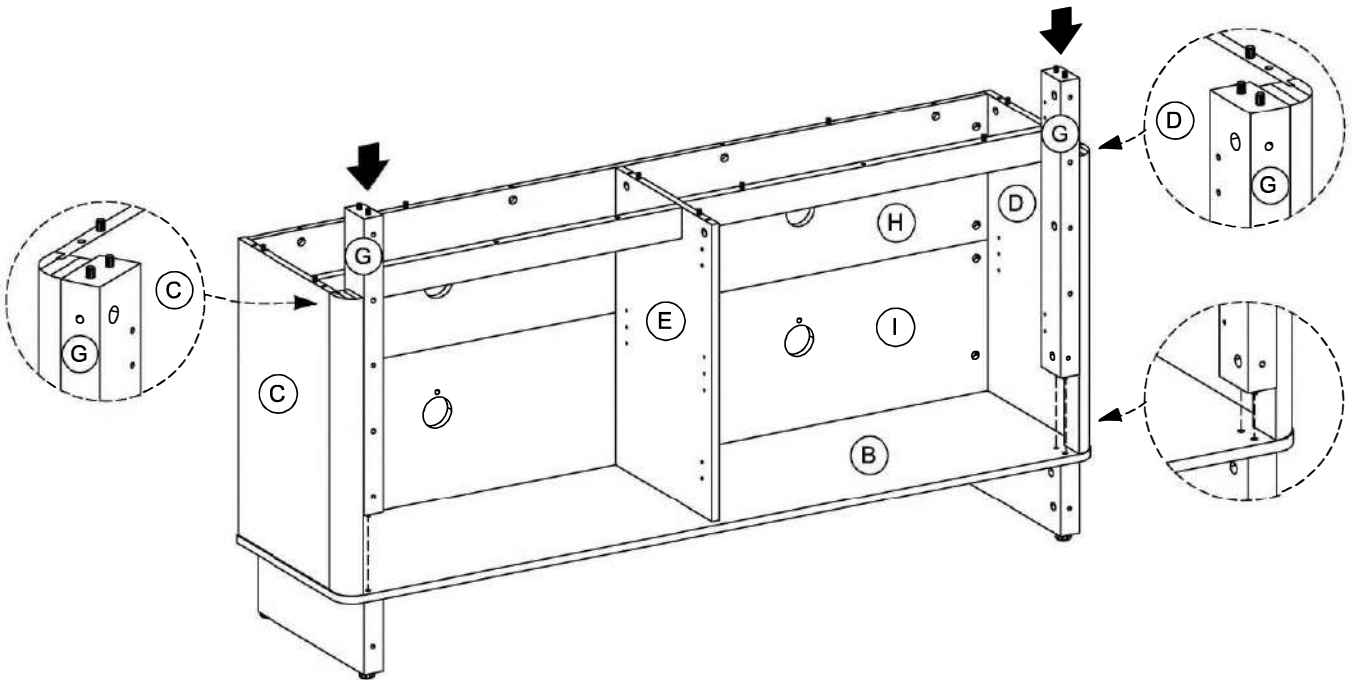

Step 14. Attach top panel (part A) to assembled unit (parts C, D, E, F, G & H).  
Use phillips head screwdriver to turn cam locks (part #1) clockwise to fasten.

Note: Cam locks must rotate a full 180°. See pictured insert.

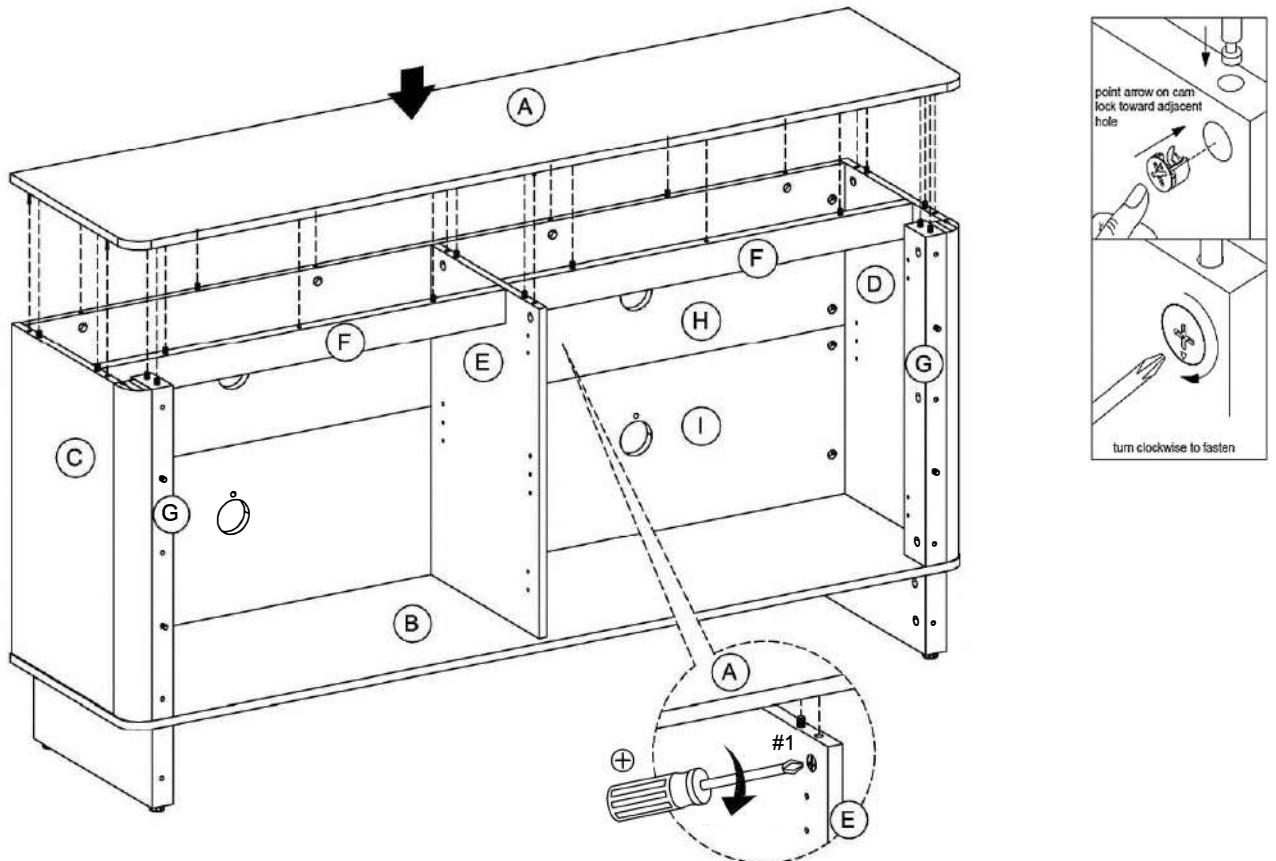

Step 15. Attach pillar supports (part J) to assembled unit (parts G, M & N).  
Use phillips head screwdriver to turn cam locks (part #1) clockwise to fasten.

Note: Cam locks must rotate a full 180°. See pictured insert.

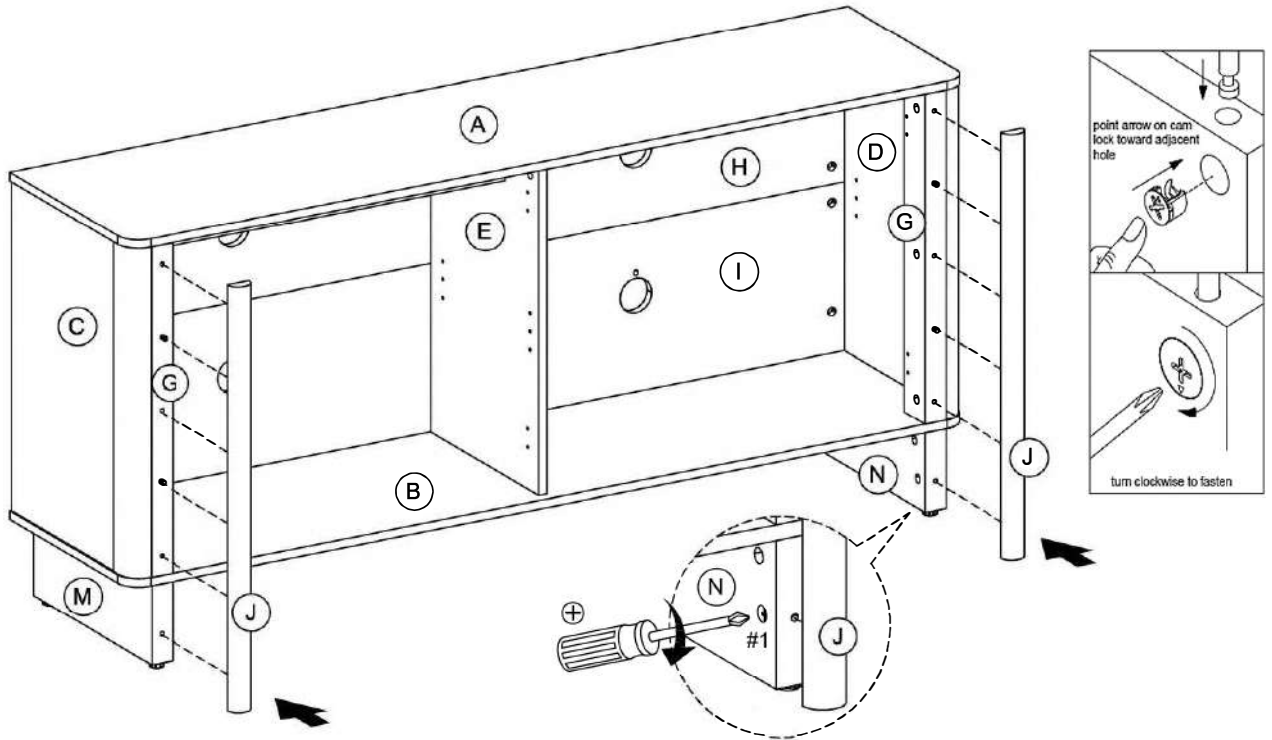

Step 16. Use cam stickers (part #3) to cover all cam locks (part #1). Place shelf pins (part #11) into desired position and slide adjustable shelves (part K) in to place.

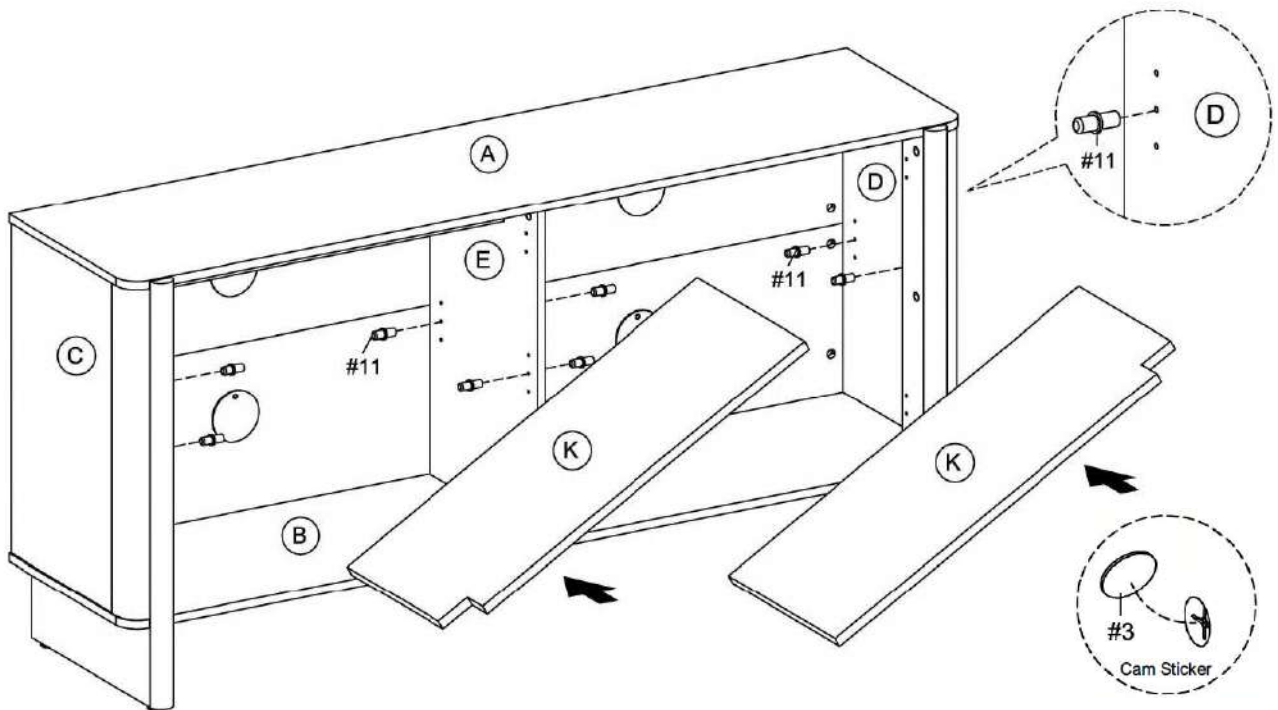

#3  x 42

#11  x 8

Step 17. Attach half curve hinges (part #13) to doors (part O) using phillips head screwdriver.

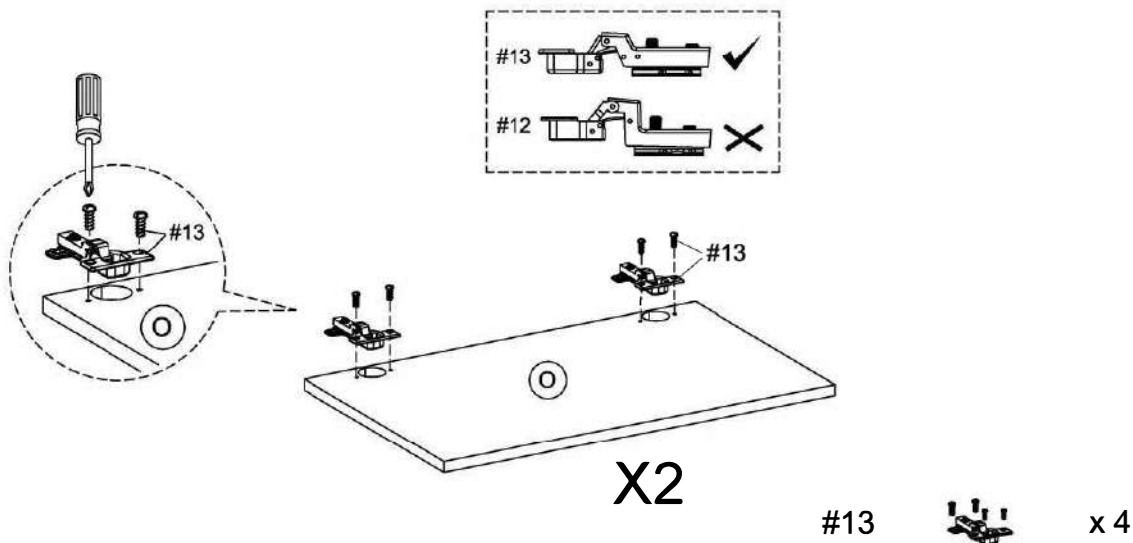

Step 18. Attach doors (part O) with half curve hinges (part #13) to partition panel (part E) using phillips head screwdriver.

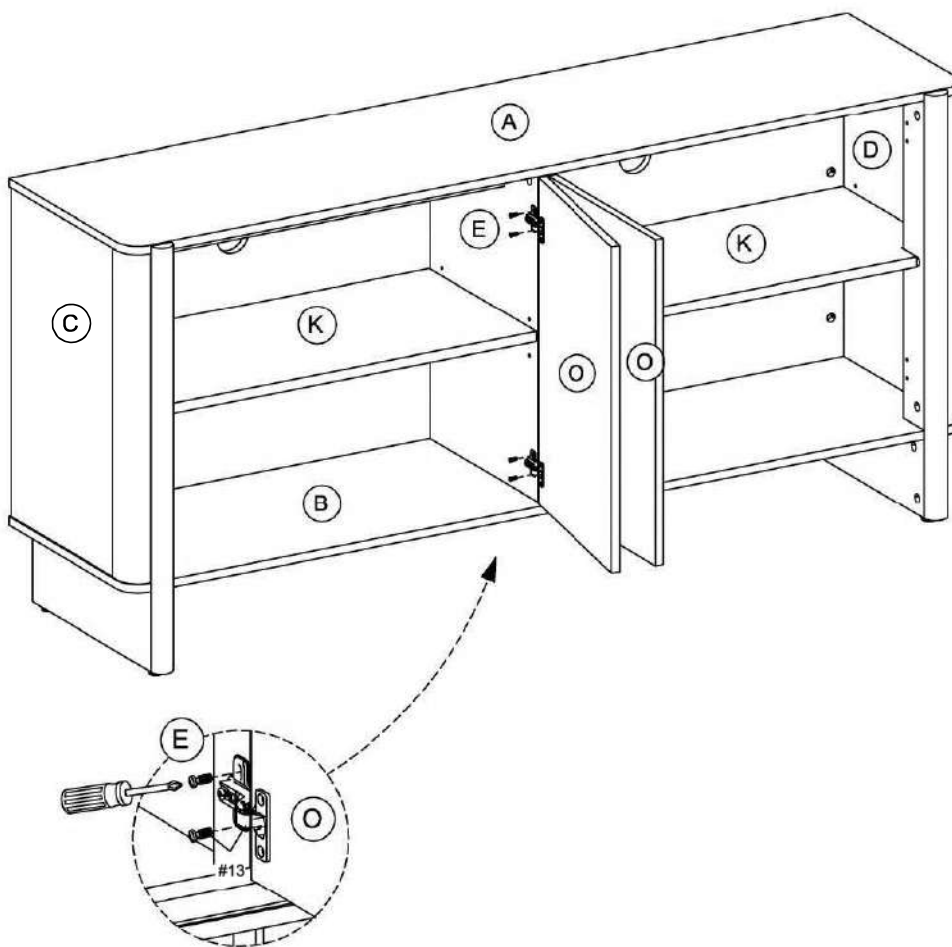

Step 19. Attach full curve hinges (part #12) to doors (part O) using phillips head screwdriver.

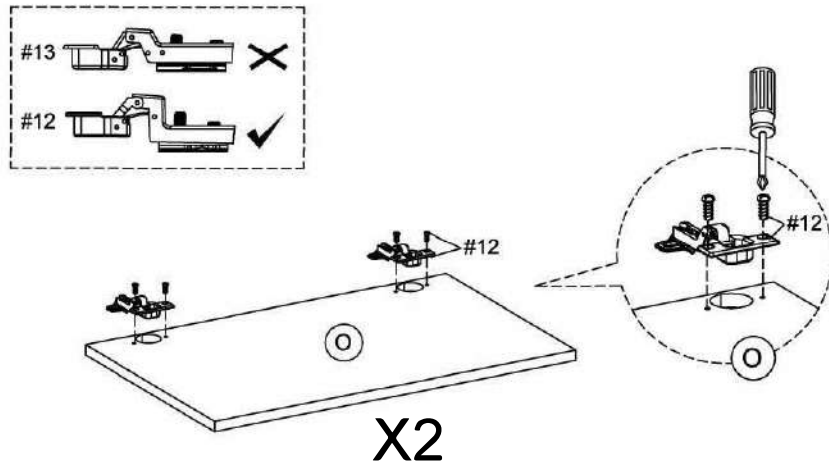

#12 x 4

Step 20. Attach doors (part O) with full curve hinges (part #12) to pillars (part G) using phillips head screwdriver.

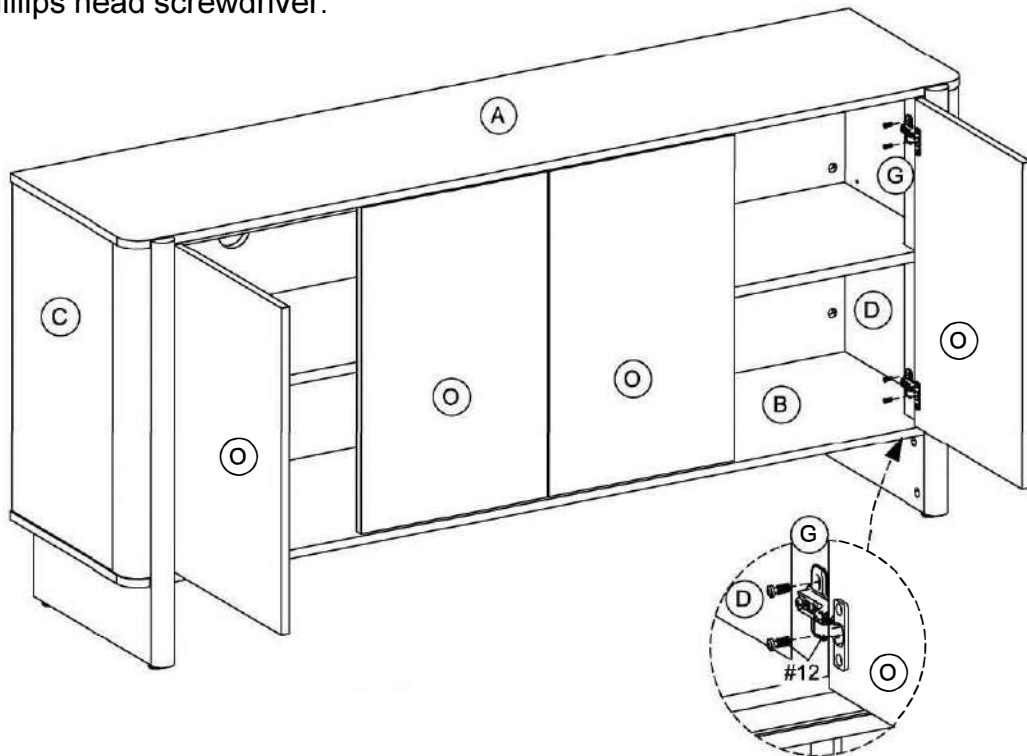





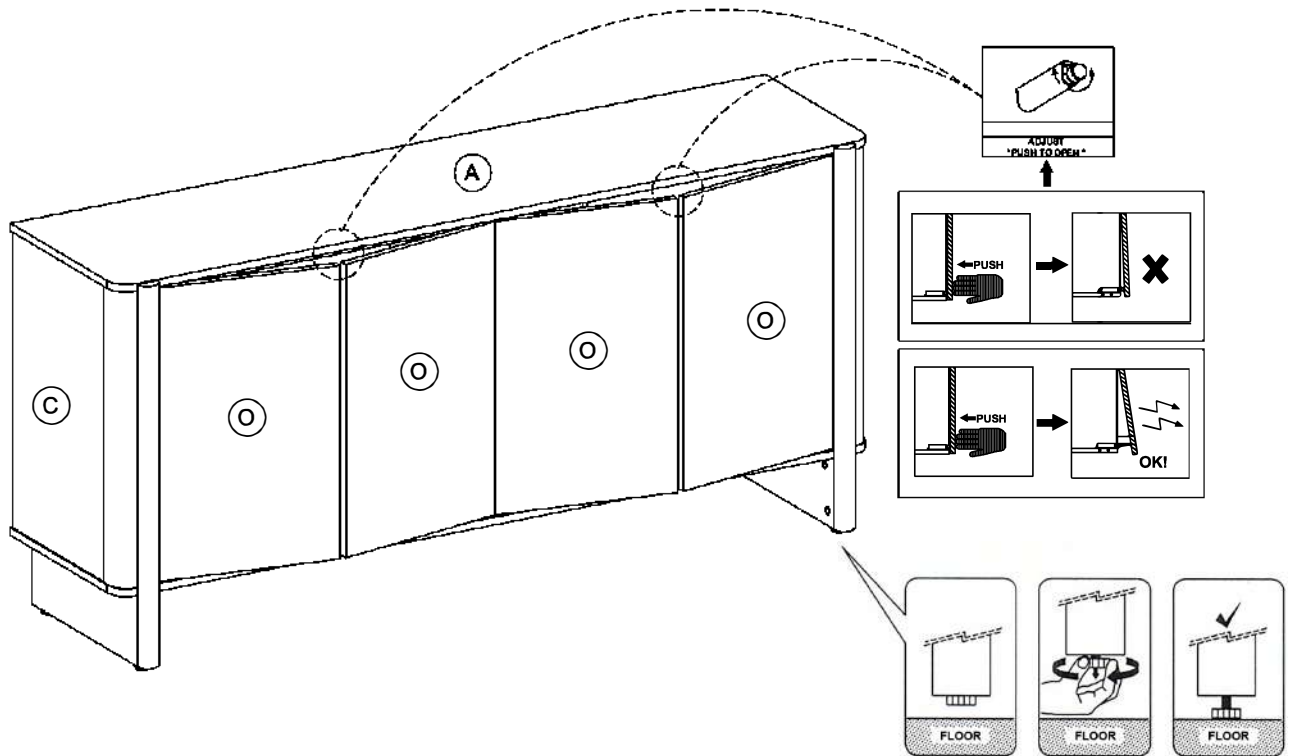

Step 21. Adjust push to open (part #9) until door can successfully open. See pictured insert.

Note: It is important to adjust levelers once fully assembled and upright.  
Extend adjustable leveler until it's firmly in contact with the floor. If relocating, adjust levelers as needed until it's firmly in contact with the floor in new location.

Important: Safety strap kit (part #17) must be installed to prevent tipping, damage and/or injury.



#17	A	B	C	D	#18
					
Safety Strap Kit 1 SET	Bracket 2 PCS	Short Screw 1 PC	Long Screw 1 PC	Safety Wall Strap 1 PC	Wall Anchor 1 PC

## SAFETY WALL STRAP INSTALLATION

**NOTE:** It is highly recommended to install this safety strap kit to prevent tipping, damage and/or injury.

1. Insert short screw (B) and safety wall strap (D) through bracket (A) and attach to top panel (part A) using phillips head screwdriver.
2. Drill 1 1/32" hole where you want to secure the unit. The drilled hole will be at the same height as hole in top panel (part A) where bracket (A) is attached. Tap wall anchor (part #18) into the hole.
3. Insert long screw (C) and safety wall strap (D) through bracket (A) into wall anchor (part #18) using phillips head screwdriver.

**Note:** This item is not intended for clothing storage use.

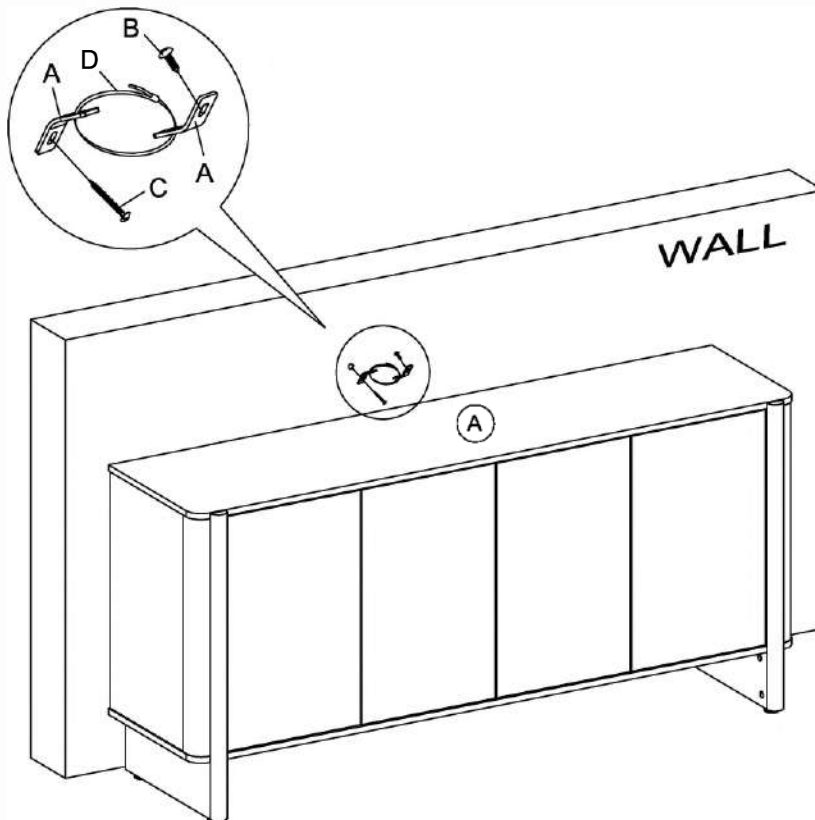

<b>▲ WARNING</b>	
	Children have died from furniture tipover. To reduce the risk of furniture tipover:
	<ul style="list-style-type: none"> <li>• ALWAYS install tipover restraint provided.</li> <li>• For use with televisions weighing 50lbs (23kg) or less. Use with heavier televisions may result in instability causing tip-over resulting in death or serious injury.</li> <li>• NEVER allow children to stand, climb or hang on drawers, doors, or shelves.</li> <li>• NEVER open more than one drawer at a time. Place heaviest items in the lowest drawers.</li> </ul>
	<i>This is a permanent label. Do not remove!</i>

**ADJUST YOUR DOORS TO MAKE THE GAPS MORE EVEN (OPTIONAL).**

**STEP 1**

Open the door

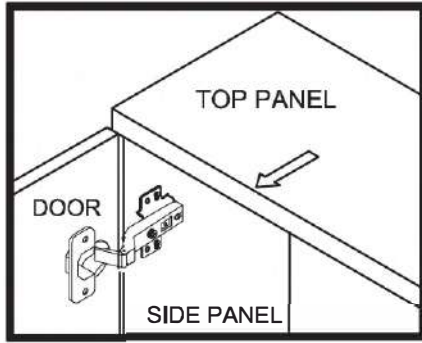

**STEP 2**

Adjust the gap between door panel and side panel

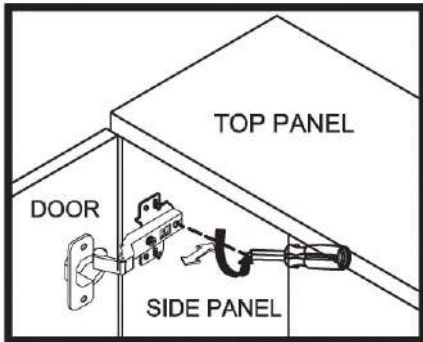

Loosen the screw indicated a little, adjust the hinge to right position (see step 2a & 2b), then tighten the screw.

**STEP 2a MOVE DOOR IN**

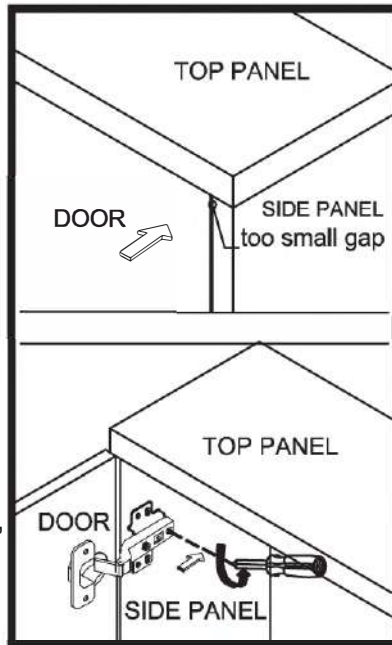

Push the hinge back a little.

**STEP 2b MOVE DOOR OUT**

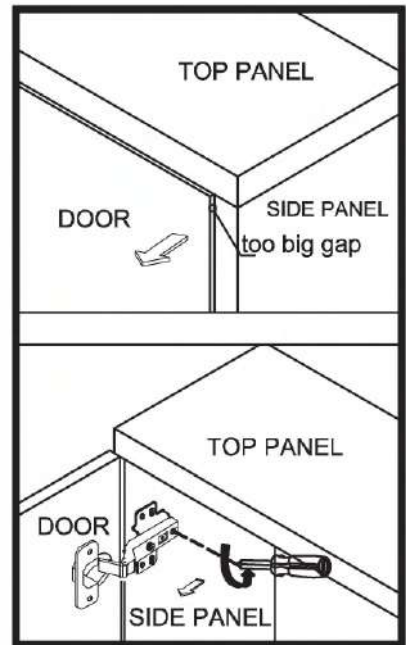

Pull the hinge forward a little.

**STEP 3**

To adjust the gap between two door

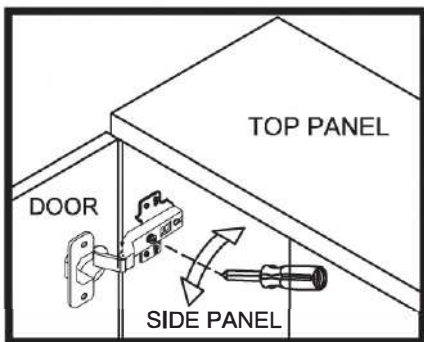

Loosen or tighten the screw indicated a little to adjust the gap between doors panels (see step 3a & step 3b)

**STEP 3a MOVE DOOR RIGHT**

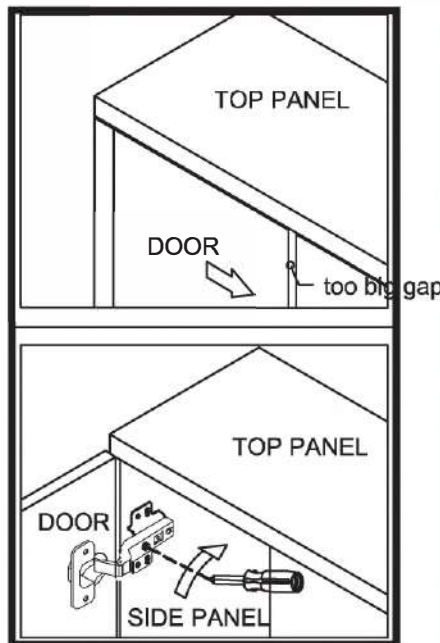

Turn the screw clockwise a little as shown to make the gap small.

**STEP 3b MOVE DOOR LEFT**

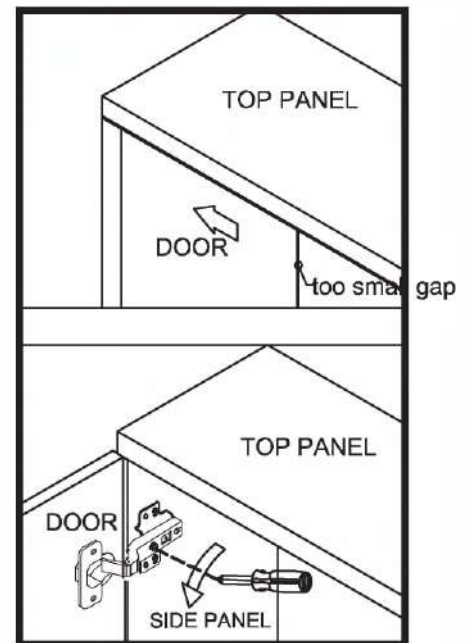

Turn the screw counterclockwise a little as shown to make the gap big.

**PO#73614**

**CF4225**

**MADE IN INDONESIA**