



**T400A**  
**T400 Turntable**  
**Instruction Manual**

---



Questions, problems, missing parts?  
Before returning to the store, call Customer Service  
8 a.m. – 6 p.m., EST, Monday – Friday  
1-888-CROSLEY  
[www.crosleyradio.com](http://www.crosleyradio.com)

## Safety Instructions

---

Read and understand this entire manual before using this product. Keep these instructions for future reference.

1. Do not use this product near water.
2. This product should be operated only by the type of power source indicated on the marking label or in this instruction manual.
3. Do not defeat the safety purpose of the polarized plug. A polarized plug has two blades with one blade wider than the other. This plug will fit into the power outlet only one way. If you are unable to insert the plug fully into the outlet try reversing the plug. If the plug should still fail to fit, contact your electrician.
4. Protect the power cord from being walked on or pinched particularly at plugs, convenience receptacles, and the point where they exit from the product.
5. Do not overload wall outlets, extension cords, or integral convenience receptacles as this can result in a risk of fire or electric shock.
6. Never push objects of any kind into this product through openings as they may touch dangerous voltage points or short-out parts that could result in a fire or electric shock. Never spill liquid of any kind on the product.
7. Do not attempt to service this product yourself as opening or removing covers may expose you to dangerous voltage or other hazards. Refer all servicing to qualified service personnel.
8. Changes or modifications to this unit not expressly approved by the party responsible for compliance could void the user's authority to operate the equipment.
9. Do not use attachments not recommended by the product manufacturer as they may cause hazards.
10. A product and cart combination should be moved with care. Quick stops, excessive force, and uneven surfaces may cause the product and cart combination to overturn.
11. Slots and openings in the cabinet are provided for ventilation and to ensure reliable operation of the product and to protect it from overheating. Do not block or cover these openings.
12. Unplug the product during lightning storm or when unused for long periods of time.

## Items in this package

---

Before throwing away any packaging materials, please check thoroughly and make sure you find the following items that come along with this package:

- Turntable
- Turntable Lid
- Turntable Platter
- Turntable Slip Mat
- 45 RPM Adapter
- Power Adaptor

Please contact Crosley Customer Service if there is any accessory missing from the package. **Retain the original packaging materials for exchange or return purposes.**

## Specifications

---

Power	AC power adaptor, DC output 12V 200mA
Power consumption	2W
Turntable speed	33 <sup>1</sup> / <sub>3</sub> , 45 RPM
Replacement needle	Crosley NP5

Note:

- *Design and specifications are subject to change without notice.*
- **To help save power consumption, some models will comply with ERP energy saving standard. When there is no audio input for 20 minutes, their powers will automatically cut-off. To turn power back on and resume playing, you will need to turn off the power and turn it on again.**

## Product Description

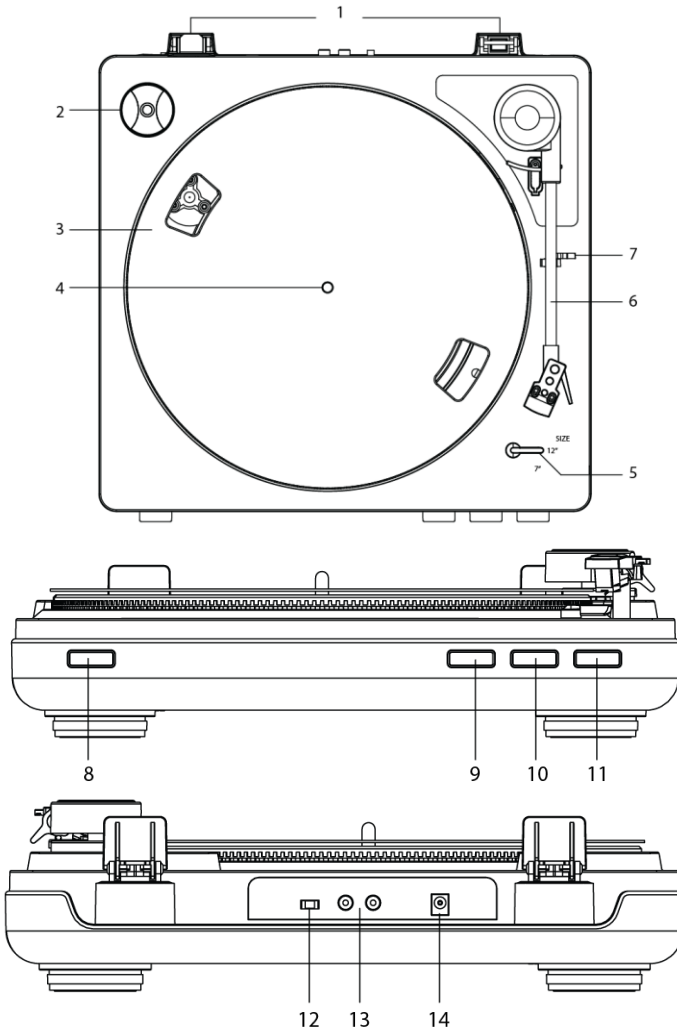

- |                             |                              |
|-----------------------------|------------------------------|
| <b>1. Hinges</b>            | <b>8. Speed Selector</b>     |
| <b>2. 45 RPM Adapter</b>    | <b>9. Start Button</b>       |
| <b>3. Turntable Platter</b> | <b>10. Stop Button</b>       |
| <b>4. Turntable Spindle</b> | <b>11. Lift Button</b>       |
| <b>5. Size Selector</b>     | <b>12. Phone Line Switch</b> |
| <b>6. Tonearm</b>           | <b>13. RCA Jack</b>          |
| <b>7. Hold Down Clip</b>    | <b>14. Power Jack</b>        |

## Initial Setup

---

### Essential Setup

1. Place the unit on a flat and level surface. The selected location should be stable and free from vibration.
2. Install the turntable lid to the hinges.
3. Remove the tie-wrap that is holding the tonearm.
4. Install the turntable platter and drive belt accordingly.
5. Place the slip mat on top of the turntable platter.
6. Connect AC adaptor to the Power Jack of the unit.

*Note: Do not plug the AC power adaptor to power outlet before all the assembly is completed. Before turning the power on, make sure again all the connection settings are correct. Always turn off the power when connecting or disconnecting.*

### Turntable Platter and Belt Setup

1. Install the drive belt over the inner ring under the platter and make sure it won't fall off during the setup.
2. Place the platter through the turntable spindle, then rotate the platter until you see the drive motor pulley through the window at the top right corner.
3. Carefully grab the drive belt and put it around the slot of motor pulley.

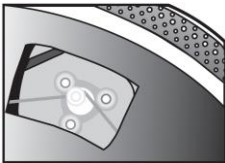

## Stereo System Connection

---

### RCA Jacks

- The RCA Jacks output analog line-level signals and could be connected directly with a pair of active/powered speakers or the appropriate input of your stereo system.
- The Red plug connects with the Right channel and the White plug connects with the Left channel.

*Note: The RCA Jacks are not designed to be connected directly to the passive/unpowered speakers. If connected to the passive speakers, the volume level will be very low.*

## **Turntable Operation**

---

### **Automatic Operation**

1. Set the Size Selector to the appropriate record size.
2. Set the Speed Button accordingly.
3. Place the record on the turntable. Use the 45 RPM Adapter if necessary.
4. Remove the stylus protector from the stylus assembly.  
*Note: To avoid stylus damage, make certain the included stylus guard is in place whenever the turntable is being moved or cleaned.*
5. Release the tonearm Hold Down Clip.  
*Note: when the turntable is not in use, remember to lock back hold down clip.*
6. Gently push the START Button. The turntable will start and the tone arm automatically will move to the record. When the record has finished playing, the tone arm will automatically return to the tone arm rest and the turntable will shut off.
7. To stop playing the record before it reaches the end, press the STOP Button. The tone arm will lift and return to the tone arm rest, and the turntable will shut off.
8. To pause the record before it has completed playing, press the Tone Arm Lift Button. Press the Lift button again to continue playing the record.
9. After playing is finished, lock the Hold Down Clip to secure the tonearm.

### **Manual Operation**

1. Set the Size Selector to the appropriate record size.
2. Set the Speed Button accordingly.
3. Place the record on the turntable. Use the 45 RPM Adapter if necessary.
4. Remove the stylus protector from the stylus assembly.  
*Note: To avoid stylus damage, make certain the included stylus guard is in place whenever the turntable is being moved or cleaned.*
5. Release the tonearm Hold Down Clip.  
*Note: when the turntable is not in use, remember to lock back hold down clip.*
6. Press the Lift Button in to raise the tone arm.
7. Gently move the tone arm where play is desired to begin.
8. Press the Lift button again to gently lower the tone arm and play the record.
9. After playing is finished, lock the Hold Down Clip to secure the tonearm.

*Caution: When the tone arm reaches the end of the record, it will lift and return to the tone arm rest automatically. When this happens, do not interfere with the tone arm's motion, or damage to the mechanism may occur.*

---

## Needle Replacement

---

### Removing Needle

1. Gently pull down the front edge of the needle.
2. Pull needle forward.
3. Pull out and remove.

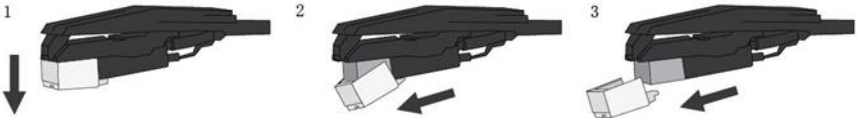

### Installing Needle

1. Position the needle with its tip facing down.
2. Line up the back of the needle with the cartridge.
3. Insert the needle with its front end at a downward angle and gently lift the front of the needle upward until it snaps into place.



---

## Turntable Maintenance

---

1. Do not touch the stylus tip with your fingers. Avoid bumping the stylus on the turntable mat or a record's edge.
2. Clean the stylus frequently with a soft brush with a back-to-front motion only.
3. Clean the records to get rid of dust or grease with a record cleaning brush and record cleaning solution.
4. Clean the turntable lid and turntable cabinet with a slightly dampened microfiber cloth.

*Note: Do not use cleanser that contains alcohol, benzene, or any other harsh chemicals which might damage the paint and finish of the turntable.*

**\*\* Crosley offers a product line of different cleaning accessories. Please ask your retailer or check out our website [www.crosleyradio.com](http://www.crosleyradio.com) for more cleaning product information.**

## Troubleshooting

---

### There is no power

- Power adaptor is not connected correctly.
- No power at the power outlet.
- To help save power consumption, some models will comply with ERP energy saving standard. When there is no audio input for 20 minutes, their powers will automatically cut-off. To turn power back on and resume playing, turn off the power and turn it on again.

### Power is on, but the platter does not turn

- Turntable mode is not selected.
- Turntable's drive belt has slipped off.

### Turntable is spinning, but there is no sound, or sound not loud enough

- Stylus protector is still on.
- Headphone are plugged in.

## FCC Statements

---

### FCC Caution:

1. This device complies with Part 15 of the FCC rules/ Industry Canada license-exempt RSS standard(s). Operation is subject to the following two conditions:
  - (1) This device may not cause harmful interference, and
  - (2) This device must accept any interference received, including interference that may cause undesired operation.
2. This device and its antenna(s) must not be co-located or operating in conjunction with any other antenna or transmitter.
3. Changes or modifications to this unit not expressly approved by the party responsible for compliance could void the user authority to operate the equipment.

### Note:

This equipment has been tested and found to comply with the limits for a Class B digital device, pursuant to Part 15 of the FCC Rules. These limits are designed to provide reasonable protection against harmful interference in a residential installation. This equipment generates, uses, and can radiate radio frequency energy and, if not installed and used in accordance with the instructions, may cause harmful interference to radio communications. However, there is no guarantee that interference will not occur in a particular installation. If this equipment does cause harmful interference to radio or television reception, which can be determined by turning the equipment off and on, the user is encouraged to try to correct the interference by one or more of the following measures:

- Reorient or relocate the receiving antenna.
- Increase the separation between the equipment and receiver.
- Connect the equipment into a circuit different from that to which the receiver is connected.
- Consult the dealer or an experienced radio TV technician for help.