

FEB 2016

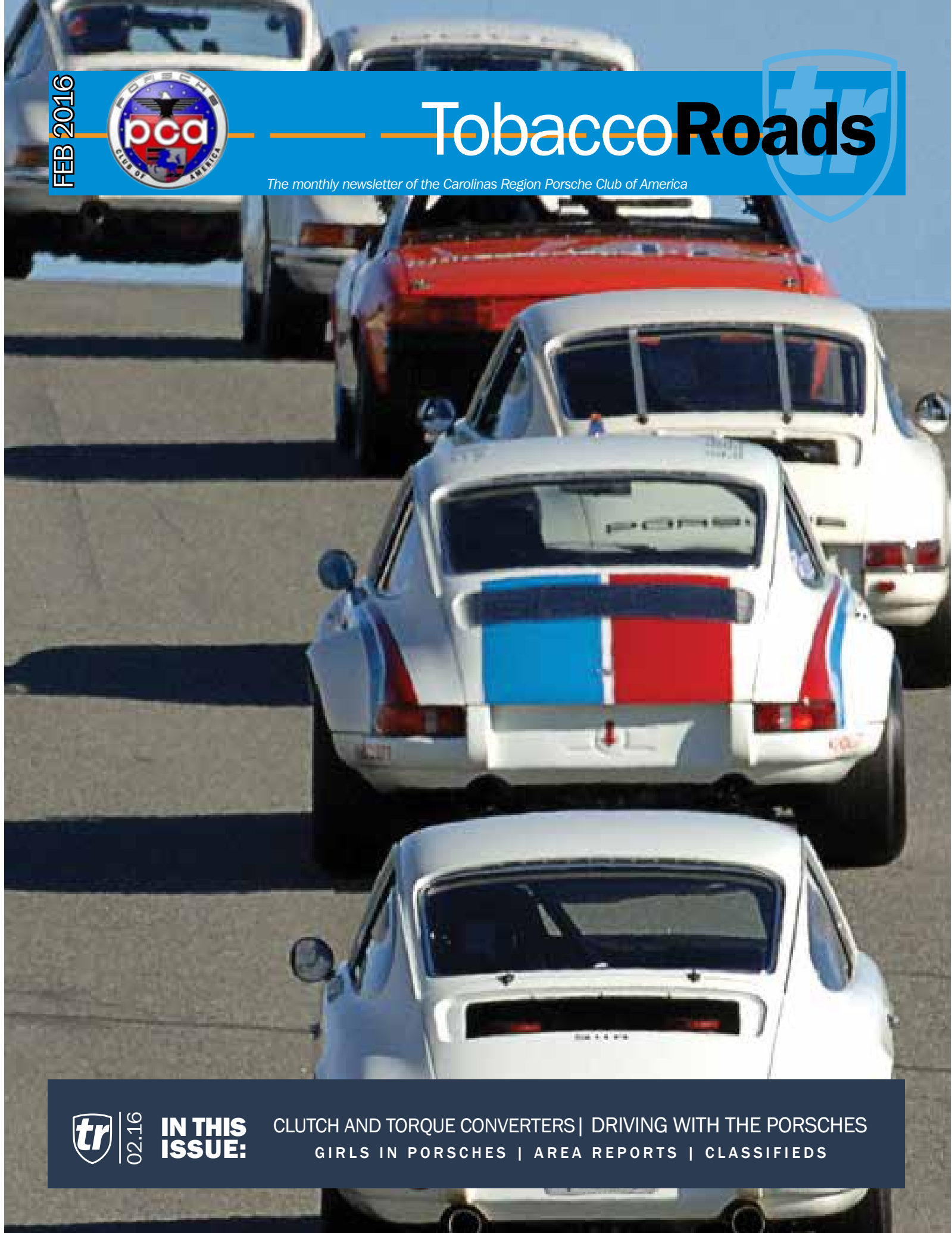

# TobaccoRoads

The monthly newsletter of the Carolinas Region Porsche Club of America



02.16

**IN THIS ISSUE:**

CLUTCH AND TORQUE CONVERTERS | DRIVING WITH THE PORSCHEs  
GIRLS IN PORSCHEs | AREA REPORTS | CLASSIFIEDS

## Porsche of Greensboro Certified Pre-Owned Inventory



2013 Porsche Boxster  
Stk# GT8744 • 15,780 miles  
**\$51,658**



2013 Porsche Cayenne S  
Stk# GT8656 • 55,723 miles  
**\$48,475**



2012 Porsche 911 Carrera  
Stk# GT8956 • 39,095 miles  
**\$57,900**



2013 Porsche Boxster  
Stk# GT8588 • 14,105 miles  
**\$37,700**



2013 Porsche 911 Carrera  
Stk# GP8560 • 19,906 miles  
**\$75,987**



2015 Porsche Cayenne E-Hybrid S  
Stk# GT8787 • 5,057 miles  
**\$76,899**

\*All prices plus tax, tag, title and \$699 dealer administration fee.

### Porsche of Greensboro

I-40 at Guilford College Road, Exit 213  
5603 Roanne Way, Greensboro, NC 27409 • 336-294-0200  
**PorscheGreensboro.com**



**PORSCHE**

## Porsche of Hickory Certified Pre-Owned Inventory



2012 Porsche 911 Carrera S  
Stk# P5617 • 16,112 miles  
**\$82,995**



2012 Porsche 911 Carrera  
Stk# P5783 • 6,017 miles  
**\$81,988**



2013 Porsche 911 Carrera  
Stk# P5692 • 38,775 miles  
**\$74,540**



2014 Porsche 911 Carrera  
Stk# 11424A • 22,540 miles  
**\$77,500**



2015 Porsche Cayman GTS  
Stk# 11447A • 4,581 miles  
**\$80,995**



2015 Porsche Panamera  
Stk# 11410 • 980 miles  
**\$74,995**



2015 Porsche 911 Targa 4S  
Stk# 11560A • 656 miles  
**\$129,995**



**PORSCHE**

### Porsche of Hickory

1205 South Center St. • Hickory, NC • 828-328-1050  
**PorscheHickory.com**

\*All prices plus tax, tag, title and \$699 dealer administration fee.



# From the Driver's Seat

Brian Powell, President



I have to admit when the 2011 Boxster Spyder came out, I was not a fan. And I will apologize off the bat to Boxster Spyder owners. I generally love the mid-engine Boxster/Cayman platform and its variations. One of the pair shows up on just about all Top 10 lists. Starting with a well-designed 987 chassis, Porsche created a great track car with the Spyder, optimizing the suspension and carving pounds wherever they could. Shedding the mechanical top, eliminating cup holders and the like, using aluminum doors and deck lids, altogether trimmed 175 pounds from an already relatively light chassis. In addition to the gains from the weight savings, they squeezed another 10 hp from the 3.4l engine. But visually, something about it just didn't fit. The styling was OK, it just didn't wow me. Maybe it was the rear deck lid that looked like an afterthought, or maybe it was the lightweight top that reminded me of a camping tent. Some would say the deck and top echo back to the original 356 Speedster top. With the top on, it limits the car to 125 mph though. So you have a track car that can't be driven fast? Yes, you can remove the top for those track days. But then you also have to add seats, harnesses and arm restraints to run most track events. They are definitely fabulous cars, just not for me.

If you've followed Parade attendance lately, you know they've become more and more popular. This year promises to be the same. The Porsche faithful will gather in Jay's Peak Vermont for the week long event held June 19th -26th. Registration will open in April. The resort offers a variety of lodging options, from traditional hotel/lodge rooms to cottage/condo options. With the challenges of hosting such a large group and the very good possibility of another sellout, PCA National has enlisted the aid of a professional service to handle lodging. If you preregistered for Parade, you will have a confirmed housing option available when you complete your Parade registration. In years past, you've completed your Parade registration on the first day, only to find out that lodging was already sold out. That was a particular problem at French Lick. Hopefully, the new process this year will avoid that. If you did not preregister, then you will still be able to select lodging from the available pool. The 2016 Parade site has posted additional information about the tours that will be available during the week. Bring your passport, as several tours travel into Canada. I'm looking forward to visiting the upper Northeast in June. When faced with a 16 hr drive to Vermont though, Angela just asked what time her flight left. Sounds like I may be looking for a caravan partner...

Until I saw the new 2016 Boxster Spyder that is... Wow. This Spyder, built off the 3<sup>rd</sup> generation Boxster/Cayman platform is spot-on. The slightly longer wheelbase of the 981, along with better styling, really sets the '16 model apart. This version of the Boxster went on a slight diet, this time only trimming 66 pounds. But instead of sharing the same engine as the rest of the line and adding lightness, Porsche upped the ante in the engine department as it did in the Cayman GT4. The Spyder will share the same 3.8l borrowed from the Carrera S and gain 45 hp over its siblings. At 375 hp, the Spyder will be the fastest Boxster ever when it arrives at dealers. Some of the pre-press reviewers have thought this version strays from the original intent of a light, nimble two-seater. In their opinion, the additional horsepower doesn't overcome the lower weight loss. I'm reserving judgment. Maybe I'll be lucky enough to make my own behind-the-wheel conclusion one day.

## ADVERTISING:

To Advertise in Tobacco Roads contact Advertising Coordinator at [advertising@carolinas-pca.com](mailto:advertising@carolinas-pca.com) or call 336.847.9293. Ads are available from Business Card size to Full Page ads.

<http://www.wesburtonperformance.com>

**Current shock service got your DAMPER DOWN?**

Authorized East coast  service center.

**IF A SHOCK CAN BE OPENED WE CAN REBUILD IT!**



**Additional services; removal, service and installation of your struts/dampers, vehicle setup and preparation.**

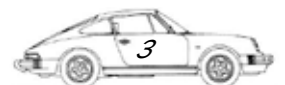

## Contents

see area reports for more detailed information

	Page
From the Drivers Seat	3
Calendar	5
New Members	7
Hysterical Ramblings	8
2016 Autocross	10
Journey is the Reward	12
Tech Werks	14
Editor's Notes	15
Area Updates	23
Classified	29

### Upstate

1st Monday of Month  
Quaker Steak and Lube,  
Greenville, SC

### Hickory

2nd Tuesday of each month @ 6:30  
Refer to monthly Area report for location/details OR contact: hickory-ad@carolinas-pca.com

### Triad

3rd Tuesday of month,  
7:00pm River Ridge Tap  
House 1480 River Ridge Road  
Clemmons, NC

### Metrolina

3rd Wednesday of Month (or  
check email updates)

### Triangle

4th Thursday of month 6:30pm  
Tobacco Road Sports Cafe  
1118 Environ Way  
Chapel Hill, NC 27517

### Sand Hills

4th Tuesday of every Month  
Rotating Meeting Location, refer to  
Area Report for details

## Recurring Cars and Coffees & Shine and Shows By Area:

### **Metrolina Area**

**3rd Sunday Monthly:** 9AM to Noon, Foxcroft  
East Shopping Center located at 7814  
Fairview Road

### **Hickory Area**

On hold until the spring. Keep your cars  
warm though

### **Triangle Area**

**3rd Saturday Monthly:** 8:30AM,  
Panera Bread Patterson Place S/C 3603  
Witherspoon Blvd Durham, NC 27707

### **Triad Area**

**Cars and Coffee:** Suspended until spring

### **Upstate**

**4th Saturday Monthly:** 8AM to 11AM, Mi-  
chelin North America Headquarters  
1 Parkway South & Pelham Road  
Next to Marriott Hotel  
Intersection of Pelham Road and The Park-  
way at Exit 54 of I-85 in Greenville, SC.



*Specializing in all models Porsche*

**IMS Solution Authorized Installer** 

We have installed dozens of IMS Retrofit bearing  
replacement kits on Boxsters, Caymans and 911s.

Peace of mind....starting at around \$2,000.

**Bring it to Exclusive Motorwerks**  
Get it done right. On Time. The first time.

- Full computer diagnosis of 1990 and newer all Porsche models
- Dedicated Engine & Transmission repair/rebuild room
- Track prep for Drivers Ed or Club Racing including precision alignments
- Trackside Support for Club Racing
- Custom fabrication work

704-483-3847 | office@exclusivemotorwerks.com  
6381 Denver Industrial Park Rd, Denver, NC 28037  
www.exclusivemotorwerks.com

Authorized Dealer for:







*Some Day 'while you wait' oil changes  
on most models*



# 2016 Calendar

See Area Reports for More Information

For additional information and events outside the Carolinas Region go to:  
<http://www.pca.org/Calendar/PCACalendar.aspx>

## February

13	Upstate Protech Chili Cook-Off
27	Triad Tech Session, Porsche of Greensboro

## March

11	DE Instructor School, CMP
12-13	Spring DE, CMP
19	10th Annual Porsche & BMW Swap Meet, Matthews, NC

## April

19-21	Sandhills tour to the Kentucky Bourbon Trail
30	Pinehurst Concours

## May

1	Autocross #1 – Lexington, NC
7	GMP Performance Open House, Charlotte, NC

## June

26	Autocross #2 – Greenville, SC
----	-------------------------------

## July

31	Autocross #3 – Lexington, NC
----	------------------------------

## August

28	Autocross #4 – Greenville, SC
----	-------------------------------

## September

24-25	Fall DE, CMP
-------	--------------

## October

2	Autocross #5 – Lexington, NC
---	------------------------------

## November

18	Solo Only DE, VIR
19-20	Season Finale DE, VIR

### Event Color Key

Light Blue	Drivers Education or Club Race
Purple	Carolinas Region Autocross Series Event
Yellow	Social, Multiple activity event, Shine & Show, Concours, etc.
Orange	Technical Session
Cyan	Driving Tour - day trip
Light Green	Driving Tour - overnight
White	No color means other notable event

**The Porsche PDK Transmission**  
 Notice the red power line moving through the transmission. Also notice the concentric White clutch pack. Porsche vastly improved the torque Converter. They have been developing this since the 959

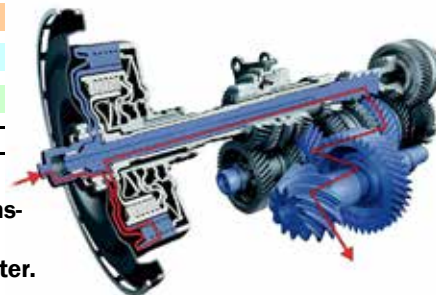

Want to see photos of recent Carolinas Region events?

Go to:  
[carolinasregionporsche-club.shutterfly.com/](http://carolinasregionporsche-club.shutterfly.com/)

If you want to contribute your own photos send an email to Ron Reed, Regional Media Coordinator, at [media@carolinas-pca.com](mailto:media@carolinas-pca.com)

INBOX

or

MAILBOX



Whether you receive the hard copy or opt for electronic only, the digital option is always available on the region's website. If you wish to opt-out of future paper delivery, simply reply to [membership@carolinas-pca.com](mailto:membership@carolinas-pca.com) with your name and area, indicating your preference to opt-out.

If you wish to continue receiving the paper copy – no action is required.



# Carolinas Region Officers and Board Members



## Executive Council



**President**  
Brian Powell  
president@carolinas-pca.com  
704.779.3631



**Vice President**  
Bill Scarbrough  
vicepresident@carolinas-pca.com



**Treasurer**  
Sadie Kilcrease  
treasurer@carolinas-pca.com  
336.847.9293



**Secretary**  
Martha Babinski  
secretary@carolinas-pca.com



**Past President**  
Doug Smith  
pastpresident@carolinas-pca.com

## Area Directors



**Hickory**  
Director  
Michael Vittorio  
hickory-ad@carolinas-pca.com  
(704) 258-3772



**Metrolina**  
Director  
Laura Varney  
metrolina-ad@carolinas-pca.com



**Sandhills**  
Marty Barrett  
sandhills-ad@carolinas-pca.com

## Standing Committee Chairs



**Membership**  
Chair  
Adam Morrison  
membership@carolinas-pca.com



**Chief Driving Instructor**  
Shane Tisdale  
chiefinstructor@carolinas-pca.com



**Events**  
Chair  
Michael Vittorio  
events@carolinas-pca.com  
(704) 258-3772



**Goodie Store**  
Chair  
Kathy Boehm  
goodiestore@carolinas-pca.com  
336-566-7501



**Club Race**  
Chair  
Bill Scarbrough  
clubrace@carolinas-pca.com  
803-600-6704



**Web Management**  
Chair  
David Violet  
web-management@carolinas-pca.com  
(828)-289-2006



**Newsletter**  
Chair  
Robert Rainer  
editor@carolinas-pca.com



**Autocross**  
Chair  
Wayne Capwell  
autocross@carolinas-pca.com



**Track**  
Chair  
John Babinski  
johnandmarthab@bellsouth.net  
864-579-1319



### Are you a Facebook member?

The Carolinas Region has a group on Facebook. Search on 'Carolinas Region - Porsche Club of America'.

## Regional Support Team



**Triad**  
Jerry Kilcrease  
triad-ad@carolinas-pca.com  
(336) 476-3120

**Currently Vacant, inquire if interested in position**

**Advertising Coordinator**  
advertising@carolinas-pca.com  
336.847.9293

**Currently Vacant, inquire if interested in position**

**Regional Historian/Archivist**  
historian@carolinas-pca.com

**Currently Vacant, inquire if interested in position**

**Communications Coordinator**  
communications@carolinas-pca.com



**Upstate SC**  
John Budinich  
upstate-ad@carolinas-pca.com  
(864) 915-0011



**Technical Advisor**  
Air-cooled 911  
John Helgesen  
John@stahlwerks.com



**Technical Advisor**  
914/914-6/916  
John Forbes  
john@blackfor-estracing.com



**Technical Advisor**  
928  
& Past President  
Chuck Zachman  
chuck@928registry.org



**Classified Ad Coordinator**  
Ed Beroset  
classifieds@carolinas-pca.com



**Photography Coordinator**  
Ron Reed  
media@carolinas-pca.com



**Triangle**  
Howard Wasserman  
triangle-ad@carolinas-pca.com  
919.538.0202



**Concours**  
Coordinator  
Mike Jones  
concours@carolinas-pca.com  
(704) 467-5042

**On the cover:**  
So this is vintage racing at RennSport Reunion. Living in the upstate, we have CulCAR, BMW and Michelin presence. You meet some interesting people who like Cars in general.  
Photo Cred... Johnny Valencia (Possibly)  
Thanks for the Upload -- John

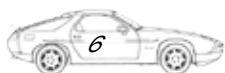

# New Members and Anniversary Memberships

The Carolinas Region would like to welcome new members and transferring members. In addition, we would like to congratulate members celebrating anniversary memberships this month for five, ten, fifteen, twenty, thirty, or more years of PCA dedication.

Welcome New Members						
Hickory	Means	Karen	Hickory	NC	2012	Cayenne
Metrolina	McNeill	Bobby	Charlotte	NC	2008	Boxster
Metrolina	Hewitt	Christian	Charlotte	NC	2016	Macan S
Metrolina	Murray	Patrick	Charlotte	NC	1983	944
Metrolina	Sack	James	Fort Mill	SC	2006	911 Carrera S
Metrolina	Luithler	Dan	Fort Mill	SC	2007	Cayman S
Metrolina	Fuhr	Matthew	Huntersville	NC	2007	911 Carrera 4S
Metrolina	Drelich	Nicole	Clover	SC		
Metrolina	Burgess	Patrick	Davidson	NC	2011	911 Carrera S
Out of Region	Gage	Greg	Julian	NC	2009	Cayman
Triad	Stewart	John	Pfafftown	NC	1983	928S
Triad	Elsner	Aaron	Winston Salem	NC	2001	911 Carrera
Triad	Harvey	Richard	Greensboro	NC		
Triangle	Beddingfield	Scott	Chapel Hill	NC	2011	911 Turbo
Triangle	Lane	Fred	Chapel Hill	NC	1984	911 Carrera
Triangle	Dodd	Leslie	Chapel Hill	NC	2014	911 Carrera
Triangle	MacDonald	Daniel	Durham	NC	2013	911 Carrera
Triangle	O'Dell	Stephen	Durham	NC		
Upstate	Gray	AJ	Greer	SC	1996	911 Carrera 4
5 Year						
Metrolina	Yeary	Sean	Belmont	NC		
Metrolina	Yeary	David	Belmont	NC	2008	Cayman
Triad	Valaoras	George	Winston Salem	NC	2009	911 Carrera
Triad	Valaoras	Georgia	Winston Salem	NC		
Triad	Clark	Darren	High Point	NC	2000	911 Carrera
Triangle	Beck	Charles	Durham	NC	2013	Boxster
Triangle	Thigpen-Beck	Betty	Durham	NC		
Upstate	Penland	Sharon	Blacksburg	SC	2008	911 Carrera S
Upstate	Penland	Robert	Blacksburg	SC		
Upstate	Schluder	Harald	Spartanburg	SC	2008	911 Carrera
10 Year						
Hickory	Seagle	J	Arden	NC		
Triad	Rutledge	John	Greensboro	NC	1997	911 Carrera
Triad	Rutledge	Andrew	Greensboro	NC		
Triangle	Trask	Tallman	Durham	NC	2011	911 Targa 4
Triangle	Trask	Julie	Durham	NC		
Upstate	Seagle	J	Fletcher	NC	1981	911 SC
15 Year						
Metrolina	Rogers	Frank	Weddington	NC	2001	911 Carrera
Sandhills	Lassiter	Larry	Troy	NC	2006	Boxster
Sandhills	Lassiter	Deloris	Troy	NC		
Triangle	Beroset	Edward	Chapel Hill	NC	1982	911 SC
Triangle	Gheezi	Marilyn	Chapel Hill	NC		
Triangle	Pappas	Arthur	Durham	NC	1989	911 Carrera
Triangle	Pappas	Adam	Durham	NC		
Upstate	Crowley	Corey	Taylors	SC	1982	911 SC

**Tobacco Roads** is the official publication of the Carolinas Region, Porsche Club of America.

**Editor**  
Robert Rainer  
728 Plume St  
Spartanburg, SC 29302  
[editor@carolinas-pca.com](mailto:editor@carolinas-pca.com)

The ideas, opinions, and suggestions expressed in *Tobacco Roads* are those of the authors and no authentication is implied by the editors or publishers. *Tobacco Roads* has not authenticated the claims and guarantees as offered in this publication.

**Keeping It Current:**

Have you bought or sold your Porsche? Moved or otherwise had a change of address or contact information? Those updates are handled at the national level of Porsche Club of America and can be updated either on the website, [www.pca.org](http://www.pca.org) or by writing to:

**PCA National Headquarters**  
**P.O. Box 6400 Columbia, MD 21045**

(410)381.0911 (p)  
(410)381.0924 (f) and email:  
[admin@pca.org](mailto:admin@pca.org)



# Hysterical Ramblings

By Howard Wasserman



## Last Month's Trivia Questions

**Q1:** Chevrolet introduced the Bel Air in 1950. For twenty points, which manufacturer was next to call a new model a Bel Air? When? Why? Porsche loves their internal designations. Every car to come from the factory has a "Typ" number associated with it. However, when a car is in the design or development stage it will often have a "code name" that designers and other employees can use to refer to it without giving things away. Such was the case with the original Targa back in 1965. Not wanting the world to know that their new open topped Porsche would be known as the Targa (derived from the famous Sicilian race "Targa Florio" – with the word "Targa" meaning "shield") the name "Bel Air" was borrowed from the posh neighborhood in Los Angeles – possibly due to the (erroneous?) assumption that it meant something like "good (belle) air". Whatever the reason, the ruse worked and Porsche stunned the automotive world with their newest innovation when the 1965 Targa was revealed. *No one answered this correctly. First time that has happened in the two years this column has been running.*

**Q2:** What did the man from Mars eat? Says who? There was a big hint to this question in last's month column. In fact it was the very last word in the column—Rapture. The rock group Blondie, led by Deborah Harry, recorded Rapture. Some of the lyrics—

And you get in your car and you drive real far  
And you drive all night and then you see a light  
And it comes right down and lands on the ground  
And out comes a man from Mars  
And you try to run but he's got a gun  
And he shoots you dead and he eats your head  
And then you're in the man from Mars  
You go out at night, eatin' cars  
You eat Cadillacs, Lincolns too  
Mercuries and Subarus



Accelerating into the front straight at Virginia International Raceway.  
Photographs by F&A Enterprises

**FROM THE STREET TO THE TRACK,  
WE'VE GOT YOU COVERED.**

623 4th Street SW #5  
Hickory, NC 29602  
Telephone: 828.322.2241  
Cell: 828.244.5169  
Web: [www.HeritageMotorwerks.net](http://www.HeritageMotorwerks.net)



The closing verse could be the first use of the phrase "hip-hop" in popular music.

'Cause the man from Mars won't eat up bars when the TV's on  
And now he's gone back up to space  
Where he won't have a hassle with the human race  
And you hip-hop, and you don't stop  
Just blast off, sure shot  
'Cause the man from Mars stopped eatin' cars and eatin' bars  
And now he only eats guitars, get up!

Perhaps most significantly, Rapture debuted in 1981, and was the first U. S. rap song to reach #1 on the Billboard 100. The music video was the first rap video ever broadcast on MTV. How did the man from Mars get into this song? Rapture was a street word for Heroin. *Correct respondents were Dixon Johnston (first, 25 points) and Charles Massler, 20 points).*

## 2015 Trivia Contest Winner



## February's Trivia Questions

**Q1:** Who "was built like a 'fridgeator with a head?"

**Q2:** What is the significance of the number 100 in Porsche history?

Each question is worth 20 points.

ALL correct answers received by the March Tobacco Roads deadline (February 15) will earn points. The FIRST correct respondent will earn an additional five points per correct answer. Let me know your guesses at [howard@hwasserman.com](mailto:howard@hwasserman.com). Don't forget—there's always at least one clue to the trivia questions somewhere in the article.

Till next time, did you know there is amateur roller derby in Raleigh? Do any of you remember the original roller derby? It was "professional" wrestling on wheels.



# GMP PERFORMANCE Track Days Approaching. Are you ready?

## Wheel & Tire Packages



## Suspension Upgrades

Free Alignment w. Coilover Install



## Safety Equipment



## Trackside Support



## Cayman DE Rental



## New Alignment Rack



\$499 Corner Balance Special

## Pickup & Delivery Service

Call for Details

## \$175 Oil Change Special

Up to 9 quarts of Mobil 1 Oil & Filter

## 704-525-4946

Mon-Fri 9am-6pm 2nd Sat 10am-2pm

©2016 Porsche Cars North America, Inc. Porsche recommends seat belt usage and observance of all traffic laws at all times.



## Our standards are as high as yours.

**\$20 Off Brake Fluid Flush - Recommended Every 2 Years**

### Porsche of Fayetteville

3211 Bragg Blvd.  
Fayetteville, NC 28303  
PorscheofFayetteville.com • 910-684-4190

\*Bring in this ad as redeemable coupon. Does not include refrigerant. Coupon not valid with any other offer. Must present coupon at time of purchase. Limit one coupon per person. Coupon does not apply to prior purchases. Other restrictions may apply. Void where prohibited.



PORSCHE

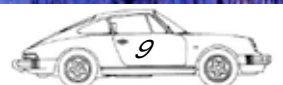

# 2016 Autocross Series

By Wayne Capwell



## 2016 Looking forward to the season

We have started a new autocross season and I want to invite everyone to try this exciting and fun event. First off let me encourage everyone to read the great article in December 2015 Panorama on autocross (page 52). It does an excellent job of highlighting some of the advantages of attending at least one of these events and dispels many of the myths and concerns for new drivers. It also has some great hints for "scoping out" the course before your first run so that it does not feel so daunting.

For those who have previously attended, please encourage someone in your area to participate. To all those who never attended an autocross, it is, in my opinion, one of the safest and most fun ways of exploring the capabilities of yourself and your car. These unique cars are designed to be driven and an autocross provides exactly the right formula to drive your car in a way you cannot legally do on the street. Not only will you enjoy the experience, you will be a better driver.

Our first event kicks off at a new facility in Lexington, NC. The old Duracell facility has been recently purchased and the new owner has had the entire parking facility resurfaced. So we will have a pristine asphalt surface at a venue not far from the Triad and Metrolina areas. However, I encourage everyone to make the trek for this event. I am sure you will have a great time, experience the fun and excitement of autocross, and enjoy the company of fellow Porsche members (and there's a free pizza lunch too).

## Porsche Driving Groups thru Germany



Travel is the only thing you buy that makes you richer.

Jessica Younginer

Virtuoso Luxury Travel Agent  
Imagine Travel

JYoung4873@aol.com

336-473-3577



Our 2016 autocross schedule is in this issue of Tobacco Roads and on our website. Registration at clubregistration.com will open in mid-March so get signed up for a great time.



We are proud to announce the return of Cody Forbes to Black Forest Racing. Over the last few years he has been working as a lead mechanic at a European performance shop in Charlotte, specializing in water-cooled Porsches. Adding his expertise to John Forbes' air cooled speciality services we are now expanding to service all years and models of Porsche vehicles.

- Porsche Factory trained master mechanic
- 40 year PCA member & supporter
- Free tech inspections for PCA members
- Ideal shop for all Porsche enthusiasts
- From street to track and everything in between

Located in Denver, NC off Old Hwy 16 at  
6480 Denver Industrial Park Rd  
(Beside the BFR red and white race trailer)

# Black Forest Racing

Tel: 704-351-3304 or 704-489-0741

Email: Office@BlackForestRacing.com

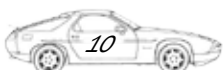



**IMS Bearing Replacement**

**\$2450**

**Prevent Serious Engine Damage**

\*Manual trans only, Tiptronic ( automatic ) extra. Not valid with any other advertised specials. Valid only at Porsche of Hickory or Greensboro. Present coupon at time of service. Plus tax, and shop supplies. Offer expires 12/31/16.

**Free General Health Inspection**

**Come in for a Complimentary  
General health inspection and receive  
10% OFF**

**any repair scheduled and repaired in 30 days of inspection**

\*Max discount of \$150. Not valid with any other advertised specials. Valid only at Porsche of Hickory or Greensboro. Present coupon at time of service. Plus tax, and shop supplies. Offer expires 12/31/16.

**Brake Fluid Service**

**\$149.95**

\*Not valid with any other advertised specials. Valid only at Porsche of Hickory or Greensboro. Present coupon at time of service. Plus tax, and shop supplies. Offer expires 12/31/16.

**Porsche of Hickory**

1205 South Center Street  
Hickory, NC  
828-328-1050

[PorscheHickory.com](http://PorscheHickory.com)



**PORSCHE**

**Porsche of Greensboro**

I-40 at Guilford College Road, Exit 213  
5603 Roanne Way, Greensboro, NC 27409  
336-294-0200

[PorscheGreensboro.com](http://PorscheGreensboro.com)

**Corrections and Amplifications**

*This is relative to information in the last Tobacco Roads. POH/POG was not identified Correctly in an Ad.*

The Folks at *Porsche of Hickory* and *Porsche Of Greensboro* Have been incredible sponsors of the Club They support our events with Cold Hard Cash.

**POH sponsors Fall Tour  
POG/POH jointly sponsor our major DE at VIR.**

We all want to express our gratitude to everyone at POH/POG

**New Advertiser  
Randall  
RaceParts**  
[www.randallraceparts.com](http://www.randallraceparts.com)

*Everything From*  
**BRAKES TO SAFETY EQUIPMENT**

**alcon** *specialist brakes & clutches*  
**Raybestos** *The best in brakes*  
**SIMPSON**  
**Sabelt**  
**BELL**  
**stillo**  
**alpinestars**  
**Arai** *HELMET*

*Contact Us Today*  
**704-658-0071**  
[www.randallraceparts.com](http://www.randallraceparts.com)



# The Journey is the Reward:

Best Drive of 2015 PART I | Riding with the Porsches

By Jim Johnson



Every year my wife and I try to go to South Carolina to visit one of my sisters, hang out by a beautiful lake, and do nothing for a week. This year was no different... until it was. This year my sister had a calendar conflict that would have her in North Carolina on the weekend we wanted to travel. We were trying to reschedule when my brother-in-law piped up and said we should bring my wife's new Golf R and meet them in North Carolina; we'd have dinner and my wife and I could follow them back to South Carolina. Sure we could do that. Why were they going to North Carolina? My brother-in-law is a new member of the South Carolina chapter of the Porsche Club of America, and his club was going to be on a weekend drive. Suddenly I couldn't get my bags packed fast enough.

to how the R felt under load, turning, accelerating, and how it responded to increased gradient. It was smooth; very smooth. The computer, and turbo removed all drama from the climb and allowed me to focus and enjoy the drive.

As we pulled into the Best Western Mountain Lodge we were greeted by the lovely sight of a parking lot full of Porsches. There are worse ways to end a long day of driving than walking around looking at a collection of Porsches, but I'm not certain there is a better one. That evening's dinner was a relaxed affair where everyone sat around talking about cars, and about good drives they

The ride down to Banner Elk, NC was your typical vacation commute of responsible driving on typical American interstate highways. The Golf R was just finishing up its official break-in period so we didn't want to beat on it; just yet. The R, while defining Hot Hatch, is the perfect vacation cruiser for two. Heated seats for the morning, a back seat for you quick access items like a soft sided cooler, and some snacks; and as much stuff as my wife wanted to take on vacation all fit in the hatch without folding down the seat.

had. The realization that they were going to allow us to follow them through the mountains the next morning; even though we didn't have a Porsche, was like being told on Christmas Eve that you'd be getting that shiny new bike, but you couldn't drive it until the next day. I wasn't certain I'd be able to sleep.

I was up early and I drove the R alone to the gas station to fill the tank. I didn't want our car to be "That Guy" who ran out of fuel and needed to stop. While I was getting excited for the day, my wife was getting anxious. Maybe she was worried about being able to keep up with the pack, or maybe I'm a better driver than I am a passenger, but when I returned to the room she was having second thoughts about driving and told me I should. Despite trying to reassure her she'd be able to keep up, she said I should do it and handed me the key.

The comfort setting on the DCC is not quite soft enough to eclipse the deteriorating seams in the road surface that have reached speed bump status, but it is much better than the kidney shattering race mode setting. In any of the three settings all the power you could ever need is at your right foot's disposal just awaiting your command. Short uphill grade on ramp from a rest area in the mountains of Kentucky? No problem. Drop the hammer and you're passing people before you have to merge. Ease off the throttle and you are back in a comfortable anonymous hatchback disguise.



Jen never hoons, so I could understand some of her reluctance. It was a brand new car; she had never pushed it, or any car, to; or even near its limit. This wasn't going to be a track day, but it was all the unknowns that were stacking up on her. I accepted the key and tried to suppress a boyish smile all the while internally I was all whoohoo! I was also vowing to get my beautiful wife to a driving school like Miles Ahead, or even a proper track day at Mid-Ohio; so if an opportunity like this came again she could show the boys what she's made of.

While past long drives have usually left me irritable, cramped, and exhausted by the time we exited the interstate near Johnson City, NC, I was feeling fresh and ready for the twisty stuff up the mountain into Banner Elk. From planning the route, I knew Banner Elk was about 3,000 feet higher than Indianapolis and I was really paying attention

The Sun was officially up, and the real mountain dew was starting to evaporate. I was trying to get my brain into driver mode and contemplating things like grip variations due to temperature differential between tarmac in sunlight or shadow, but the parking lot was full of Porsches vying

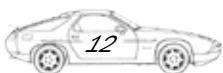



for my attention. I walked through the parking lot turned paddock as one of

the owners I met the night before was washing his colorful custom painted 944. An older gentleman a few cars away was getting a jump start on his 996, and further up the lot another is adding oil to his classic yellow Carrera. Meanwhile; my brother-in-law's pristine new racing yellow Cayman waits at the ready cued in front of the hotel with a couple of GT3's



As with all group events there was plenty of milling about and I was becoming a bit impatient for the drive to start. Thankfully we soon gathered for scheduled pre-drive discussion where the circuitous route was briefly and vaguely mentioned. There was no map, no GPS coordinates for the navigation system; it was going to be a simple follow the leader, until the leader stopped. Someone snickered that we should just follow the smoke and burnt oil smell from the aging Carrera if we got separated and everyone moved off to their rides. Not much of a briefing, but I'm sure my wife was even happier she'd given me

the key.

The long line of German engineering headed toward the center of the ski village that is Banner Elk when the last three cars, of which we were one, immediately got separated from the lead group and had to play catch up. With no directional instructions and only tail lights to follow I tapped the mode button on the center console and selected Race mode on the display and for only the second time switched the automatic transmission over to DSG flappy paddle mode. In normal traffic

Race mode and automatic setting is a bit too much. While the car sounds better it holds the revs too long before up-shifting and down shifts can feel abrupt. Interestingly the abrupt down shifts, during braking to a normal stop, can give a lunging feeling during deceleration; a feeling that is probably worse on the passenger. Also; if in regular traffic you use the DSG paddles you always feel the need to shift. I usually drive a 5 speed which feels natural to me, but at first the flappy paddle seems

distracting as I was trying to feel for shift points. The day before when I drove up the mountain in automatic it felt like the computer was being a bit to conservative for my taste. On this day, here in the mountains, all of that was gone. Playing catch-up the Golf R came alive. In Race mode using the DSG I could hold the revs to the redline before shifting, or utilize the engine to enhance braking now made smooth by the more aggressive tack, much like a manual.

Within five or so my group caught up with the rest of the cars just as they were pulling off for a fuel stop. I wasn't "That Guy," but the group leader was. I was glad for being caught up and a quick break as being quite unfamiliar with the route and the car were stressful enough without being way behind. Once all those that needed fuel were ready; the lead Carrera took off and we were at it again.



# Tech Werks – Transmissions



## Clutches and Torque Convertors

By Robert Rainer

All that power made by your engine has to go somewhere, and you want it to go to a process where the tires maintain their friction and move your car. A key component to accomplishing this relies on your transmission doing its job. Traditionally transmissions have been either manual where the driver selects when to shift, or automatic where the transmission had built in shift point. An engine actually has a limited band of horsepower and torque where it is most effective. In this series, we will learn about how our transmissions work and we will begin with a discussion on how the engine can transfer its horsepower and make torque to turn the wheels.

Mechanical car clutches are devices for engaging and disengaging two moving parts of a shaft. The two moving parts in this case are the engine crankshaft and the transmission input shaft. A clutch assembly consists of many small parts, but there are five major components:

1. The clutch flywheel  
The clutch flywheel is connected directly to the engine crankshaft and, therefore, spins with the engine's motions.

2. The clutch pressure plate  
Bolted to the clutch flywheel is the second major component: the clutch pressure plate. The spring-loaded pressure plate has two jobs: to hold the clutch assembly together and to release tension that allows the assembly to rotate freely.

3. The clutch disc  
Between the flywheel and the pressure plate is the clutch disc. The clutch disc has friction surfaces similar to a brake pad on both sides that make or break contact with the metal flywheel and pressure plate surfaces, allowing for smooth engagement and disengagement.

4. and 5. The throw-out clutch bearing and release system  
These components work together simultaneously and are key to the engaging and disengaging process. They are the release, or throw-out bearing, and the release system itself.

The clutch release bearing is connected to one end of the hydraulic (or clutch fork mechanism) and rides on the diaphragm spring of

the clutch. Depending on the type of release system, the throw-out bearing either pulls or pushes on the pressure plate diaphragm spring to engage or disengage

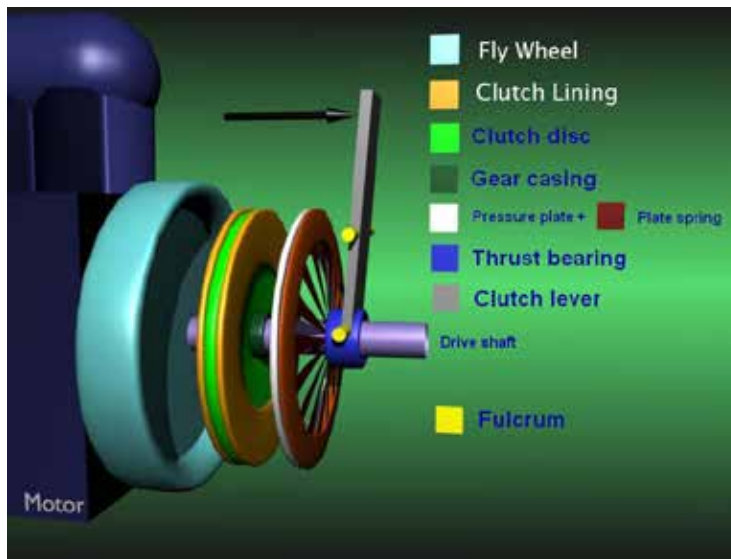

the pressure plate's grip on the clutch disc when the clutch pedal is depressed and released.

While the clutch is engaged, everything spins as one unit. When you press the clutch pedal in, the clutch assembly is disengaged. The shaft and clutch disc spin independently of the flywheel and pressure plate.

As you let the clutch pedal out, the friction surfaces on both sides of the clutch disc begin to make contact with the metal surfaces of the flywheel and pressure plate, and the power of the engine is transferred through the transmission input shaft, through the gears and right down onto the road.

The tricky part is matching up the speed of the engine to the engagement of the friction surfaces so you don't get caught in the clutches of a potentially embarrassing engine stall.

An automatic transmission on the other hand uses something called a torque converter to allow the car to idle. The main components of a torque converter are: the impeller, the turbine, the stator, and the lock-up clutch. The impeller is part of the torque converter housing, which is connected to the engine. It drives the turbine via viscous forces. The turbine is connected to the transmission input shaft. In essence, the engine turns the impeller which imparts forces on a fluid, which then rotates the turbine, sending torque to the transmission.

The transmission fluid flows in a loop between the impeller to the turbine. The fluid coupling suffers from severe churning losses (and consequent heat buildup) as the fluid returning from the turbine has a component of its velocity that



opposes the rotation of the impeller. That is, the fluid returning from the turbine works against the impeller's rotation and thus against the engine. This allows the engine to idle and the transmission to

absorb the rotation of the engine.

The stator sits between the impeller and turbine. Its goal is to minimize churning losses and to increase torque output by redirecting the fluid as it returns from the turbine to the impeller. The stator directs the fluid so that the majority of its velocity is in the direction of the impeller, helping the impeller move, and thus adding

to the torque produced by the motor. This ability to multiply torque is why we call them torque converters, not fluid couplings.

The stator sits on a one-way clutch. It can rotate in one direction only when the turbine and impeller are moving at approximately the same speed (like during highway driving). The stator either rotates with the impeller or not at all. Stators don't always multiply torque, though. They provide you with more torque when you're either at stall (applying the brakes at a stop light, for example) or while accelerating, but not during highway cruising.

In addition to the one-way clutch in the stator, some torque converters contain a lock-up clutch whose job it is to lock the turbine with the torque converter housing so that the turbine and impeller are mechanically connected. Eliminating the fluid coupling and replacing it with a mechanical connection ensures that all of the engine's torque is transmitted to the transmission input shaft.

Next month we will discuss what happens behind the engine transmission coupling and look at how gears are used to convert the engine rpms to tire rotation.

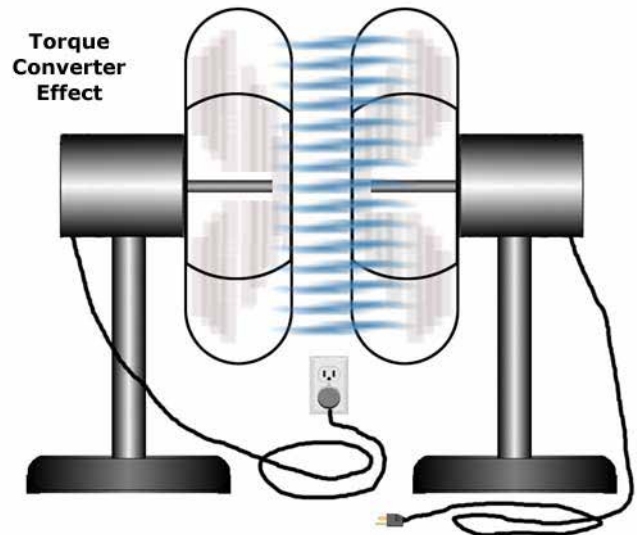

To understand how a torque converter works, think of how the one powered fan in this graphic turns the un-powdered fan using air a fluid medium. The blades on the fan will capture the wind generated by the turning fan and begin to transfer the force.

## Editor's Notes

Robert Rainer, Editor

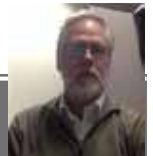

First of all, thank you for the kind words. I have been getting great feedback from the Area Directors. I hope you are enjoying Tobacco Roads. This month we are experimenting. Color cover and Color Center. I put some things outside the lines. I am still learning the program to produce this publication. Being my first attempt at a magazine, I am learning a great deal. Believe it or not, I do get quite a bit of help behind the Scenes. I truly want to thank the folks who helped proof this month's edition. I have grown with the power of folks having your back and pushing you to do better. So if you see them, thank them for what they help to make possible. My copy editors and proofreaders are Howard Wasserman, Catherine Bonfiglio and Sadie Kilcrease. Again thank you for your help and time. I also want to thank all of the area directors and regional chairs and officers. I can tell you that they do quite a bit behind the scenes, and they are wonderfully punctual and succinct. I really am grateful for you all making the deadline.

So I was given a budget at the board meeting, and I was asked to come up with a formula that we can afford. The members of the board want to add color, and the layout of this issue is what I believe will make the best use of our budgeted dollars. I ran fewer pages as well this month. We also have the option to do inside color ads, so if you begin to see that, remember those folks are supporting our efforts.

I have been enjoying learning at your expense, and I want to say thanks for the opportunity to do this publication. Also as always, send me your stories, photos, drives, technical know how and anything else you may want to share.

[Editor@Carolinas-PCA.com](mailto:Editor@Carolinas-PCA.com)

P. S. I still use double spaces, but did find and replace to remove them :)



**Goodie Store**  
Kathy Boehm • 336.566.7501 • KathyABoehm@gmail.com

**NEW** **Moisture Wicking T-shirts**  
Ladies and Men's  
Email or call to place your order.

**PCA** Name Badge  
CAROLINAS REGION  
Order your PCA Name Badge today by email

Come visit the Goodie Store at:  
**THE Goodie Store**





# Driver's Education:

By John Babinski



## Winter Seminar

On Sun. Jan 10<sup>th</sup> we held our annual Drivers Education Winter Seminar at Carolina Motorsports Park (CMP) in Kershaw, SC. This event was an educational opportunity for members interested in learning more about the driver's education program before actually attending a track event. We had a great turnout with over 35 attendees participating. The classroom session was

used to outline several key areas of the DE program to make the first track experience for new participants less daunting. We covered the basics of what is a DE, what is required to participate, what is included in a tech inspection, how to go about signing up for a DE, the schedule for a typical weekend, where we hold DE's, etc.

Once the classroom session was completed the real fun began. The weather gods cooperated with a sunny and cool day providing good track conditions. Since CMP had no other events scheduled that day they allowed us to take small groups of cars on parade laps around the track. This allowed everyone to see and feel for themselves the layout and flow of the track. While half the participants were on track our Chief Instructor Shane Tisdale had the other participants involved in a mock technical inspection of a car. Then we swapped groups so everyone got a chance to ride the track. Participants also got a chance to see 2 of Porsche's hottest new track toys as Tom Arkle brought his just delivered GT3RS and Jim Buchanan brought out his new GT3 to help out as lead/follow cars during the parade laps.

Based on the smiling grins of drivers coming off track it looks like we were able to "set the hook" in a few of the attendees. Several have already

signed up for our first DE of the season.

Our Drivers Education series for 2016 includes the following confirmed events:

March 12-13. DE at Carolina Motorsports Park

Sept 24-25. DE at Carolina Motorsports Park

Nov. 18-20 DE at VIRginia International Raceway (Fri. is a solo only day)

We are still working to add one additional event in late spring/early summer at an alternate track location.

In addition, we will once again be holding our PCA National Certified Instructor School. Shane Tisdale, our Chief Instructor, will be conducting the training on Fri. March 11 at CMP.

Information for all these events can be found at [www.clubregistration.net](http://www.clubregistration.net)





# Area Updates: Jan 2016

## Triad Area By Jerry Kilcrease



**Meeting:** Third Tuesday of the month at 7:00 PM  
River Ridge Tap House, Clemmons NC  
Contact Jerry Kilcrease, Area Director  
[triad-ad@carolinas-pca.com](mailto:triad-ad@carolinas-pca.com) (336) 476-3120

The Triad Area had 57 members and guests attend the January 19<sup>th</sup> monthly meeting at River Ridge Taphouse in Clemmons. Ron Reed provided overhead photographs and Rick Huskins worked the 50.50 charity split the pot table. When the winning ticket was drawn it belonged to visiting Howard Wasserman. Rick Huskins, Charlie Massler and Steve Showalter celebrated birthdays in January and were treated to a desert as the group sang "Happy Birthday". Howard Wasserman, who is the author of TR's "Hysterical Ramblings" drove down from the Triangle Area to present the 2015 Trivia Award to winner Charlie Massler and T. J. Gottwalt received his trophy for winning overall in his class during the 2015 Carolinas Region Autocross Series. Scott Owen of Porsche of Greensboro, discussed the upcoming Tech Session to be held at their facility in Greensboro on February 27<sup>th</sup> and Charlie Massler outlined plans for the June 24-26 Roads and Rails Charity Drive. Thanks to all that came out...we hope to see you at the February monthly meeting...and bring a friend.

**TRIAD AREA 2015 CHARITY DONATIONS:** The Triad Area PCA membership is always very active when it comes to supporting local charities. In 2015 we hosted a variety of events that resulted in donations to the American Children's Home in Lexington, NC, YMCA Camp Hanes in King, NC and the Greensboro Urban Ministries Food Bank in Greensboro. At each meeting we hold a 50/50 charity split the pot drawing where one half goes to the lucky ticket holder and the other half goes into our charity fund. In 2015 the Triad Area donated a total of \$10,990.50 to local charities. Congratulations to the Triad Area membership!



## UP COMING TRIAD AREA HOSTED EVENTS:

**TECH SESSION – SATURDAY, FEBRUARY 27<sup>TH</sup>** – The Triad Area will host a tech session at Porsche of Greensboro from 9:00am until noon on Saturday, February 27<sup>th</sup>, 2016. Scott Owens, Porsche Technician, will perform a typical "front end alignment" and will explain the step by step procedure and answer all questions as he goes through the process. Coffee and doughnuts. If you are planning to attend please RSVP at [jkilcrease@triad.rr.com](mailto:jkilcrease@triad.rr.com) or by phone at 336-847-9292 so I can get a head count. This is our first event of 2016 so come out and join us.

**PROPOSED 2016 TRIAD AREA HOSTED EVENTS:** Complete details on the events listed below will be coming later. Please contact me at [jkilcrease@triad.rr.com](mailto:jkilcrease@triad.rr.com) if you have any questions or comments.

- February 27 – Tech Session – hosted by Porsche of Greensboro
- May 21<sup>st</sup> – Porsche Corral @ American Children's Home Car Show Charity Event
- June 3<sup>rd</sup>-5<sup>th</sup> – "Explore Blowing Rock Drive" – Bill Suite/Rick Huskins co-chairs
- June 23, 24 & 25 – Roads and Rails – Camp Hanes YMCA Charity Event
- July 9<sup>th</sup> – Three Area Drive/Dine/Car Show (Triangle/Sandhills/Triad)
- July/Aug (date TBD later) – TSP Fun Rally – Dave Lumpkin, Chairman
- July/Aug (date TBD later) - John Robinson Memorial Family Picnic/Shine & Show
- October (date TBD later) – Oktoberfest – Porsche of Greensboro, Sponsor
- December (date TBD later) – Christmas Party

## NEXT TRIAD AREA MEETING – TUESDAY, FEBRUARY 16<sup>TH</sup>, 2016

The Triad Area will hold its next monthly meeting on Tuesday, February 16<sup>th</sup>, at the River Ridge Taphouse in Clemmons. We start socializing around 6:30pm and start our dinner business meeting at 7:00pm. Please make plans to come and join us....and bring a friend. Thanks, hope to see you then.



## Metrolina Area by Laura Varney



**Monthly Meeting:** Third Wednesday of the month at 7:00 PM, see report for location. Contact Laura Varney Area Director [metrolina-ad@carolinas-pca.com](mailto:metrolina-ad@carolinas-pca.com)

The Metrolina Area Christmas Party was held on December 16t at Maggiano's Little Italy in the Southpark area. One of our very own PCA Members, Antonio Tillery, who works as the Mid Atlantic Area Director for Maggianos, provided a great setup for our event which was a complete success, with private parking, family style dinner and a cash bar. This was a sold out event with 70 members in attendance and a waiting list for which we could not accommodate all. However we are already looking into options to support a larger event for 2016.

This party could not have been as successful without the generosity of our sponsors who were Continental Tire, Hendrick Porsche, GMP Performance, Exclusive Motorwerks, Maggiano's, Sunstoppers, Curve Appeal Detailing, Porsche Memorabilia and Coco Mats, USA. These donations represented a grand total of just over \$7,000 worth of prizes that were either auctioned or raffled off! Below are some of the highlights:



**Rich Wittholt** was the Male Member recognized for his brand passion and involvement with the Club throughout the year. He was awarded a very nice PCA Driving Shirt.

**Cindy Briggman** was the new Lady Member of the year and was surprised with a marriage proposal from Greg Konney. Congratulations!

**Claude Simmons** and **Mats Herrstromer** bid the highest for the two Porsche Driving Experiences donated by Hendrick Porsche

**Laura Varney** was the highest bidder on a new set of Continental Tires with a mounting and balance donated by GMP Performance.

**Seth Werner** won the complete Clear Bra for his new Porsche.

**Warren Snowden, Tracy Gentry** and **Jim Buchanan** won the Window Tinting packages.

**Harvey Yancey** and **Duane Stanek** each won a set of Coco Mats

We were able to raise \$3,485 to benefit the

Second Harvest Food Bank, bringing our 2015 contribution in the amount of \$5,760.00! The Second Harvest Food Bank of Metrolina supplies food and grocery items to charitable agencies that assist people in need supporting 14 counties in the Carolinas.



# WE BUY PORSCHESES!!



Visit our Showroom located in the Mooresville NC Racepark  
292 Rolling Hill Rd. Mooresville, NC 28117  
Call John Cleveland @ 704-907-7587 | [porsche@ppi911.com](mailto:porsche@ppi911.com)

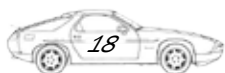

## Triangle Area By Howard Wasserman



**Monthly Meeting:** Fourth Tuesday of Month  
Tobacco Road Sports Cafe  
1118 Environ Way, Chapel Hill 27517  
Contact Howard Wasserman, Area Director  
[triangle-ad@carolinas-pca.com](mailto:triangle-ad@carolinas-pca.com) (919) 538-0202

### Make-A-Wish, our area charity

Make-A-Wish has some volunteering opportunities. For instance, my wife and I are in the process of qualifying as Wish Granters. To see all the volunteering opportunities, go to [eastnc.wish.org](http://eastnc.wish.org). If you have any questions, contact me or Julie Berry, Volunteer Coordinator at Make-A-Wish at [jberry@eastnc.wish.org](mailto:jberry@eastnc.wish.org).

### List of Events for 2016 — Tentative

Two tech sessions: Still struggling to get commitments from hosts. If you have any tech session locations to suggest, please do so.

Third Annual Old Homestead Fall Gimmick Rally and Brunch – new end location

Day trip to the NC Museum of Transportation

Three Drive & Dines including one BBQ Run and one Ice Cream Social

Third Annual Tri-Area Spring Drive & Dine, Shine & Show – July 9 is the date. Destination TBD

Possible group journeys to

Pinehurst Concours

Region's Sommerfest multi-event weekend

Region's Fall Tour

If you have any ideas for events or would like to help organize any events, please let me know.

Following are the Area's recurring events.

Monthly **Cars & Coffee** on the third Saturday of the month to be held at Panera Bread, Patterson Place, 3603 Witherspoon Blvd, Durham 27707. The next meetup is **Saturday, February 20** starting at 8:30 am. Don't let inclement weather deter you—just bring your daily driver.

Monthly **Dinner Meeting** on the fourth Thursday of each month at the Tobacco Road Sports Café, 1118 Environ Way, Chapel Hill, 27517. The next dinner is **Thursday, February 25** at 6:30 pm.

To be kept current on Triangle Area events, consider joining our meetup group. <http://www.meetup.com/Triangle-Area-Carolinas-Region-PCA/>. If you're not getting my periodic emails about events, please send your email address to [triangle-ad@carolinas-pca.com](mailto:triangle-ad@carolinas-pca.com)

## Hickory Area By Michael Vittorria



**Meeting:** Second Tuesday each month at 6:30 PM  
Refer to Monthly Area Report for Location/Detail  
Contact Michael Vittorria, Area Director  
[hickory-ad@carolinas-pca.com](mailto:hickory-ad@carolinas-pca.com)

Though attendance at our January meeting was a bit smaller than we have come to expect, a good many of our more frequent attendees were present to offer feedback and ideas for our upcoming year.

A proposed calendar of activities was presented for discussion, a few highlights of which include:

- Saturday activities - in order to encourage attendance of those members for whom an evening meeting may not be convenient, four of our 2016 meetings will be held on Saturdays. Three of these will be sponsored and held at Porsche of Hickory and will be followed by a Drive and Dine event. The fourth will be in August and will be a repeat of last year's popular Picnic at the Lake.
- Vendor sponsorship - several of our 2015 dinner meetings were combined with "tech sessions" sponsored by and held at some of our local vendors. In 2016, three of our evening meetings will be of this variety. The first will be in March at K&M Collision. The other two will be announced in the next few weeks.
- Charity - we would like to see an increase in our Club's charitable contributions. One avenue we are exploring is creation of a charity "Shine and Show" car show in conjunction with one or more of our sister Areas based in Greensboro and/or Charlotte. Though Porsche of Hickory has signed on as a potential sponsor, this project is very much in its formative stages. We are also reviewing our options as to which charities the Club will support in the future.
- Fall Tour - the Hickory Area will once again organize the Carolinas Region Fall Tour. Though plans continue to evolve, it is expected that the Tour will travel to Western NC for a three day driving event sponsored once again by Porsche of Hickory.
- Holiday Party - last year's Holiday/Member Appreciation event at Lake Hickory Country Club was a great success. We intend to do our best to repeat this event in 2016.

I hope you will agree that 2016 is shaping up to be an exciting year for the Hickory Area. When combined with activities sponsored by other local car clubs, our Region and our sister PCA Areas, there will be something of interest to "car people" almost every weekend. As in 2015, I will send you monthly summaries of upcoming events in our area. I sincerely hope you will join us.

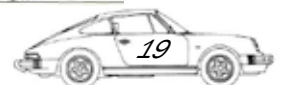
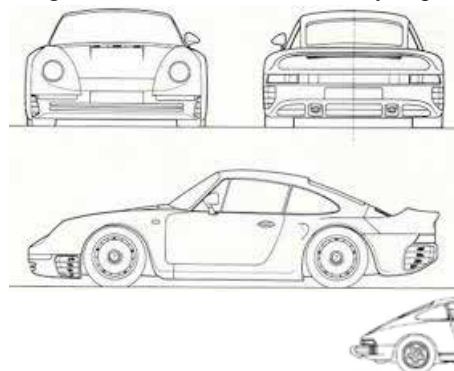

## Sandhills Area By Marty Barrett



**Meeting:** Fourth Tuesday of the month at 6:30 PM  
Rotating Location - See report below  
Contact Marty Barrett, Area Director  
[Sandhills-ad@carolinas-pca.com](mailto:Sandhills-ad@carolinas-pca.com)

Reflecting on 2015, Sandhills had a very good year. Participation at dinner meetings continues to grow...now averaging 35. And, in August we went from a meeting every other month to monthly meetings. With the region realignment, Sandhills membership more than doubled to 165.

We enjoyed great participation from Sandhills, and other Carolinas region members, planning and conducting Sommerfest in Pinehurst. Mike Jones and Mike Rich were an incredible help putting together the concours. Sadie Kilcrease, to no ones surprise, kept tabs on the budget and spending for Sommerfest that lead to a financially successful event. Without the sponsorship and financial support from Tom Holderfield and Porsche of Fayetteville, there would not have been a Sommerfest. And, Marvin Waters and his team at Little River resort did a great job.



Larry Wolff and Mike Ascher managed charity raffles which generated \$1907 from members and \$500 matching from PCA. This allowed us to fund a full one year scholarship at Sandhills Community College. Larry & Mike ran the golf skills challenge at Sommerfest, and Larry set up our tour and lunch to Carrboro.

Bill & Barbara Ainsley, our outstanding Sommerfest rally masters, also planned a great route to Helen, Ga.; and Bill conducted a tech session at his garage/shop. They are both volunteer leaders at the Pinehurst Concours. Marvin and Vera Jennings helped in many aspects of planning and administration

at Sommerfest, initiated and planned the Helen, Ga. event; and they both, along with my wife BJ, put in many hours supporting the Pinehurst Concours. Keefer Welch planned the driving tours for Sommerfest and volunteered for field operations at the concours. My sincere thanks to all those who helped make 2015 fun and successful for Sandhills Area.

2016 is off to a great start....five of us went to Roebling Road Raceway Jan 15-17 to drive in Florida Crown region DE. Kenny Bumgarner and son Tyler shared the 991 C4S. It was Ty's 1st DE and he was grinning ear to ear all weekend! Next is our visit to the Ingram Collection on Jan 30; thanks to Rory Ingram for the invitation. The event filled very quickly and we are looking for another date in late spring or summer. A few of us are now working on detailed plans for a tour to Kentucky's Bourbon Trail in April. And, Porsche of Fayetteville is hosting an introduction event for the 2017 Carrera turbo in March.

The 2016 Pinehurst Concours is Saturday, April 30 at the Pinehurst Resort. Fifty (50) PCA Porsches are registered to display on the fairway adjacent to the judged classics. And, Friday evening there will be a Porsche PCA & Corvette Club display in The Village of Pinehurst along with music, food, drink, etc.

Things are busy in Sandhills Porsche country! I'm excited about visiting the Porsche Experience Center in early February.

**Bertil Roos RACING SCHOOL**  
1-800-722-3669  
WWW.RACENOW.COM  
CUSTOMERSERVICE@BERTILROOS.COM

**2016 DATES**  
March 2-6 3 Day Road Racing School  
March 10-12 2 Day Summer School  
March 13 2.5 Day Road Race 2 1999 Hours  
March 12-13 2 Day AM, PM & 1 Day School

**Ask About PCA Member Discounts!**

**REASONS TO GO TO ROOS**

- Professional Instructors
- Complete Arrive & Drive
- No Artificial Speed Limits
- Passing Allowed
- Open-wheel Cars

**SCCA Licensing School**

**Other Locations**  
Pocono Int'l Raceway • New Jersey Motorsports Park • Roebling Road Raceway  
1-800-722-3669 • WWW.RACENOW.COM • CUSTOMERSERVICE@BERTILROOS.COM



## Upstate Area By John Budinich



**Meeting:** First Monday of the month at 6:30 PM  
Quaker Steak & Lube  
10 Chrome Drive Greenville SC  
Contact John Budinich, Area Director  
[upstate-ad@carolinas-pca.com](mailto:upstate-ad@carolinas-pca.com) (864) 915-0011

As we kick off a new year, we seem to be picking up where we left off at the end of last year. Meeting attendance was strong for a January with 55 people in attendance. We had three new, first time attendees and interest in local activities appears strong.

### *Upstate Area Christmas Party & Member Appreciation Event*

As I mentioned in last month's report, the annual Christmas Party and Charity Auction was a HUGH hit. We had 110 people in attendance and there was more than enough food and drink for everyone. I would like to once again thank John Perkins for providing the facility and beverages for the event and Shane Tisdale for again acting as lead auctioneer. Shane sure knows how to keep the auction moving and how to get everyone in the holiday spirit of giving for charity.

The auction is the centerpiece of our year-long charity fund activities and has been a staple in the Upstate Area for many years. We collected a number of items for the auction donated by PCA members, Protech Motorsports, Porsche of Greenville and other local businesses. Items ranged from car-related gifts and parts, original paintings, tools, a ceiling fan, wine, Porsche Design clothing, service certificates and so on. We even had three VERY large canvas posters, with mounting hardware that were in the Porsche of Greenville showroom prior to their recent remodel. Now that's garage art!

Continuing the Upstate Area's rich tradition of raising money for those in need at our Annual Christmas Party, this year blew away all expectations. This year's auction alone raised \$21,130 and through a combination of our monthly 50/50 raffle, other charity-related activities and the Christmas Party Auction, we raised a total of \$24,009 in 2015. We once again donated these funds to the Society of St. Vincent DePaul. At the January meeting, David Anderjack of the Society of St. Vincent DePaul spoke to the group and described how the funds raised were utilized. To that point, assistance was given to 95 families in the following manner.

10 families had their power reconnected (includes payments, late fees and service charges)

23 families were able to avoid having their power cut off due to final notices

28 families were assisted in making late payments

The balance of the 95 families were assisted in payments covering electric, gas, water and food

David also mentioned that they forecasted the donation would last another two weeks and in the end, over 100 families would have been impacted by our contributions. David also reiterated that the Society of St. Vincent DePaul is 100% volunteer run and every penny of the donations they take in goes out to assist families in need. There is no overhead or administration fee taken out of the donation to run the charity. He also mentioned that these are not "gifts," as the receiving families must participate financially as well. David's final comments lightened the mood in the room. He stated the Porsche Club made it a bit difficult on them, as we have doubled our contributions year over year for the past three years, increasing their efforts in vetting appropriate

families to assist over the holidays. This is a burden David and everyone in the room enjoyed having to deal with.

It's that time of year. Get out your chili pots and your "secret" recipes. The annual Protech Chili Cook-Off will take place on

### *Annual Protech Chili Cook Off*

Saturday, February 13 starting at 6:00 PM.

Be sure and bring a large spoon for your chili pot or no one will be able to taste your entry. If you don't want to bring chili, a dessert or appetizer would be great! Chili judging will begin at 7:00 PM. There will be judging for both the best chili and the best dessert. The party will be BYOB but Protech will provide soft drinks & water, as well as the cups, bowls, plates and utensils.

The address for Protech Motorsports:  
917 State Park Road Greenville, SC 29609

Please RSVP to [upstate-ad@carolinas-PCA.com](mailto:upstate-ad@carolinas-PCA.com) by Saturday, February 6 so Bill & Frank can plan accordingly. Remember to bring your appetite and maybe some antacid, as some of the chili may be HOT!

We are now using Mailchimp for local, Upstate Area

### *Reminder: Upstate Area of Carolinas Region PCA Email Distribution List*

communications. We want to capitalize on this opportunity to build a more complete and accurate distribution list. This effort will ensure we reach all Upstate Area members, both existing and new, who are interested in receiving updates on local activities. Complete instructions on how to opt in to the email distribution list are in last month's Tobacco Roads in the Upstate Area report. If you have any questions, feel free to email me at [upstate-ad@carolinas-PCA.com](mailto:upstate-ad@carolinas-PCA.com).

### **Upcoming Upstate Area Meeting**

Monday, February 1 at 6:30 pm at Quaker Steak & Lube, Greenville, SC

Monday, March 7 at 6:30 pm at Quaker Steak & Lube, Greenville, SC

Monday, April 4 at 6:30 pm at Quaker Steak & Lube, Greenville, SC

As always, I would ask members to keep the ideas, suggestions and feedback coming to [upstate-ad@Carolinas-pca.com](mailto:upstate-ad@Carolinas-pca.com) as they can only help to improve our meetings and activities throughout the year. --- John



**GIRLS in Porsches** By *Sadie Kilcrease*



**Meeting:**  
 Rotating Location and Times  
 Contact Sadie Kilcrease (Editor's Note )  
[sadie.k@triad.rr.com](mailto:sadie.k@triad.rr.com) 336.847.9293



*The* Triad Area Girls In Porsches held their final meeting of the year on December 9. While we normally meet at various restaurants located within the Triad Area, member Tomi Jacobowitz invited us to their new home in Whitsett for our

Christmas meeting. What a beautiful setting, acres of green pastures, with white fences and horse farms surrounding the area. After a tour of Tomi and Sam's new home-- complete with swimming pool and a 6 car garage, we enjoyed a variety of dishes prepared by the members and our hostess.

*Our* GIP group was formed in March, 2009, to offer the ladies in the Triad Area PCA an opportunity to relax, socialize and enjoy "girl talk." In addition to having fun and discussing current and upcoming PCA Events, we also raise funds for charity. At each event we have a 50/50 Raffle with the pot amount going to charity. Contributions are made to local charities such as The American Children's Home in Lexington and YMCA Camp Hanes. I would like to thank all the ladies that have supported the GIP group. In addition, we would like to invite the ladies in the Triad Area and the Carolinas Region to join us if you are in the area.



*Our February meeting* will be held on Wednesday, February 3 at Green Valley Grille located at the O'Henry Hotel in Greensboro.

Hope to see you there. Please email or call if you are interested in joining us or would like to be added to our email distribution.

## Porsches & Parts

**Notice: Caveat Emptor.** Neither the Carolinas Region-PCA nor the Editors (Carolinas Region) endorse, guarantee or have, in any way, screened, verified or attest to the veracity of the following ads. The Carolinas Region makes no warranties, express or implied, with regard to any advertised goods or services. Buyers should practice due diligence.

Additional information on all classified ads can be found by either contacting the seller or checking our website for photos at [www.carolinas-pca.com](http://www.carolinas-pca.com).

### Porsches

**1983 944 :** Red. Black interior. 212K. Owned 19 years. Runs and drives nicely. All service records since owned. Lowered with 17" Cup Mille Miglia Cup 2 wheels. Rear tires 255/40/ZR 17 Yokohama - 75% tread. Front tires 225/45/ZR17 Falken - new. New clutch and Bilsteins 8.5 years ago. Timing chain, tensioner & gaskets at 195K miles. Crankshaft position sensors and wiring Oct 2015. Dash cap cover. Momo steering wheel. Aftermarket racing style seats. Front bumper shaved. 89S rear end/transaxle. Sony AM-FM stereo CD-MP3 player with iPhone input and remote. Cold air. All original mats, cargo cover, tool kit, Porsche owners manual, sunroof bag and spare. New spare clock. Spare used white front nose. Carpet looks great. Needs paint. I've put 88K miles on it since purchased. Never tracked. Originally sold new at Cannon Porsche in Greenville, SC. Serious inquiries only. Pix available on re-

quest. Contact: Jeff Gandy, Greenville, SC  
 email: [quickonamac@yahoo.com](mailto:quickonamac@yahoo.com) Phone: 864-901-5615

**2004 911 Turbo Cabriolet:** \$58,500. VIN WPOCB29994S675862. Pristine 2004 911 Turbo Cabriolet Artic silver metallic with black leather. 20,500 miles, impressive X-50 option (\$18,000), 18" Sport Techno, heated seats, crest, yellow brake calipers, instrument dials yellow, red, white, blue, sport seat backs painted, alum/leather shift/brake, new tires. Almost all options except ceramic brakes. MSRP \$158,000. Recently replaced clutch press plate and ORVR valve (4,000). 2nd owner for 8 yrs. Contact: Charles Duffey, Lexington, NC email: [cddrph@outlook.com](mailto:cddrph@outlook.com) Phone: 336-408-3006



**2008 987 Boxster:** Guards Red with Sand Beige Leather and Black Top. VIN:WP0CA29818U710074. Very clean and fully loaded with Power Seat Package, Glass Windstop with storage bag, Tiptronic S, 18" Boxster S Wheels with colored crest caps, self-dimming mirrors with rain sensor, heated front seats, coco and factory floor mats, interior storage box and Sound Package plus. All service records. 7K gentle miles on Michelin Pilot Sport Tires. \$24,900. Contact: Tom Ruff, Asheville, NC email: [truff@biltmore.com](mailto:truff@biltmore.com) Phone: 828-225-6105

**2008 Porsche Boxster Limited Edition:** 46,500 miles - \$25,250. Current CarFax. Dealer receipts. Contact: Ron Larkin, Charleston, SC email: [lvmyks@gmail.com](mailto:lvmyks@gmail.com) Phone: 206-713-3773

---

## Parts – Parts Cars – Projects

---

**Cayman Roof Transport System:** fits all 987 Caymans. Four mounting posts and two cross bars. Made by Yakima, but fits OEM roof mounting points exactly. Might deliver, depending on location. \$200 or best acceptable offer. Contact: James Hill, Pinehurst, NC email: [jhpilot1@gmail.com](mailto:jhpilot1@gmail.com) Phone: 910-215-0978

**4 x 18" turbo wheels:** 4 turbo wheels 18" MILLEMIGLIA Cup Wheels made in Italy, fair condition 18 x 8.5 front, 18 x 10 rear, 4 Michelin sport cup tires mounted, 2 weekends front, 1 weekend rear - \$600. Contact: Gary Hediger, Greenville, SC email: [ghediger@hedigerconsulting.com](mailto:ghediger@hedigerconsulting.com) Phone: 864-787-5961

**Roll bar for 996NS:** DAS Bolt-in roll bar for 996NS, flat black powder coated \$700. Contact: Gary Hediger, Greenville, SC email: [ghediger@hedigerconsulting.com](mailto:ghediger@hedigerconsulting.com) Phone: 864-787-5961

---



---

## Wanted

---

**Roommate Wanted:** Roommate wanted for Adrenaline Adventures with Fast Lane Travel, Inc. Sept. 15-24, 2016, from Stuttgart, Germany. Includes new Porsche, gasoline, insurance, lodging, meals, drinks, tours of Porsche & Mercedes Museums, Porsche factory tour, stunning alpine roads, autobahn 150 MHP Club. See Pano ads, [www.FastLaneTravel.com](http://www.FastLaneTravel.com) or 813-343-3003. Hoping to avoid solo supplement \$\$ & share adventures. Please contact Sven at Fast Lane Travel (813) 343-3001 or me to discuss. Contact: James Proper, Charlotte, NC email: [jamesproper@carolina.rr.com](mailto:jamesproper@carolina.rr.com) Phone: 704-545-0543

---



---

## Non Porsche

---

**Audi Avant Rack:** Audi A4 Avant roof rack system with bicycle carrier. Bike carrier never used. Still in box. Fits an Avant 2009 through 2013. \$400.00. Contact: Gary Agardy, Greenwood, SC email: [gagardy9@gmail.com](mailto:gagardy9@gmail.com) Phone: 864-344-1965

**2009 Honda DN-01 motorcycle:** Slightly over 4000 mi. Over \$18000 invested; all service records; Givi accessories (saddle and upper removeable bags) and windscreen; dual transmission (manual and automatic); anti-lock brakes; black with red striping; beautiful cond. Asking \$8500. Bike has to be seen at my house. I have removed insurance. Contact: Bob Graf, Ninety Six, SC email: [graf96@embarqmail.com](mailto:graf96@embarqmail.com) Phone: 864-543-2224



North Carolina's Authority for European Auto Service & Repair

BMW | Mercedes-Benz | Porsche | Audi | VW | MINI | Land Rover | Jaguar | Volvo | Saab | Fiat | Alfa Romeo | Maserati

Service interval 3.

Oil change in: 900 mi

- Porsche Maintenance
- Factory Warranty Approved
- Bosch Authorized Center
- Custom Services Available
- Basic Oil Service to Major Repairs
- Classic 911's through 991+
- Cayman & Boxster
- Cayenne & Panamera

- Preferred IMS Installer
- Single Row Pro Retrofit
- IMS Solution Available
- Barcoded Bearing Registration
- Pre-Qualification Procedures
- Correct Engine Oil
- Get it Done Right

Club Member Discounts

Shuttle/Pickup-Drop off Service

Loaner Vehicles Available

Maintain Factory Warranty

3<sup>rd</sup> Party Warranties Accepted

Bosch Certified Repair Center

Factory Tooling & Software

3 Year, 36k Mile Warranty

Veteran Discount



Italian American Owned & Operated. Cupari Solutions, LLC dba Carmine's Import Service 2015 All Rights Reserved

[www.carminesimportservice.com](http://www.carminesimportservice.com)



**Tobacco Roads**

Robert Rainer, Editor  
Carolinas Region – PCA  
728 Plume St  
Spartanburg, SC 29302

PRSR STD  
U.S. POSTAGE  
PAID  
PERMIT #34  
GREENSBORO, NC  
27405



**WE WANT YOU!**

**To Write & Photo  
For Tobacco Roads**

Contact  
[editor@carolinas-pca.com](mailto:editor@carolinas-pca.com)

