

Feb. 2021



Tobacco Roads



The monthly newsletter of the Carolinas Region Porsche Club of America



Vier Generationen: The Boxster turns 25, and four TR members share their stories

Plus ... Rob and Debbie win the PCA Winter Raffle. ('Driver's Seat,' p. 3)



2.21

IN THIS ISSUE:

DRIVER'S SEAT | VIER GENERATIONEN | AREA REPORTS
DRIVER'S ED | EVENTS | CLASSIFIED LISTINGS



Building relationships one car at a time.

Independent Porsche Service, Sales, Performance, Detail & Transport

Experience the Difference



Nationwide Sales

Tel: 336 978-8818

www.hbiauto.com

info@hbiauto.com

 [hbiauto](https://www.facebook.com/hbiauto)  [hbi_auto](https://www.instagram.com/hbi_auto)



From the Driver's Seat

Jerry Widner, President



And there goes January! One more month closer to warmer weather; how many of you just shook your head “yes”? Our PCA story goes like this:

While a Marine Corps Drill Instructor down at Parris Island, SC back in 1997, I purchased a 1987 944S. 5 speed, Guards Red, Linen interior...44k miles, 16” Flat Dish Wheels...it was in near perfect condition. What a blast to drive! I had always loved the shape and design of the 944s and 928s – long hoods, curvy lines; it was the car I was looking for. We had just moved into our new home and the morning of our telephone (yes, we used to have land lines) and cable install became a turning point moment.

Our Cable Guy (not to be confused with any Jim Carrey characters) pulled up in his company van and proceeded quietly and quickly to install the equipment/lines we needed. It wasn't until after the install, that he asked me about my Porsche. He asked if he could look it over and commented on how nice it was. During our conversation he asked if I were a PCA member. I responded with “a member of what?” so that pretty much told him the answer. He introduced himself as Dan and shared the story of his 1979 911 SC that he had just rebuilt and takes to the track at Roebing Road.

Dan had to go to another call, so I thanked him for the install and great service then we parted ways. The next day; Saturday morning bright and early...I hear an air-cooled symphony outside. Opened the front blinds and alas Dan was sitting in his 911...in my driveway. We've been friends ever since; and have built some very cool projects along the way.

So as the saying goes; “It's not just the cars...it's the People”. True and to the point, a conversation that started out about a car...has turned into an almost quarter century friendship. We joined PCA shortly thereafter and attended some track events with Dan at Roebing Road and VIR. We also participated in numerous family picnics held along the Coast; it was a great first impression of nice, friendly people. ...to be continued....

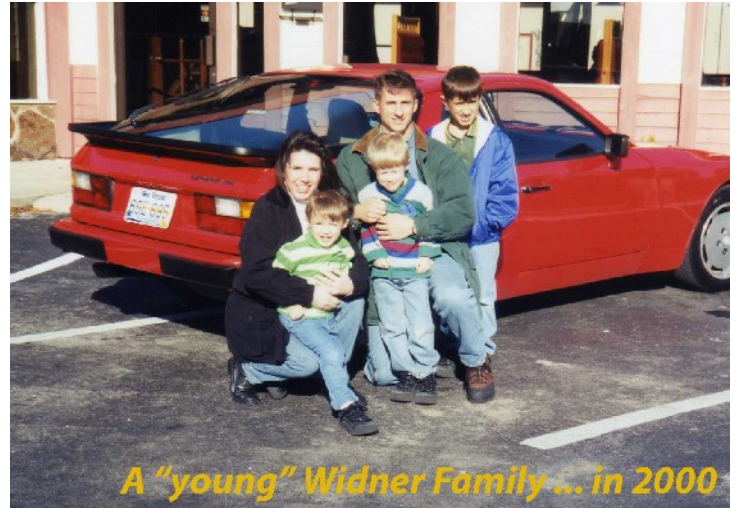

Speaking of THE PEOPLE, I want to give a special thanks to Rory, John, Fred and Rob for taking the time to meet at Southpoint Porsche (Durham) on a Saturday afternoon for a photo shoot on the Four Generations of Boxster; in this case all of the “S” variant. We had a great time talking and looking over each other's cars. You'll see the results of our Seriously Six Symphonic Saturday “S” Shoot on my first “Presidents Project Page” further into this issue.

Little did anyone know that also during the event we had a special giveaway; one of your very own Carolinas Region members had just won the PCA Members Only, Winter Raffle. Rob and Debbie were stunned and shocked as Ann and I broke the news to them of their winnings – Congratulations again on the 2021 911 Targa 4S! Henceforth, I'll refer to you as “Raffle Rob”! It has a nice ring to it...right?

Special mention to Mike, from the Hickory Area for using his own 911 Targa 4S as the “stand-in” car as well as presenting a ceremonial “key” to Rob and Debbie. He also welcomed them to the Carolinas Region Targa club (no such club...but you get my drift?).

So, for those of you that didn't buy tickets for the winter raffle, Ann says don't forget to buy your tickets. Next time...you could be the lucky winners!

By the time you are reading this, you should have or will be receiving some survey questions as it relates to our Region. Please take the time to answer as honestly as you can; remember, the only wrong answers are those not provided.

As I pointed out in last month's letter as well as a few additional items, here a few things we are working on for the Region:

- New YouTube Channel content
- Street Survival Driver Training
- Visibility in Panorama Magazine
- 4x4 SUV Events (That's right you Cayenne and Macan owners, it is time!!)
- Presidents Project Page (1st installment, here...this month)

Opening on the Regional Support Team:

Advertising Chair – if you are interested please email our Vice President, Jim Hess, he will be glad to speak with you about this opportunity.

I ask that you look through the pages here and find AT LEAST ONE event to attend. We have the BEST roads around...the BEST people around...the BEST FAMILY around. Happy Valentine's Day!! Enjoy!

Here to serve You...and remember; Get Out And Drive!!!

Jerry Widner sends...
Carolinas Region, President
Semper Fi!



INBOX or MAILBOX



Whether you receive the hard copy or opt for electronic only, the digital option is always available on the region's website.

To Opt out of receiving printed copy—there are 3 options:

Call PCA at 410-381-0911

Email PCA at admin@pca.org

Go to www.pca.org, login and Edit your personal information, scroll down to bottom and check "Opt Out of printed newsletter". You must go all the way to bottom and hit SAVE.

Recurring Cars and Coffees & Shine and Shows By Area:

Metrolina Area

2nd Saturday: 9 am to 11 am Stuttgart Saturday hosted at Hendrick Porsche

Triangle Area

3rd Saturday Monthly: 8:30AM, Panera Bread Patterson Place S/C 3603 Witherspoon Blvd Durham, NC 27707

Hickory Area

None at this time

Lake Norman Area

2nd Saturday: 8:00 - 10:00

- Waterbean Coffee in Cornelius

- Stuttgart Saturday - 9:00 - 11:00 at Hendrick Porsche

Triad Area

TBA

Upstate

4th Saturday Monthly: 8AM to 11AM, Michelin North America Headquarters 1 Parkway South & Pelham Road Next to Marriott Hotel Intersection of Pelham Road and The Parkway at Exit 54 of I-85 in Greenville, SC.

Contents

Departments		Advertisers Index	
Member Anniversaries	4	Burton Shocks	18
New Members	5	Carmine's Import Service	8
Area Calendar	6	GMP	20
Region Officers and Board	7	Goodie Store	17
Triad Area Update	9	Hagerty	17
Sandhills AD Update	9	HBI Auto	2
Lake Norman	10	Jason Herman Insurance	16
Metrolina	10	Porsche of Greensboro	19
Hickory Area Update	11	Porsche of Hickory	19
Triangle AD Update	11	Porsche Prospector	6
Upstate Area Update	12		
Drivers Ed	13		
President's Project Page	14		
Area Classified Ads	18		

New Members and Anniversary Memberships

The Carolinas Region would like to welcome new members and transferring members. In addition, we would like to congratulate members celebrating anniversary memberships this month for five, ten, fifteen, twenty, thirty, or more years of PCA dedication.

January Anniversaries

Last Name	First Name	City	State	PCA Carolina's Area
35 year anniversary				
Michalek	Kenneth	Greer	SC	Upstate
25 year anniversary				
Peters	Richi	Whitsett	NC	Triad
Peters	Gus	Whitsett	NC	Triad
20 year anniversary				
Creasman	Christopher	EASLEY	SC	Upstate
Creasman	Parker	Easley	SC	Upstate
Cuccia	Steven	ADVANCE	NC	Triad
Cuccia	Mike	ADVANCE	NC	Triad
Rogers	Frank	WEDDINGTON	NC	Metrolina
Rogers	Yohanna	Weddington	NC	Metrolina
Schlueter	Raymond	Mooreville	NC	Lake Norman
Schlueter	Masako	Bartlett	IL	NONE
10 year anniversary				
Ainsley	William	Pinehurst	NC	Sandhills
Ainsley	Barbara	Pinehurst	NC	Sandhills
Ayache	Serge	South Port	NC	Triad
Baker	Curt	Concord	NC	Metrolina
Baker	Winfred	Concord	NC	Metrolina
Burkett	Sue	Southport	NC	Triad
Dickerson	Shirley	Galax	VA	NONE
Strup	Nathaniel	Greensboro	NC	Triad
Suite	William	Galax	VA	NONE
Taylor	Wes	West Columbia	SC	Upstate
Taylor	Candy	Chapin	SC	Upstate
Thomason	John	CHAPIN	SC	Upstate
5 year anniversary				
Braun	Ted	Indian Land	SC	Metrolina
Duskin	Leo	Salisbury	NC	Metrolina
Folds	Cheryl	Winston Salem	NC	Triad
Gibson	Chuck	Gastonia	NC	Metrolina
Granelle	Eugene	Mooreville	NC	Lake Norman
Howell	Janice	Salem	SC	Upstate
Howells	David	Salem	SC	Upstate
Marchese	Anthony	Concord	NC	Lake Norman
Marchese	Harrison	Concord	NC	Lake Norman
Mityakov	Sergey	Clemson	SC	Upstate
Perea	Maurice	Gray Court	SC	Upstate
Perea	Karen	Simpsonville	SC	Upstate
Portnykh	Margarita	Goleta	CA	NONE





New Members ... willkommen



December New Members

LAST NAME	FIRST NAME	City	State	PCA Carolina's Area
Adams	John	Durham	NC	Triangle
Antol	Kevin	Waxhaw	NC	Metrolina
Cordes	John	Chapel Hill	NC	Triangle
DeKold	Patrick	Simpsonville	SC	Upstate
Evans	Matthew	Statesville	NC	Hickory
Fleming	Kenneth	Kernersville	NC	Triad
Groppe	Curtis	Moorestville	NC	Lake Norman
Groppe	Zachary	Moorestville	NC	Lake Norman
Hackenbracht	Greg	Cornelius	NC	Lake Norman
Hall	David	Charlotte	NC	Metrolina
Herrmann	Joel	High Point	NC	Triad
Hipp	John	Rock Hill	SC	Sandhills
Johnson	Clint	Jefferson	NC	Hickory
Kampen	Roy	Greensboro	NC	Triad
Lyons	Tim	Thomasville	NC	Triad
Munday	Jeff	Conover	NC	Hickory
Ray	Robert	Cornelius	NC	Lake Norman
Reynolds	Stephen	Charlotte	NC	Metrolina
Ricks	Tom	Charlotte	NC	Metrolina
Robinson	Aaron	Pittsboro	NC	Triangle
Schreiber	Douglas	Pinehurst	NC	Sandhills
Styles	Nathan	Greensboro	NC	Triad
Welchman	Dylan	Charlotte	NC	Metrolina

Tobacco Roads is the official publication of the Carolinas Region, Porsche Club of America.

Editor

David Harris

3201 Plantation Road

Charlotte, NC 28270

editor@carolinas-pca.com

The ideas, opinions, and suggestions expressed in *Tobacco Roads* are those of the authors and no authentication is implied by the editors or publishers. *Tobacco Roads* has not authenticated the claims and guarantees as offered in this publication.

Keeping It Current:

Have you bought or sold your Porsche? Moved or otherwise had a change of address or contact information? Those updates are handled at the national level of Porsche Club of America and can be updated either on the website, www.pca.org or by writing to:

PCA National Headquarters

P.O. Box 6400

Columbia, MD 21045

(410)381.0911 (p)

(410)381.0924 (f)

and email: admin@pca.org



It's not just the cars,
It's the people.
Porsche Club of America



2021 Event Calendar

For information about events outside the Carolinas Region go to:

<http://www.pca.org/Calendar/PCACalendar.aspx>

Want to see photos of recent Carolinas Region events?

Go to:

carolinasregionporscheclub.shutterfly.com/

If you want to contribute your own photos send an email to Ron Reed, Regional Media Coordinator, at

media@carolinas-pca.com

NEW PROCESS RELATED TO SUBMISSION OF CLASSIFIED ADS

Guidelines for Carolinas Region Classified Ad Submissions

1) All ads should be submitted to David Harris, Editor, at:

editor@carolinas-pca.com

3201 Plantation Road

Charlotte, NC 28270

Cell: (336) 577-6838

2) All ads will be posted to both Tobacco Roads and to the Regional Website unless otherwise directed. Submissions received by the 23rd of the month will be posted in the following edition. Web and print classifieds work on the same monthly cycle.

3) You must provide your current PCA membership number when submitting a classified ad.

4) No posting of ads for friends. Immediate family is ok.

5) No commercial ads. All commercial ads must be purchased. Contact TR Editor for pricing.

6) Ads will run for two months. If the item is not sold within that time frame the seller will need to contact the Editor at

editor@carolinas-pca.com and request an extension. Each extension will be for one additional month.

7) All pictures submitted should be in .JPG format and no larger than 800x600. One picture per submission.

8) Pictures will run on the website only.

9) All ads will be subject to editing for consistency and length.

10) Ads should include:

a. An accurate description of the item or items (including VIN preferably if applicable).

b. Price (Ads will not be accepted without pricing).

c. Where you and the item are located.

d. Contact information including name, phone number, and/or email address.

Below is a sample of the format we will utilize:

1964 356 Coupe: VIN 12323456. Champagne Yellow w/ Black interior. 150,100 miles. Very good condition. Paint bubbles on lower door skins. 12 volt conversion. \$42,995 firm. Contact Bob Smith, Hickory NC. bsmith@hotmail.com or (704) 555-1212.

WE BUY PORSCHE!!



Visit our Showroom located in Cornelius just off Interstate 77 at Exit 25

1837 Northline Dr Ste D - Cornelius, NC 28031

Call John Cleveland @ 704-907-5887 | porsche@ppi911.com

ADVERTISING:

To Advertise in Tobacco Roads contact the Advertising Coordinator at:

advertising@carolinas-pca.com

Ads are available from Business Card size to Full Page



Carolinas Region Officers and Board Members



Executive Council

President
 Jerry Widner
president@carolinas-pca.com
 704.657.7802

Vice President
 Jim Hess
vicepresident@carolinas-pca.com

Treasurer
 Sadie Kilcrease
treasurer@carolinas-pca.com

Secretary
 Giselle Burner
secretary@carolinas-pca.com

Past President
 Sadie Kilcrease
pastpresident@carolinas-pca.com

Area Directors

Hickory
 Director
 Michael Vittorio
hickory-ad@carolinas-pca.com
 (704) 258-3772

Metrolina
 Director
 Doug Strait
metrolina-ad@carolinas-pca.com

Sandhills
 Marty Barrett
sandhills-ad@carolinas-pca.com

Standing Committee Chairs

Membership
 Chair
 Re Racer
membership@carolinas-pca.com
 (704) 502-9533

Goodie Store
 Chair
 Kathy Boehm
goodiestore@carolinas-pca.com
 336-566-7501

Newsletter
 Chair
 David Harris
editor@carolinas-pca.com

Chief Driving Instructor
 Shane Tisdale
chiefinstructor@carolinas-pca.com

Club Race
 Chair
 Bill Scarbrough
clubrace@carolinas-pca.com
 803-600-6704

Autocross
 Chair
 David Harrison
autocross@carolinas-pca.com

Events
 Chair
 Charlie Massler
events@carolinas-pca.com
 (336) 970-7524

Web Management
 Chair
 David Violet
web-management@carolinas-pca.com
 (828)-289-2006

Driver Education
 Chair
 Steve Barrier
driversed@carolinas-pca.com

Regional Support Team

Triad
 Jerry Kilcrease
triad-ad@carolinas-pca.com
 (336) 847-9292

Advertising Coordinator
 Currently Vacant
advertising@carolinas-pca.com

Regional Historian/Archivist
 Conrad Carter
historian@carolinas-pca.com

Social Media Coordinator
 Marvin Waters
communications@carolinas-pca.com

Upstate SC
 Jeff Price
upstate-ad@carolinas-pca.com

Are you a Facebook member?
 The Carolinas Region has a group on Facebook. Search on 'Carolinas Region - Porsche Club of America'.

Safety
 Chair
 Shane Tisdale
safetychair@carolinas-pca.com

Triangle
 Richard Lutz
triangle-ad@carolinas-pca.com

Concours
 Coordinator
 Mike Jones
concours@carolinas-pca.com
 (704) 467-5042

Photography
 Coordinator
 Ron Reed
media@carolinas-pca.com

Lake Norman
 Christian Roedlich
christianroedlich@hotmail.com
 704-787-5141

February is for Love: We love the Boxster, and we love winning a 2021 Targa 4S. Photos by Brett Widner, and Rob & Debbie M.

Cover by DH





The #1 Porsche WorkShop in the Triad

336-993-5506

TXT 336-383-1642



We service these. So...We service them all.

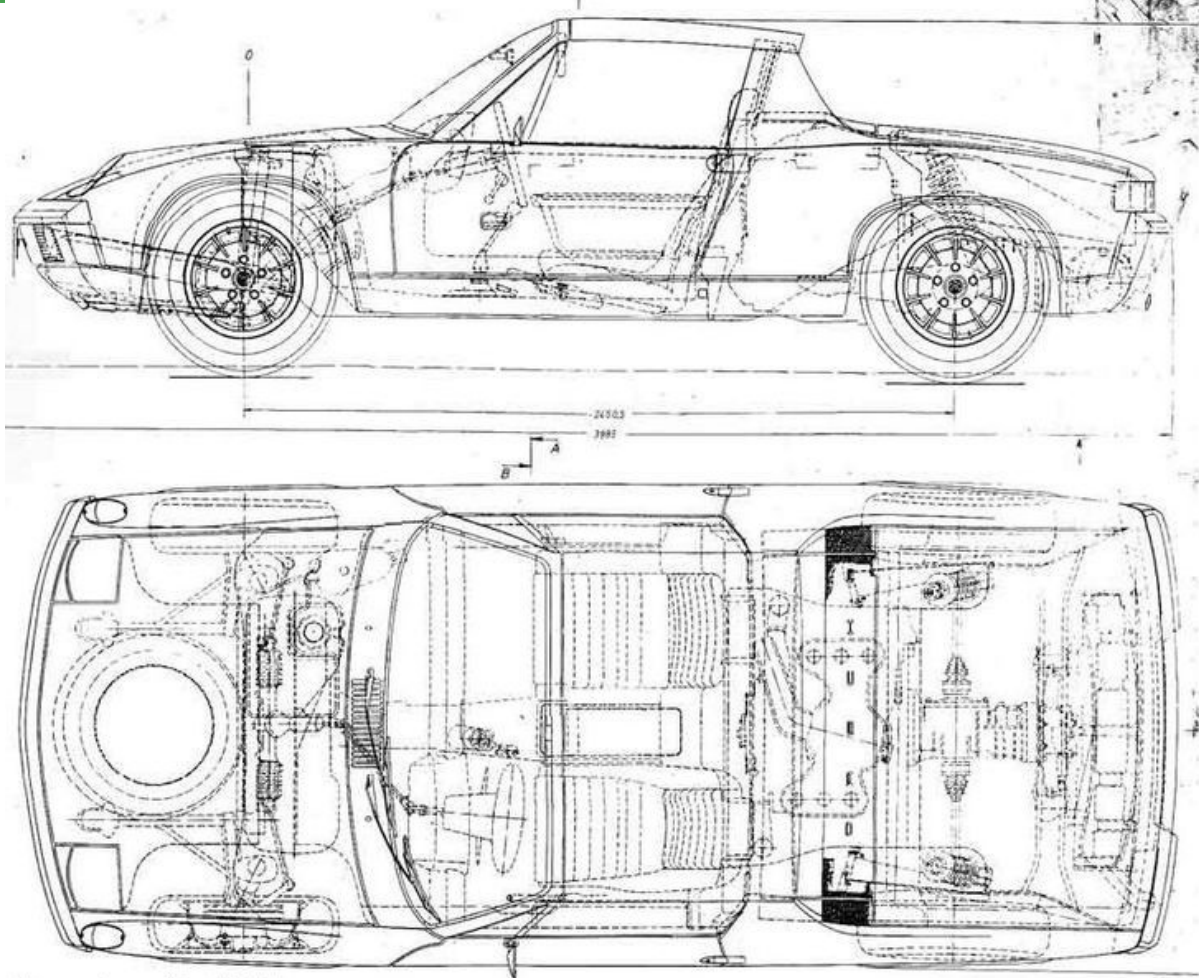

Area Updates:

February, 2021 (check website for event updates)

Triad Area By Jerry Kilcrease



Meeting: Third Tuesday of the month at 7:00 PM
Location To Be Determined. See Web and TR
Contact Jerry Kilcrease, Area Director
triad-ad@carolinas-pca.com (336) 847-9292

Hi Folks: I hope that everyone is doing well and that all of you are as anxious as I am to get active again with Triad Area PCA monthly meetings and events. As we move into 2021 we are all hopeful that our health officials will move closer to getting the COVID 19 virus under control so we can start getting back to some form of normal. While I do not have a clue when that will be, I am optimistic that it will be soon. In the meantime, I do have some good news related to a couple of upcoming events that should be of interest to many of you. "Super Car Saturday" is being hosted by Porsche Greensboro on March 20th; and the second event "Drive to VIR; Touring Laps & Lunch" will be hosted by the Triad Area PCA on May 22nd. Registration Fee is \$30.



"SUPER CAR SATURDAY" is hosted by Porsche Greensboro and they have invited PCA members and guests, along with members of the Ferrari Club and others, to join them at their facility located at 5603 Roanne Way in Greensboro for a Cars and Coffee Event beginning at 8am-10am. (To help you remember C&C events take a look at the above photo taken in 2016 at Reynolda Village). Then as part of Porsche Greensboro's

2021 "Roads and Vines Series" those interested are invited to join a drive up to visit the Divine Llama Vineyards and Farm located in East Bend, NC. All COVID 19 guidelines and restrictions will be followed. All attendees will be required to wear face masks and maintain social distancing at all times. For questions please contact Steve Sudler at ssudler@foreigncarsitalia.com



DRIVE TO VIR; TOURING LAPS & LUNCH - SATURDAY, MAY 22, 2021 - Please make plans to join us as the Triad Area PCA is hosting the

"Drive to VIR; Touring Laps, and Lunch" Event on Saturday, May 22, 2021. Dixon Johnston, Event Chair, has planned another opportunity to visit the premier Virginia International Raceway (VIR)

Laps, for touring Lunch... and afterwards, as a bonus, attendees can watch the MotoAmerica Superbike Races being held on the North Course (no charge). PCA Driving Tour Standards & State, local and PCA COVID 19 guidelines and restrictions will be followed. Registration fee is \$30 and all participants must register on www.clubregistration.net. Registration will for this event will open March 1st, 2021. Any questions please contact Dixon Johnston at Dixon.

Johnston@gmail.com. Or telephone at 838-308-2888.

2021 TRIAD AREA MEETINGS AND EVENTS:

The Triad Area will attempt to host a monthly meeting in either the April/May time frame, depending on the status of the COVID 19 situation. By then the weather should be warmer and members and guests will more than likely prefer either an outside location or as a minimum, an opened air venue with ample room to social distance. One thing for sure, whenever we do host our first 2021 monthly meeting, it will be a special "membership appreciation gathering" and will include quite a few significant door prizes and other surprises. So keep watching for the announcement. Please feel free to contact me anytime with any questions or comments at jkilcrease@triad.rr.com.

Sandhills Area By Marty Barrett



Meeting: Fourth Tues. of the month at 6:30 PM
Rotating Location - See report below
Contact Marty Barrett, Area Director
Sandhills-ad@carolinas-pca.com

January is the month for reflecting and planning. Let's dispense with reflecting, except to be thankful for not being more severely impacted by the Wuhan Flu. Planning for 2021 events is in full swing! Board members are working on Region events, highlighted by Carolinas Region 60th anniversary party in September. Thanks to our new president, Jerry Widner, treasurer, Sadie Kilcrease, and other board members for all the hard work.



Sandhills Area members are planning four driving tours, tech sessions and the Sandhills Motoring Festival over Memorial Day weekend. So far 93 cars are registered for SMF's twelve concours classes, a fun rally on Saturday, and two dinners. Check the web site for details and registration: Sandhillsmotoringfestival.com.

Our last dinner meeting was in early December. The January 26th dinner meeting was cancelled due to Covid concerns...replaced by a backroads drive. February 23 is the next scheduled dinner meeting. Cars & Coffee events in December and January were well attended...Motoring Festival C&C is 1st Sunday in Village of Pinehurst, and 3rd Saturday C&C is normally at Pine Scones in Southern Pines.



See Ya'll in Vaccine Line!

Marty



Lake Norman Area by Christian Roedlich



Monthly Meeting: Second Thurs. of the month at 6:30
Location: The Peninsula Yacht Club (Cornelius)
Contact: Christian Roedlich Area Director
christianroedlich@hotmail.com

Metrolina Area by Doug Strait



Monthly Meeting: Third Wednesday of the month
at 6:30 PM at Cafe Monte
Contact Doug Strait Area Director
metrolina-ad@carolinas-pca.com

As we are progressing into 2021, we sure hope to be able to return to some form of normalcy very soon. Due to scheduling conflicts at our usual meeting place, PYC, we skipped the January meeting. However, we are planning to hold our next PCA meeting as usual at the Peninsula Yacht Club, on Thursday, February 11th, 2020 at 5:00 pm, 18501 Harbor Light Blvd., Cornelius, phone 704-892-9858. As previously, we will meet in the Porsche Corral for food and refreshments. We are planning to meet earlier during the winter months to provide us with an opportunity to look at our beautiful rides in daylight.

As our new PCA Carolinas President, Jerry Widner, mentioned in his inaugural "From the Driver's Seat" piece in this newsletter, we are planning to run feature stories on any member's interesting Porsche project in the region. As Jerry pointed out, please contact me if you live in the LKN area and have or are working on a great Porsche project which you would like to share with the PCA Carolinas community.



The "Project" car at GMP

Well, my "project" originally was intended to be just simple yearly maintenance at GMP. However, I decided in the fall to finally do the IMS upgrade on my first gen 997 (I guess I heard and read one too many horror stories...). I dropped off my Porsche at the new GMP facility in Mooresville as it is a much more convenient location for me. And here starts the "project" part: after the GMP tech began with the IMS upgrade, he quickly determined that the clutch and flywheel had reached the end of their useful lives, which was a little surprising as I had replaced the clutch already once. As it turned out, the clutch slave cylinder (a relatively inexpensive part) was failing and caused the aforementioned damage – sort of along the lines of an IMS bearing that fails (just not as dramatic). Of course, my "project" was not quite finished yet as the thorough GMP tech determined that there was a crack in one of my aftermarket Fabspeed headers that he subsequently welded. I am happy to report that my "project" was successfully completed as determined by a fun ride home after I picked up my red beauty! Thank you for a job well done GMP!

Please stay safe and healthy! See you all soon again.

-Christian

HAPPY VALENTINES DAY PORSCHE LOVERS!!!

I hope you are all doing well and staying safe and healthy. With Valentine's Day just ahead, and considering the nice weather we have been enjoying, it's a great time to show your favorite Porsche some love, and do some pre-Spring cleaning, prepping & tuning for a nice drive to the country or highlands, to enjoy the arrival of spring flowers and visit some scenic parks.

I was able to join a few friends for nice afternoon drive thru the Uwharrie National Forest and surrounding areas recently, and what a great day we had. The roads are great, traffic is very light, and the scenery and views were fantastic. See the map below for the route we took. It's a great drive to do on your own or call a few friends and make a day of it. I will plan a club drive in the near future to do this trip. Stay Tuned!



As you all know, the "VID" continues to put restrictions on social gatherings, and group activities, but I'm looking for a nice outdoor spot, maybe a park to have a Saturday get together and light meeting, picnic style. Stay tuned!

FUTURE PLANS STILL UP IN THE AIR!!!

I will continue to monitor the state and local Covid guidelines for opportunities to get back together and meet as group for our dinner meetings and driving events, and get things rescheduled.

Any suggestions for things you want to do in 2021, let me know, Thanks!

STAY SANE, STAY HEALTHY, STAY SAFE!!!

Get out and Drive, Drive, Drive... Porsche style!!!

Sincerely, -Doug Strait-Metrolina Area Director



Hickory Area By Michael Vittorria



Meeting: Second Tuesday each month at 6:30 PM
Refer to Monthly Area Report for Location/Detail
Contact Michael Vittorria, Area Director
hickory-ad@carolinas-pca.com

Ahhh ... 2021 at last. And with the new year comes hope for a brighter future ... less political turmoil ... an end - or at least a significant diminishment - to the threat of COVID ... a return to something that most of us might identify as more "normal". Despite these promises, the new year is very young and we have a long way to go. So, for now, we continue to adapt and move forward.

Meeting Summary

After a "meeting-less" December, we decided it was time to "see" some of our Porsche friends again. So ... we set up a ZOOM meeting on Tuesday, January 12 and invited interested Members to grab a snack and adult beverage and join us.

Unfortunately, due to technical difficulties, some who wanted to were unable to participate. Nonetheless, 18 Members signed on for an opportunity to visit with one another and to catch up a bit on recent happenings. We also discussed the current state of affairs as it relates to COVID and its impact on future meetings and events. Within this context, we took the opportunity to outline some of our thinking and plans for the coming few months. Please see below. Though subject to change, at least we have a plan. So ... be sure to put these on your calendar.

Thanks to Jane's ingenuity, we were able to once again gift "door prizes" to lucky participants. This time, Joel Miller won a Porsche labeled wine opener and stopper. Nadia Scopes (in absentia) won a beer mug with the Porsche crest etched into the glass. Thanks to the continued generosity of Tim Scopes, we were also able to raffle a very special bottle of wine - Shift Red from the "racing series" of wines produced by Kevin Buckner's Adobe Road Winery. In addition to being an excellent red wine, the bottle sports a cutting-edge metal label that resembles a vintage, gated shifter and the cork is topped with a five-speed shift knob. Gail Iddings was the lucky recipient of this prize. Thanks, Tim for your continued support!



Next Meeting:

Tuesday, Feb 9 @ 6:30 - ZOOM meeting with a tribute to Valentine's Day. Grab a snack and your favorite adult beverage and join us for an opportunity to see (literally) and catch up with some of your Porsche friends. More great door prizes. "Sign-on" details to follow.

Coming Up:

With the reality of COVID still upon us, we have decided to adapt our meeting schedule/venues accordingly. Through at least June, we will continue to meet in a covered outdoor shelter that affords ample opportunity for social distancing. We will move our traditional Tuesday evening meetings to mid-day Saturday so as to take full advantage of the warmer outside temperatures. We will also pair meetings with a drive. Though subject to change, our spring schedule follows. Please put these dates on your calendar and plan to join us. Details to be announced prior to each meeting.

Saturday, Mar 20 Membership Meeting (outdoor shelter; one table per couple) followed by drive; bring your own lunch

Saturday, Apr 17 Membership Meeting (outdoor shelter; one table per couple) followed by drive; catered lunch

Apr 12-15 Spring Tour to Roanoke. Organized/led by Bryson/Kathy Kiser. Limited participation. Details and registration available on Club Registration

Saturday, May 8 Membership Meeting (outdoor shelter; one table per couple) light breakfast served) followed by drive to Hot Springs, NC, with lunch en route

Saturday, Jun 12 Gimmick Rally fund raiser for charity

Saturday, Oct 16 Poker Run fund raiser for charity

Nov 5-7 Fall Tour at The Ridges

Be safe ... stay well.

Triangle Area By Richard Lutz



Monthly Meeting: Fourth Thursday of Month
Nantucket Grill
5925 Farmington Rd Durham NC

Hello Carolinians, Triangle Area like many of us has not had many events to report. We've been able to continue with our cars and coffee events that have been well attended. The events have averaged approximately 15 cars at each.

Unfortunately it is with mixed feelings I must report this will be my last Area Update. I have accepted a position at East Tennessee State University and will be moving to Johnson City TN. In the short time I have been in NC I have met some excellent people and nearly all of them have been PCA members. Tennessee will be our third state and I'm sure we will meet some great people through PCA. I will always cherish our NC friends and hope to stay in contact at the track or other events. A new Area Director will be announced in the near future and I'm sure the Triangle Area will flourish as 2021 moves forward.



Upstate Area By Jeff Price



Meeting: Second Tues. of the month at 6:30 PM
Quaker Steak & Lube
10 Chrome Drive Greenville SC
Contact Jeff Price, Area Director
upstate-ad@carolinas-pca.com

The Upstate Area has been holding our Area Meeting outdoors for most of last year, yet with the colder evening weather and early sunset, it made an evening outdoor meeting less inviting. Input from area members suggested having a Saturday afternoon meeting to take advantage of warmer daytime temperatures and sun light. So, on Saturday, January 23rd we held an Area Meeting at Quaker Steak & Lube, 10 Chrome Drive, Greenville.

The suggestion of a Saturday meeting was very well received as we had a robust turnout of 26 cars and around 37 members. The weather was fantastic and it was a great spending some time outdoors.



Our 50/50 Charity Raffle included prizes of a \$50 gift Certificate to Griot's Garage and a \$25 Gift Card to Quaker Steak & Lube, in addition to 50% of the "Pot". The winner of 50% of the pot, Ed M.,

showed Porsche Level Charity and donated his \$75 winnings back to our Charity. Thus, we raised \$150 for our charity at this meeting. Many thanks to Dennis K. for selling the raffle tickets! This is always a huge help – Thanks Dennis.

Drivers Education – John B. gave an update on the Regions Drivers Ed program for 2021. The Drivers Ed team is working out the details to enable in-car instructor, yet this is all dependent on the COVID situation. You can sign-up for the Drivers Ed events at Clubregistration.net. It was also noted that the Carolina Motorsports Park (CMP) track has been repaved and is in great condition.

"Love Run" TSD Rally – Our Driving Tour Coordinator, Robert R. gave an update on our planned "Love Run" Time Speed Distance (TSD) Rally scheduled for Sunday February 14th – Valentine's Day! On a TSD Rally, you will need a navigator, so this will be a test of your love. The two of you trapped in a Porsche navigating a route through the upstate while recording your time, speed and distance. The closest to the reference time and distance will be declared the winner! Porsche of Greenville has provided a \$250 gift certificate for our top prize, and I am working on some other goodies for 2nd & 3rd places.

We will have a zoom driver's meeting the Friday evening prior to the run where you can ask questions and learn about the mechanics of these drives. We will meet on Sunday and send off cars on the route every 5 minutes. So, if you happen to run into a Porsche - one of you is probably way off. There will be check points along the route for you all to take a break. If you are interested please contact Robert at (drwhosc@gmail.com). Sign up for this event is on Eventbrite (link below). This is a must so Robert can communicate with you.

<https://www.eventbrite.com/e/upstate-pca-love-run-tickets-136361808841>

"Build Your Porsche" Raffle – To give us some fun Porsche stuff

to do during the winter months, I have been working with Jared Chernick, Porsche Brand Manager at Porsche of Greenville on a "Build Your Porsche" contest. The contest is now open and details have been emailed to all Upstate Area members, and summarized below;

Porsche of Greenville and the PCA Carolinas Region - Upstate Area is offering our PCA members a raffle chance for a Porsche Experience Center (Atlanta) Driving Experience.

In order to enter the Raffle, you simply need to go online to the Porsche USA Website and use the "Build Your Porsche" Configurator to create the Porsche Vehicle that you would like to buy if you were in the market for a new Porsche..... – not just every option, but ones you would actually be willing to pay for. You know, the "must have" options on your list, and your preference on body style, colors, wheel style, etc.

You choose the vehicle (911, Cayenne, Boxster, etc....) and the Model (Base, S, C4, Turbo, etc), along with all the other optional choices for that vehicle that are on your "must have" option list. Don't just load up the car, we want the options that you really must have and would be willing to pay for.

Once finished, submit the Porsche Build Code to Jared Chernick, sales manager at Porsche of Greenville at (jchernick@greenvilleautomotive.com) and myself (upstate-ad@carolinas-pca.com) along with your PCA Member Number for an entry to win a Porsche Experience Center (Atlanta) Driving Experience, valued up to \$500.00.

Each PCA Member may submit one entry. Each PCA Co-Member may submit one entry. All entries must be received by Sunday, February 28th, Midnight. The winner will be selected at random (by raffle) from all entries received. The name of the winning entry along with their Model & Configuration will be listed in our Upstate Area News Email & Tobacco Roads Newsletter. Winner will be announced prior to March 30th, 2021.

Porsche of Greenville - PCA Member Only Tire Special

I have been working with Dean Petersen, Service Director, from Porsche of Greenville on a few Super Service Specials for your Porsche, and the first we have put together is a Special Tire Deal for PCA Members only. I am sure the following is a great deal for new tires!

- Beat Tire Rack Price on any current production tire by 5%.
- Tires include a 2 Year Prorated Tire Hazard Warranty.
- Mount & Road Force Balance @ \$30 each. That's only \$120 for a set of 4!
- 4 Wheel Alignment for only \$229. That 15% off their normal cost!

This PCA Member Only Tire Special will be good through March 31st, 2021. So, if you need new tires for this coming spring, now is the time to get them. Just call Steve Saunders, Porsche Service Advisor @ (864) 478-1444 and ask for their PCA Member Tire Special.

Many thanks to all for your input and words of gratitude. This is your club and your input on what you would like is essential. Thank you!

Drive Safe, –Jeff Price



Drivers Ed - Steve Barrier

I hope this publication of Tobacco Roads finds you well and in good spirits! Before I get into information for our activities this year, I'd like to give another big Thank You!! to our two sponsors who stepped up during 2020. HBi Auto and Porsche of Hickory have both been very good friends of Carolinas Region and we thank them for their support. This year will see a few changes in the program, so let's discuss some of those ideas, and you are welcome to send me feedback if you would be interested in taking advantage of them.

First, we are bringing in car instruction back to the program, with an emphasis on personal safety before and after in car encounters. Our March 13-14 event opened registration January 25th and will be held at Carolinas Motorsports Park in Kershaw, SC. If you have never been to a HPDE event, this is a great track on which to learn. For our track seasoned members, if you didn't come in September of last year and remember the old tire-eating pavement, be aware it was repaved last summer and the reviews of the new pavement are extremely positive.

In order to ensure we are able to deliver instruction for all students, we will be putting all drivers for our Green and Blue instructed groups into pending status until we can guarantee there will be an instructor available. We will be delivering instruction through single instructor/student pairings and retaining a reserve of instructors for the event to cover anyone falling ill leading up to the event. Please be patient with our student registration process and we will work diligently to confirm as many students as we can safely accommodate.

The second change is an addition to the program in the form of organizing a teen driving event in conjunction with Tire Rack Street Survival. If you haven't heard about this program and have new drivers or soon to be new drivers in your family, I highly recommend checking it out. Held in a low speed environment, this program helps teach teens car control, what to do when things go wrong, and what those events feel like behind the wheel. One on one coaching and a well developed process have made this program a huge success. At this time, we are unsure of the timing as much of it will depend on the status of our not so friendly corona virus. Tire Rack suspended all events in 2020, and we are working to bring this program into our list of events. More information can be found on the general program at <http://streetsurvival.org> and we will update you as events are planned in more detail.

Another change is the inclusion of a vintage group for those with classic Porsches (and other marques) who find the constant hand out the window tiring with more modern Porsches in the same group. This group will be solo only and comprised of cars older than 1989. Entry to this group is voluntary, so make sure you request it from our registrars!

We are pondering more additions, so stay tuned to future installments of Tobacco Roads for information about what is going on. As you think through your track season, be aware that SA/SAH2010

helmets will not be accepted starting this year. We understand there are manufacturers who have not released their 2020 helmets yet, but our policy from a safety and durability perspective is to retire them after 10 years of service. If you have a 2020 helmet on order and it is not arriving in time for March, send me an email and we can discuss our options. This practice aligns with safety procedures and recommendations from PCA National.



On a more practical note, now is the time to go through your car and perform all the minor maintenance tasks and touch ups that come along with owning and driving your car. Maybe it is that slight squeak coming from just to the left of your steering wheel, or perhaps you need to tighten the sun visor attachments. Never underestimate a car's ability to loosen items as it ages! It's also a good time to give your car the loving touch of an interior detailing. Get out the vacuum and your flashlight and go spelunking under your seats for the nitty gritty dust and dirt that inevitably collects there. Who knows what you might discover has been lost over the past year (or more). While you're at it, make plans to change the fluids, check the lug nuts, and clean the leaves and debris out of the screen under the windshield. Especially important in this area is making sure the drains aren't clogged. Make the appointment at the shop if you aren't the kind to dive under the car yourself. Preparation is the key to success, and regular maintenance will ensure maximum longevity.

Thank you for tuning in and reading this month's edition. I trust the winter is finding you well, that you are just as juiced about getting on track again as we are, and that we will see you in March!!



Now is the time to perform minor maintenance tasks and touch-ups.



President's Project Page

vier Generationen

This is the first installment of the Presidents Project Page; while this isn't necessarily a "project", I find it a fitting way to start off by honoring and showcasing our Members and their cars...hope you enjoy.

2021 marks more than just the end of 2020; it is the 25th Anniversary of the much beloved Porsche Boxster. If you've never driven one; you are doing yourself a serious disservice. With near perfect weight distribution and impeccable handling; either rowing through a manual gearbox or letting the PDK (or Tiptronic for pre '09 models) switch them...is a pure joy. Bonus feature! Put the top down and feel the wind rushing through the cabin, taking in all of the glorious sounds of the Flat 6 Symphony...simply wondrous! I do believe the word INTOXICATING has been used by Ann and I while on numerous 5+ hour drives through the Carolina country side in her 981 Boxster.

You can find all the technical statistics and data analytics in multiple places should you choose to do so. I want to get straight to focusing on the design, styling and how we "feel" when behind the wheel. When I asked four of our Carolinas Region Members to meet up on a Saturday afternoon for a "shoot-out"; camera style...I believe the answer was unanimous - "absolutely Yes, anything to get out for a drive!"

Dean Perella, General Manager of Porsche Southpoint (located in Durham), and his staff were very receptive to clearing out the front of the dealership despite a "busy sales" Saturday afternoon. The vier Generationen lineup of arguably "the car that saved Porsche" would choose to be a worthy cause. Four Silver Boxster S's with Black Interior...all "row your own boat" manual gearboxes looked simply brilliant in the filtered afternoon sun. You can see the transitional design cues that reach across all four generations; all simply stunning to look at.



L-R: Rory (986), John (987), Fred (981) and Rob (982)



L-R: Rob (982), Fred (981), John (987) and Rory (986)

The subtle differences between the 986 and 987 follow typical Porsche fashion - evolution over revolution. The complete redesign from the 987 to 981 models saw the reduction in weight, increase in power, longer and wider all while improving on an already "perfect" platform. We again see the subtlety of changes from the 981 to the newest version 982 (also now named 718 Boxster in honor of the flat 4 racecar from the 50's).

I had asked each of the owners to "tell their story of why the Boxster" ...and I see no better way to tell those stories, except in their own words.

RORY (986) - I bought my 2000 Boxster S in 2018 as my first entry into the Porsche family. I will venture to say that I may have gotten the best bang for the buck in the history of Porsche sales. It was a two owner car with 108k miles, a clean Carfax, and I paid \$7,500. I have never had a problem with it in the two and half years I have owned it. I think the seller immediately regretted selling it when the next month's Panorama featured the 986 as one of the best values in the Porsche line-up.

Believe it or not, I found the car on Craig-

Needless to say, owning this car has completely hooked me on the brand. I taught myself to heel-toe in it, my 3yr old son and 6yr old daughter help me wash it, and on the rare date night my wife loves having the top down. I have also enjoyed a little DIY work including installation of a K&N air filter which I am convinced has given me a little boost. As someone who grew up around Chevy muscle cars (my father owned various Corvettes and Camaros) it wasn't the obvious first choice for me but I won't be looking back. I hope to have an '87 911 parked next to it someday.



JOHN (987) - I've always been fascinated by automobiles, particularly ones with notable designs or engineering. I began collecting Matchbox and Hot Wheels cars as a little kid then moved on to building Legos cars. Finally I "graduated" to owning and learning to drive my own cars.

Years later in 2014, after extensive researching and then searching for the right one, I had the pleasure of acquiring my 2005 Boxster S. I've thoroughly enjoyed the time I've spent with this car. Whether driving it, listening to it, or simply looking at it; it never fails to bring a smile to my face. I'm amazed at how capable the Boxster is, while still being very easy to drive.



I've also enjoyed the community the Boxster creates. From other Porsche owners, to strangers who stop to talk about it, to finding excuses to enjoy the car with my family and friends, the Boxster seems to simply bring people together. I'm looking forward to being a part of the Porsche family for many years to come.

Fred (981) - We bought our Boxster S in 2015. But the story began long before. I developed a passion for sports car racing while growing up in the '60's and '70's and I remember sitting in class, sketching the supercar of our time, the Ford GT40. Soon, those sketches became 917s, in Gulf Livery. Inspired, I started racing enduro Karts in high school with my first race at VIR in 1972. Subsequent races would have 400 plus entrants, running the full course. On the major circuits of the day, the Porsches had an eerily quiet whoosh sound down the straight, with a slight pop as the cars shifted. I had the pleasure of seeing Peter Gregg drive the Brumos 911 at several races.

Then my passion hit the pause button, a common story of college, work, marriage, and children. But eventually, I dipped my toe back in the waters. For a while, Barbara, my wife, and I enjoyed a BMW M Roadster. It was an awesome car: tenacious handling, lots of low end grunt, but a little small. We started to rack up the miles, so we sold it before financial calamity.

After a few months without a sports car, Barbara said, taken me for a ride in the mountains this year." What's weekend 2015, we packed our bags, jumped in our GTI. One night in an Asheville hotel, she was getting ready to phone "somehow searched and found a Porsche dealer had a nearly new Silver Boxster S. I mentioned to Barbara get another sports car. She said we should go look at we called ahead and it was sitting out front when we ar-



"You know, you haven't a guy to do? So Labor Day and headed for the hills. go out for supper and my in town". Turns out they that eventually I wanted to the car. The next morning,

the windshield that was inscribed with my name! A brief drive seduced us, and soon, Barbara (yes!) was writing a check. Of course, she got to drive it home. But I got to follow behind, my eyes learning every line, every move of this new beauty. A curvy hip, with confident moves in the corners, and a voice that could sing!

Two weeks later we attended a track day hosted by the dealer at Roebing Road. Barbara and I alternated sessions, so the car got a good workout, and almost ran out of gas! We continue to be amazed at how competent this car is: comfortable, room for luggage, fast on the road and the track.

Our 981 now has about 16K miles. We've only tracked it that one time. It is mostly used for day or weekend trips to the mountains, or going out to eat. Now that I have more time on my hands, I hope to give it the exercise it deserves.

Rob (982) - I started out in 2016 looking for a Z4. During a trip to the BMW Performance Center I drove a Z4 M and found the Z4's as not tight track friendly. I started looking for alternatives, the Miata's for example have always been fun. Then my wife and I saw a Boxster in Atlanta, and I started researching them. In 2016-2017, I looked for a preowned 981 with manual and Sport Chrono, although I did not expect to find manuals in such short supply. We continued to save and in 2018, with my wife onboard, we started scouting the new 718 Boxster's. We took a few test drives with PDK and after driving several 981's and 718's we were hooked. Our focus moved to specifying my dream car within our budget. For 6 months, I used the configurator and internet to nail down every detail; Base or S, PTV or not, etc. We ordered our 718 Boxster S in April, allocation in Jun, and took delivery in late August 2018. The allocation forced us to a 2019 and a color change, to GT Silver.



I enjoy driving our Boxster to the grocery store, or to work. Anywhere is a great place to go in our Boxster and we always take the long way. The handling of the Boxster completely exceeds all of my expectations. My daughter and I took a 10hr run from North Carolina to Southern Pennsylvania all on back roads. We had a blast with the top down as well as up in rainstorms and made our stops at small stores periodically. It was a great drive and we could have gone longer.

Our Boxster is parked on 4 post lift when not in use. I see it entering the garage every day at eye level and always say "Good Morning" to her, even if she is not getting out.

Thanks to Rory, John, Fred and Rob for taking the time to meet us for a quick photo session as well as providing their story of "why the Boxster". As you can read, they have been "bitten by the Porsche Passion Bug".

We all owe the Boxster a level of gratitude for what it has meant to Porsche and its owners over the past 25 years. The newsstands, internet and video journals from the past quarter century are all full of Praise and Admiration of this amazing piece of engineering, design and function. Here's to another 25 years!!!

I'll be on the lookout for YOUR story, YOUR project, YOUR passion, and I look forward to travelling around our Carolinas Region to find it. We will put it here!

Until next month.....



**TRUST A FELLOW PCA MEMBER
TO INSURE YOUR HOME, CARS,
AND BUSINESS!**



**We will shop your insurance with multiple companies
for the best coverage and price.**

A team of 13 experienced agents to serve your insurance needs.

Personal and courteous service guaranteed.



**JASON HERMAN
INSURANCE**

www.jasonhermaninsurance.com

Conover: (828) 465-1350 | Newton: (828) 464-2743



THIS SEARCH ENGINE RUNS ON GASOLINE



Members of the Porsche Club of America receive up to a 5% discount on collector insurance with Hagerty

HAGERTY®

INSURANCE. DRIVERS CLUB. CAR VALUES. ENTERTAINMENT. THE SHOP. DRIVESHARE.

Drive with us. Spencer Gates | 704-612-1546 | jgates@hagerty.com

Vehicle make and model names and logos are property of their respective owners and their inclusion does not imply sponsorship of or affiliation with Hagerty or any of its products or services. Hagerty Insurance Agency, LLC, (HIA) determines final risk acceptance. Purchase of insurance through HIA is not required to receive optional products or services through Hagerty Drivers Club, The Shop and DriveShare. Hagerty, the Steering Wheel logo, HAGERTY FOR PEOPLE WHO LOVE CARS, THE SHOP ASSEMBLED BY HAGERTY, and DRIVESHARE BY HAGERTY are registered or common law trademarks of The Hagerty Group, LLC ©2020.



Goodie Store

Kathy Boehm • 336.566.7501 • KathyABoehm@gmail.com

Call or email your order

Soft Shell Jackets & Vests

Special order for PCA Members
Includes "PORSCHE" embroidery on left chest &
Carolinan Region embroidery on back yoke

Outerwear Comfort Zone				
WARRANTY 4 YEAR	WATER PROTECTION	WIND RESISTANT	WATER RESISTANT	WIND PROTECTION
✓	✓	✓	✓	✓

FREE shipping
for orders placed by
2/29/2021



VESTS Men's & Ladies
S-XL \$63, 2XL \$68, 3XL \$71, 4XL \$75

JACKETS Men's, Ladies & Youth
Youth-Adult XL \$65, 2XL \$70, 3XL \$73, 4XL \$77

Youth JACKETS & Adult VESTS

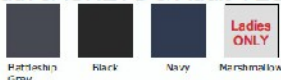

ADULT JACKETS



Porsches & Parts

Notice: Caveat Emptor. Neither the Carolinas Region-PCA nor the Editors (Carolinas Region) endorse, guarantee or have, in any way, screened, verified or attest to the veracity of the following ads. The Carolinas Region makes no warranties, express or implied, with regard to any advertised goods or services. Buyers should practice due diligence.

Additional information on all classified ads can be found by either contacting the seller or checking our website for photos at www.carolinas-pca.com.

Porsches

1972 911T. VIN 91112102421. Silver/Black. 72,400 – Original owner. Excellent condition. “S” trim, MFI. New clutch, tires, shocks, bushings in transmission linkage. \$120,000. Contact Ralph Timmerman, Travelers Rest, SC. Ralphwt911@gmail.com, or (864) 689-1024.

1990 944 S2 cabriolet black on black in black. 78,000miles. Very good condition \$20,000 FIRM new tires, I have the silver porsche cover. VERY GOOD CONDITION Must see to appreciate..a true driving machine. Contact Shirley Fly Winston Salem NC anfly@triad.rr.com (336) 794-0190.

2001 Boxster S: VIN WPOCB2981U662434 – Red with Black w/ Black leather interior. 30,600 miles (third owner). Excellent condition. IMS replacement 2018 – Coccoa Mats – Colgan Bra – Fitted Cover – 18” Turbo wheels with painted hubs– new Porsche Radio – New Khumo Ecsta 4X -- \$14,000, contact Jack Baringer, Clemson, SC, jack@baringer.com or (864-719-0711

Parts – Parts Cars – Projects

Spare set of 17” 986 Rims with Hancock Tires. Rims original and tires about 5 years old with a few “gentle” laps at CMS during HPDE. No longer running HPDE and cleaning garage. \$225.00. Contact Doug or Linda in Augusta (803) 443-9900

1986 944 Guards Red/Tan interior. Unknown mileage. I purchased this car about 5 years ago strictly for a parts car. Would prefer to sell the whole car for parts or a track car. \$600 OBO
Contact Linda Liberty, stphilipmusic@aol.com (352) 895-6399

Fabspeed GT3/GT3 RS Center Muffler Bypass with tips. Fits 997.2 VGC \$495 OBO + shipping.
Contact Garrett (864) 240-3316.

Non Porsche For Sale

1st CLASS SUSPENSION FOR A 1st CLASS SPORTS CAR

- Removal, service, and installation of your struts/dampers
- Vehicle setup, alignment, and preparation.
- Full service damper rebuilds with every set dyno tuned.

Email us today-
Wes@Burtonshocks.com



**We are here
for you!**



Why Buy from Porsche in Hickory & Greensboro

Award Winning Service

We offer award-winning Porsche service and repair, so you have access to the latest specialized technology and precise analysis from Porsche trained technicians.

We are keeping our service lanes and showrooms open and available to assist you with your automotive needs.



PORSCHE

Enhanced Sanitization

We are taking extra precautions in the cleanliness around our dealerships to protect our guest and teammates.

Contactless Shopping Experience

We can arrange off-site test drives, virtual showroom experiences with video as well as complete a full vehicle purchase through our online Porsche Digital Retail Sales Experience.

Complimentary Valet Service

Offering complimentary pick-up and delivery of your vehicle for service needs. Sanitizing services available.

Free Delivery on any Vehicle

Buy your next car online and we'll bring the car to you, if within 250 miles from the dealership.

A Dealership based on GR101

We always strive to treat others the way we would want to be treated and always endeavor to do what is right and fair.



Porsche Greensboro
I-40 at Guilford College Rd.
Exit 213
5603 Roanne Way
Greensboro, NC 27409
336-294-0200
PorscheGreensboro.com



Porsche Hickory
1207 South Center St.
Hickory, NC 28602
828-328-1050
PorscheHickory.com



Tobacco Roads
 David Harris, Editor
 Carolinas Region – PCA
 3201 Plantation Road
 Charlotte, NC 28270

PRSRT STD
 U.S. POSTAGE
 PAID
 PERMIT #34
 GREENSBORO, NC
 27405

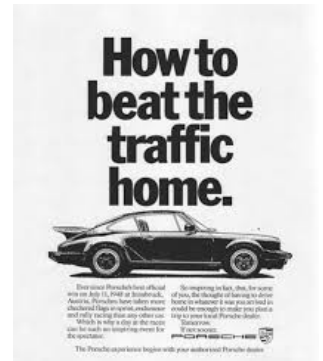
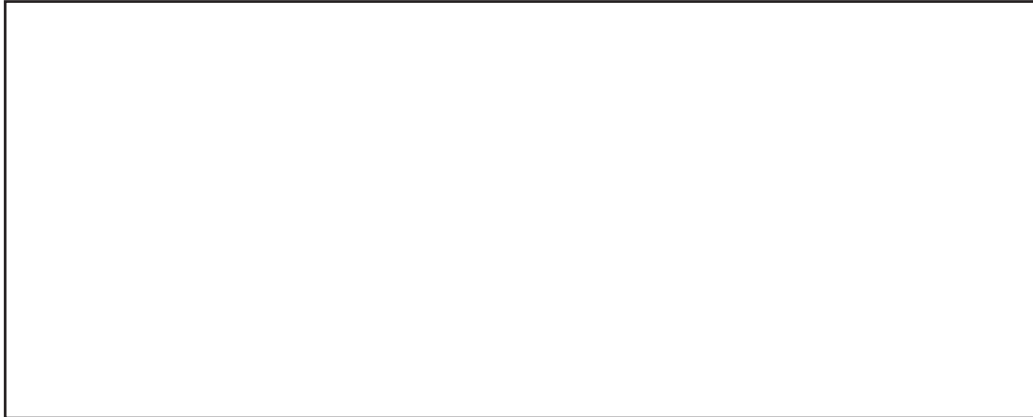

carolinas
 PORSCHE CLUB OF AMERICA **region**

WE WANT YOU!
To Write & Photo
For Tobacco Roads
 Contact
 editor@carolinas-pca.com

PORSCHE UPGRADES & SERVICE

Offering our support, no matter where your office may be.

- +Enclosed Transport
- +Trackside Services
- +Demo Loaner Cars
- +Pickup & Delivery

CHARLOTTE + LAKE NORMAN

GMP Performance - CLT
 710 Pressley Road
 Charlotte, NC 28217
 704-525-4946

GMP Performance - LKN
 292 Rolling Hill Rd
 Mooresville, NC 28117
 704-660-9920

GMP
 PERFORMANCE

Check us out on Social Media

