

# MOBILE SCIENCE CABINET

OVERALL SPECIFICATIONS



**National Public Seating**

## MATERIAL OVERVIEW



ALL WOOD PARTS (EXCLUDING DOORS AND TABLETOP):

- OAK VENEERED SURFACE
- PLYWOOD CORE
- BLACK EDGE BANDING



DOORS:

- OAK VENEERED SURFACE
- PARTICLEBOARD CORE
- BLACK EDGE BANDING



TABLETOP

- BLACK CHEMICAL RESISTANT HPL SURFACE (CHEM-RES)
- PARTICLEBOARD CORE
- BLACK PVC EDGE BANDING

# MSC01

MSC01	DIMENSIONS (in Inches)
A	36.27
B	27.99
C	48.03
D	29.06
E	42
F	21.26
G	9.13 - 19.21 (min-max)

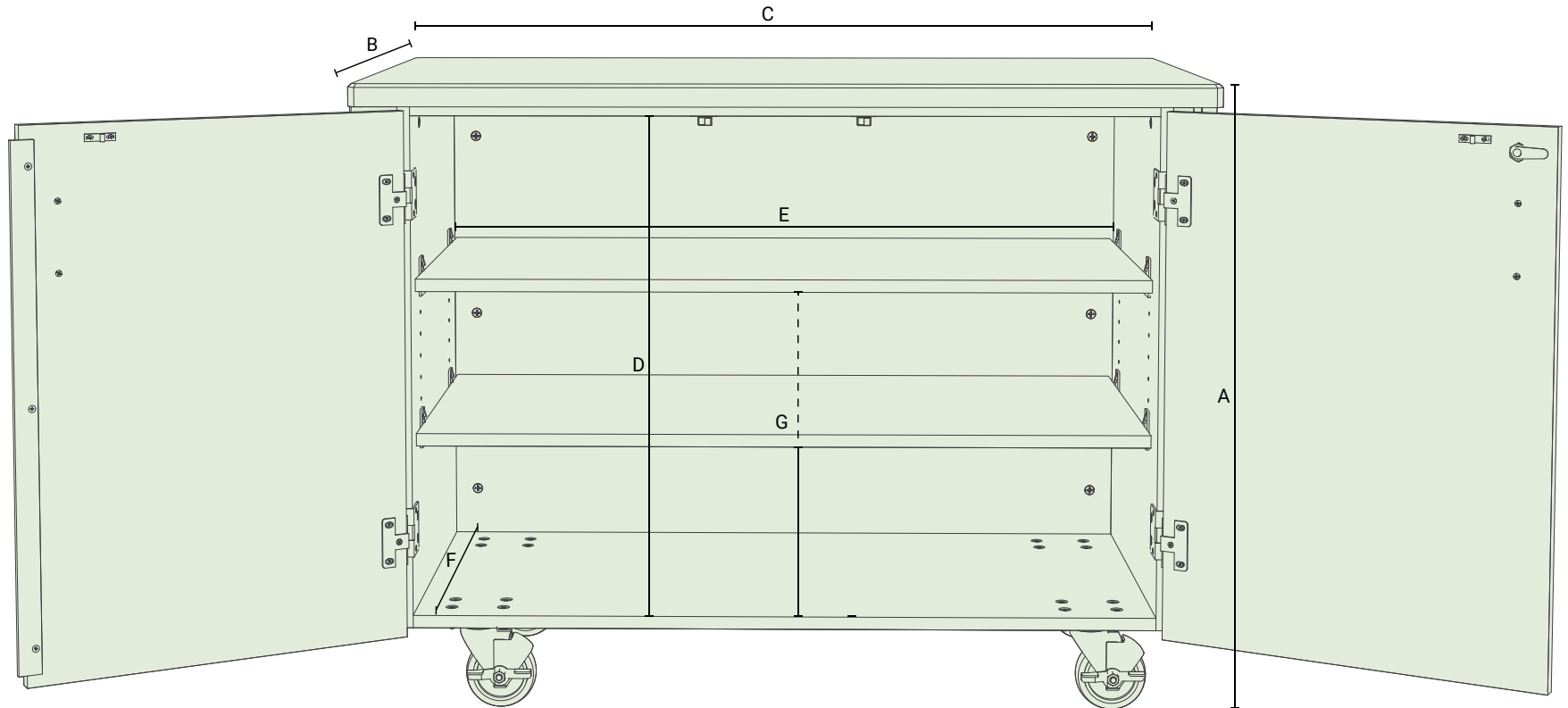

# MSC01SW

MSC01SW	DIMENSIONS (in Inches)
A	69.93
B	27.99
C	48.03
D	29.06
E	42
F	21.26
G	20.63
H	27.72
I	15.59
J	13.59
K	5.63
L	6.23-41.81(min-max)

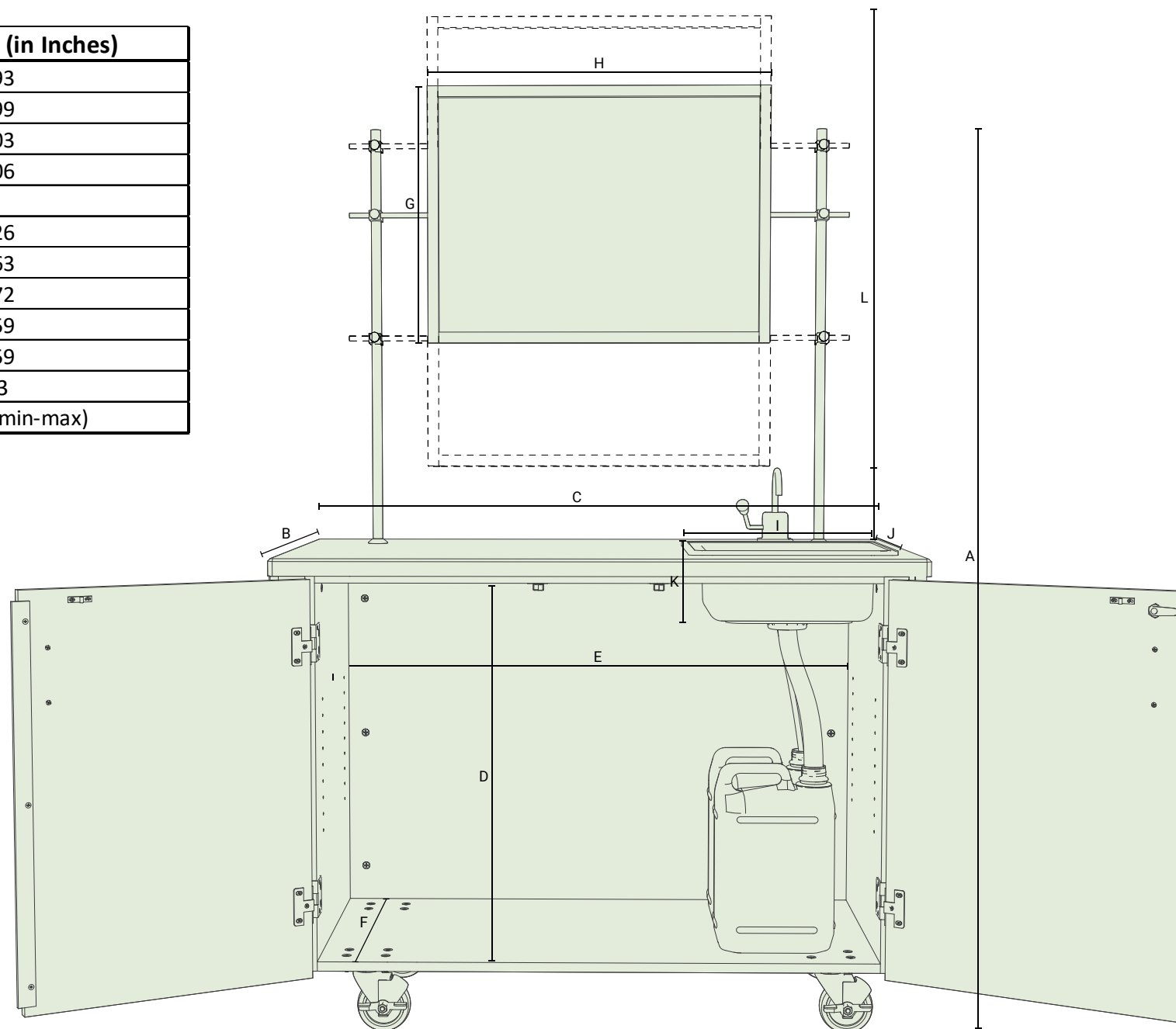

# MSC02

MSC02	DIMENSIONS (in Inches)
A	36.27
B	27.99
C	48.03
D	17.8
E	4.92
F	16.85
G	17.83
H	23.39
I	20.47
J	29.06
K	9.13 - 19.21 (min-max)
L	21.26

Drawer Weight Capacity	40 LBS
------------------------	--------

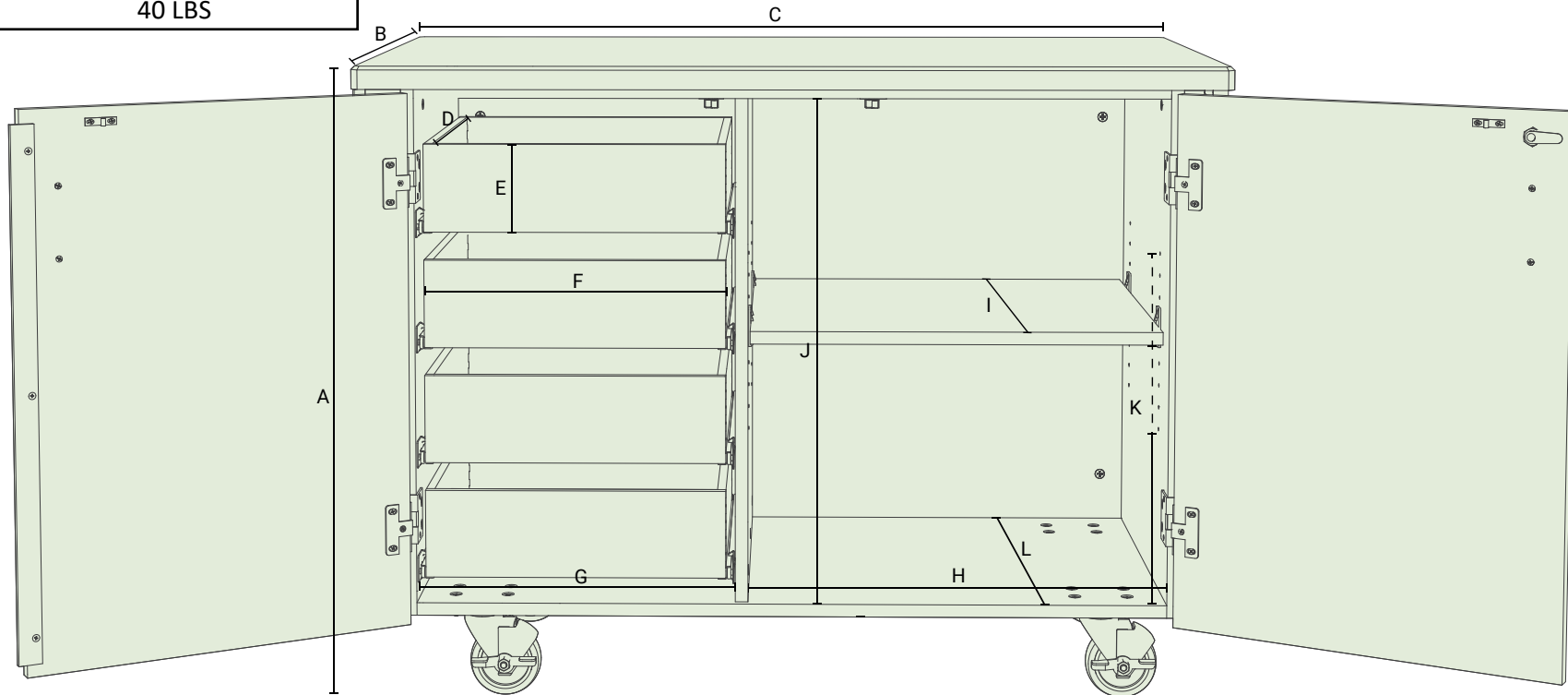

# MSC02SW

MSC02SW	DIMENSIONS (in Inches)
A	69.93
B	27.99
C	48.03
D	17.8
E	4.92
F	16.85
G	17.83
H	23.39
I	21.26
J	29.06
K	20.63
L	27.72
M	6.23-41.81(min-max)
N	15.53
O	13.59
P	5.63
Drawer Weight Capacity	40 LBS

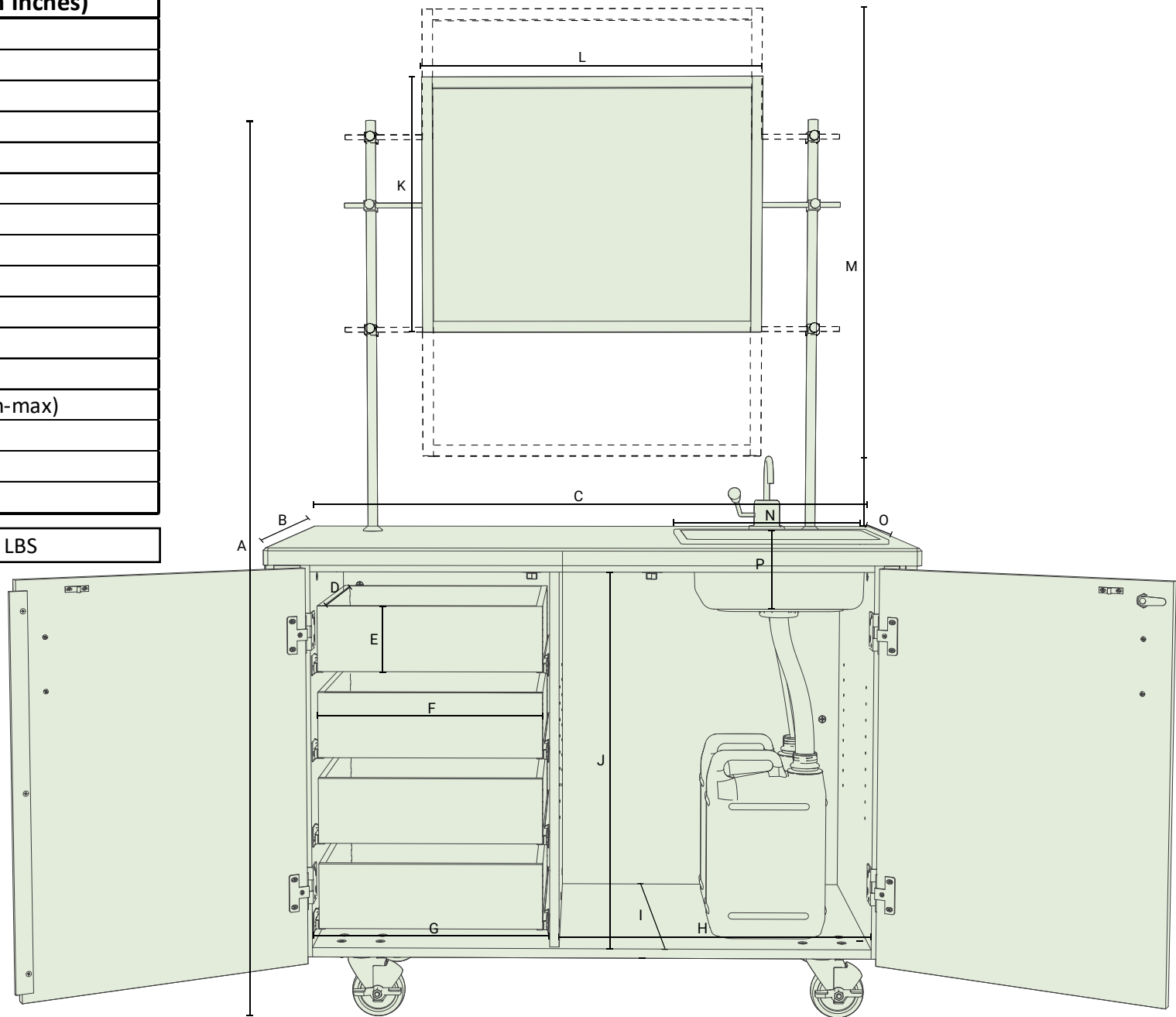

# MSC03

MSC03	DIMENSIONS (in Inches)
A	36.27
B	27.99
C	48.03
D	6.89
E	12.44
F	15.16
G	12.64
H	16.93
I	4.21
J	9.53
K	26.02
L	12.28
M	9.14
N	21.26
O	28.35
P	13.03
Q	9.13 - 19.21 (min-max)
Drawer Weight Capacity	40 LBS

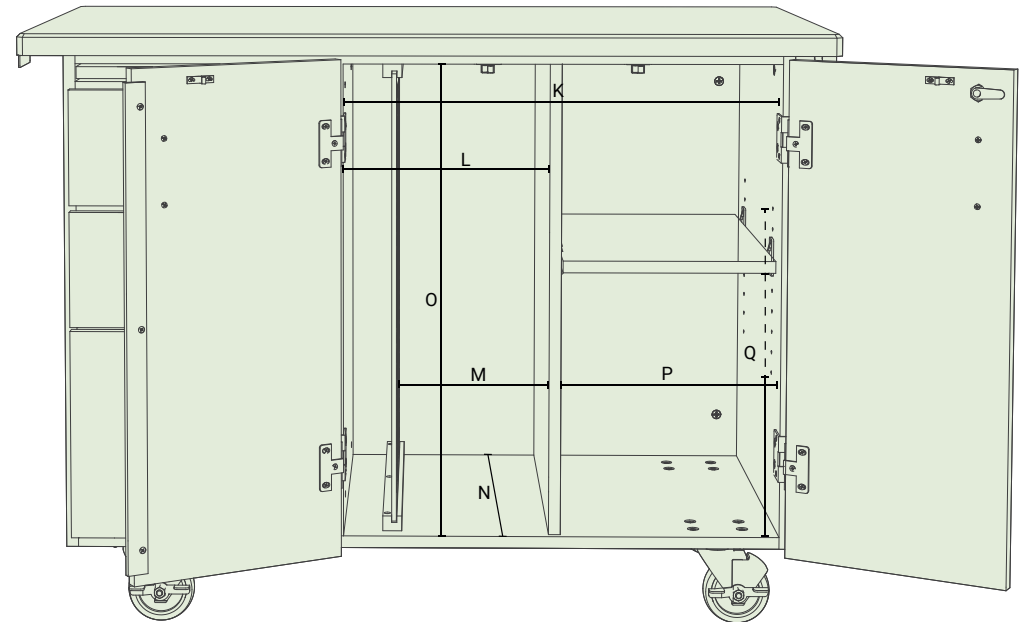
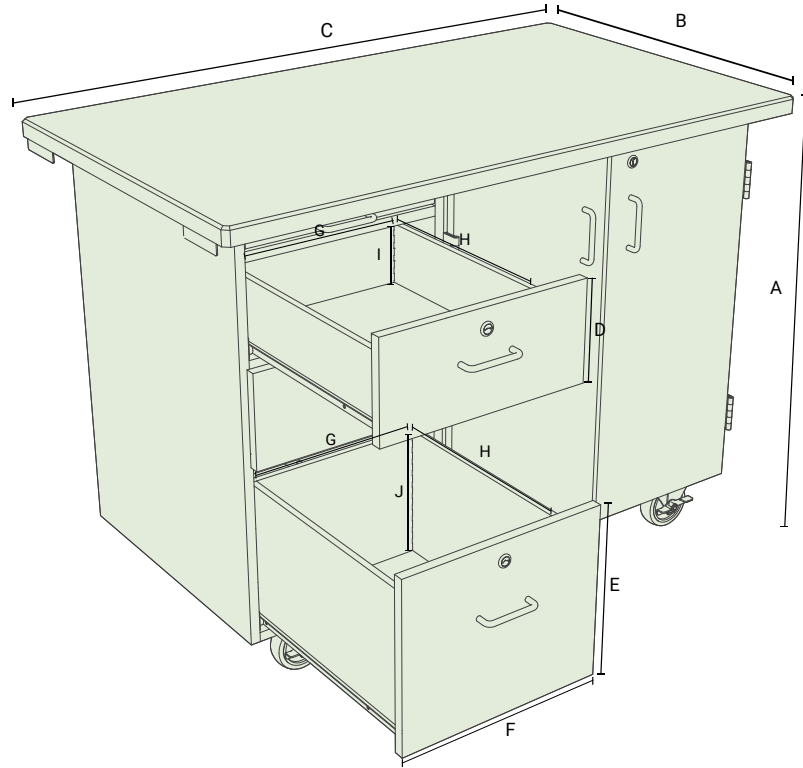

# MSC03SW

MSC03SW	DIMENSIONS (in Inches)
A	69.93
B	27.99
C	48.03
D	28.35
E	9.14
F	21.26
G	12.28
H	26.02
I	15.59
J	13.59
K	5.63
L	13.03
M	27.72
N	20.63
O	6.23-41.81(min-max)
Drawer Weight Capacity	40 LBS

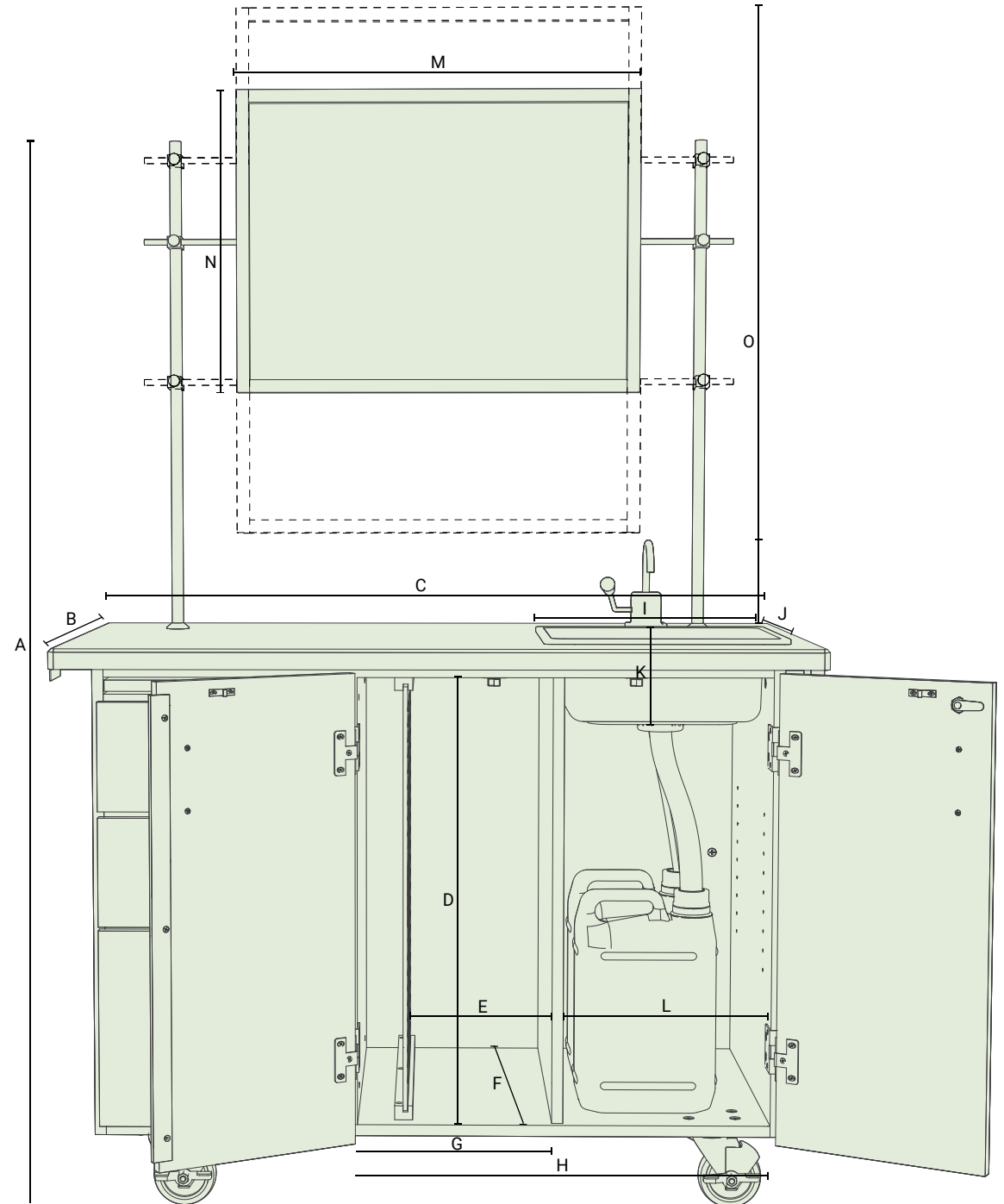



# MSC04

MSC04	DIMENSIONS (in Inches)
A	36.27
B	27.99
C	48.03
D	2.99
E	12.6
F	17.17
G	11.12
H	2.89
I	15.61
J	13.03
K	29.06

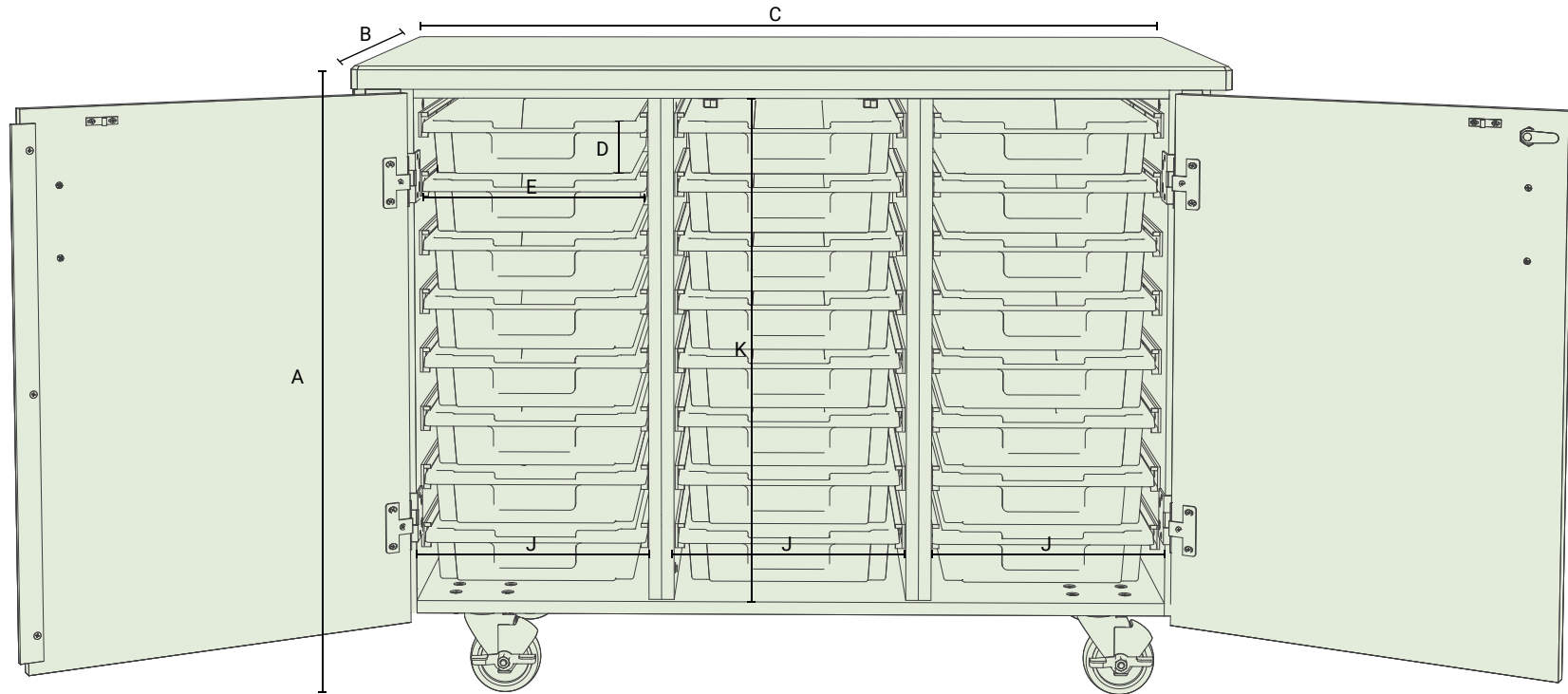
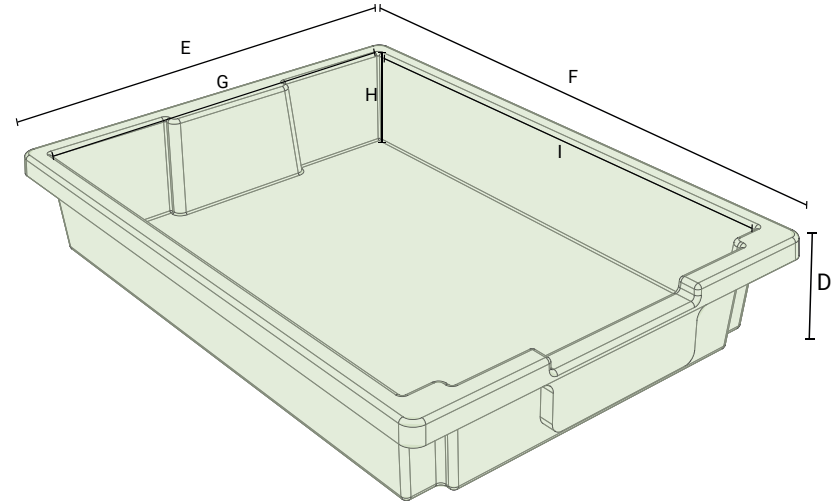

# MSC05

MSC05	DIMENSIONS (in Inches)
A	41.55
B	48.03
C	27.99
D	10.67
E	41.93
F	34.33
G	9.88
H	11.77-21.85 (min-max)
I	6.67
J	6.83

