

BLOW MOLDED PICNIC TABLES



VERSATILE



PORTABLE



DURABLE



*Elevate your
gatherings with our
fold-flat picnic table!*

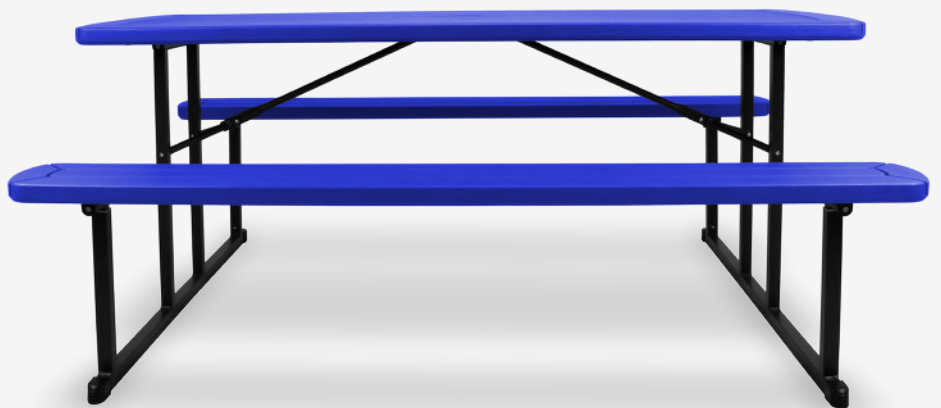

BLOW MOLDED PICNIC TABLES UNIQUE FEATURES

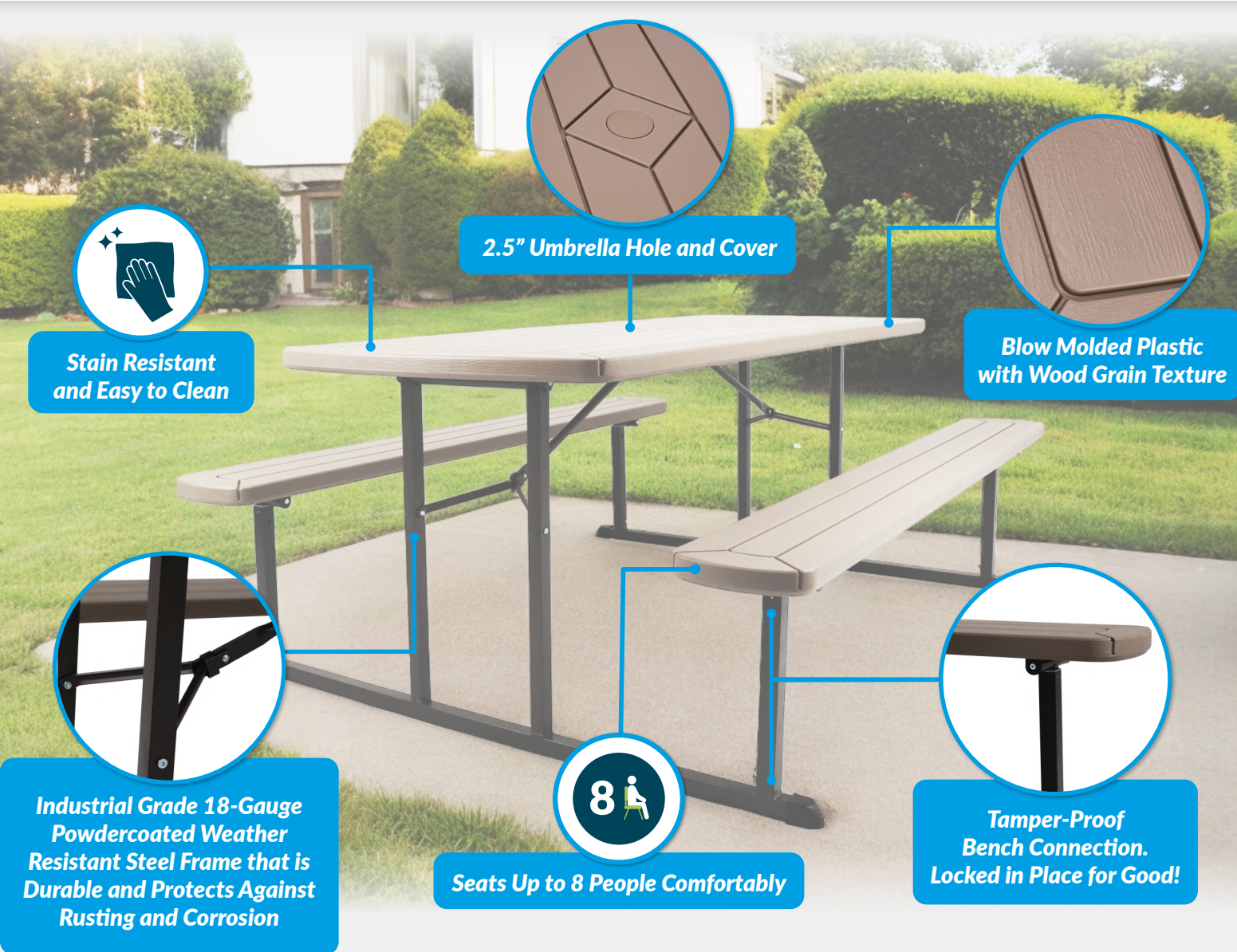

Instant Picnic Magic: Set Up, Enjoy, Store with Ease!

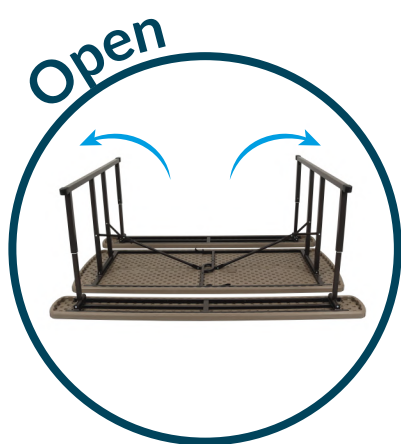



Versatility for Every Gathering



BLOW MOLDED PICNIC TABLES COLOR OPTIONS

*Make every picnic pop with our
range of colorful picnic tables.
Choose your favorite !*

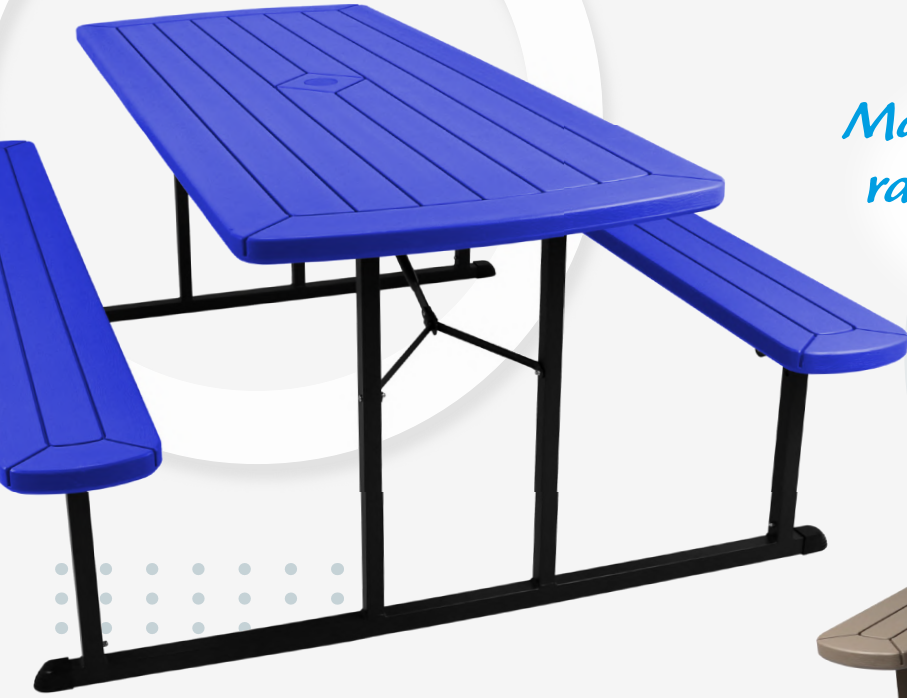





4 COLORS
AVAILABLE









Compactly folds to just 3 inches high, saving valuable storage space!





Colors

			
BMPT3072-BK02 Light Speckled Grey Black Frame	BMPT3072-BR03 Brown Brown Frame	BMPT3072-BK04 Blue Black Frame	BMPT3072-BK06 Green Black Frame

Features

 1.6" Thick Industrial Grade HDPE Blow Molded Tabletop	 Fold-Flat to a Convenient Height of 3" for Easy Storage and Transportation	 2.5" Umbrella Hole and Cover
 Industrial Grade 18-Gauge Framing System	 Gravity Lock with Clicking Mechanism for Added Stability	 Non-Marring Glides for a Secure Footing without Marking Floors

 can withstand heat up to **212°**

 **TABLE WEIGHT CAPACITY 1000 lbs**
evenly distributed

 **BENCH WEIGHT CAPACITY 800 lbs**
evenly distributed

Dimensions

Open dimensions:

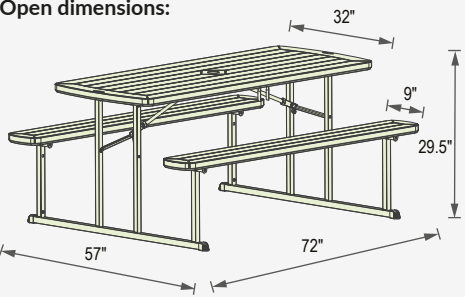

Folded dimensions:
3" H X 57" D x 72" W

