

Installation, Operation
and Maintenance Manual



ecocirc PRO

High efficiency hot water circulation pump

Table of Contents

1	Introduction and Safety	4
1.1	Introduction	4
1.2	Safety	4
1.2.1	Danger levels and safety symbols	4
1.2.2	User safety	5
2	Handling and Storage.....	7
2.1	Handling of the packed unit	7
2.2	Unit inspection upon delivery.....	7
2.2.1	Inspect the package	7
2.2.2	Unpacking and inspection of the unit	7
2.3	Unit handling	8
2.4	Storage	8
3	Technical Description	9
3.1	Designation	9
3.2	Integrated features and functions	9
3.3	Data plate	10
3.4	Model description	10
3.5	Names of the main components and accessories	11
3.6	Intended use.....	12
3.7	Improper use	13
4	Installation	14
4.1	Precautions	14
4.2	Installation area	14
4.3	Hydraulic connection	14
4.3.1	Guidelines for the hydraulic system	15
4.3.2	Installation	16
4.3.3	Rotation of the pump motor	16
4.3.4	Insulation	18
4.4	Electrical connection	18
4.4.1	Ground.....	18
4.4.2	Guidelines for electrical connection.....	19
4.4.3	Guidelines for timer connection	20
5	Use and Operation.....	21
5.1	Precautions	21
5.2	Before starting.....	21
5.3	First starting	21
5.4	Air purge.....	22
5.5	Setting the timer.....	22

5.6	Operation modes	24
5.6.1	Fix speed models	24
5.6.2	Variable speed models	24
5.6.3	Fix speed models with fix value temperature control	24
5.6.4	Fix speed models with variable value temperature control	24
5.6.5	LED light	25
5.6.6	Motor protection from overtemperature	25
5.6.7	Dry run protection	25
5.6.8	Power Down Reset (PDR)	25
5.6.9	Temperature sensor error mode	25
6	Maintenance	26
6.1	Precautions	26
6.2	Maintenance	26
6.3	Disassembly	26
6.4	Replacing the pump motor	27
6.4.1	Replacement motors	27
6.4.2	Pump units for replacement	27
7	Troubleshooting	28
7.1	Precautions	28
7.2	Error signals	28
7.3	Pump not running	28
7.4	Pump running for 1 minute periods only	28
7.5	Pump is noisy	28
8	Technical Information	29
8.1	Operating environment	29
8.2	Pumped liquid	29
8.3	Electrical characteristics	29
8.4	Mechanical characteristics	30
8.5	Dimensions and weights	30
8.6	Hydraulic curves	31
8.7	OEM models	32
9	Disposal	33
9.1	Precautions	33
9.2	WEEE (50 Hz)	33
10	EU Declaration of Conformity	34
11	Warranty	35
11.1	Information	35

1 Introduction and Safety

1.1 Introduction

Purpose of this manual

This manual provides information on how to do the following in the correct manner:

- Installation
- Operation
- Maintenance



CAUTION:

This manual is an integral part of the unit. Make sure to have read and understood the manual before installing the unit and putting it to use.

Failure to follow these instructions can cause personal injury and damage to property, and may void the warranty and result in the loss of all entitlement to claim damages.

NOTICE:

The manual must always be made available to the user either as a printout or as a downloaded and offline stored electronic file.

Supplementary instructions

The instructions and warnings of this manual apply to the standard unit as described in the sale documentation. Special version pumps may be supplied with supplementary instruction manuals. For situations not considered in the manual or in the sales document, contact Xylem or the Authorised Distributor.

1.2 Safety



WARNING:



- The operator must be aware of safety precautions to prevent physical injury.
 - Operating, installing, or maintaining the unit in any way that is not covered in this manual could cause death, serious personal injury, or damage to the equipment. This includes any modification to the equipment or use of parts not provided by Xylem. If there is a question regarding the intended use of the equipment, please contact a Xylem representative before proceeding.
 - Do not change the service application without the approval of an authorized Xylem representative.
-

1.2.1 Danger levels and safety symbols







Before using the unit, the user must read, understand and comply with the indications of the danger warnings in order to avoid the following risks:

- Injuries and health hazards
- Damage to the product and its surroundings
- Unit malfunction

Danger levels

Hazard level	Indication
 DANGER:	It identifies a dangerous situation which, if not avoided, causes serious injury, or even death.
 WARNING:	It identifies a dangerous situation which, if not avoided, may cause serious injury, or even death.
 CAUTION:	It identifies a dangerous situation which, if not avoided, may cause small or medium level injuries.
NOTICE:	It identifies a situation which, if not avoided, may cause damage to property but not to people.

Complementary symbols

Symbol	Description
	Electrical hazard
	Hot surface hazard
	Danger, system pressurized
	Do not use flammable liquids
	Do not use corrosive liquids
	Read the instruction manual

1.2.2 User safety

Electrical hazard

**DANGER: Electrical hazard**

The unit must not be used if the cable or the electrical compartment is damaged. Damaged cable may only be replaced (so that danger is avoided) by the manufacturer, its service agent or a trained professional electrician.

Qualified personnel



WARNING:

This unit must be used only by qualified users. Qualified users are people able to recognise the risks and avoid hazards during installation, use and maintenance of the unit.

Inexperienced users



WARNING:

- **For EU countries:** this product may be used by children aged 8 years and above and persons with reduced physical, sensory or mental capabilities, or who lack experience and knowledge, provided that they are being supervised and have been instructed on how to use it safely, and understand the hazards involved. Children must not play with the product. Cleaning and maintenance must not be carried out by children without supervision.
 - **For countries outside the EU:** this product is not intended for use by persons (including children) with reduced physical, sensory or mental capabilities, or who lack experience and knowledge, unless they are being supervised and have been instructed on how to use it by a person responsible for their safety. Children should be supervised to ensure that they do not play with the product.
-

General safety rules

- Always keep the work area clean.
- Pay attention to the risks presented by gas and vapours in the work area.
- Avoid all electrical dangers. Pay attention to the risks of electric shock or arc flash hazards.
- Always bear in mind the risk of electrical accidents and burn injuries.

Safety equipment

It is recommended to use the proper safety equipment within the work area:

- Hard hat
- Safety goggles
- Protective shoes
- Protective gloves
- Hearing protection

Electrical connections

Electrical connections must be made by certified electricians in compliance with all international, national, state, and local regulations.

Precautions before work

Observe these safety precautions before you work with the product:

- Make sure that you have a clear path of retreat.
- Allow all system and pump components to cool before you handle them.
- Make sure that the product has been thoroughly cleaned.
- Disconnect and lock out power before you service the pump.

Precautions during work

Observe these safety precautions when you work with the product:

- Rinse the components in water after you disassemble the pump.
- Do not exceed the maximum working pressure of the pump.
- Do not open any vent or drain valve or remove any plugs while the system is pressurized. Make sure that the pump is isolated from the system and that pressure is relieved before you disassemble the pump, remove plugs, or disconnect piping.

2 Handling and Storage

2.1 Handling of the packed unit



WARNING:

Take appropriate measures during transport, installation and storage to prevent contamination from external substances.

The Manufacturer delivers the unit and its components in a cardboard box.

2.2 Unit inspection upon delivery

2.2.1 Inspect the package

1. Check that quantity, descriptions and product codes match the order.
2. Check the packaging for any damage or missing components.
3. In case of immediately detectable damage or missing parts:
 - accept the goods with reserve, indicating any findings on the transport document, or
 - reject the goods, indicating the reason on the transport document.

In both cases, promptly contact Xylem or the Authorised Distributor from whom the product was purchased.

2.2.2 Unpacking and inspection of the unit



CAUTION: Cut and abrasion hazard

Always wear personal protective equipment.

1. Remove packing materials from the product. Dispose of all packing materials in accordance with local regulations.
2. Check the unit for integrity and to make sure that there are no missing components.
3. In case of damage or missing components, promptly contact Xylem or the Authorised Distributor.

Content of the package

- Pump unit
- Thermal insulating shell
(for models 15-_/65B, 15-_/110MB and 15-_/110LB only)
- Check valve - G1/2
(for models 15-_/65B only)
- Sealing ring for foreign pump housings - Ø61/Ø54x3.55 mm
(for models 15-_/65B, 15-_/110MB and 15-_/110LB only)
- Sealing ring for foreign pump housings - Ø60.8/Ø54x5 mm
(for models 00-_/000 only)
- Spacer ring for foreign pump housings - Ø54/Ø52x2 mm
(for models 00-_/000 only)
- Safety Instructions and Quick Startup Guide

2.3 Unit handling



DANGER: Electrical hazard

Holding the unit by the supply cord is strictly forbidden.



WARNING:

During handling, make sure to avoid injury to people and animals, and/or damage to property.

2.4 Storage

Storage of the packed unit

The unit must be stored:

- In a covered and dry place
 - Away from heat sources
 - Protected from dirt
 - Protected from vibrations
 - At an ambient temperature between -40 °C and 85 °C (-40 °F and 185 °F), and relative humidity between 5 % and 95 %.
-

NOTICE:

Do not place heavy loads on top of the unit.

NOTICE:

Protect the unit from collisions.

3 Technical Description

3.1 Designation

Domestic hot water circulation pump for drinking water only (EU Regulation No. 622/2012).

OEM applications

For special OEM applications the pump has customized versions, which differ from the standard versions in one or more features of the followings:

- Special software functions
- Customized power supply cable (special connectors or terminals)
- Alternative circulating fluid

3.2 Integrated features and functions

Identification based on part number:

	60A__0...	60A__1...	60A__2...	60A__3...	60A__4...	60A__5...	60A__6...
Fix speed	●				●		
Variable speed		●				●	
PWM control			●				
Temperature control				●			●
Timer control					●	●	●
Standby mode		●		○*		●	○*
Air purge function		●		○*		●	○*
Error code flashing LED light		●		○*		●	○*
Dry run protection	○**				○**		
Power Down Reset	○**				○**		

* The function is available only in models with potentiometer knob

** The function is available only in special OEM models

Identification based on model description:

	15-_/65B	15-_/65S	15-_/110MB	15-_/110LB	00-_/000
Brass pump housing	●		●	●	
Stainless steel pump housing		●			
No pump housing (replacement part)					●
Integrated shut-off valve			●	●	
Integrated check valve			●	●	
Internal G1/2 thread connections	●	●	●	●	
External G3/4 thread connections			●		
External G1 1/4 thread connections				●	

3.3 Data plate

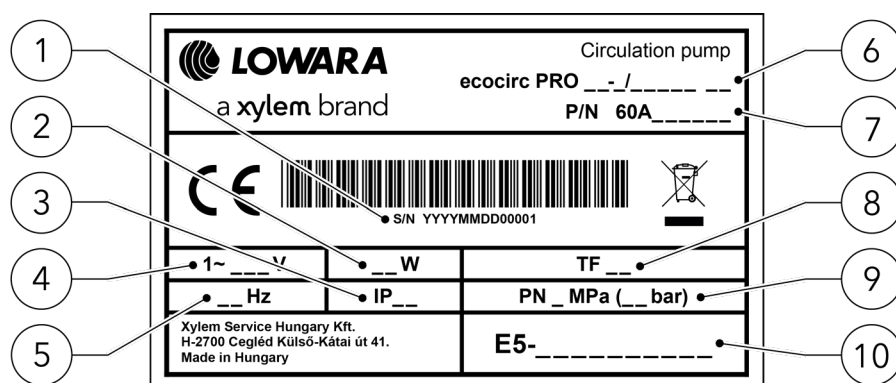

Figure 1

No.	Description	No.	Description
1	Serial number incl. manufacturing date	6	Model description
2	Input power	7	Part number
3	Ingress protection class	8	Operational temperature class
4	Rated voltage	9	Nominal system pressure
5	Frequency	10	Technical code

3.4 Model description

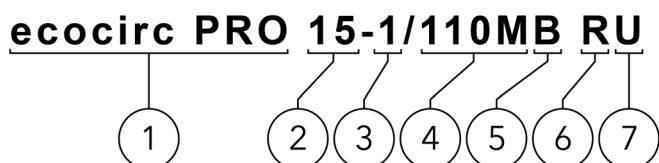

Figure 2

No.	Description	Notes
1	Series name	ecocirc PRO
2	Nominal diameter of connections	15 = DN15 00 = drive unit (delivered without pump housing)
3	Maximum head	1 = 1 m 3 = 3 m
4	Pump housing port-to-port distance and connection threads	65 = 65 mm (with G1/2 connections) 110M = 110 mm (with G3/4 connections) 110L = 110 mm (with G1 1/4 connections) 000 = drive unit (delivered without pump housing)
5	Pump housing material	B = brass S = stainless steel P = plastic
6	Temperature sensor	Empty = without temperature sensor R = with temperature sensor
7	Timer control	Empty = without timer U = with built-in timer

3.5 Names of the main components and accessories

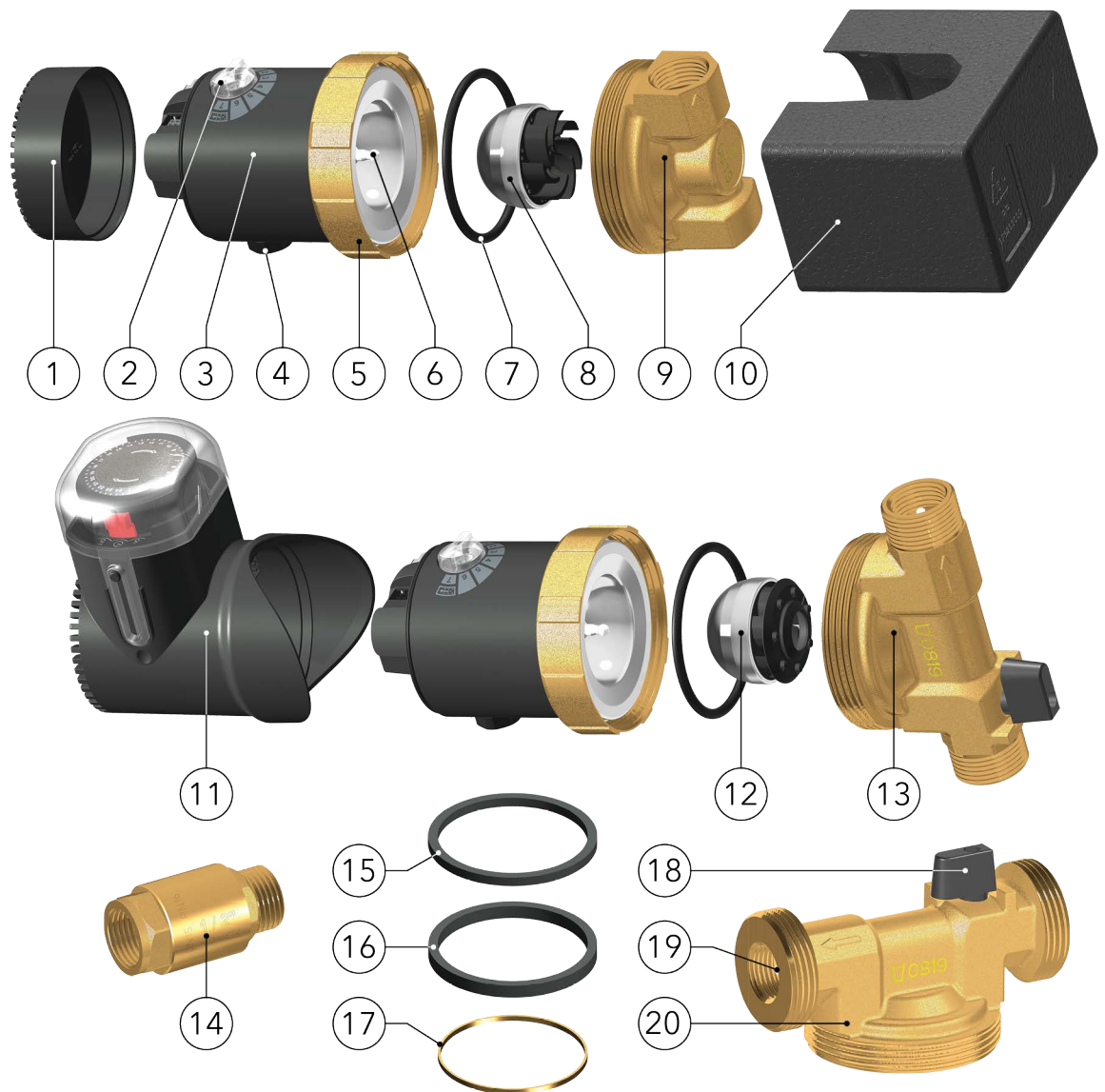

Figure 3

No.	Description	No.	Description
1	End cap	11	Timer
2	Potentiometer knob	12	Rotor with closed impeller
3	Stator (pump motor)	13	Pump housing G3/4 (code: 110MB)
4	Cable gland	14	Check valve with G1/2 threads
5	Union nut	15	Sealing ring - Ø61/Ø54x3.55 mm
6	Ceramic bearing ball	16	Sealing ring - Ø60.8/Ø54x5 mm
7	O-ring	17	Spacer ring - Ø54/Ø52x2 mm
8	Rotor with open impeller	18	Integrated ball shut-off valve
9	Pump housing G1/2 (code: 65B)	19	Integrated check valve
10	Thermal insulation shell	20	Pump housing G1 1/4 (code: 110LB)

3.6 Intended use

Circulation pump for domestic hot water systems.

If hot water is not used for longer periods of time, the water in the hot water pipe cools off. Domestic hot water pumps (also called sanitary or drinking water circulation pumps) pump this cold water back into the water heater via a separate circulation pipe (see **Figure 4** on page **15**). At the same time fresh hot water is flowing out of the water heater and provides a constant supply of hot water at the tap.

The ecocirc PRO series drinking water circulation pumps are suitable for single- and two-family homes with a circulation pipe length of approx. 50 m.

Pumped liquids

NOTICE:

This circulator is suitable for drinking water only - EU Regulation No. 622/2012

For use with alternative circulating fluids (e.g. in special OEM applications) contact Xylem or the Authorised Distributor.

The liquids must be:

- Clean
- Free of solid - especially metallic - particles or fibres
- Free of mineral oils
- Chemically and mechanically non aggressive
- Non-flammable
- Non-explosive

Observe the operating limits in **Technical Information** on page **29**.



WARNING:

It is prohibited to pump drinking water after use with other fluids.



WARNING:

Take appropriate measures during transport, installation and storage to prevent contamination from external substances.



WARNING:

Remove the unit from its packaging just before installation to prevent contamination from external substances.



WARNING:

After installation, run the unit for a few minutes with several utilities open in order to wash the inside of the system.

3.7 Improper use

**WARNING:**

The unit was designed and built for the use described in the **Intended Use** section on page 12. Any other uses are prohibited, as they could compromise the safety of the user and the efficiency of the unit itself.

**DANGER:**

It is prohibited to use this unit to pump flammable and/or explosive liquids.

**DANGER: Potentially explosive atmosphere hazard**

It is prohibited to start the unit in environments with potentially explosive atmospheres or with combustible dusts.

**DANGER:**

In domestic hot water systems, the water is recommended to be pumped at a temperature above 50 °C (122 °F) to prevent the risk of legionella.

**DANGER:**

In domestic hot water systems, flexible pipes must not be used to connect the unit to the mains water supply.

**CAUTION:**

It is prohibited to use the unit to pump aggressive liquids, acids and seawater.

Examples of improper use

- Pumping liquids not compatible with the construction materials of the unit.
- Pumping liquids with temperatures higher than what shown in **Technical Information** on page 29.
- Pumping hazardous, toxic, explosive, flammable or corrosive liquids.
- Pumping seawater.

4 Installation

4.1 Precautions

Before starting, make sure that the safety instructions shown in **Introduction and Safety** on page 4 have been fully read and understood.



DANGER: Potentially explosive atmosphere hazard

It is prohibited to start the unit in environments with potentially explosive atmospheres or with combustible dusts.



WARNING:

Always wear personal protective equipment.



WARNING:

Always use suitable working tools.



WARNING:

When selecting the place of installation and connecting the unit to the hydraulic and electric power supplies, strictly comply with current regulations.



WARNING:

It is prohibited to pump drinking water after use with other fluids.



WARNING:

Remove the unit from its packaging just before installation to prevent contamination from external substances.

4.2 Installation area

- Only install in dry rooms where the pump and the piping is protected from freezing.
- Install in one of the permitted mounting positions (see **Figure 5** on page 16).
- Observe the instructions given in the **Operating environment** section on page 29.

4.3 Hydraulic connection



DANGER:

All the hydraulic and electrical connections must be completed by a technician possessing the technical-professional requirements outlined in the current regulations.



WARNING:

Piping must be sized to ensure safety at the maximum operating pressure.



WARNING:

Install appropriate seals between the unit couplings and the piping system.

4.3.1 Guidelines for the hydraulic system

- If possible, install the unit at the lowest point of the system.
- Support the pipes independently so that their weight does not load the unit.
- Remove any welding residues, deposits and impurities in the pipes that could damage the unit.
- Check that other units do not come in contact with the unit.
- When using pump models with pump housing code 65B (item 9 in **Figure 3**), use the G1/2 check valve (item 14 in **Figure 3**) supplied in the packaging. This prevents water from flowing through the pump backwards when any faucet is opened, thus causing damage.
- When using a check valve other than the factory supplied one, pay attention to the appropriate closing pressure.
- Install the check valve after the pump in the direction of flow, so that the arrows on the pump housing and on the check valve point in the same direction.
- We recommend that for pump models with pump housing code 65B, you install a ball shut-off valve before the pump at least, for future maintenance or repair works.
- Pumps with pump housings code 110MB (item 13 in **Figure 3**) and code 110LB (item 20 in **Figure 3**) already contain an integrated check valve (item 19 in **Figure 3**) and a ball shut-off valve (item 18 in **Figure 3**) in the pump housings. (The check valve opens and closes automatically; the ball shut-off valve is closed when its handle is perpendicular to the pipe direction).
- With the shut-off valve closed at the suction side of the pump and with the check valve installed at the discharge side, the union nut (item 5 in **Figure 3**) can be loosened, thus the pump motor can be turned in proper position, or even removed for maintenance without completely draining the system.
- To be able to exclude the complete unit from the system, e.g. for replacement of the pump housing without draining the system, install additional shut-off valves both at the suction and at discharge side of the pump.

The next figure shows a typical installation:

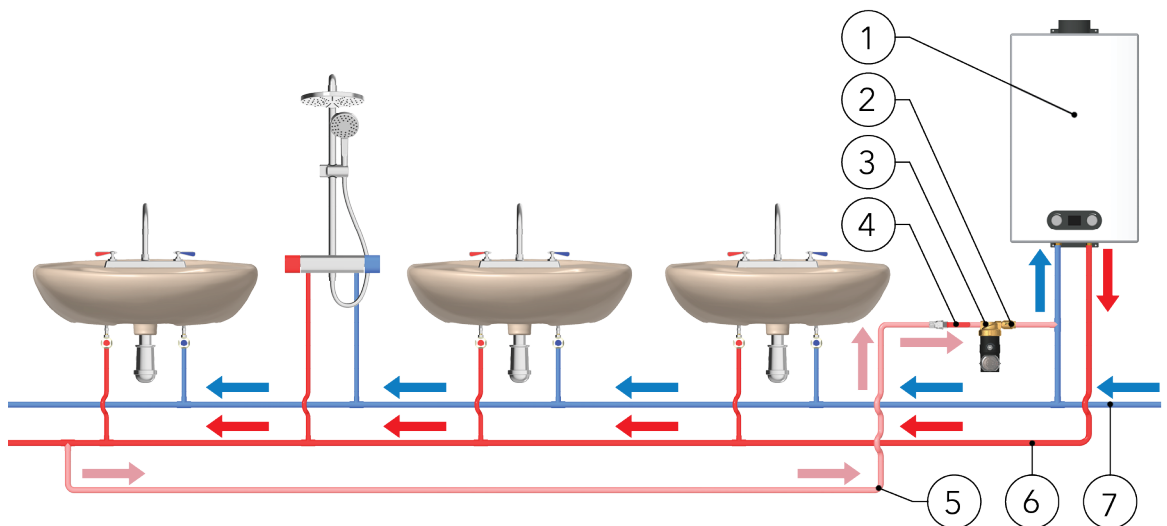

Figure 4

No.	Description	No.	Description
1	Water heater	5	Hot water return line
2	Check valve	6	Hot water supply line
3	Circulation pump	7	Cold water supply line
4	Ball shut-off valve		

4.3.2 Installation



WARNING: Danger, system pressurized

Before starting work, close the shut-off valves on the suction and discharge sides or drain the system.

Installation Sequence

1. Identify the arrow, cast on the pump housing to define the flow direction of the liquid.
2. Insert the unit between the pipes, in one of the permitted mounting positions, using the proper gaskets or thread seal.
3. Tighten the connections.

Permitted positions

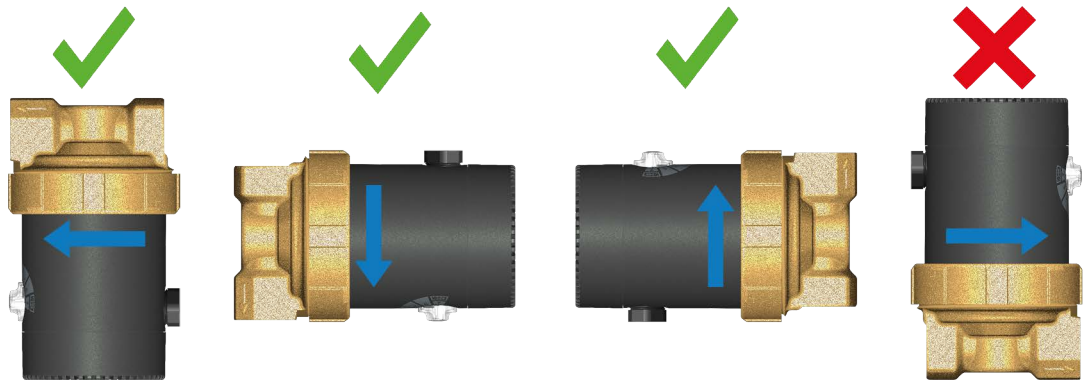

Figure 5

4.3.3 Rotation of the pump motor



WARNING: Danger, system pressurized

Before starting work, close the shut-off valves on the suction and discharge sides or drain the system.



ATTENTION:

During the loosening of the union nut from the pump housing, it is possible the leakage of residual very hot or cold liquid: pay attention to the risk of damages to persons.



ATTENTION:

Be careful not to damage the internal seal: risk of leakage of very hot or cold liquid during the operation of the unit.

When installing pumps with a potentiometer knob and/or a timer in a vertical position, the pump motor may be turned in 360° steps, so that the knob and/or the timer may be positioned in a well visible orientation (see **Figure 6** on page 17).

1. Loosen the union nut before installation.
2. Rotate the pump motor to the required installation position.
3. Tighten the union nut.

When installing the pump in a horizontal position, the timer shall point upwards. It may be turned in the range from 10:30 to 13:30 ($\pm 45^\circ$) at maximum, in order to maintain protection class IP 42 (see **Figure 7** on page 17).

Rotating the pump motor (vertical installation)

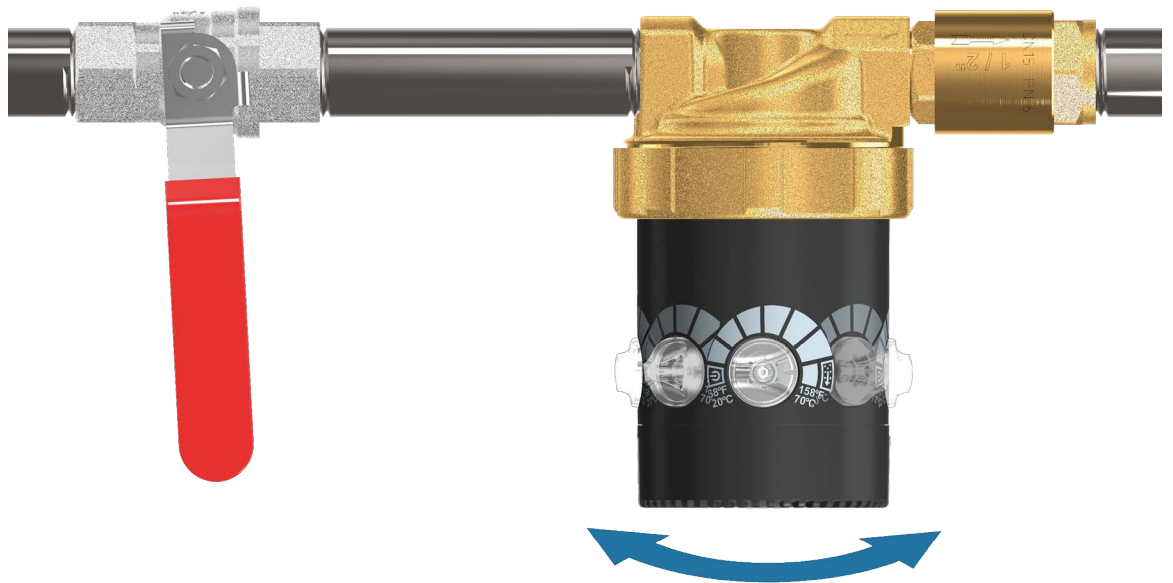

Figure 6

Rotating the pump motor (horizontal installation)

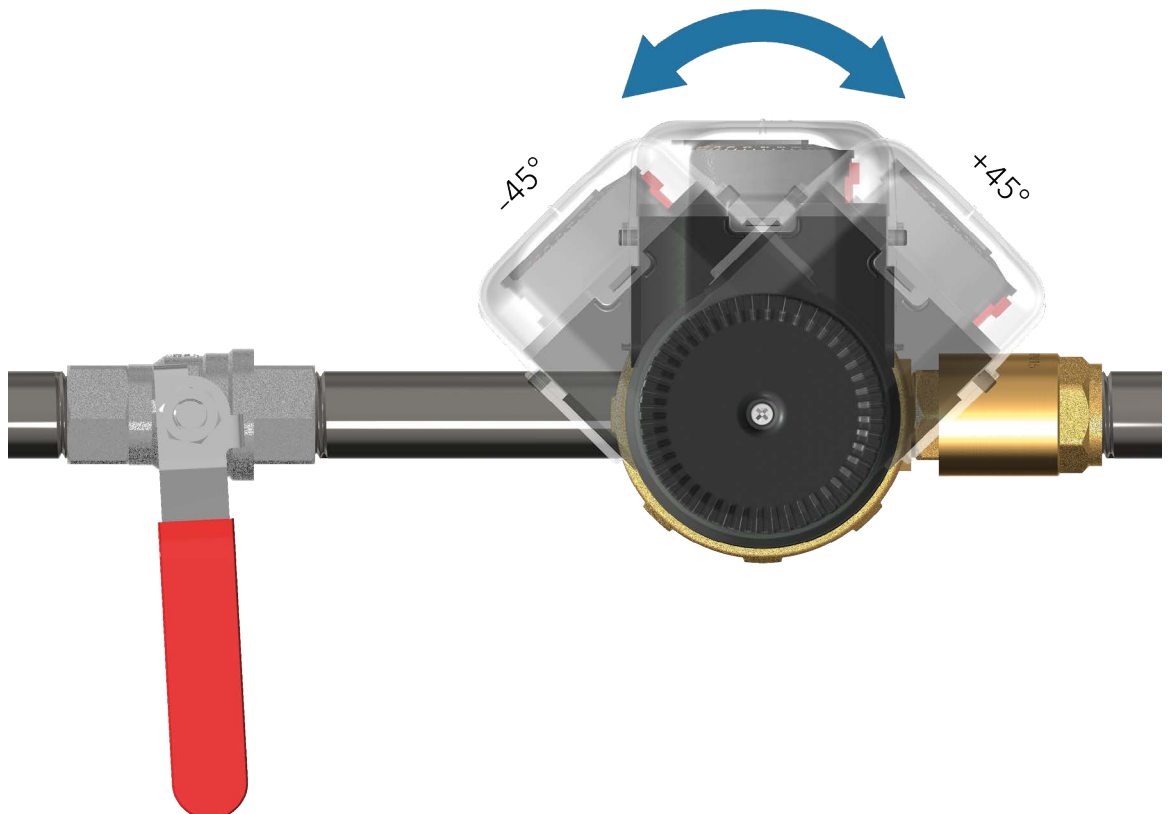

Figure 7

4.3.4 Insulation

To save energy, insulate the pump housing with the matching thermal insulation shell (item 10 in Figure 3) included in the package (see Figure 8).

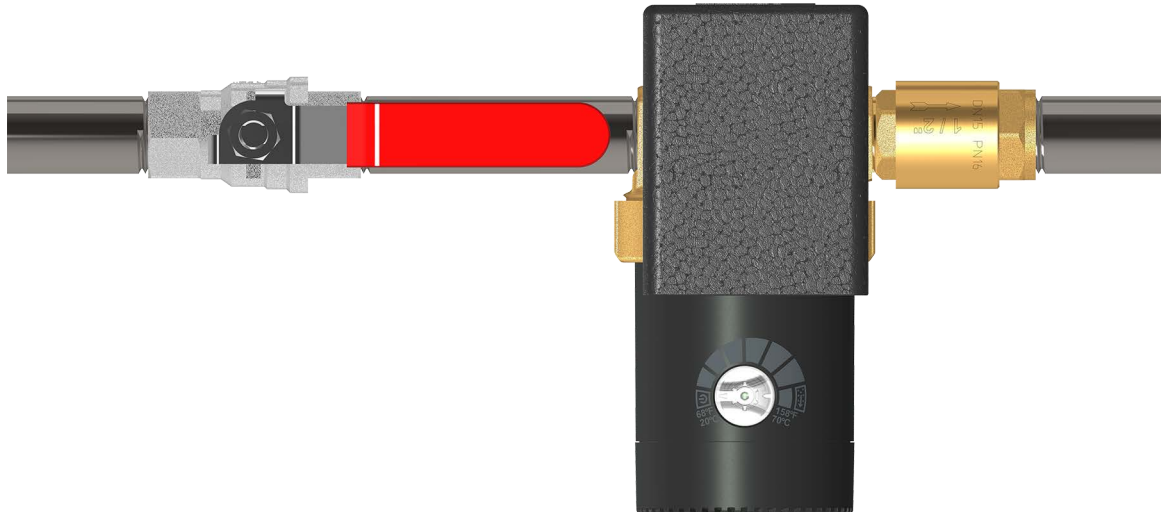

Figure 8

4.4 Electrical connection



DANGER:

All the hydraulic and electrical connections must be completed by a technician possessing the technical-professional requirements outlined in the current regulations.



DANGER: Electrical hazard

Before starting work, check that the unit is unplugged and that the pump unit cannot restart, even unintentionally.

4.4.1 Ground



DANGER: Electrical hazard

Always connect the external protection conductor (ground) to the ground terminal before attempting to make any other electrical connections.



DANGER: Electrical hazard

Connect the pump unit and any electric accessories to a socket with protection conductor (ground).



DANGER: Electrical hazard

Check that the external protection conductor (ground) is longer than the phase conductors; In case of accidental disconnection of the unit from the phase conductors, the protection conductor must be the last one to detach itself from the terminal.



DANGER: Electrical hazard

Install suitable systems for protection against indirect contact, in order to prevent lethal electric shocks.

4.4.2 Guidelines for electrical connection

- Check that the mains voltage and frequency match the specifications on the data plate.
- Protect the supply cord from high temperatures, vibrations, collisions and abrasions.
- Check that the power supply line is provided with a short circuit protection device of appropriate size.
- If the pump unit is supplied with a power cord with grounding-type attachment plug, connect it only to a properly grounded, grounding-type receptacle.
- Do not use an extension cord.
- If the pump unit is supplied without a power cord, use only a <HAR> and/or <VDE> approved, ordinary duty, PVC insulated and sheathed, flexible power cable with copper conductors, type H05V2V2-F, with a cross section of 3G0.75 and with a minimum sheath diameter of 6.7 mm. Follow the following connection steps.

Power cord connection

<p>1. Prepare the power cord:</p> <ul style="list-style-type: none"> • Strip the wires according to the next dimensions. • Coat the stripped copper cores with lead free solder or apply end splices of a proper size. 	
<p>2. Unscrew the cable gland components from the motor housing.</p>	
<p>3. Install the cable gland components onto the prepared cable. Take care of the proper order and orientation.</p>	
<p>4. Remove the screw that holds the end cap to the motor housing, and remove the end cap.</p>	

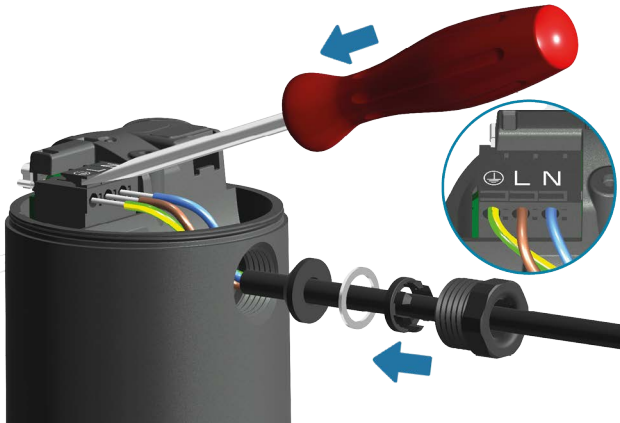
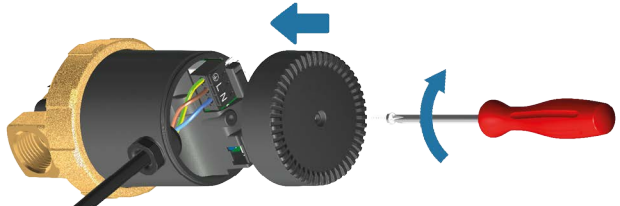
<p>5. Cable installation:</p> <ul style="list-style-type: none"> • Insert the cable through the threaded hole into the motor housing. • Push the lever of the terminal block with a flat screw driver and get each stripped core into the proper hole. • Take care of matching the markings of the terminal block with the proper cable colours. • The whole stripped conductor length must be inside of the terminal block. • Insert the cable gland components into the housing and tighten the nut. 	
<p>6. Final assembly:</p> <ul style="list-style-type: none"> • Put the end cap back to the motor housing. • Take care of its orientation, only one angular position is correct. • Tighten the screw with 0.6 Nm. 	



DANGER: Electrical hazard

Before the electrical connection is energized, the electrical compartment must be closed.



DANGER: Electrical hazard

Pumps, that do not equipped with standard power supply plug, may only be connected to the electrical system in a separate protective box. For identification, check the 8th character of the technical code (counting after the prefix "E5-") of the product (see Item 10 on Figure 1), codes C, S, and X are affected.

NOTICE:

Before the electrical connection is energized, the pump unit must be filled with water; if not, the bearings will be destroyed by dry operation.

4.4.3 Guidelines for timer connection

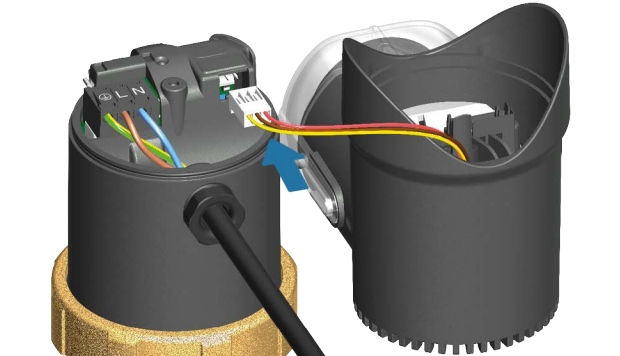
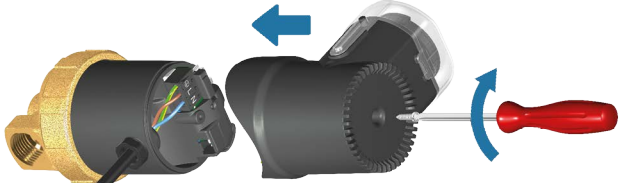
<p>1. Follow the steps 1. to 5. of section 4.4.2.</p>	
<p>2. Connect the 3-pin connector of the timer into the proper opening of the motor housing.</p>	
<p>3. Final assembly:</p> <ul style="list-style-type: none"> • Put the timer to the motor housing. • Take care of its orientation, only one angular position is correct. • Tighten the screw with 0.6 Nm. 	

5 Use and Operation

5.1 Precautions



WARNING

Make sure that the discharged liquid cannot cause damage to persons or things.



WARNING: Electrical hazard

Check that the unit is properly connected to the mains power supply.



WARNING: Hot surface hazard

Motor housing may be very hot. Burn hazard. Do not touch.

NOTICE:

Dry run of the unit is prohibited, as this can destroy the bearings in a very short time.

NOTICE:

It is prohibited to operate the unit with the shut-off valve closed.

5.2 Before starting

Before ever starting the pump, verify that:

- The instructions in section **Installation** on page **14** have been performed.
- The system has been flushed thoroughly to prevent foreign objects and impurities from blocking the pump.
- The system has been filled and air purged (see section **Air Purge** on page **22**).

5.3 First starting

1. Connect the plug to the mains.
 - In case of models without potentiometer knob, the pump starts to operate immediately.
 - In case of models with potentiometer knob the unit stays idle (Standby mode) or starts to operate depending on the position of the knob (see **Figure 9** for the different scale layouts).



Figure 9

2. With the unit in operation, check that:
 - No liquid is leaking from the pipes.
 - There is no unwanted noise or vibrations.
 - Liquid is actually being pumped.

5.4 Air purge

After filling the system with liquid, any residual air shall be removed from the pump housing. To aid this effort, the standard pump models with potentiometer knob are equipped with a built-in air purge function.

For activation, turn the knob to the right end position for 5 seconds (the air purge symbol is shown on the scale, see **Figure 10**). A 10 minute long air purging sequence starts, which includes several max and min speed sequences, stoppages. It is indicated with the knob flashing green. You may set the knob to the desired speed level during the air purge sequence. After the sequence is finished, the pump will continue to operate in the preset speed level.

You can interrupt the air purge sequence via turning the knob under its halfway position and turning it back to the end position again. Or simply switch off and then on the mains power. Audible flow noises indicate if there is still air in the pump. In this case repeat the air purging.



Figure 10

5.5 Setting the timer



To increase the overall efficiency of a hot water recirculation system, some pump models are equipped with a plug-in timer unit (it is also available as an installation kit for retrofitting; for ordering, contact your local distributor). The timer control is programmable to turn the circulator on and off automatically at preset times. This allows domestic hot water to be circulated only at the expected times of high usage.

NOTICE:

The timer mechanism allows turning the setting dial only in clockwise direction (as indicated by the arrows as well). Do not force it counterclockwise, it may damage the unit.

Timer programming

<p>1. Using a small flat-head screwdriver, pry the timer cover open and fold it under the unit.</p>	
<p>2. Set the current time by turning the setting dial in the direction of the arrows, until the actual time is aligned with the pointer above the dial face. The illustration shows the correct setting in case the actual time is 6 a.m. The scaling is for a whole 24 hours in a graduation of 30 minutes. The ratchet mechanism allows turning the dial only in clockwise direction, do not force it counterclockwise. One "click" represents approx. 5 minutes.</p>	

<p>3. Program the on/off times by pulling the tabs outward until flushing with the dial face for the pump to operate on during selected time periods. Push the tabs inward, one step behind the dial face for the pump to remain off during the selected time periods. Each timer tab covers a 30-minute period. The illustration shows a setting, where the pump is to be in operation between 4 a.m. and 2 p.m.</p>	
<p>4. Move the red slider to: "On" for continuous running "Off" to turn the circulator off "⌚" for running according to the program, that is selected by the tabs</p>	
<p>5. Close the timer cover in order to maintain the ingress protection class.</p>	

In the case of a power outage, the timer must be adjusted for the correct time of day after power is restored.

Timer retrofitting

If you install the timer as retrofitting, follow the instructions of section 4.4.2 (only point 4.) and section 4.4.3 (points 2. - 3.).



DANGER:

All the hydraulic and electrical connections must be completed by a technician possessing the technical-professional requirements outlined in the current regulations.



DANGER: Electrical hazard

Before starting work, check that the unit is unplugged and that the pump unit cannot restart, even unintentionally.



DANGER: Electrical hazard

The timer has both a 115 V / 60 Hz and a 230 V / 50 Hz versions. Before purchasing check it for the proper supply voltage.

NOTICE:

When purchasing a timer kit for retrofitting, take care of choosing the proper timer model. Pumps produced before 2020 (with 8 bit electronics) has a different timer connection than the ones produced starting from 2020 (with 32 bit electronics). The timers with different connectors are not interchangeable.

5.6 Operation modes

According to the chart in section 3.2 on page 9, the different pump versions have different integrated functions, thus operation modes.

5.6.1 Fix speed models

These pumps are not equipped with a potentiometer knob; run on a constant speed if energized, until reaching the power limit, then the speed may be reduced.

Timer controlled version is available, standby and air purge functions are not available.

5.6.2 Variable speed models

These pumps are equipped with a potentiometer knob, with which the speed can be controlled stepless between a factory preset minimum and maximum value. For reference see the hydraulic curves at the dedicated speeds based on the scaling of 1 - 7 on page 31.

Timer controlled version is available, standby and air purge functions are standard, except some special OEM versions.



Figure 11

5.6.3 Fix speed models with fix value temperature control

These pumps are not equipped with a potentiometer knob; run on a constant speed if energized, until reaching the factory preset temperature limit; it is around 36 °C (97 °F) as default, then the pump stops and switches to standby mode. When the fluid cools back to around 33 °C (91 °F) the pump restarts.

Timer controlled version is available, standby and air purge functions are not available.

5.6.4 Fix speed models with variable value temperature control

There are two versions:

- Adjustable switch off temperature (see **Figure 12** left side view). The desired switch off temperature can be selected between 20-70 °C (68-158 °F) using the selector knob. The pump stops when it reaches the set temperature (switches to standby mode). When the fluid cools back with 3 °C (5.4 °F) under the switch off temperature, the pump restarts.
- Adjustable restart temperature (see **Figure 12** right side view). The factory preset temperature limit is around 36 °C (97 °F) as default, reaching this value the pump stops and switches to standby mode. The desired restart temperature can be selected between 33-25 °C (91-77 °F) using the selector knob. When the fluid cools back to the set temperature, the pump restarts.

Timer controlled version is available, standby and air purge functions are standard, except some special OEM versions.

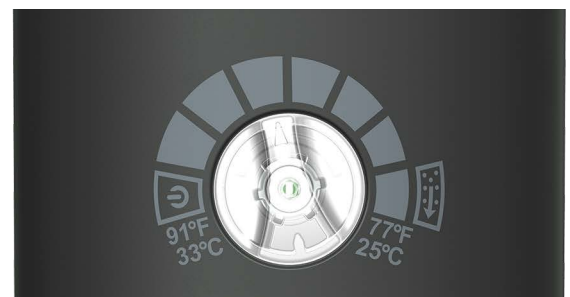

Figure 12

5.6.5 LED light

The standard pump models with potentiometer knob, have a green operation light integrated in the knob. It indicates the main operating modes and the error codes as well, if any is present. This function may be switched off in some special OEM versions.

Mode indications:

Operating mode	LED light status
Normal operation, the pump is running	Continuous on
Air purge sequence is active	Blinking 200 ms on - 200 ms off - 200 ms on...
Standby mode	Blinking 50 ms on - 1.5 s off - 50 ms on...

For error codes see section **Error signals** on page 28.

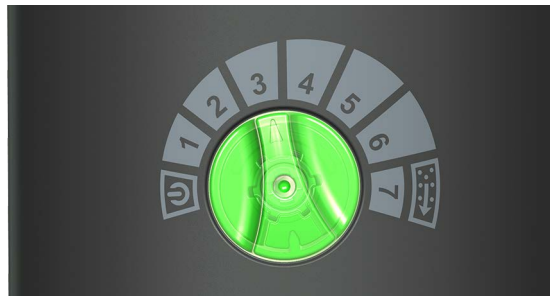

Figure 13

5.6.6 Motor protection from overtemperature

In order to protect the electronics inside the pumps from temperatures that are dangerously high, the pump is equipped with an internal temperature sensor and a self-protecting algorithm. The temperature is measured directly at the electronics. When the temperature of the electronics is between 105 °C and 115 °C (221-239 °F), the pump power is continuously lowered to minimum power and thus the flow of water is also decreasing. If despite the power regulation the temperature still rises and reaches around 125 °C (257 °F), the pump stops completely. Once the electronics have cooled down again to around 115 °C (239 °F) the pump automatically restarts.

5.6.7 Dry run protection

This function is available only for some fix speed models. This algorithm protects the unit from dry running during normal operation.

The pump monitors the input power level and if it drops below a preset value for a specified time interval, the pump starts a sequence with 9 cycles of 30 s on and 60 s off, then a 10-minute pause and so on, until the expected power level restored and the pump can continue the normal operation.

5.6.8 Power Down Reset (PDR)

This function is available only for some fix speed models. This algorithm protects the unit from dry running during normal operation.

This algorithm is a special version of the dry run protection.

If the expected power level cannot be restored in 3 x 9 cycles, described in the section 5.6.7, the pump stops and restarts only after the termination of the power supply.

5.6.9 Temperature sensor error mode

This function is available only for some temperature controlled models. It is activated if the signal from the water temperature sensor is interrupted. In this case the pump runs in a kind of emergency mode with repeating the operation cycle of 1 minute running - 1 minute standby mode. In this situation the pump will not react on the potentiometer knob settings anymore, the operation can only be stopped by disconnecting the power supply.

6 Maintenance

6.1 Precautions

Before starting, make sure that the instructions shown in section **Introduction and Safety** on page 4 have been fully read and understood.



WARNING:

Maintenance must be done by a technician possessing the technical-professional requirements outlined in the current regulations.



WARNING:

Always wear personal protective equipment.



WARNING:

Always use suitable working tools.



WARNING:

In the case of liquids that are excessively hot or cold, pay attention to the risk of injury.



DANGER: Electrical hazard

Before starting work, check that the unit is unplugged and that the pump unit cannot restart, even unintentionally.

6.2 Maintenance

- Check the integrity of the supply cord every 6 months of operation; if the cable is damaged contact Xylem or the Authorised Distributor for its replacement. Do not use the unit with damaged cord.
- Carefully clean the unit from outside.

6.3 Disassembly

Pumps are subject to wear. If the pump is blocked or grinding noises are audible, check the pump and replace it if necessary.

Procedure:

- Disconnect pump from the mains.
- Close the connecting pipelines.
- Loosen the union nut and remove the motor. Residual water may leak out of the rotor cavity. Prevent the electrical connection to the pump from getting wet.
- Check for any foreign object in the rotor cavity, if you find any, remove it.
- Check for wear marks on the rotor cavity and magnet surface. If there are many, the pump has worn off and shall be replaced.
- For reconnection/new pump installation follow the installation rules.

6.4 Replacing the pump motor

6.4.1 Replacement motors

The pump is also available as a drive unit, without pump housing (models 00-_/000) for replacement.

Depending on the pump, what is to be replaced, different seals need to be used.

1. Replacing an old - type identical - pump motor, keeping its own old pump housing in the piping, with a new replacement pump motor:
 - Use the additionally included, 5 mm thick flat seal (item **16** in **Figure 3**) supplied with the replacement unit.
 - The blade height of the rotor, supplied with the replacement motors is lower than that of the original rotor, therefore the hydraulic performance will be reduced after the change.
2. Replacing an old - not type identical - pump motor on its own pump housing, provided that its geometry is fitting, with a new replacement pump motor:
 - Use the additionally included, 5 mm thick flat seal (item **16** in **Figure 3**) supplied with the replacement unit.
3. Replacing an old WILO pump motor on a WILO pump housing with a new replacement pump motor:
 - Use the additionally included, 5 mm thick flat seal (item **16** in **Figure 3**) with the brass spacer ring (item **17** in **Figure 3**) inserted inside supplied with the replacement unit.
 - The spacer ring is to set the proper distance between the pump housing and the rotor.

Corresponding replacement list available on request.

The hydraulic curves on page **31** are not valid for replacement motors.

6.4.2 Pump units for replacement

The standard pump units can be also used for replacement. It is recommended to use this option, if it is important to maintain the original hydraulic performance.

1. Replacing an old - type identical - pump motor, keeping its own old pump housing in the piping, with the motor of a new standard pump unit:
 - Use the new o-ring (item **7** in **Figure 3**) pre-installed in the new pump unit.
2. Replacing an old - not type identical - pump motor on its own pump housing, provided that its geometry is fitting, with the motor of a new standard pump unit:
 - Use the additionally included, 3.55 mm thick flat seal (item **15** in **Figure 3**) supplied with the pump unit.

NOTICE:

Keeping the pre-installed o-ring (item **7** in **Figure 3**) may lead to water leakages, due to a possibly available extra ridge in the sealing surface of the - not type identical - pump housing.

NOTICE:

The standard pump units are not suitable for replacing WILO pump motors on WILO pump housings.

7 Troubleshooting

7.1 Precautions



WARNING:

Maintenance must be done by a technician possessing the technical-professional requirements outlined in the current regulations.



WARNING:

Observe the safety requirements in the chapters on **Use and Operation** and **Maintenance**.



WARNING:

If a fault cannot be corrected or is not mentioned, contact Xylem or the Authorised Distributor.

7.2 Error signals

The pump is equipped with self-diagnostics and malfunction detection. Defects detected by the pump system are signalled to the user with alternating short and long LED light flashes.

Operating mode / Error code	LED light status
Normal operation, the pump is running	Continuous on
Air purge sequence is active	Blinking 200 ms on - 200 ms off - 200 ms on...
Standby mode	Blinking 50 ms on - 1.5 s off - 50 ms on...
Low voltage failure	Blinking 1 x short - 1 x long...
Overtemperature failure	Blinking 3 x short - 1 x long...
Speed feedback failure	Blinking 4 x short - 1 x long...
Blocked rotor	Blinking 5 x short - 1 x long...

7.3 Pump not running

Cause	Remedy
Not connected or connected incorrectly	Connect correctly
Pump too hot, dry operation- or overheating protection active	Allow to cool, pump restarts automatically
Pump blocked	See section 6.3 Disassembly

7.4 Pump running for 1 minute periods only (temperature controlled models only)

Cause	Remedy
Water temperature signal is interrupted	Replace pump

7.5 Pump is noisy

Cause	Remedy
Not thoroughly air purged	See section 5.4 Air purge
Foreign objects in pump	See section 6.3 Disassembly
Worn bearing	Replace pump

8 Technical Information

8.1 Operating environment

Non-aggressive, non-explosive and frost-free atmosphere

Ambient temperature

Must be between 0 - 50 °C (32 - 122 °F)

Relative humidity of the air

Maximum 95 % at 50 °C (122 °F)

NOTICE:

In the event, that temperature and humidity exceed the indicated limits, contact Xylem or the Authorised Distributor.

NOTICE:

To avoid condensation in the stator or in the electronics, the liquid temperature must be higher than the ambient temperature.

8.2 Pumped liquid

NOTICE:

This circulator is suitable for drinking water only - EU Regulation No. 622/2012

For use with alternative circulating fluids (e.g. in special OEM applications) contact Xylem or the Authorised Distributor.

Temperature

The product meets the safety requirements of both the EN 60335-2-41 and the EN 60335-2-51 standards, so that in terms of product safety the allowed liquid temperature range is 5 - 95 °C (41 - 203 °F).

In case of circulating drinking water, the product is certified to maximum 85 °C (185 °F).

Water hardness

Maximum 68 °fH (38 °dH)

8.3 Electrical characteristics

Supply voltage

Without timer: 1~ 100 - 240 V ± 10 %; 50 / 60 Hz; PE

With timer: 1~ 230 V ± 10 %; 50 Hz; PE

Power consumption

3 - 9 W (1 m head versions)

3 - 27 W (3 m head versions)

For special OEM applications the maximum value is 40 W.

Insulation class

Class 155 (F)

Class of appliance

Class I

8.4 Mechanical characteristics

Ingress protection class

Without timer: IP 44

With timer: IP 42

Temperature class

TF95

Maximum working pressure

1 MPa (145 psi)

Sound pressure level

≤ 40 dB

8.5 Dimensions and weights

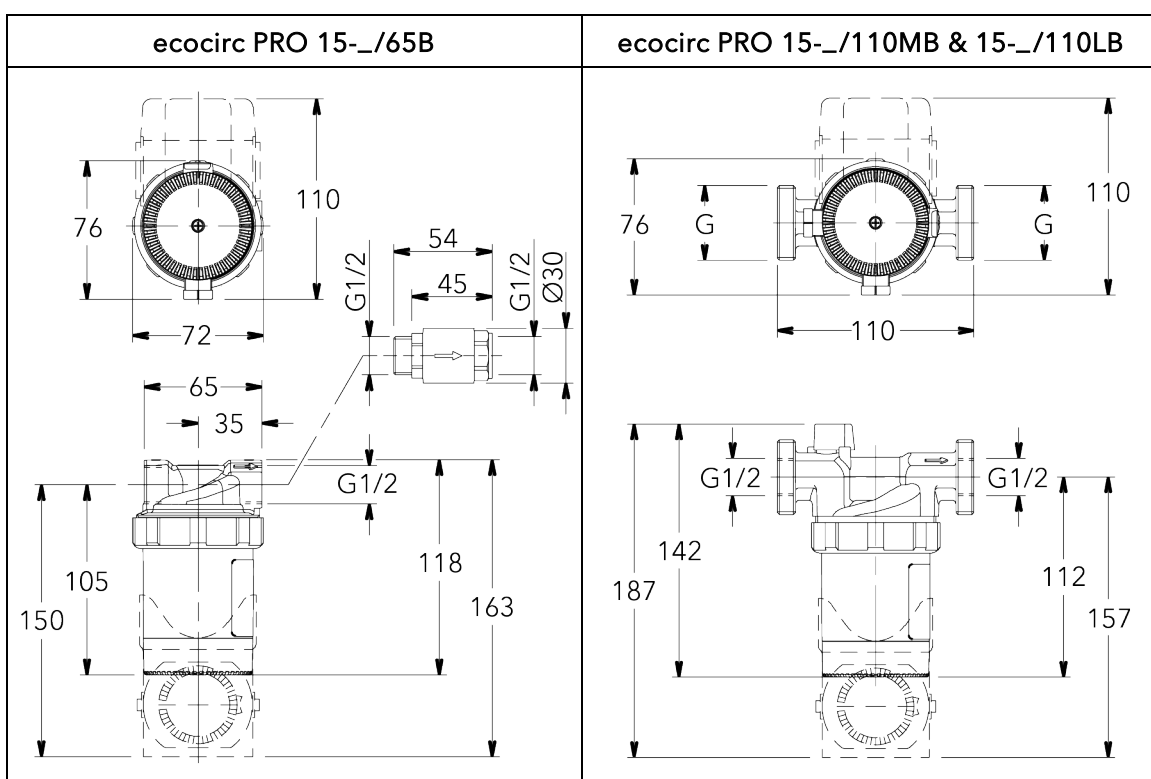
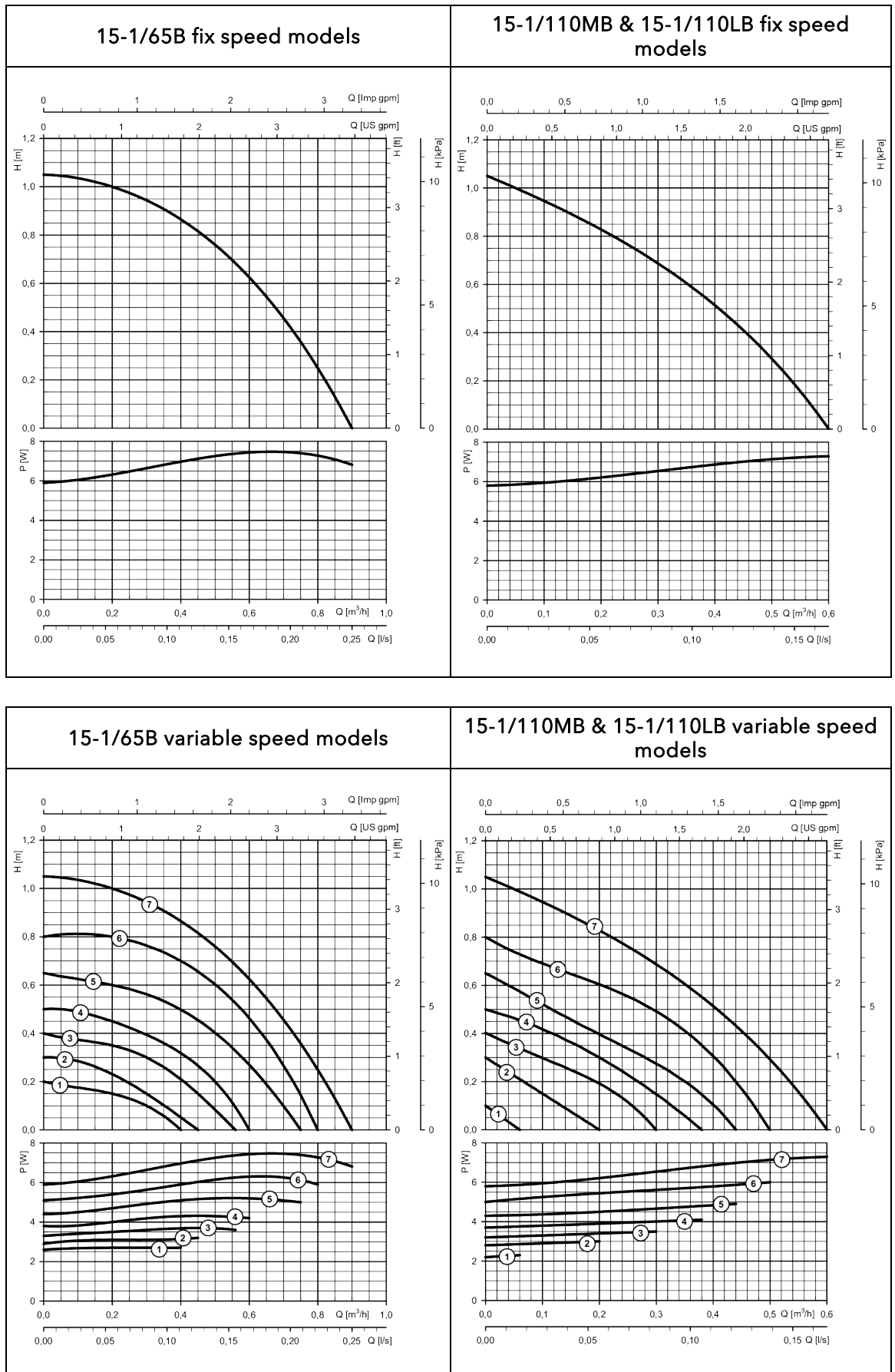
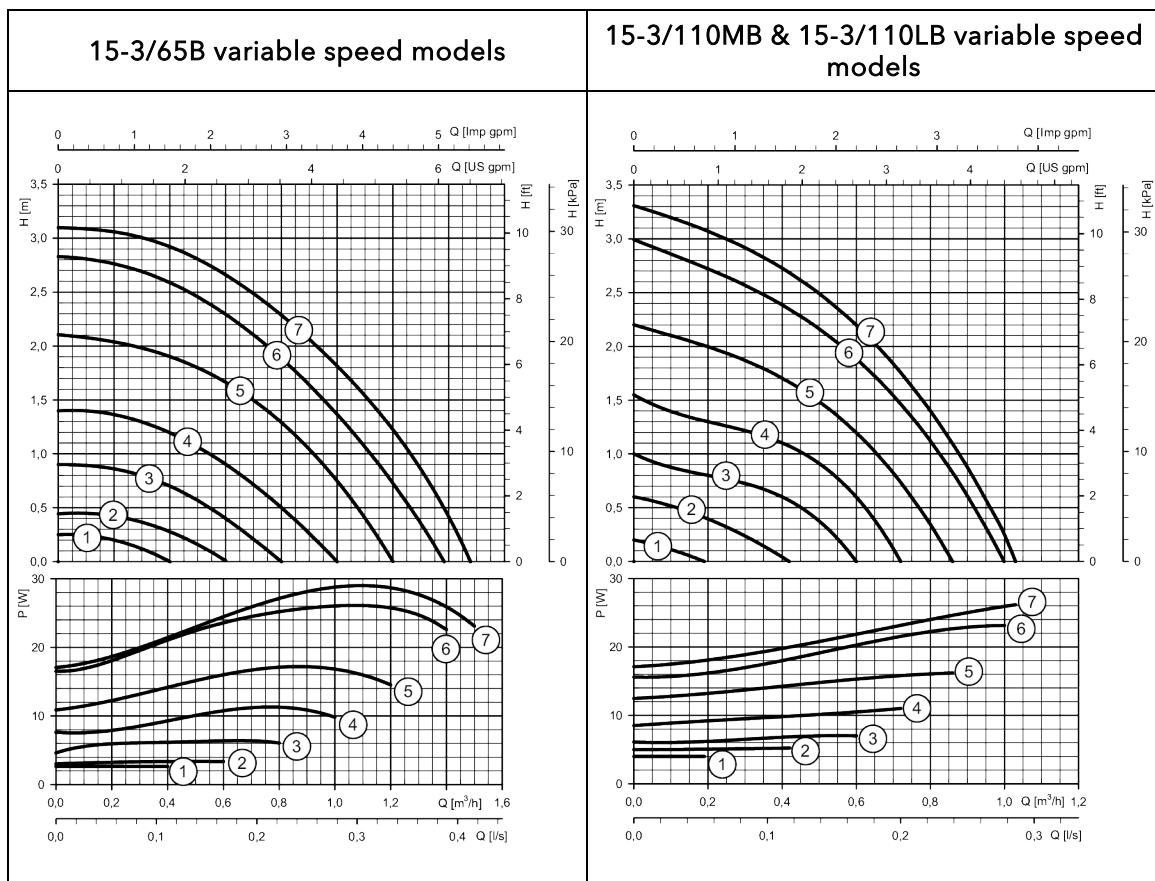

Figure 14

Model			G (in)	DN	Weight kg (lb)
15-1/65B	15-1/65B R	15-3/65B	-	15	0.9 (1.98)
15-1/65B U	15-1/65B RU		-	15	1.0 (2.20)
15-1/110MB	15-1/110MB R	15-3/110MB	G3/4	15	1.2 (2.65)
15-1/110MB U	15-1/110MB RU		G3/4	15	1.3 (2.87)
15-1/110LB	15-1/110LB R	15-3/110LB	G1 1/4	15	1.3 (2.87)
15-1/110LB U	15-1/110LB RU		G1 1/4	15	1.4 (3.09)

8.6 Hydraulic curves





8.7 OEM models

For special OEM (Original Equipment Manufacturer) applications the pump has customized versions, which differ from the standard trade versions in some features. An individual PSS (Product Specification Sheet) document is issued for each of these versions including the hydraulic curve and the technical details highlighting the difference from the standard versions.

9 Disposal

9.1 Precautions



WARNING:

The unit must be disposed of through approved companies specialised in the identification of different types of materials (steel, copper, plastic, etc.).



WARNING:

It is prohibited to dispose of lubricating fluids and other hazardous substances in the environment.

Recycling guidelines

Always follow local laws and regulations regarding recycling.

9.2 WEEE (50 Hz)

INFORMATION TO USERS pursuant to art. 14 of the Directive 2012/19/EU of the European Parliament and of the Council of 4 July 2012 on waste electrical and electronic equipment (WEEE).



The crossed bin symbol on the appliance or on its packaging indicates that the product at the end of its useful life must be collected separately and not disposed of together with other mixed urban waste.

Appropriate separate collection for the subsequent start-up of the disused equipment for recycling, treatment and environmentally compatible disposal helps to avoid possible negative effects on the environment and on health and favors the re-use and / or recycling of the materials it is composed of the equipment.

WEEE from private households: Please contact your municipality, or local authority, for all information regarding the separate collection systems available in the area. The retailer is obliged to collect the old equipment free of charge when buying new equipment of an equivalent type, for the purpose of starting the correct recycling / disposal.

WEEE other than WEEE from private households: The separate collection of this equipment at the end of its life is organized and managed by the producer. The user who wants to get rid of this equipment can then contact the producer and follow the system that it has adopted to allow the separate collection of equipment at the end of life, or select a supply chain independently authorized to manage.

10 EU Declaration of Conformity

1. Apparatus model/Product:
See the label on the Safety Instructions and Quick Start-up Guide
2. Name and address of the manufacturer:
Xylem Service Hungary Kft.
Külső-Kátai út 41.
2700 Cegléd - Hungary
3. This declaration of conformity is issued under the sole responsibility of the manufacturer.
4. Object of the declaration:
Circulation pump
5. The object of the declaration described above is in conformity with the relevant Union harmonization legislation:
Low Voltage Directive 2014/35/EU
Electromagnetic Compatibility (EMC) Directive 2014/30/EU
Eco-design Directive 2009/125/EC and Regulations (EC) 641/2009 and (EU) 622/2012:
This circulator is suitable for drinking water only.
Restriction of Hazardous Substances (RoHS II) Directive 2011/65/EU and (EU) 2015/863
6. References to the relevant harmonized standards used or references to the other technical specifications, in relation to which conformity is declared:
EN 60335-1:2012+A11:2014+A13:2017
EN 60335-2-41:2003+A1:2004+A2:2010
EN 60335-2-51:2003+A1:2008+A2:2012
EN 55014-1:2017
EN 55014-2:2015
EN 61000-3-2:2014
EN 61000-3-3:2013
EN 61000-6-2:2007
EN 61000-6-3:2007+A1:2011
7. Notified body:
-
8. Additional information:
-

Cegléd, 18. 12. 2019.



Amedeo Valente
Director of Engineering and R&D

11 Warranty

11.1 Information

For information on the warranty refer to the documentation of the sale contract.

Xylem |'zīləm|

- 1) The tissue in plants that brings water upward from the roots;
- 2) A leading global water technology company.

We're a global team unified in a common purpose: creating innovative solutions to meet our world's water needs. Developing new technologies that will improve the way water is used, conserved, and re-used in the future is central to our work. We move, treat, analyze, and return water to the environment, and we help people use water efficiently, in their homes, buildings, factories and farms. In more than 150 countries, we have strong, long-standing relationships with customers who know us for our powerful combination of leading product brands and applications expertise, backed by a legacy of innovation.

For more information on how Xylem can help you, go to www.xylem.com



Xylem Service Hungary Kft.
Külső-Kátai út 41.
2700 Cegléd - Hungary
www.xylem.com/brands/lowara

Lowara is a trademark of Xylem Inc. or one of its subsidiaries.