

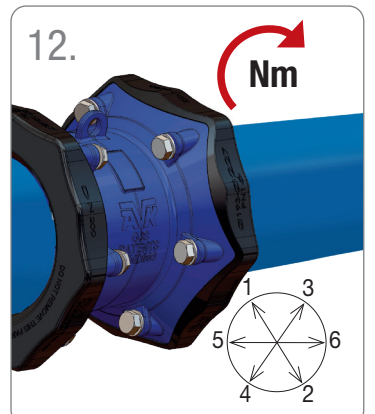

AVK SUPA MAXI™

Asennusohje

SARJA 631/632/633/634/635

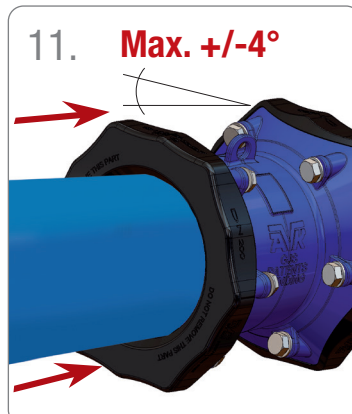
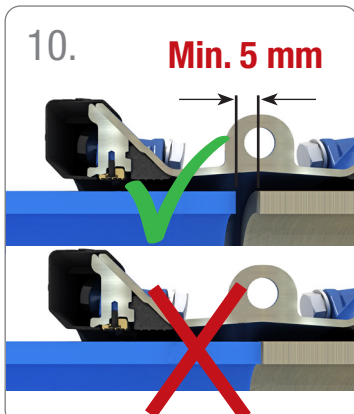
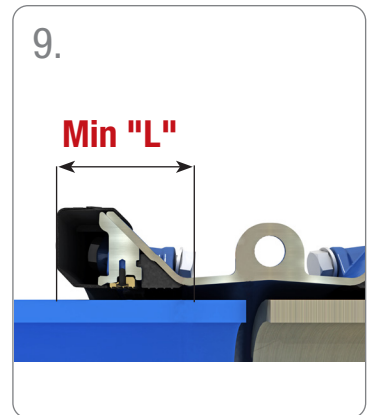
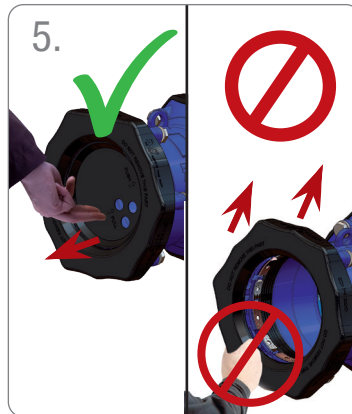
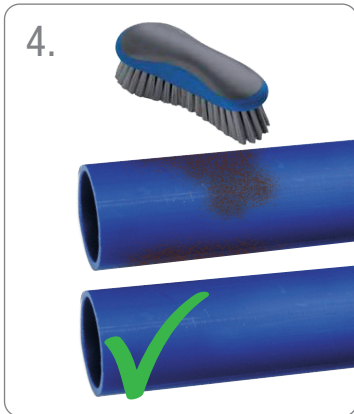
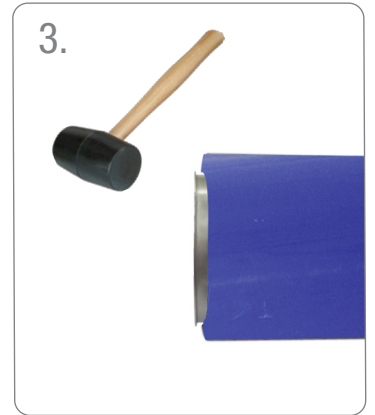
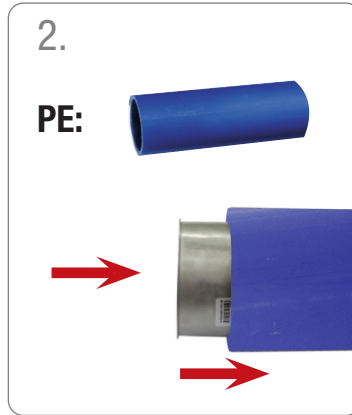

Asennusohje

AVK Supa Maxi™ sarja 631/632/633/634/635



TARKISTA!



www.avkfinland.fi

Tärkeää: Jos liitin on asennettu teräs/valurauta/asbestisementtiputkille ensin ja se halutaan jälleenasentaa PE- tai PVC-putkelle, on punametalliset (gunmetal) tartuntaosat (joka toinen) vaihdettava ensin.

Erillinen asennusohje tartuntaosien vaihtoon.

Pulttien min. kiristysmomentti ja putkien min. asennussyvyys ("L")

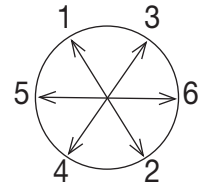

DN	Toleranssi mm	Pultit kpl x koko x pituus	Nm Rauta/Teräs*) PN 10 / PN 16	Nm PE/PVC PN 10 / PN 16	Nm Asbestisementti Max. PN 10	"L" min. mm
50	48-71	3 x M14 x 75 mm	60	60	50	90
65	69-91	3 x M16 x 75 mm	60	60	50	90
80	82-106	3 x M16 x 75 mm	80	80	60	90
100	104-133	4 x M16 x 75 mm	80	80	60	90
125	132-161	4 x M16 x 75 mm	100	100	80	90
150	159-188	4 x M16 x 90 mm	100	100	80	100
200	193-227	6 x M20 x 100 mm	120	120	90	120
225	224-257	6 x M20 x 100 mm	120	120	90	120
250	266-301	6 x M20 x 100 mm	140	140	110	120
300	314-356	8 x M20 x 110 mm	140	140	110	120
400	392-442	10 x M24 x 120 mm	220	220	130	145
450	448-510	12 x M24 x 120 mm	220	220	130	160
500	498-552	14 x M24 x 120 mm	220	220	130	160
600	604-652	18 x M24 x 130 mm	220	220	130	160

Expect...