

Concrete screw UltraCut FBS II 6

The high-performance concrete screw for absolute installation ease.

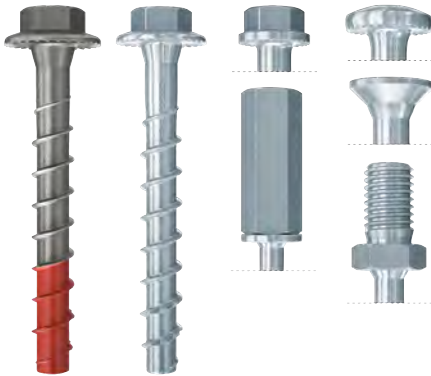

Suspended air-conditioners



Fastenings in outdoor areas with FBS II 6 R

4

Applications

- Pipeline routes
- Suspension for individual pipes
- Suspended mounting rails
- Prestressed concrete hollow core ceilings
- Cable trays
- Ventilation ducts
- Perforated tapes
- Air conditioning units

Advantages

- The European Technical Approval (ETA) Option 1 includes the use in cracked and non-cracked concrete for highest safety requirements.
- The UltraCut FBS II 6 is approved for multiple use of non-load bearing systems and thereby ideal for the installation of pipe routes and prestressed hollow concrete ceilings.
- The FBS II 6 also has an ETA for seismic performance category C1 for additional safety standards.
- The Fischer concrete screw FBS II 6 zinc-

- plated offer the possibility for the ETA compliant application in masonry brick. This grants high security not only in concrete but also in solid clay bricks (ENtt1-1), sand-lime bricks KSL (EN711-2) and solid sand-lime bricks KSV (EN771-2).
- The expansion-free anchorage (undercut) ensures low edge and axial spacings.
- The stainless steel concrete screw guarantees a high level of corrosion resistance especially for wet rooms and external applications.

Certificates / Features



ETA-18/0242, for use in concrete for redundant non-structural systems
 ETA-20/0134, in masonry
 ETA-15/0352, in cracked concrete
 ETA-17/0740 in cracked concrete
 ETA-24/0973 for use in concrete for redundant non-structural systems



Building materials

Approved for:

- Concrete C20/25 to C50/60, cracked and non-cracked
- Prestressed hollow concrete ceilings C30/37 to C50/60 for the multiple use of non-load bearing systems
- Masonry brick (EN771-1), solid sand-lime brick (EN771-2) and perforated sand-lime brick (EN771-2)

Also suitable for:

- Concrete C12/15
- Solid building materials
- Masonry with dense structure

Versions

- Galvanised steel
- Stainless steel

Functioning

- The UltraCut FBS II is recommended for the push-through / pre-positioned installation.
- Drill holes do not need to be cleaned during vertical installation (ceiling and floor) with the FBS II 6 zinc-plated. For floor fixings the hole must be drilled 3x drill hole diameter deeper.
- The approved adjustment for the concrete screws allows the screw to be unscrewed twice for a total length of 20 mm, to place maximum 10 mm packing below the base plates or to align the attached part, and then to tighten the screw again.
- The screw is installed correctly when the screw head sits flush on the fixture (visual setting control).
- We recommend using a Fischer impact wrench FSS 18V with a suitable impact screwdriver socket or an internal torx drive.

Installation UltraCut FBS II 6 in concrete

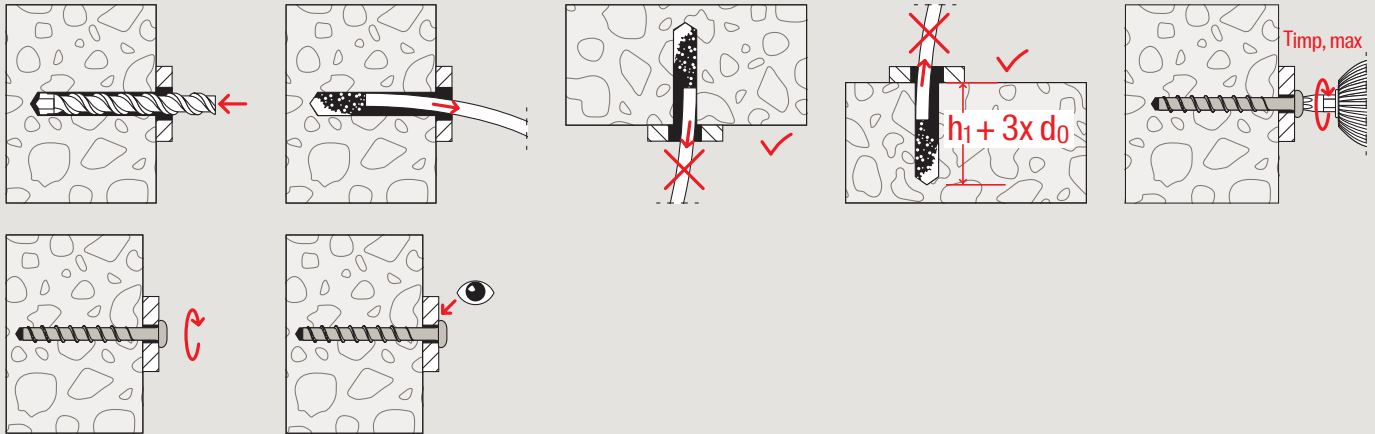

Fixture adjustment UltraCut FBS II 6

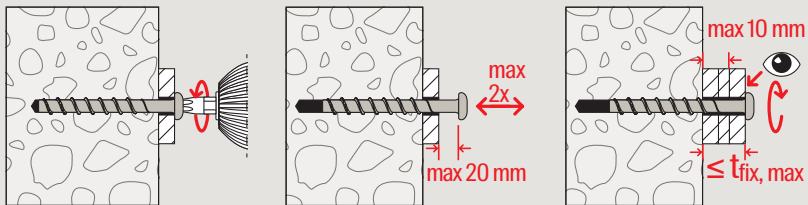

Additional for seismic applications

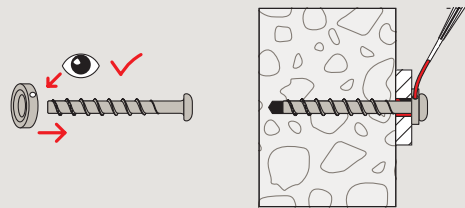

Installation UltraCut FBS II 6 R in concrete

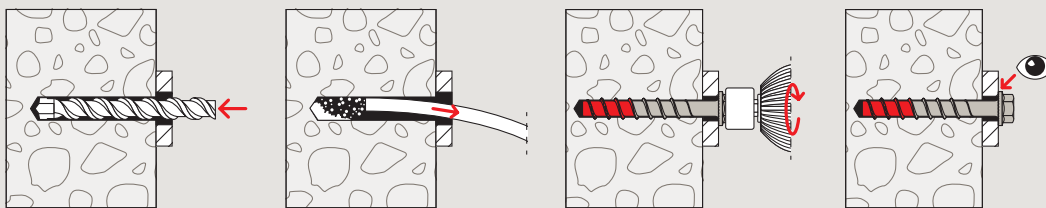

Fixture adjustment UltraCut FBS II 6 R

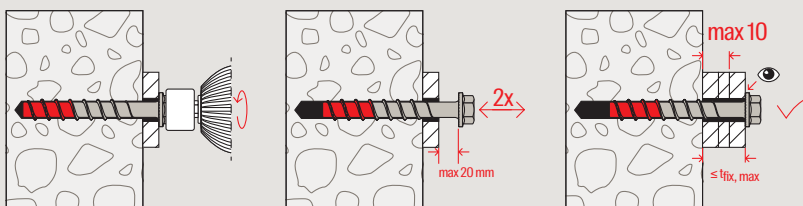

Installation UltraCut FBS II gvz in masonry

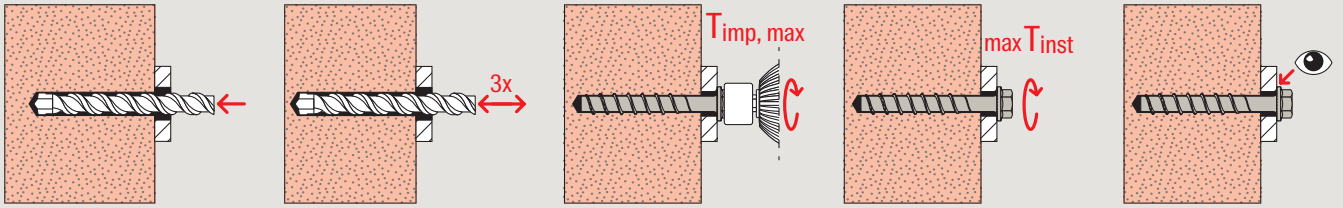

Fixture adjustment UltraCut FBS II gvz

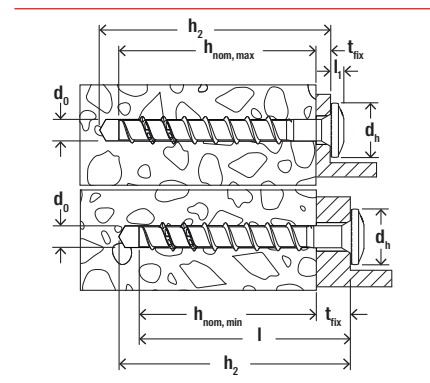
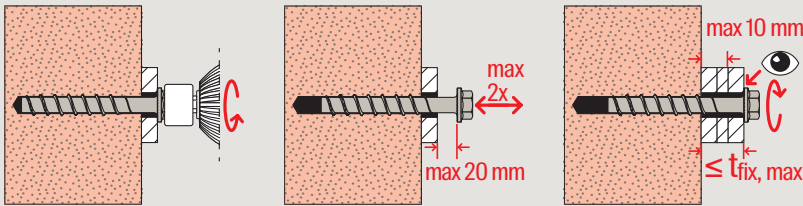

Technical data

Concrete screw UltraCut FBS II 6



UltraCut FBS II 6 P / FBS II 6 LP

UltraCut FBS II 6 SK

UltraCut FBS II 6 US

Item	Item no.	Approval ETA	Drill diameter d ₀ [mm]	Min. drill hole depth for through fixings h ₂ [mm]	Screw length l _s [mm]	Head-ø d _h [mm]	Screw-in depth Multiple fixing ETA h _{nom,min} - h _{nom,max} [mm]	Screw-in depth Single point fixing ETA h _{nom,min} - h _{nom,max} [mm]	Usable length t _{fix,min} - t _{fix,max} [mm]	Drive	Sales unit [pcs]
FBS II 6 x 30/5 P	546377 ¹⁾	●	6	40	30	14.4	25	-	Screw length - h _{nom}	TX30	100
FBS II 6 x 40/5 P	546378 ¹⁾	●	6	50	40	14.4	25-35	-	Screw length - h _{nom}	TX30	100
FBS II 6 x 40/5 LP	546379 ¹⁾	●	6	50	40	17.5	25-35	-	Screw length - h _{nom}	TX30	100
FBS II 6 x 60/5 P	546380 ²⁾	●	6	70	60	14.4	25-55	40-55	Screw length - h _{nom}	TX30	100
FBS II 6 x 80/25 P	546381 ²⁾	●	6	90	80	14.4	25-55	40-55	Screw length - h _{nom}	TX30	100
FBS II 6 x 30/5 SK	546382 ¹⁾	●	6	40	30	13.5	25	-	Screw length - h _{nom}	TX30	100
FBS II 6 x 40/5 SK	546383 ¹⁾	●	6	50	40	13.5	25-35	-	Screw length - h _{nom}	TX30	100
FBS II 6 x 60/5 SK	546384 ²⁾	●	6	70	60	13.5	25-55	40-55	Screw length - h _{nom}	TX30	100
FBS II 6 x 80/25 SK	546385 ²⁾	●	6	90	80	13.5	25-55	40-55	Screw length - h _{nom}	TX30	100
FBS II 6 x 100/45 SK	546386 ²⁾	●	6	110	100	13.5	25-55	40-55	Screw length - h _{nom}	TX30	100
FBS II 6 x 120/65 SK	546387 ²⁾	●	6	130	120	13.5	25-55	40-55	Screw length - h _{nom}	TX30	100
FBS II 6 x 140/85 SK	546388 ²⁾	●	6	150	140	13.5	25-55	40-55	Screw length - h _{nom}	TX30	100

¹⁾ Values for screw-in depth according to ETA-18/0242 for multiple fixings.

²⁾ Values for screw-in depth according to ETA-15/0352 for single-point fixings and ETA-18/0242 for multiple fixings.

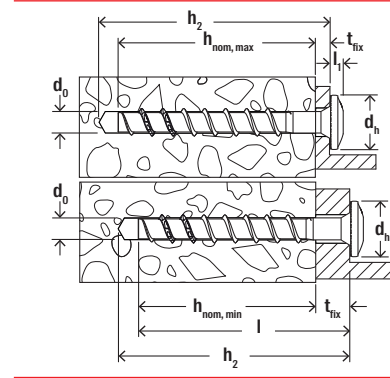

Technical data

Concrete screw UltraCut FBS II 6



UltraCut FBS II 6 P / FBS II 6 LP UltraCut FBS II 6 SK UltraCut FBS II 6 US

Item	Item no.	Approval ETA	Drill diameter	Min. drill hole depth for through fixings	Screw length	Head-ø	Screw-in depth Multiple fixing ETA	Screw-in depth Single point fixing ETA	Usable length	Drive	Sales unit [pcs]
			d_0 [mm]	h_2 [mm]	l_s [mm]	d_h [mm]	$h_{nom,min} - h_{nom,max}$ [mm]	$h_{nom,min} - h_{nom,max}$ [mm]	$t_{fix,min} - t_{fix,max}$ [mm]		
FBS II 6 x 160/105 SK	546389 ²⁾	●	6	170	160	13.5	25-55	40-55	Screw length - h_{nom}	TX30	100
FBS II 6 x 40/5 US	558601 ¹⁾	●	6	50	40	17	25-35	-	Screw length - h_{nom}	SW 13	100
FBS II 6 x 40/5 US	546390 ¹⁾	●	6	50	40	17	25-35	-	Screw length - h_{nom}	SW 10	100
FBS II 6 x 60/5 US	558602 ²⁾	●	6	70	60	17	25-55	40-55	Screw length - h_{nom}	SW 13	100
FBS II 6 x 60/5 US	546391 ²⁾	●	6	70	60	17	25-55	40-55	Screw length - h_{nom}	SW 10	100
FBS II 6 x 80/25 US	558603 ²⁾	●	6	90	80	17	25-55	40-55	Screw length - h_{nom}	SW 13	100
FBS II 6 x 80/25 US	546392 ²⁾	●	6	90	80	17	25-55	40-55	Screw length - h_{nom}	SW 10	100
FBS II 6 x 100/45 US	558604 ²⁾	●	6	110	100	17	25-55	40-55	Screw length - h_{nom}	SW 13	100
FBS II 6 x 100/45 US	546393 ²⁾	●	6	110	100	17	25-55	40-55	Screw length - h_{nom}	SW 10	100
FBS II 6 x 120/65 US	558605	●	6	130	120	17	25 - 55	40 - 55	Screw length - h_{nom}	SW 13	100
FBS II 6 x 120/65 US	546394	●	6	130	120	17	25 - 55	40 - 55	Screw length - h_{nom}	SW 10	100

¹⁾ Values for screw-in depth according to ETA-18/0242 for multiple fixings.
²⁾ Values for screw-in depth according to ETA-15/0352 for single-point fixings and ETA-18/0242 for multiple fixings.

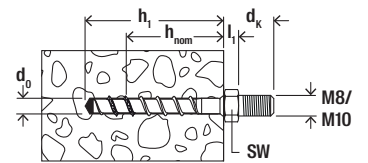
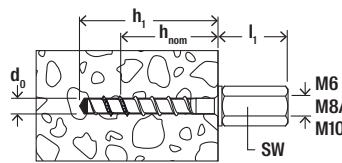

Technical data

Concrete screw UltraCut FBS II 6 M8/M10



UltraCut FBS II M8/M10

UltraCut FBS II M6

Item	Item no.	Approval ETA	Drill diameter d_0 [mm]	Min. drill hole depth for pre-positioned installation h_1 [mm]	Screw diameter d_s [mm]	Screw length l_s [mm]	Screw-in depth Multiple fixing ETA		Screw-in depth Single point fixing ETA		Drive	Sales unit [pcs]
							$h_{nom,min}$ - $h_{nom,max}$ [mm]	$h_{nom,min}$ - $h_{nom,max}$ [mm]				
FBS II 6 x 25 M8/19	546395 ¹⁾	●	6	35	6.0	25	25	-	-	SW 10	100	
FBS II 6 x 35 M8/19	546396 ¹⁾	●	6	45	6.0	35	35	-	-	SW 10	100	
FBS II 6 x 55 M8/19	546397 ²⁾	●	6	65	6.0	55	55	55	55	SW 10	100	
FBS II 6 x 35 M10/21	546398 ¹⁾	●	6	45	6.0	35	35	-	-	SW 13	100	
FBS II 6 x 55 M10/21	546399 ²⁾	●	6	65	6.0	55	55	55	55	SW 13	100	
FBS II 6x35 M6 I	554065 ¹⁾	●	6	45	6.0	35	35	-	-	SW 13	100	
FBS II 6x55 M6 I	554066 ²⁾	●	6	65	6.0	55	55	55	55	SW 13	100	
FBS II 6 x 35 M8/M10 I	546400 ¹⁾	●	6	45	6.0	35	35	-	-	SW 13	100	
FBS II 6 x 55 M8/M10 I	546401 ²⁾	●	6	65	6.0	55	55	55	55	SW 13	100	

¹⁾ Values for screw-in depth according to ETA-18/0242 for multiple fixings.

²⁾ Values for screw-in depth according to ETA-15/0352 for single-point fixings and ETA-18/0242 for multiple fixings.

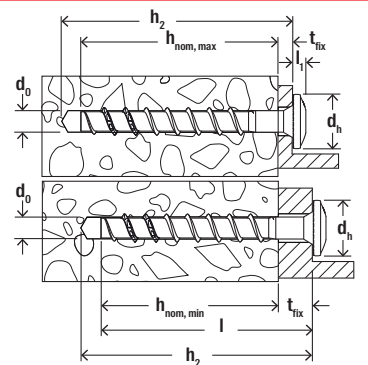

Technical data

Concrete screw UltraCut FBS II 6 R

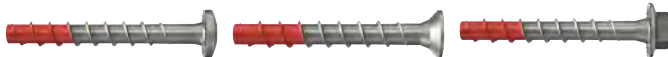

UltraCut FBS II P R

UltraCut FBS II SK R

UltraCut FBS II US R

Item	Item no.	Approval ETA	Drill diameter d_0 [mm]	Screw length l_s [mm]	Head- ϕ d_h [mm]	Screw-in depth Multiple fixing ETA		Screw-in depth Single point fixing ETA		Usable length $t_{fix,min}$ - $t_{fix,max}$ [mm]	Drive	Sales unit [pcs]
						$h_{nom,min}$ - $h_{nom,max}$ [mm]	$h_{nom,min}$ - $h_{nom,max}$ [mm]					
FBS II 6 x 50/5 P R	573429 ¹⁾	●	6	50	14	45	-	-	Screw length - h_{nom}	TX30	100	
FBS II 6 x 65/5 P R	573430 ²⁾	●	6	65	14	45 / 60	60	60	Screw length - h_{nom}	TX30	100	
FBS II 6 x 85/25 P R	573431 ²⁾	●	6	85	14	45 / 60	60	60	Screw length - h_{nom}	TX30	100	
FBS II 6 x 105/45 P R	573432 ²⁾	●	6	105	14	-	60	60	Screw length - h_{nom}	TX30	100	
FBS II 6 x 50/5 SK R	573420 ¹⁾	●	6	50	13.25	45	-	-	Screw length - h_{nom}	TX30	100	
FBS II 6 x 65/5 SK R	573421 ²⁾	●	6	65	13.25	45 / 60	60	60	Screw length - h_{nom}	TX30	100	
FBS II 6 x 85/5 SK R	573422 ²⁾	●	6	85	13.25	45 / 60	60	60	Screw length - h_{nom}	TX30	100	

¹⁾ Values for screw-in depth in accordance with ETA-24/0973 for multiple fixings.

²⁾ Values for screw-in depth in accordance with ETA-17/0740 for single-point fixings and ETA-24/0973 for multiple fixings.

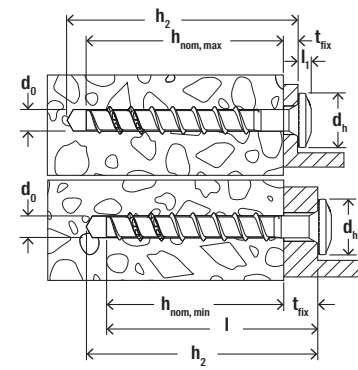

Technical data

Concrete screw UltraCut FBS II 6 R

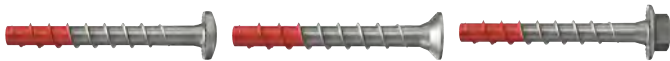

UltraCut FBS II P R UltraCut FBS II SK R UltraCut FBS II US R

Item	Item no.	Approval ETA	Drill diameter d ₀ [mm]	Screw length l _s [mm]	Head-ø d _h [mm]	Screw-in depth Multiple fixing ETA		Screw-in depth Single point fixing ETA		Usable length t _{fix,min} - t _{fix,max} [mm]	Drive	Sales unit [pcs]
						h _{nom,min}	h _{nom,max}	h _{nom,min}	h _{nom,max}			
FBS II 6 x 50/5 US R	573423 ¹⁾	●	6	50	17	45	-	-	-	Screw length - h _{nom}	SW 10	100
FBS II 6 x 50/5 US R	573426 ¹⁾	●	6	50	17	45	-	-	-	Screw length - h _{nom}	SW 13	100
FBS II 6 x 65/5 US R	573424 ²⁾	●	6	65	15	45 / 60	60	60	60	Screw length - h _{nom}	SW 10	100
FBS II 6 x 65/5 US R	573427 ²⁾	●	6	65	17	45 / 60	60	60	60	Screw length - h _{nom}	SW 13	100
FBS II 6 x 85/25 US R	573425 ²⁾	●	6	85	15	45 / 60	60	60	60	Screw length - h _{nom}	SW 10	100
FBS II 6 x 85/25 US R	573428 ²⁾	●	6	85	17	45 / 60	60	60	60	Screw length - h _{nom}	SW 13	100

¹⁾ Values for screw-in depth in accordance with ETA-24/0973 for multiple fixings.

²⁾ Values for screw-in depth in accordance with ETA-17/0740 for single-point fixings and ETA-24/0973 for multiple fixings.

Loads

Concrete screw UltraCut FBS II 6

Permissible loads of a single anchor¹⁾ in normal concrete of strength class C20/25.
For the design the complete current assessment ETA-15/0352 has to be considered.

Type	Material/ surface	Screw-in depth h _{nom} [mm]	Minimum member thickness h _{min} [mm]	Maximum installation torque T _{imp,max} ²⁾ [Nm]	Cracked concrete				Non-cracked concrete			
					Permissible tension (N _{perm}) and shear loads (V _{perm}); minimum spacing (s _{min}) and edge distances (c _{min}) with reduced loads				Permissible tension (N _{perm}) and shear loads (V _{perm}); minimum spacing (s _{min}) and edge distances (c _{min}) with reduced loads			
					N _{perm} ³⁾ [kN]	V _{perm} ³⁾ [kN]	s _{min} ³⁾ [mm]	c _{min} ³⁾ [mm]	N _{perm} ³⁾ [kN]	V _{perm} ³⁾ [kN]	s _{min} ³⁾ [mm]	c _{min} ³⁾ [mm]
FBS II 6	gvz	40	80	450	1.2	4.3	35	35	3.8	4.3	35	35
	gvz	45	90	450	1.7	4.3	35	35	4.8	4.3	35	35
	gvz	50	90	450	1.9	4.3	35	35	5.7	4.3	35	35
	gvz	55	100	450	2.4	6.3	35	35	6.4	6.3	35	35

¹⁾ Design according to EN 1992-4:2018 (for static resp. quasi-static loads). The partial safety factors for material resistance as regulated in the ETA as well as a partial safety factor for load actions of γ_L = 1.4 are considered. As a single anchor counts e.g. an anchor with a spacing s ≥ 3 x h_{ef} and an edge distance c ≥ 1.5 x h_{ef}. Accurate data see ETA.

²⁾ Maximum allowable torque for installation with any tangential impact screw driver. Further technical data see ETA.

³⁾ In the case of combinations of tension and shear loads, bending moments with reduced or minimum spacing and edge distances (anchor groups), the design must be carried out in accordance with the provisions of the complete ETA and the provisions of the EN 1992-4:2018. We recommend using our anchor design software C-FIX.

Loads

Concrete screw UltraCut FBS II 6

Permissible loads for a single anchor¹⁾ for multiple use of redundant non-structural applications* in normal concrete C20/25. For the design the complete current assessment ETA - 18/0242 has to be considered.

Type	Material/ surface	Screw-in depth h_{nom} [mm]	Minimum member thickness h_{min} [mm]	Maximum installation torque $T_{inst,max}^{2)}$ [Nm]	Cracked concrete				Non-cracked concrete			
					Permissible tension (N_{perm}) and shear loads (V_{perm}); minimum spacing (s_{min}) and edge distances (c_{min}) with reduced loads				Permissible tension (N_{perm}) and shear loads (V_{perm}); minimum spacing (s_{min}) and edge distances (c_{min}) with reduced loads			
					$N_{perm}^{3)}$ [kN]	$V_{perm}^{3)}$ [kN]	$s_{min}^{3)}$ [mm]	$c_{min}^{3)}$ [mm]	$N_{perm}^{3)}$ [kN]	$V_{perm}^{3)}$ [kN]	$s_{min}^{3)}$ [mm]	$c_{min}^{3)}$ [mm]
FBS II 6	gvz	25	80	≤ 5	0.7	1.8	35	35	1.4	2.3	35	35
	gvz	30	80	≤ 5	1.2	2.3	35	35	2.4	2.3	35	35
	gvz	35	80	≤ 5	1.7	4.3	35	35	3.1	4.3	35	35
	gvz	40	80	≤ 10	2.4	4.3	35	35	3.8	4.3	35	35
	gvz	45	90	≤ 10	2.9	4.3	35	35	4.8	4.3	35	35
	gvz	50	90	≤ 10	3.6	4.3	35	35	5.7	4.3	35	35
	gvz	55	100	≤ 10	4.0	6.3	35	35	6.4	6.3	35	35

* In addition to the load table above, the following must be considered for multiple fastening of non-structural redundant systems:

A multiple fixing (redundant system) according to EN 1992-4 and CEN/TR 17079 is defined by

- at least 3 fixing points (per attached element) with at least one anchor at each fixing point and a permissible load per fixing point of 1.4 kN
- or by at least 4 fixing points with at least one anchor each fixing point and a permissible load per fixing point of 2.1 kN

- Additionally, it has to be proven that the stiffness of the attached element shall be large enough to ensure that in case of excessive slip or failure of a fastener the load on this fastener or fixing point can be transferred to neighbouring fixing points without significantly violating the requirements on the attached element in the serviceability and ultimate limit state. For further details see EN 1992-4 section 7.3 and CEN/TR 17079.

¹⁾ Design according to EN 1992-4:2018 (for static resp. quasi-static loads). The partial safety factors for material resistance as regulated in the ETA as well as a partial safety factor for load actions of $\gamma_L = 1.4$ are considered.

²⁾ Further technical information for installation see ETA.

³⁾ In the case of combinations of tension and shear loads, bending moments with reduced or minimal edge and axial spacings (anchor groups), the design must be carried out in accordance with the provisions of the complete ETA and the provisions of the EN 1992-4:2018.

Loads

Concrete screw UltraCut FBS II 6

Permissible loads for a single anchor¹⁾ for multiple use of redundant non-structural applications* in pre-stressed hollow-core concrete slabs of concrete strength C30/37. For the design the complete current assessment ETA - 18/0242 has to be considered.

Type			FBS II 6 gvz						
Screw-in depth		h_{nom}	25	30	35	40	45	50	55
Permissible load $F_{perm}^{3)}$ in the respective bottom flange thickness									
$d_b \geq 25$ mm		[kN]	0.2	0.5	0.5	0.5	0.5	0.5	0.5
$d_b \geq 30$ mm		[kN]	1.7	1.7	1.7	1.7	1.7	1.7	1.7
$d_b \geq 35$ mm		[kN]	1.7	1.9	2.1	2.4	2.6	2.9	3.1
$d_b \geq 40$ mm		[kN]	1.7	2.3	2.6	2.9	3.3	3.6	3.8
$d_b \geq 50$ mm		[kN]	1.7	2.3	3.3	3.8	4.3	4.3	5.7
Installation torque	$T_{inst,max}$	[Nm]	5.0	5.0	10	10	10	10	10
Minimum spacing	$s_{t,s2}^{2)}$	[mm]	100	100	100	100	100	100	100
Minimum edge distance	$c_{t,c2}^{2)}$	[mm]	100	100	100	100	100	100	100

* In addition to the load table above, the following must be considered for multiple fastening of non-structural redundant systems:

A multiple fixing (redundant system) according to EN 1992-4 and CEN/TR 17079 is defined by

- at least 3 fixing points (per attached element) with at least one anchor at each fixing point and a permissible load per fixing point of 1.4 kN
- or by at least 4 fixing points with at least one anchor each fixing point and a permissible load per fixing point of 2.1 kN

- Additionally, it has to be proven that the stiffness of the attached element shall be large enough to ensure that in case of excessive slip or failure of a fastener the load on this fastener or fixing point can be transferred to neighbouring fixing points without significantly violating the requirements on the attached element in the serviceability and ultimate limit state. For further details see EN 1992-4 section 7.3 and CEN/TR 17079.

¹⁾ Design according to EN 1992-4:2018 (for static resp. quasi-static loads). The partial safety factors for material resistance as regulated in the ETA as well as a partial safety factor for load actions of $\gamma_L = 1.4$ are considered.

²⁾ Further technical information for installation see ETA.

³⁾ Valid for tensile load, shear load and oblique load under any angle. In the case of combinations of tensile, shear loads and bending moments, the design must be carried out in accordance with the provisions of the complete ETA and the provisions of the EN 1992-4:2018.

Loads

Concrete screw UltraCut FBS II US/SK

Permissible loads^{1,2)} for a single anchor in masonry for Push-through installation.
For the design the complete current assessment ETA-20/0134 of 14.07.2022 has to be considered.

Type	Min. compressive brick strength f_b [N/mm ²]	Brick raw density ρ [kg/dm ³]	Minimum brick dimensions (L x W x H) [mm]	Nominal anchorage depth h_{nom} [mm]	Minimum member thickness h_{min} [mm]	Maximum Installation torque $T_{imp,max}^{3)}$ [Nm]	Permissible tensile load ⁴⁾ N_{perm} [kN]	Permissible shear load ⁴⁾ parallel ⁶⁾ $V_{perm \parallel}$ [kN]	Minimum spacing ⁵⁾ $s_{min \parallel} / s_{min \perp}$ [mm]	Minimum edge distance ⁵⁾ c_{min} [mm]
Solid brick Mz, acc. to EN 771-1										
FBS II 6	≥ 12.0	≥ 1.8	240 x 115 x 71	≥ 40	≥ 115	80	0.54	0.34	80	50
FBS II 6	≥ 16.0	≥ 1.8	240 x 115 x 71	≥ 40	≥ 115	80	0.60	0.40	80	50
FBS II 6	≥ 17.5	≥ 1.8	240 x 115 x 71	≥ 40	≥ 115	80	0.66	0.40	80	50
FBS II 8	≥ 12.0	≥ 1.8	240 x 115 x 71	≥ 50	≥ 115	80	0.46	1.37	80	60
FBS II 8	≥ 16.0	≥ 1.8	240 x 115 x 71	≥ 50	≥ 115	80	0.54	1.60	80	60
FBS II 8	≥ 17.5	≥ 1.8	240 x 115 x 71	≥ 50	≥ 115	80	0.57	1.66	80	60
FBS II 10	≥ 12.0	≥ 1.8	240 x 115 x 71	≥ 55	≥ 115	80	0.40	1.26	80	70
FBS II 10	≥ 16.0	≥ 1.8	240 x 115 x 71	≥ 55	≥ 115	80	0.46	1.46	80	70
FBS II 10	≥ 17.5	≥ 1.8	240 x 115 x 71	≥ 55	≥ 115	80	0.49	1.51	80	70
Solid brick Mz, nordic, acc. to EN 771-1										
FBS II 6	≥ 16.0	≥ 1.8	228 x 108 x 54	≥ 40	≥ 108	80	0.34	0.31	80	50
FBS II 6	≥ 20.0	≥ 1.8	228 x 108 x 54	≥ 40	≥ 108	80	0.40	0.37	80	50
FBS II 8	≥ 16.0	≥ 1.8	228 x 108 x 54	≥ 50	≥ 108	80	0.46	1.34	80	60
FBS II 8	≥ 20.0	≥ 1.8	228 x 108 x 54	≥ 50	≥ 108	80	0.51	1.49	80	60
FBS II 10	≥ 16.0	≥ 1.8	228 x 108 x 54	≥ 55	≥ 108	80	0.37	1.23	80	70
FBS II 10	≥ 20.0	≥ 1.8	228 x 108 x 54	≥ 55	≥ 108	80	0.43	1.37	80	70
Solid sand-lime brick KS, acc. to EN 771-2										
FBS II 6	≥ 12.0	≥ 1.8	240 x 115 x 71	≥ 40	≥ 115	80	0.43	0.51	80	50
FBS II 6	≥ 16.0	≥ 1.8	240 x 115 x 71	≥ 40	≥ 115	80	0.49	0.60	80	50
FBS II 6	≥ 20.0	≥ 1.8	240 x 115 x 71	≥ 40	≥ 115	80	0.54	0.66	80	50
FBS II 8	≥ 12.0	≥ 1.8	240 x 115 x 71	≥ 50	≥ 115	80	0.54	0.66	80	60
FBS II 8	≥ 16.0	≥ 1.8	240 x 115 x 71	≥ 50	≥ 115	80	0.60	0.74	80	60
FBS II 8	≥ 20.0	≥ 1.8	240 x 115 x 71	≥ 50	≥ 115	80	0.69	0.83	80	60
FBS II 10	≥ 12.0	≥ 1.8	240 x 115 x 71	≥ 55	≥ 115	80	0.54	0.89	80	70
FBS II 10	≥ 16.0	≥ 1.8	240 x 115 x 71	≥ 55	≥ 115	80	0.63	1.00	80	70
FBS II 10	≥ 20.0	≥ 1.8	240 x 115 x 71	≥ 55	≥ 115	80	0.69	1.11	80	70
Perforated sand-lime brick KSL, acc. to EN 771-2										
FBS II 6	≥ 10.0	≥ 1.4	240 x 175 x 113	≥ 40	≥ 175	65	0.09	0.80	80	50
FBS II 6	≥ 12.0	≥ 1.4	240 x 175 x 113	≥ 40	≥ 175	65	0.11	0.94	80	50
FBS II 6	≥ 16.0	≥ 1.4	240 x 175 x 113	≥ 40	≥ 175	65	0.14	1.17	80	50
FBS II 6	≥ 17.5	≥ 1.4	240 x 175 x 113	≥ 40	≥ 175	65	0.17	1.26	80	50
FBS II 8	≥ 10.0	≥ 1.4	240 x 175 x 113	≥ 50	≥ 175	65	0.26	0.66	80	60
FBS II 8	≥ 12.0	≥ 1.4	240 x 175 x 113	≥ 50	≥ 175	65	0.29	1.03	80	60
FBS II 8	≥ 16.0	≥ 1.4	240 x 175 x 113	≥ 50	≥ 175	65	0.37	1.40	80	60
FBS II 8	≥ 17.5	≥ 1.4	240 x 175 x 113	≥ 50	≥ 175	65	0.40	1.49	80	60
FBS II 10	≥ 10.0	≥ 1.4	240 x 175 x 113	≥ 55	≥ 175	65	0.23	0.77	80	70
FBS II 10	≥ 12.0	≥ 1.4	240 x 175 x 113	≥ 55	≥ 175	65	0.26	1.23	80	70
FBS II 10	≥ 16.0	≥ 1.4	240 x 175 x 113	≥ 55	≥ 175	65	0.34	1.66	80	70
FBS II 10	≥ 17.5	≥ 1.4	240 x 175 x 113	≥ 55	≥ 175	65	0.37	1.77	80	70

¹⁾ The partial safety factors for material resistance as regulated in assessment as well as a partial safety factor for load actions of $\gamma_L = 1.4$ are considered. Load values are valid for zinc-plated steel all sizes and head shapes, for stainless steel R for the sizes 8 and 10. Exakt values see ETA.

²⁾ The given loads are valid for installation and use of fixations in dry masonry, use category d/d, width of the joints $w_j \leq 3$ mm and general purpose mortar with strength class M2.5 -M9. Further information and details on drill hole preparation, etc., see ETA.

³⁾ Maximum allowable device torque for installation with any tangential impact screw driver. Further technical data see ETA.

⁴⁾ In the case of combinations of tensile and shear loads, bending moments and reduced edge and axial spacings (anchor groups), the design must be carried out in accordance with the provisions of the complete assessment.

⁵⁾ Minimum feasible spacing resp. edge distance. Details as well as to the distances to joints see assessment.

⁶⁾ Shear load parallel to the vertical joint. Load reduction for shear load perpendicular to the vertical joint see ETA.