

**SCHEME: K**

Name : \_\_\_\_\_  
Roll No. : \_\_\_\_\_ Year : 20\_\_ 20\_\_  
Exam Seat No. : \_\_\_\_\_

# LABORATORY MANUAL FOR BASICS OF MECHATRONICS (314017)



**MECHANICAL ENGINEERING GROUP**



**MAHARASHTRA STATE BOARD OF  
TECHNICAL EDUCATION, MUMBAI  
(Autonomous) (ISO 9001: 2015) (ISO/IEC 27001:2013)**

## **Vision**

To ensure that the Diploma level technical education constantly matches the latest requirements of Technology and industry and includes the all-round personal development of students including social concerns and to become globally competitive, technology led organization.

## **Mission**

To provide high quality technical and managerial manpower, information and consultancy services to the industry and community to enable the industry and community to face the challenging technological & environmental challenges.

## **Quality Policy**

We, at MSBTE are committed to offer the best in class academic services to the students and institutes to enhance the delight of industry and society. This will be achieved through continual improvement in management practices adopted in the process of curriculum design, development, implementation, evaluation and monitoring system along with adequate faculty development programmes.

## **Core Values**

**MSBTE believes in the following:**

- Skill development in line with industry requirements.
- Industry readiness and improved employability of Diploma holders.
- Synergistic relationship with industry.
- Collective and Cooperative development of all stake holders.
- Technological interventions in societal development.
- Access to uniform quality technical education.

**MSBTE believes in the following:**

- Skill development in line with industry requirements.
- Industry readiness and improved employability of Diploma holders.
- Synergistic relationship with industry.
- Collective and Cooperative development of all stake holders.
- Technological interventions in societal development.
- Access to uniform quality technical education.

**A Practical Manual for**  
**BASICS OF MECHATRONICS**  
**(314017)**

**Semester– (IV)**

**“K- SCHEME”**

**Diploma in Mechanical Engineering**

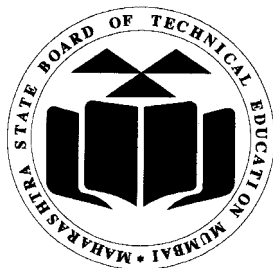

**Maharashtra State**  
**Board of Technical Education, Mumbai**  
**(Autonomous) (ISO-9001-2015) (ISO/IEC 27001:2013)**

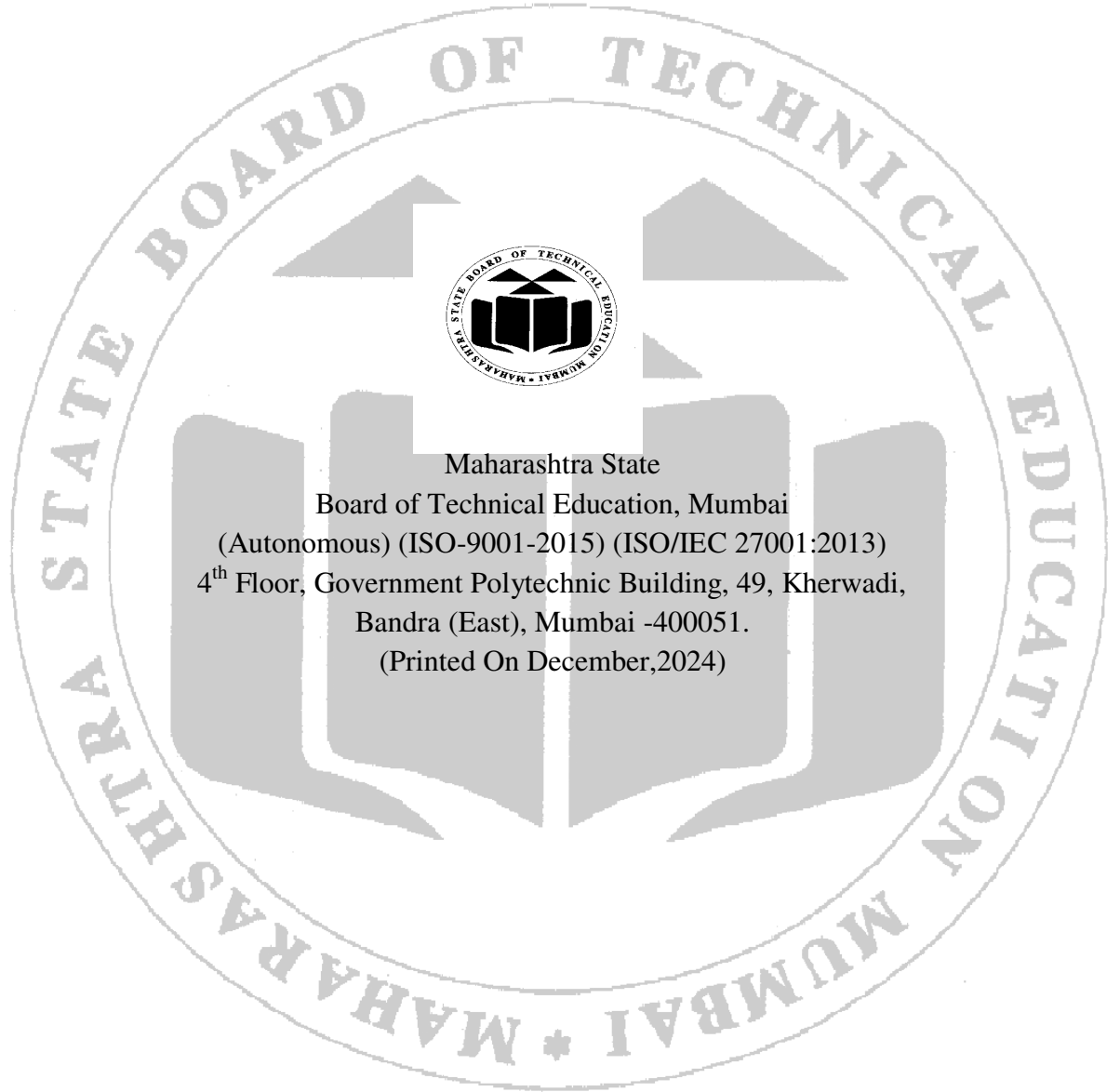

Maharashtra State  
Board of Technical Education, Mumbai  
(Autonomous) (ISO-9001-2015) (ISO/IEC 27001:2013)  
4<sup>th</sup> Floor, Government Polytechnic Building, 49, Kherwadi,  
Bandra (East), Mumbai -400051.  
(Printed On December,2024)



**Maharashtra State  
Board of Technical Education, Mumbai**

**Certificate**

This is to certify that Mr. / Ms. .... Roll  
No..... of Fourth Semester of Diploma in  
..... of Institute  
.....

(Code..... ) has completed the term work satisfactorily in course **BASICS  
OF MECHATRONICS (314017)** for the academic year 20.....to 20..... as  
prescribed in the curriculum.

Place: .....

Enrollment No.....

Date: .....

Exam Seat No. ....

**Course Teacher**

**Head of the Department**

**Principal**

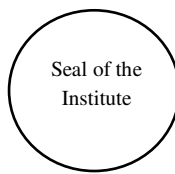

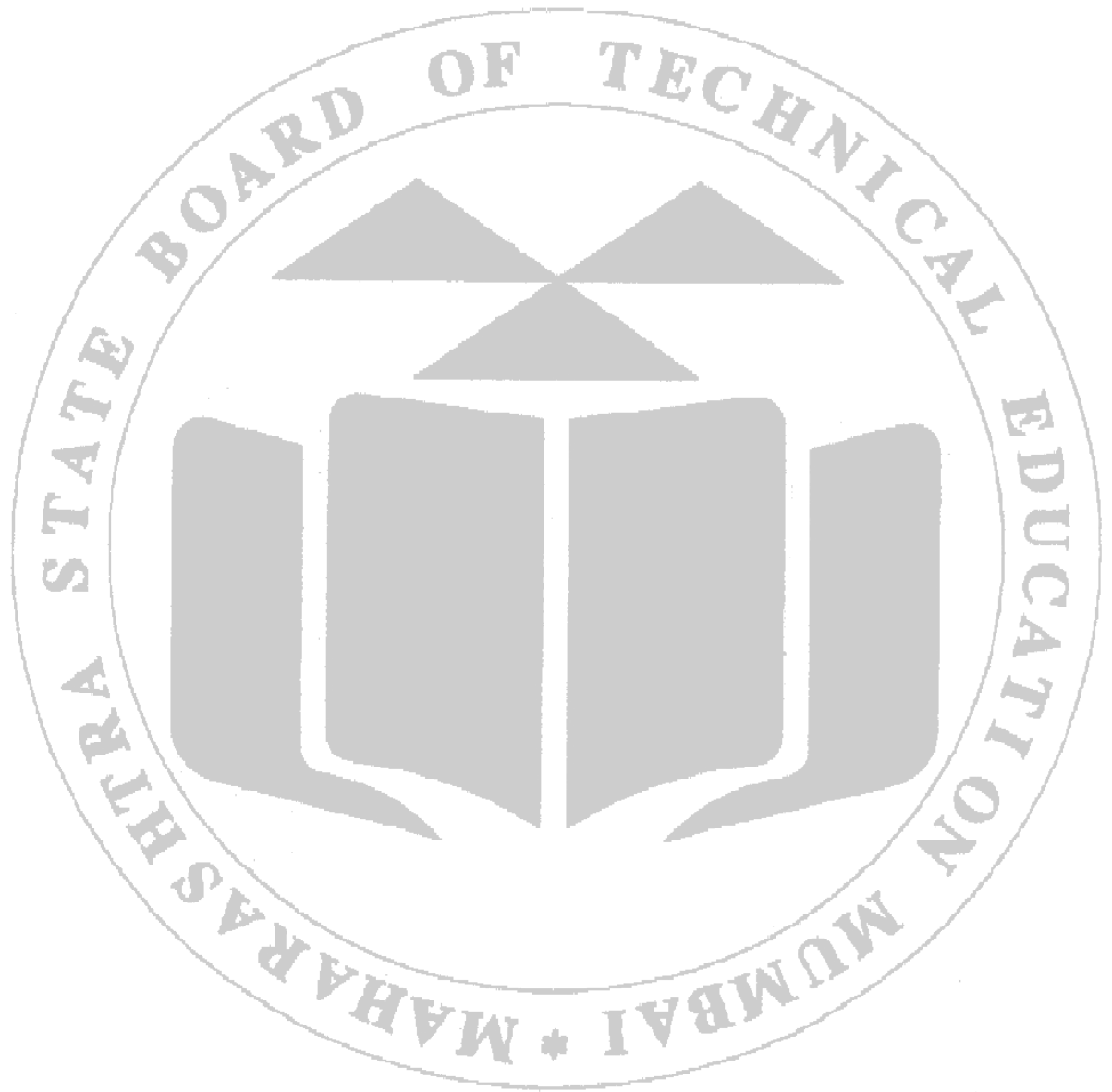

## Preface

The primary focus of any engineering laboratory/ field work in the technical education system is to develop the much-needed industry relevant competencies and skills. With this in view, MSBTE embarked on this innovative 'K' Scheme curricula for engineering diploma programs with National Education Policy 2020 (NEP2020) and outcome-based education as the focus and accordingly, relatively large amount of time is allotted for the practical work. This displays the great importance of laboratory work making each teacher; instructor and student to realize that every minute of the laboratory time need to be effectively utilized to develop these outcomes, rather than doing other mundane activities. Therefore, for the successful implementation of this outcome-based curriculum, every practical has been designed to serve as a '*vehicle*' to develop this industry identified competency in every student. The practical skills are difficult to develop through 'chalk and duster' activity in the classroom situation. Accordingly, the 'K' scheme laboratory manual development team designed the practical to *focus* on the *outcomes*, rather than the traditional age-old practice of conducting practical to 'verify the theory' (which may become a byproduct along the way).

This laboratory manual is designed to help all stakeholders, especially the students, teachers and instructors to develop in the student the pre-determined outcomes. It is expected from each student that at least a day in advance, they have to thoroughly read through the concerned practical procedure that they will do the next day and understand the minimum theoretical background associated with the practical. Every practical in this manual begins by identifying the competency, industry relevant skills, course outcomes and practical outcomes which serve as a key focal point for doing the practical. The students will then become aware about the skills they will achieve through procedure shown there and necessary precautions to be taken, which will help them to apply in solving real-world problems in their professional life.

This manual also provides guidelines to teachers and instructors to effectively facilitate student-centered lab activities through each practical exercise by arranging and managing necessary resources in order that the students follow the procedures and precautions systematically ensuring the achievement of outcomes in the students.

Knowledge of various mechanisms and machines is a pre-requisite for enabling a mechanical engineer to work in an industry. This course provides the knowledge of kinematics and dynamics of different machine elements and popular mechanisms such as four link mechanisms, cam-follower, belt-pulley, chain sprocket, gears, flywheel, brake and clutch to enable a diploma holder to carry out maintenance of these and it also serves as a prerequisite for course 'Elements of Machine Design' to be studied in later semester.

The Practical manual development team wishes to thank MSBTE who took initiative in the development of curriculum and implementation and also acknowledge the contribution of individual course experts who have been involved in laboratory manual as well as curriculum development (K scheme) directly or indirectly.

Although all care has been taken to check for mistakes in this laboratory manual, yet it is impossible to claim perfection especially as this is the first edition. Any such errors and suggestions for improvement can be brought to our notice and are highly welcome.

**Lab Manual Development Team**

## Programme Outcomes (POs) to be achieved through Practical of this Course

Following POs are expected to be achieved through the practicals of the (Theory of machines) course.

- PO1. Basic and Discipline specific knowledge:** Apply knowledge of basic mathematics, science and engineering fundamentals and engineering specialization to solve the mechanical engineering problems.
- PO 2. Problem analysis:** Identify and analyse well-defined mechanical engineering problems using codified standard methods.
- PO 3. Design/ development of solutions:** Design solutions for well-defined technical problems and assist with the design of systems components or processes to meet specified needs in mechanical engineering.
- PO 4. Engineering Tools, Experimentation and Testing:** Apply modern mechanical engineering tools and appropriate technique to conduct standard tests and measurements.
- PO 5. Engineering practices for society, sustainability and environment:** Apply appropriate technology in context of society, sustainability, environment and ethical practices.
- PO 6. Project Management:** Use engineering management principles individually, as a team member or a leader to manage projects and effectively communicate about well-defined engineering activities in diverse and multidisciplinary fields.
- PO 7. Life-long learning:** Ability to analyze individual needs and engage in updating in the context of technological changes in mechanical engineering.

### List of Industry Relevant Skills-

The following industry relevant skills or the competency are expected to be developed in students by undertaking the practical's of this laboratory manual.

- a. Identify various sensors and transducers in given system.
- b. Select suitable sensor for given mechatronics system.
- c. Select suitable actuator for given mechatronics system.
- d. Prepare a program for PLC to run required output.
- e. Selection of microcontroller for specific application.

**Practical- Course Outcome matrix****Course Outcomes (COs)**

- CO1. Identify basic elements of mechatronics system such as sensors, actuators, controllers etc.
- CO2. Use sensors for different mechatronics systems.
- CO3. Use actuators for different mechatronics systems.
- CO4. Develop PLC program for various mechatronics systems.
- CO5. Use microcontroller for different mechatronics systems.

| Sr. No. | Laboratory Practical Titles  | CO 1. | CO 2. | CO 3. | CO 4. | CO 5. |
|---------|--|-------|-------|-------|-------|-------|
| 1       | Identification of Sensors, actuators available in the laboratory                               | √     | -     | -     | -     | -     |
| 2       | Identification of PLC and microcontroller available in the laboratory                          | √     | -     | -     | -     | -     |
| 3       | Development of Ladder diagram and program PLC for simple application using sensor and actuator | √     | √     | √     | √     | -     |
| 4       | Verification of Logic gate functions for the given Ladder diagram by using PLC                 | -     | -     | -     | √     | -     |
| 5       | Development of Ladder diagram and program PLC for two-way switch logic for staircase lighting  | √     | √     | √     | -     | -     |
| 6       | Development of Ladder diagram and program PLC for Timers and Counters                          | -     | -     | -     | √     | -     |
| 7       | Development of Ladder diagram and program PLC for water level control                          | √     | √     | √     | √     | -     |
| 8       | Development of Ladder diagram and program PLC for pedestrian light (green/red) toggle control  | √     | √     | √     | √     | -     |
| 9       | Development of Ladder diagram and program PLC for on/off temperature control                   | √     | √     | √     | √     | -     |
| 10      | Development of Ladder diagram and program PLC for lift/ elevator control                       | √     | √     | √     | √     | -     |
| 11      | Development of Ladder diagram and program PLC for single acting/double acting pneumatic system | √     | √     | √     | √     | -     |
| 12      | Development of Ladder diagram and program PLC for single acting/double acting hydraulic system | √     | √     | √     | √     | -     |
| 13      | Development of Ladder diagram and program PLC for door open and close application              | √     | √     | √     | √     | -     |
| 14      | Development of Ladder diagram and program PLC for material rejection system                    | √     | √     | √     | √     | -     |
| 15      | Development of 8051 microcontroller program for stepper motor control                          | √     | √     | -     | -     | √     |
| 16      | Development of 8051 microcontroller program for relay interfacing                              | √     | √     | -     | -     | √     |

### Guidelines to Teachers

1. **Teacher need to ensure that a dated log book** for the whole semester, apart from the laboratory manual is maintained by every student which s/he has to **submit for assessment to the teacher** in the next practical session.
2. There will be two sheets of blank pages after every practical for the student to report other matters (if any), which is not mentioned in the printed practical.
3. For difficult practical if required, teacher could provide the demonstration of the practical emphasizing of the skills which the student should achieve.
4. Teachers should give opportunity to students for hands-on after the demonstration.
5. Assess the skill achievement of the students and COs of each unit.
6. One or two questions ought to be added in each practical for different batches. For this teacher can maintain various practical related question banks for each course.
7. If some repetitive information like data sheet, use of software tools etc. has to be provided for effective attainment of practical outcomes, they can be incorporated in Appendix.
8. For effective implementation and attainment of practical outcomes, teacher ought to ensure that in the beginning itself of each practical, students must read through the complete write-up of that practical sheet.
9. During practical, ensure that each student gets chance and takes active part in taking observations/readings and performing practical.
10. Teacher ought to assess the performance of students continuously according to the MSBTE guidelines

### Instructions for Students

1. For incidental writing on the day of each practical session every student should maintain a **dated log book** for the whole semester, apart from this laboratory manual which s/he has to **submit for assessment to the teacher** in the next practical session.
2. For effective implementation and attainment of practical outcomes, in the beginning itself of each practical, students need to read through the complete write-up including the practical related questions and assessment scheme of that practical sheet.
3. Student ought to refer the data books, IS codes, Safety norms, Technical Manuals, etc.
4. Student should not hesitate to ask any difficulties they face during the conduct of practical.

**Content Page****List of Practical and Progressive Assessment Sheet**

| Sr. No | Laboratory Practical Titles   | Page No. | Date of performance | Date of submission | FA PR marks (25) | Dated sign. of teacher | Remarks (if any) |
|--------|---|----------|---------------------|--------------------|------------------|------------------------|------------------|
| 1      | *Identification of Sensors, actuators available in the laboratory                               | 1        |                     |                    |                  |                        |                  |
| 2      | *Identification of PLC and microcontroller available in the laboratory                          | 08       |                     |                    |                  |                        |                  |
| 3      | *Development of Ladder diagram and program PLC for simple application using sensor and actuator | 15       |                     |                    |                  |                        |                  |
| 4      | *Verification of Logic gate functions for the given Ladder diagram by using PLC                 | 22       |                     |                    |                  |                        |                  |
| 5      | Development of Ladder diagram and program PLC for two-way switch logic for staircase lighting   | 31       |                     |                    |                  |                        |                  |
| 6      | *Development of Ladder diagram and program PLC for Timers and Counters                          | 36       |                     |                    |                  |                        |                  |
| 7      | Development of Ladder diagram and program PLC for water level control                           | 43       |                     |                    |                  |                        |                  |
| 8      | Development of Ladder diagram and program PLC for pedestrian light (green/red ) toggle control  | 50       |                     |                    |                  |                        |                  |
| 9      | *Development of Ladder diagram and program PLC for on/off temperature control                   | 56       |                     |                    |                  |                        |                  |
| 10     | Development of Ladder diagram and program PLC for lift/ elevator control                        | 63       |                     |                    |                  |                        |                  |
| 11     | Development of Ladder diagram and program PLC for single acting/double acting pneumatic system  | 70       |                     |                    |                  |                        |                  |
| 12     | Development of Ladder diagram and program PLC for single acting/double acting hydraulic system  | 77       |                     |                    |                  |                        |                  |
| 13     | Development of Ladder diagram and program PLC for door open and close application               | 84       |                     |                    |                  |                        |                  |
| 14     | *Development of Ladder diagram and program PLC for material rejection system                    | 90       |                     |                    |                  |                        |                  |
| 15     | Development of 8051 microcontroller program for stepper motor control                           | 98       |                     |                    |                  |                        |                  |

| Sr. No | Laboratory Practical Titles  | Page No. | Date of performance | Date of submission | FA PR marks (25) | Dated sign. of teacher | Remarks (if any) |
|--------|--|----------|---------------------|--------------------|------------------|------------------------|------------------|
| 16     | *Development of 8051 microcontroller program for relay interfacing | 105      |                     |                    |                  |                        |                  |
| Total  |  |          |                     |                    |                  |                        |                  |

*Note: To be transferred to Proforma of CIAAN-2023.*

A suggestive list of LLOs is given in the above table. More such LLOs can be added to attain the COs and competency. A judicious mix of minimum 12 or more practical need to be performed, out of which, the practical marked as “\*” are compulsory, so that the student reaches the ‘Precision Level’ of Dave’s ‘Psychomotor Domain Taxonomy’ as generally required by the industry.

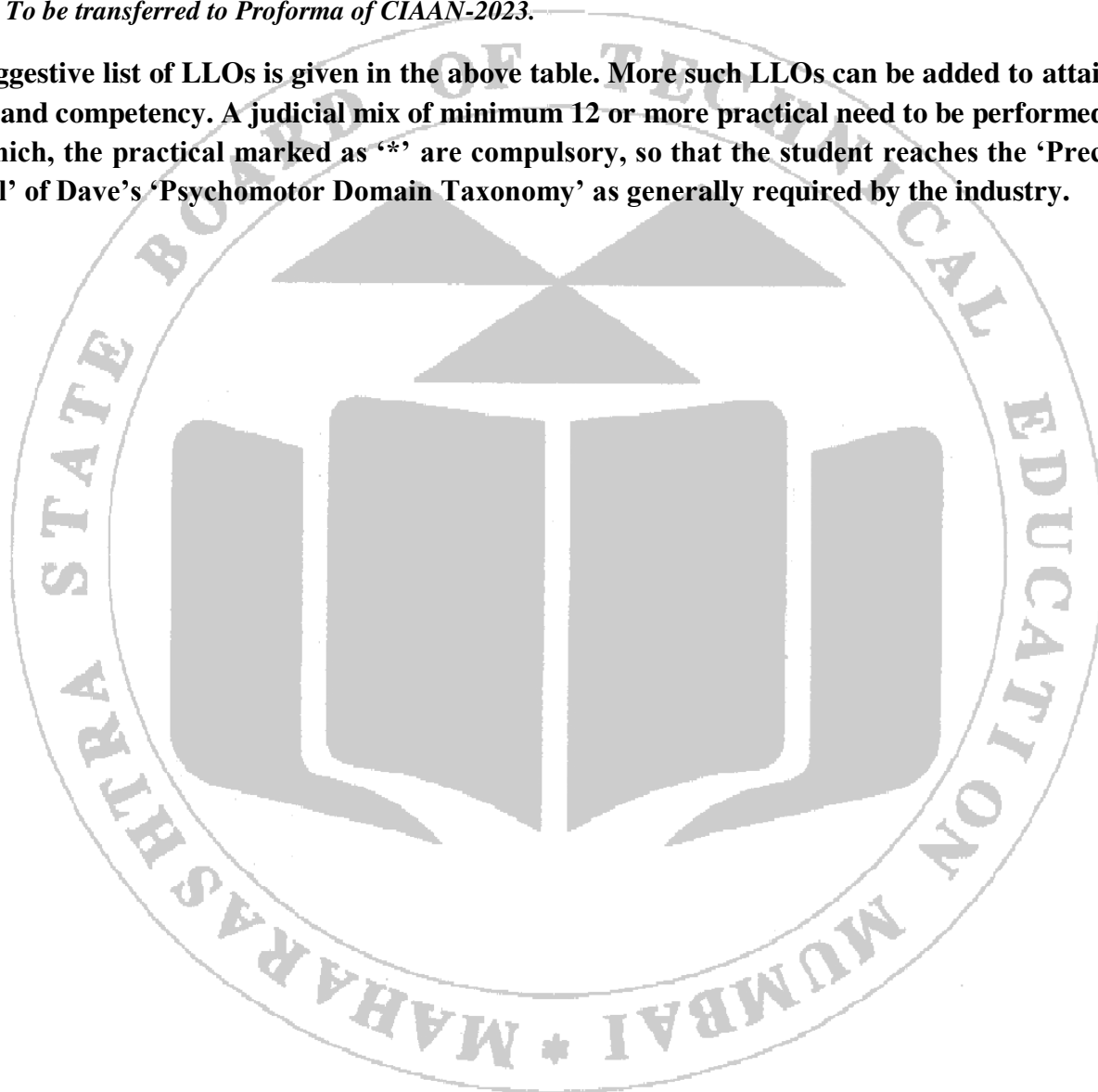

## **Practical No.1**

### **Identification of Sensors, actuators available in the laboratory**

#### **I. Practical Significance**

Sensors and actuators, are the integral parts of Mechatronic system. Proper selection and integration of them is crucial in mechatronics systems. Sensors play an important role in modern manufacturing process control. Choosing suitable devices wisely for the intended application will optimize the system to generate accurate result.

#### **II. Industry/Employer Expected Outcome (s)**

This practical is expected to develop the following skills for the industry/Employer

- Identify various sensors and transducers in given system.

#### **III. Course Level Learning Outcome (CO)**

CO1 - Identify basic elements of mechatronics system such as sensors, actuators .

#### **IV. Laboratory Learning Outcome(s)**

LLO 1.1 Identify sensor, transducer and

#### **V. Relative Affective Domain Related Outcome(s)-**

- Follow safety practices.
- Demonstrate working as a leader/a team member.
- Maintain sensors and equipment.
- Follow ethical Practices.





#### **VI. Minimum Theoretical Background with diagram (if required)**

Before performing this practical student must have knowledge of various sensors and their functions. Sensor is an element which produces a signal relating to the quantity being measured. They convert mechanical, magnetic, thermal, optical, and chemical variations into electric voltages and currents. Depending on what they measure, sensors are usually categorized.



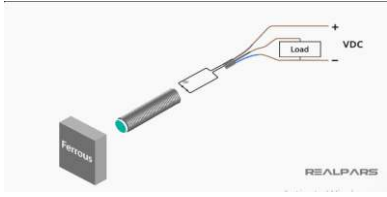

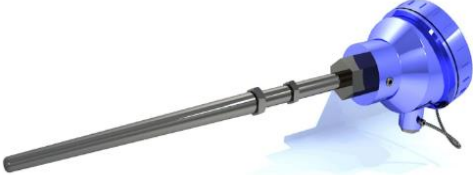
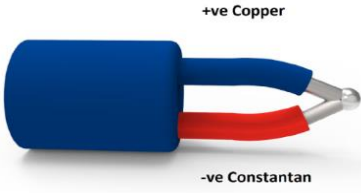
#### **VII. Experimental setup**

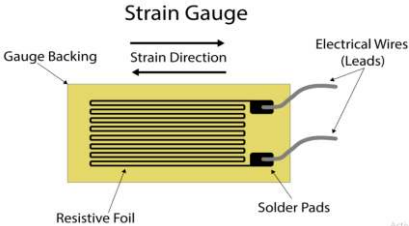
Students are suggested to visit Basics of Mechatronics lab and to identify various sensors.

**Table 1.1: Different sensors for reference**

| TYPE OF SENSOR                | PHOTO FOR REFERENCE   |
|-------------------------------|---|
| Inductive proximity sensor    |  <p>A photograph of an inductive proximity sensor. It is a cylindrical metal component with a blue tip. A wire is connected to the side, leading to a circuit diagram showing a DC voltage source (VDC) connected to a load. A small black rectangular object labeled 'FERROUS' is positioned near the sensor tip. The brand name 'REALPARS' is visible at the bottom right of the image.</p>                   |
| Capacitive Proximity sensor   |  <p>Two capacitive proximity sensors are shown. One is a blue cylindrical sensor with a black mounting bracket. The other is a similar sensor with a different mounting bracket.</p>  |
| Resistance Temperature sensor |  <p>A Resistance Temperature sensor (RTD) is shown. It consists of a long, thin metal probe with a blue plastic housing at the end. The probe is shown with a blue glow at its tip, indicating it is in use.</p>  |
| Thermocouple                  |  <p>A thermocouple is shown. It has a blue plastic housing and two wires extending from the end. The wires are labeled '+ve Copper' and '-ve Constantan'.</p>   |
| Photo diode                   |  <p>Two photo diodes are shown. One is a small, rectangular component with two leads. The other is a similar component with a different lead configuration.</p>   |
| Strain Gauge                  |  <p>A diagram of a strain gauge. It shows a rectangular component with a yellow 'Gauge Backing' and a 'Resistive Foil' pattern. The foil consists of several parallel lines. 'Electrical Wires (Leads)' are connected to the foil, and 'Solder Pads' are shown at the bottom. A 'Strain Direction' arrow points to the right. The brand name 'Activate WI' is visible at the bottom right of the diagram.</p> |

**Table 1.2: Different Actuators for reference**

| Type of actuator                           | Photo  |
|--|--|
| <p><b>Electric Motor</b></p>               |  <p><b>AC MOTOR</b>                      <b>DC MOTOR</b></p> |
| <p><b>Stepper Motor</b></p>                |   |
| <p><b>Solenoid</b></p>                     |   |
| <p><b>Hydraulic/pneumatic Actuator</b></p> |    |

**VIII. Required Resources /Apparatus/Equipment with specification**

| Sr. No. | Name of Resource              | Suggested Broad Specification  | Quantity |
|---------|-------------------------------|--|----------|
| 1       | Inductive proximity sensor    | Sensing distance: 2 mm $\pm$ 10%, 4 mm $\pm$ 10%, 5 mm $\pm$ 10%, 8 mm $\pm$ 10%, 12 mm $\pm$ 10%<br>Differential Travel: max. 10% of sensing distance<br>Detectable Object: Ferrous metal<br>Power Supply Voltage (Operating Voltage Range): 12 to 24 VDC, ripple (p-p): max. 10%<br>Current Consumption: 15 mA max | 1        |
| 2       | Capacitive Proximity sensor   | Diameter : 18 mm<br>Sensing range : 10 mm ( adjustable )<br>Operating Voltage : 10-35 VDC<br>Max Load Current : 300mA  | 1        |
| 3       | Resistance Temperature sensor | Accuracy : $\pm$ 0.01 $\Omega$ at 0 $^{\circ}$ C<br>Stability* : -130 to 93 $^{\circ}$ C $\pm$ 0.05%<br>Temp Range : 250 to 1000 $^{\circ}$ C, -200 to 600 $^{\circ}$ C<br>Measuring Current : 10 milliamps DC max   | 1        |
| 4       | Thermocouple                  | Type: R or S temp. range: 0 to 1,480 32 to 2,700   | 1        |
| 5       | Photo diode                   | Rise time < 15 ps, bandwidth > 25 GHz, spectral range 800 - 1700 nm,   | 1        |
| 6       | Strain Gauge                  | Service temperature: -75 to 200 <sup>0</sup> C<br>Maximum strain: 1.5 %  | 1        |

**IX. Precautions to be Followed**

- Avoid improper handling of equipment.
- Follow safety practices about maintaining tools and equipment.

**X. Procedure**

1. Identify the type of application intended.
2. Explore the available sensors/actuators/PLCs/Microcontroller in laboratory needed for identified application.
3. Shortlist the components from the available resources.
4. Apply the standard selection criteria for each of the component shortlisted.
5. Select the most suitable component for the given application
6. Repeat above steps for different types of sensors/actuators.

**XI. Observations and calculations**

**Table 1.1: Selection criteria for sensors**

| Sr. No. | Name of the sensor | Selection Criterion used | Remarks if any |
|---------|--------------------|--------------------------|----------------|
|         |                    |                          |                |
|         |                    |                          |                |
|         |                    |                          |                |
|         |                    |                          |                |
|         |                    |                          |                |

**Table 1.2 : Selection criteria for Actuators**

| Sr. No. | Name of the actuator | Selection Criterion used | Remarks if any |
|---------|----------------------|--------------------------|----------------|
| 1       |                      |                          |                |
| 2       |                      |                          |                |
| 3       |                      |                          |                |
| 4       |                      |                          |                |
| 5       |                      |                          |                |

**XII. Results**

.....

.....

.....

.....

**XIII. Interpretation of Results**

.....

.....



-----

-----

-----

-----

-----

-----

-----

-----

-----

**XVI. References / Suggestions for Further Reading**

You tube video: [https://youtu.be/qiHS1\\_Vr7SI?si=Bj2dbPQMAO7v0T4F](https://youtu.be/qiHS1_Vr7SI?si=Bj2dbPQMAO7v0T4F)

**XVII Rubrics for Assessment Scheme**

| Performance Indicators            |                                       | Weightage    |
|-----------------------------------|---------------------------------------|--------------|
| <b>Process Related (15 Marks)</b> |                                       | <b>(20%)</b> |
| 1                                 | Handling of the measuring Instruments | 20%          |
| 2                                 | Calculation of final readings         | 00%          |
| <b>Product Related (10 Marks)</b> |                                       | <b>(80%)</b> |
| 3                                 | Interpretation of result              | 40%          |
| 4                                 | Conclusions                           | 20%          |
| 5                                 | Practical related questions           | 20%          |
| <b>Total</b>                      |                                       | <b>100 %</b> |

| Marks Obtained      |                      |            | Dated signature of Teacher |
|---------------------|----------------------|------------|----------------------------|
| Process Related (5) | Product Related (20) | Total (25) |                            |
|                     |                      |            |                            |

## Practical No. 02

### Identification of PLC and microcontroller available in the laboratory

#### I. Practical Significance

PLCs and microcontrollers are the integral parts of Mechatronics systems. Proper selection and integration of them is crucial in mechatronics systems. Choosing suitable devices wisely for the intended application will optimize the system to generate accurate result.

#### II. Industry/Employer Expected Outcome (s)

This practical is expected to develop the following skills for the industry/Employer  
- Identify various sensors and transducers in given system.

#### III. Course Level Learning Outcome (CO)

CO1 - Identify basic elements of mechatronics system such as sensors, actuators, controllers etc.

#### IV. Laboratory Learning Outcome(s)

LLO 2.1 Identify PLC and microcontroller

#### V. Relative Affective Domain Related Outcome(s)-

- Follow safety practices.
- Practice good housekeeping.
- Demonstrate working as a leader/a team member.
- Maintain tools and equipment.
- Follow ethical Practices Follow ethical Practices.

#### VI. Minimum Theoretical Background with diagram

Before performing this practical student must have knowledge of PLC, Microcontroller and their functions. A programmable logic controller is a type of tiny computer that can receive data through its inputs and send operating instructions through its outputs. Fundamentally, a PLC's job is to control a system's functions using the internal logic programmed into it. A microcontroller is a compact integrated circuit designed to govern a specific operation in an embedded system. A typical microcontroller includes a processor, memory and input/output (I/O) peripherals on a single chip.

**Experimental setup (Model)-**



**Fig. 2.1: A photograph of PLC trainer kit**

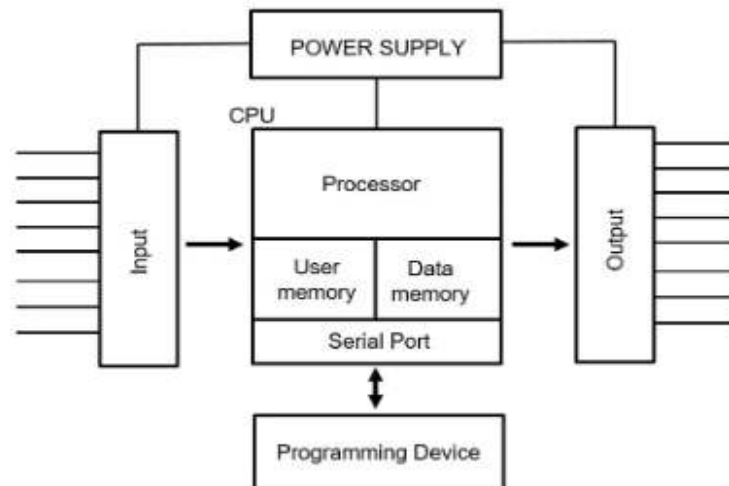

**Fig. 2.2: Block diagram of a PLC**

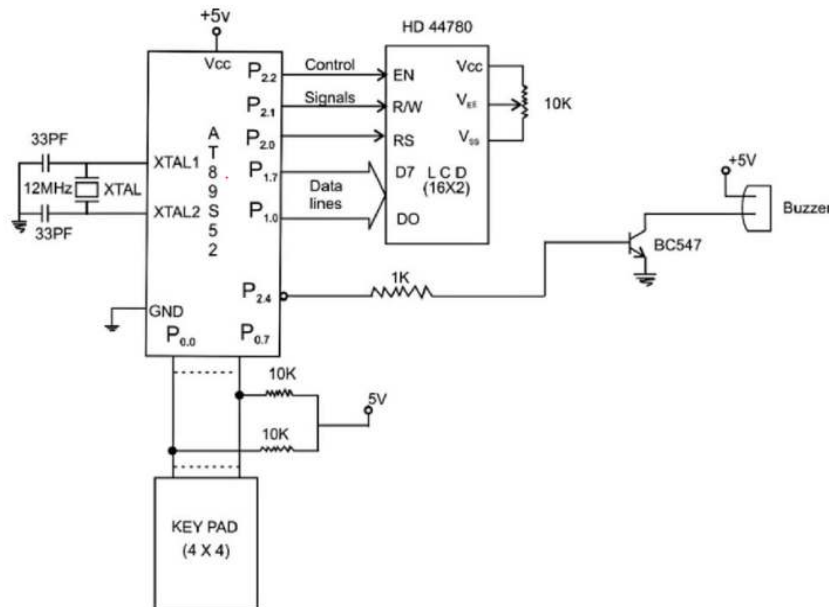

**Fig. 2.3: Block diagram of Microcontroller**

**VII. Required Resources /Apparatus/Equipment with specification**

| Sr. No. | Name of Resource              | Suggested Broad Specification  | Quantity |
|---------|-------------------------------|--|----------|
| 1       | Programmable logic controller | Digital input: 12 nos. with toggle switches for applying 24V dc inputs.<br>Digital Outputs:-12 Nos with 24V operated Lamp.<br>Analog Inputs: - 02<br>Analog Outputs: - 02<br>External Power Supply: 24 V DC.<br>Memory:-16 K data memory +351K Code Memory +96K upload Memory. | 01       |
| 2       | Computer/Laptop               | PC preloaded with required PLC software and I/O communication facility.  | 01       |
| 3       | Microcontroller               | AT89S51 40 pin DIP package,+5VDC operating voltage, 4K EEPROM/Flash Memory, 128 Bytes of SRAM, Four 8-bit IO Ports, Two 16-bit timer/counter, 6 interrupts   | 01       |

**VIII. Precautions to be Followed**

- Avoid improper handling of instrument.
- Follow safety practices about maintaining tools and equipment.

**IX. Procedure**

1. Identify the type of application intended.
2. Explore the available PLCs/Microcontroller in laboratory needed for identified application.
3. Shortlist the components from the available.
4. Apply the standard selection criteria for each of the component shortlisted.
5. Select the most suitable component for the given application

Repeat above steps for different types of sensors/actuators PLCs/Microcontroller Observations and calculations.

**X. Resources used:**

| Sr. No. | Name of Recourse | Broad Specifications |         | Quantity | Remarks (if any) |
|---------|------------------|----------------------|---------|----------|------------------|
|         |                  | Make                 | Details |          |                  |
| 1       |                  |                      |         |          |                  |
| 2       |                  |                      |         |          |                  |

| Sr. No. | Name of Recourse | Broad Specifications |         | Quantity | Remarks (if any) |
|---------|------------------|----------------------|---------|----------|------------------|
|         |                  | Make                 | Details |          |                  |
| 1       |                  |                      |         |          |                  |
| 3       |                  |                      |         |          |                  |
| 4       |                  |                      |         |          |                  |

**XI. Actual Procedure Followed:**

-----

-----

-----

-----

**XII. Precautions Followed:**

-----

-----

-----

**XIII. Observations and Calculations:**

**Table 2.1: Selection criteria for PLC**

| Sr. No. | Name of the PLC | Selection Criterion Used | Comments |
|---------|-----------------|--------------------------|----------|
| 1       |                 |                          |          |
| 2       |                 |                          |          |
| 3       |                 |                          |          |

**Table 2.2: Selection criteria for Microcontroller**

| Sr. No. | Name of the Microcontroller | Selection Criterion Used | Comments |
|---------|-----------------------------|--------------------------|----------|
| 1       |                             |                          |          |
| 2       |                             |                          |          |

**XII. Results**

-----

-----

-----

-----

-----

-----

-----

-----

-----

-----

-----

**XIII. Interpretation of Results**

-----

-----

-----

-----

-----

-----

-----

**XIV. Conclusions and Recommendation**

-----

-----

-----

-----

-----

-----

-----

**XV Practical Related Questions**

*Note: Below given are few sample questions for reference. Teachers must design more such questions so as to ensure the achievement of identified CO.*

1. List the various manufacturers of PLCs and compare their features.
2. List the various manufacturers of microcontroller.
3. State different applications of PLCs.

**[Space for Answer]**

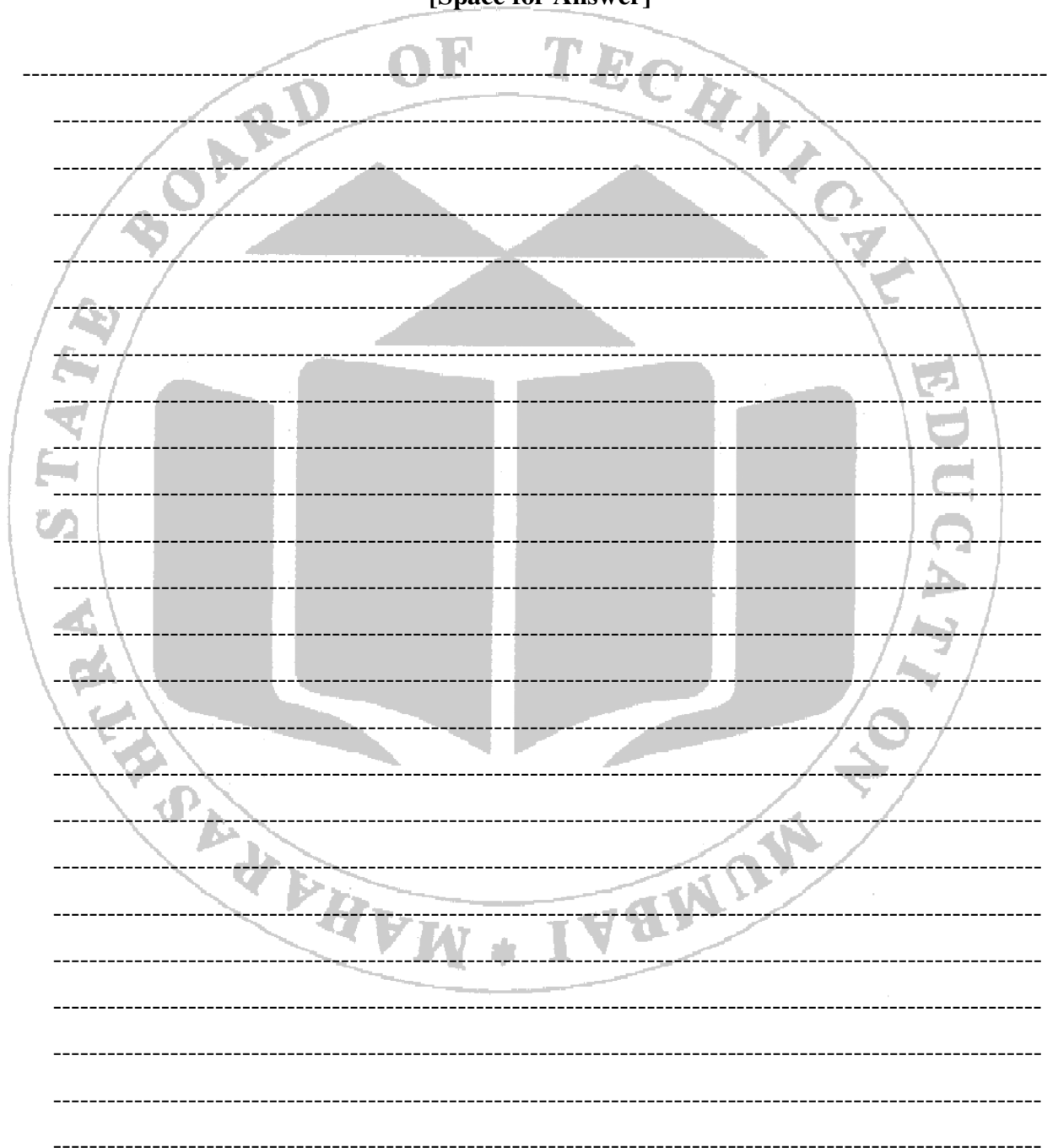

**XVI. References / Suggestions for Further Reading**

<https://www.youtube.com/watch?v=EeRXSKfaYjA>

<https://youtu.be/OHGzvnMFH0k?si=NinaqL76gaZqxy0K>

**XVII Rubrics for Assessment Scheme**

| <b>Performance Indicators</b>     |                                   | <b>Weightage</b> |
|-----------------------------------|-----------------------------------|------------------|
| <b>Process Related (15 Marks)</b> |                                   | <b>(20%)</b>     |
| 1                                 | Handling of the models/set up     | 20%              |
| 2                                 | Observations of the models/set up | 00%              |
| <b>Product Related (10 Marks)</b> |                                   | <b>(80%)</b>     |
| 3                                 | Interpretation of result          | 40%              |
| 4                                 | Conclusions                       | 20%              |
| 5                                 | Practical related questions       | 20%              |
| <b>Total</b>                      |                                   | <b>100 %</b>     |

| <b>Marks Obtained</b>       |                             |                   | <b>Dated signature of Teacher</b> |
|-----------------------------|-----------------------------|-------------------|-----------------------------------|
| <b>Process Related (15)</b> | <b>Product Related (10)</b> | <b>Total (25)</b> |                                   |
|                             |                             |                   |                                   |

## **Practical No. 03**

### **Development of Ladder diagram and program PLC for simple application using sensors and actuators.**

#### **I. Practical Significance**

Idea creation and its implementation lead to building the small to medium and medium to large scale applications. Preparing small circuits using sensors and actuators is the initial step towards building application oriented competencies that will make the students to understand the basics of ladder diagram.

This will make the students to understand how ladder diagram is build and executed at basic level.

#### **II. Industry/Employer Expected Outcome (s)**

This practical is expected to develop the following skills for the industry/Employer.

1. To develop a simple circuit.
2. Prepare a ladder diagram and execute the program.

#### **III. Course Level Learning Outcome (CO)**

CO1- Identify basic elements of mechatronics system such as sensors, actuators, controllers,etc.

CO2. Use sensors for different mechatronics systems.

CO3. Use actuators for different mechatronics systems.

CO4. Develop PLC program for various mechatronics systems.

#### **IV. Laboratory Learning Outcome(s)**

LLO3.1. Develop ladder diagram for simple application using sensor and actuator.

LLO3.2. Execute PLC program for simple application.

#### **V. Relative Affective Domain Related Outcome(s)-**

- Maintain tools and equipment.
- Follow safety practices

#### **VI. Minimum Theoretical Background**

Sensor can sense the desired quantity and give output in the form for variable electrical signal. It is required to process this signal and get the output in required form. First step to run a circuit by using PLC is to make a program for desired output, feed this to PLC make the connections and get the output.

## VII. Experimental setup (Model)-

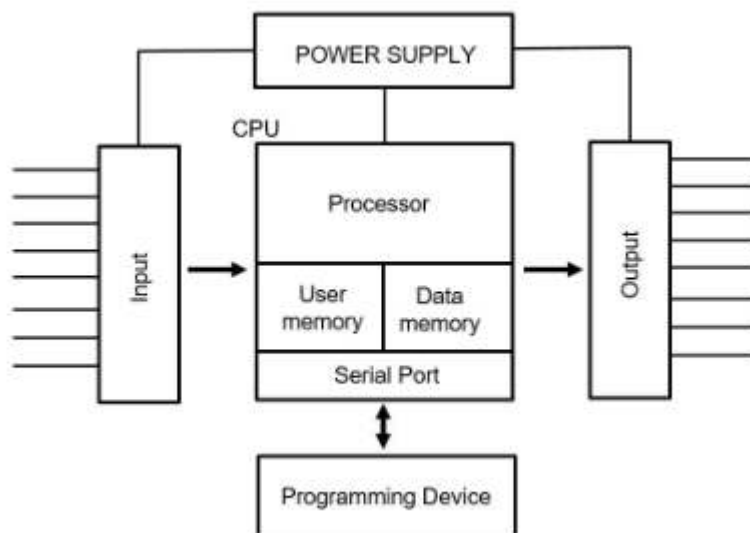

**Fig. 3.1: Block Diagram of PLC**

## VIII. Required Resources /Apparatus/Equipment with specification

| Sr. No. | Name of Resource              | Suggested Broad Specification  | Quantity |
|---------|-------------------------------|--|----------|
| 1       | Programmable logic controller | Digital input: 12 nos. with toggle switches for applying 24V dc inputs.<br>Digital Outputs:-12 Nos with 24V operated Lamp.<br>Analog Inputs: - 02<br>Analog Outputs: - 02<br>External Power Supply: 24 V DC.<br>Memory:-16 K data memory +351K Code Memory +96K upload Memory. | 01       |
| 2       | Computer/Laptop               | PC preloaded with required PLC software and I/O communication facility.  | 01       |
| 3       | Proximity Sensor              | Operating Input Voltage: 12V DC<br>Proximity Sensor<br>Sensor Type: PNP<br>Sensing Range: 0-10mm<br>Output Voltage: 12V DC   | 01       |
| 4       | Limit Switch                  | Current Rating: 5A<br>Voltage Rating: 125-250 V AC<br>Limit Switch<br>Contact Resistance: 30m2 Max   | 01       |

| Sr. No. | Name of Resource | Suggested Broad Specification  | Quantity |
|---------|------------------|--|----------|
|         |                  | Insulation Resistance: 100M $\Omega$<br>Min<br>Dielectric Strength: 1500VAC for<br>1 Minute                        |          |
| 5       | Optical Sensor   | Transmitter: IR LED<br>Optical Sensor<br>Operating Input Voltage-5V DC<br>Sensing Range-0-10mm<br>Wavelength-940nm | 01       |

**\*Student can select any available sensor in Lab**

### IX. Precautions to be Followed

- Maintain tools and equipment.
- Follow safety practices.

### X. Procedure

1. Open the PLC Software.
2. Create new project.
3. Develop ladder diagram for object detector controller.
4. Test and correct the errors (if any).
5. Download the program on PLC.
6. Connect DI0, DI1, DI2 and DI3 of Sensor Module to respective inputs of PLC.
7. Connect DO0, DO1, DO2 and DO3 of Sensor Module to respective outputs of PLC.
8. Bring a metal object near the first sensor i.e. inductive proximity sensor and observe the output of DIO and DO0.
9. Bring any object near the second sensor i.e. Capacitive proximity sensor and observe the output of DI1 and DO1.
10. Bring any object near the third sensor i.e. inductive proximity sensor and observe the output of DI2 and DO2.
11. Bring any object near the fourth sensor i.e. optical proximity sensor and observe the output of DI3 and DO3.

(Note: Elaborate stepwise procedure to develop ladder logic and download it in PLCs program memory using PLC software. The procedure may vary for different PLC software.)

### XI. LADDER LOGIC –



**XIV. Precautions Followed:**

-----  
 -----  
 -----  
 -----

**XV. Observations and Calculations:**

| Sr. No. | Name of the object | Distance in mm | Sensor Output |
|---------|--------------------|----------------|---------------|
|         |                    |                |               |
|         |                    |                |               |
|         |                    |                |               |
|         |                    |                |               |

**XVI. Conclusions and Recommendation**

-----  
 -----  
 -----  
 -----

**XVII. Practical Related Questions**

*Note: Below given are few sample questions for reference. Teachers must design more such questions so as to ensure the achievement of identified CO.*

1. State any two sensor and explain its applications (min. three) in mechatronics system.
2. State command/ Notations used in ladder diagram.
3. State any two actuators and its application in mechatronics system.

**[Space for Answer]**

-----  
 -----  
 -----  
 -----  
 -----  
 -----  
 -----  
 -----  
 -----  
 -----

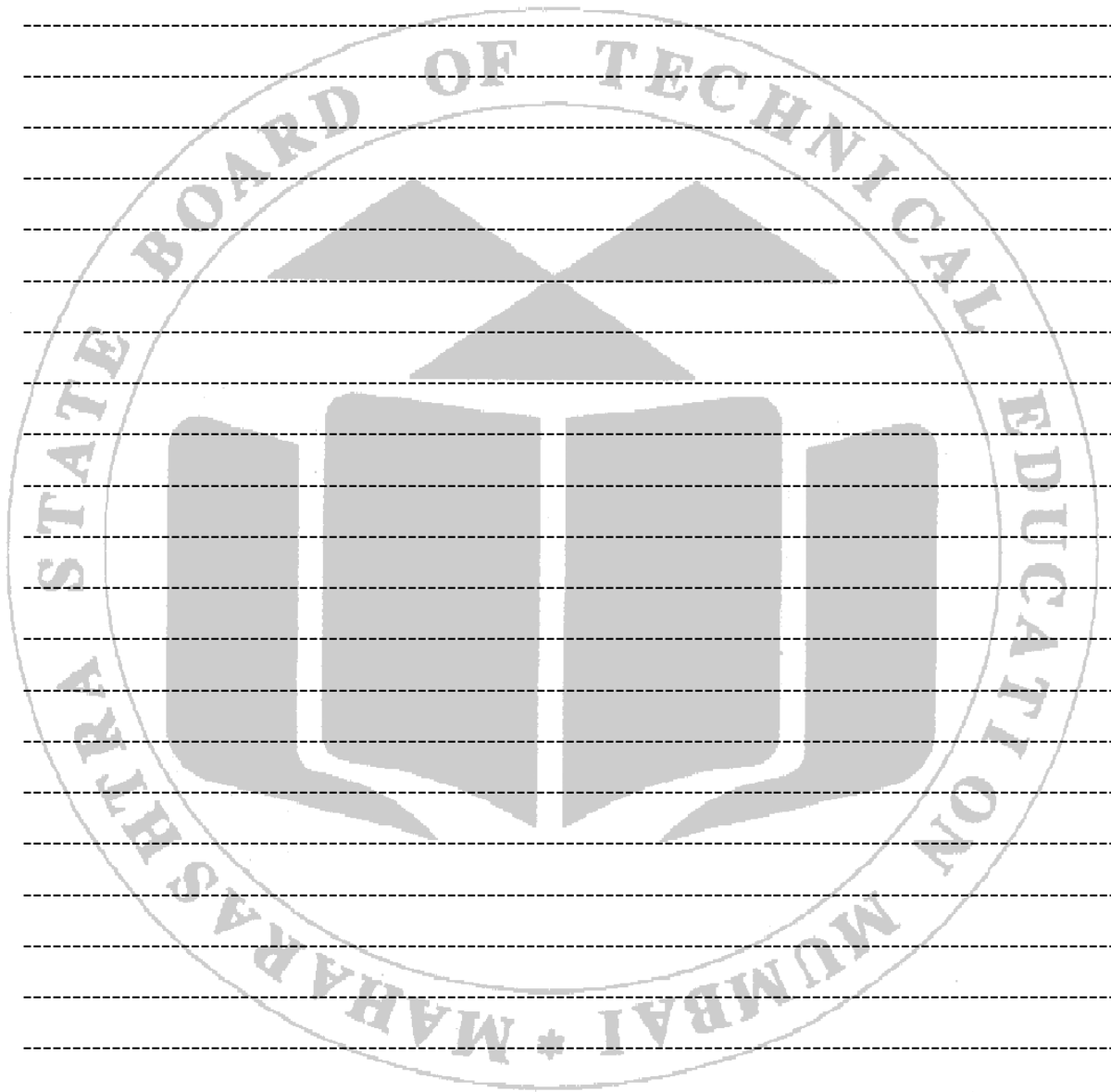

**XVIII. References / Suggestions for Further Reading**

1. <https://www.mathworks.com/help/plccoder/ladder-diagram-modelling-and-code-generation.html>
2. <https://basicplc.com/plc-programming/>

**XIX Rubrics for Assessment Scheme**

| Performance Indicators            |  | Weightage    |
|-----------------------------------|--|--------------|
| <b>Process Related (15 Marks)</b> |  | <b>(20%)</b> |
| 1                                 | Handling of the Set up/measuring Instruments | 10%          |
| 2                                 | Calculation of final readings                | 10%          |
| <b>Product Related (10 Marks)</b> |  | <b>(80%)</b> |
| 3                                 | Interpretation of result                     | 40%          |
| 4                                 | Conclusions                                  | 20%          |
| 5                                 | Practical related questions                  | 20%          |
| <b>Total</b>                      |  | <b>100 %</b> |

| Marks Obtained       |                      |            | Dated signature of Teacher |
|----------------------|----------------------|------------|----------------------------|
| Process Related (15) | Product Related (10) | Total (25) |                            |
|                      |                      |            |                            |

**Practical No. 04****Verification of Logic gate functions for the given Ladder diagram by using PLC****I. Practical Significance**

Logic gates are the basic building blocks of the digital electronic circuits. Many mechatronics systems involves digital signal which have only two possible signal levels i.e. ON and OFF. The students should be able to develop the ladder logic for the given Boolean arithmetic.

**II. Industry/Employer Expected Outcome (s)**

This practical is expected to develop the following skills for the industry/Employer

- Prepare a program for PLC to run required output

**III. Course Level Learning Outcome (CO)**

CO4. Develop PLC program for various mechatronics systems.

**IV. Laboratory Learning Outcome(s)**

LLO4.1. Develop ladder diagram for logic gates

LLO4.2. Execute PLC program for the logic gates

**V. Relative Affective Domain Related Outcome(s)-**

- Follow safety practices.
- Practice good housekeeping.
- Demonstrate working as a leader/a team member.
- Maintain tools and equipment.
- Follow ethical Practice.

**VI. Minimum Theoretical Background with diagram**

The PLC, like all digital equipment, operates on the binary principle. The binary means having only two states. These states are 1 and 0. The 1 and 0 can represent ON or OFF, open or closed, true or false, high or low, or any other two conditions. A logic gate is a circuit with several inputs but only one output that is activated by particular combinations of input conditions.

Logic Gates using switching circuits:

1. NOT Gate:

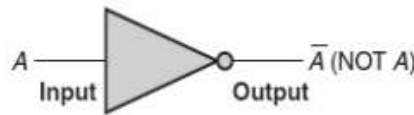

NOT truth table

| A | NOT A |
|---|-------|
| 0 | 1     |
| 1 | 0     |

Hardwired circuit

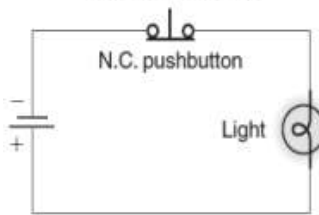

Truth table

| Pushbutton      | Light   |
|-----------------|---------|
| Not pressed (0) | On (1)  |
| Pressed (1)     | Off (0) |

Logic representation

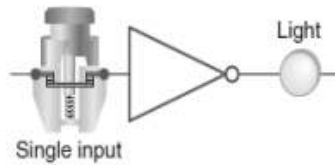

2. AND Gate:

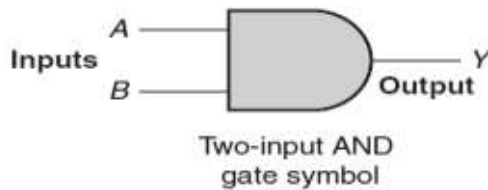

AND truth table

| Inputs |   | Output |
|--------|---|--------|
| A      | B | Y      |
| 0      | 0 | 0      |
| 0      | 1 | 0      |
| 1      | 0 | 0      |
| 1      | 1 | 1      |

Hardwired circuit

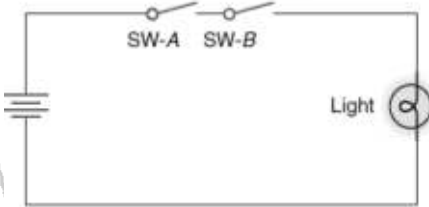

Truth table

| SW-A       | SW-B       | Light   |
|------------|------------|---------|
| Open (0)   | Open (0)   | Off (0) |
| Open (0)   | Closed (1) | Off (0) |
| Closed (1) | Open (0)   | Off (0) |
| Closed (1) | Closed (1) | On (1)  |

Logic representation

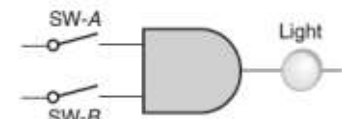

3. OR Gate:

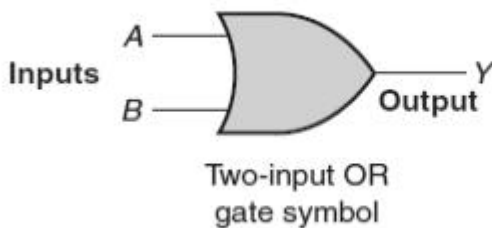

OR truth table

| Inputs |   | Output |
|--------|---|--------|
| A      | B | Y      |
| 0      | 0 | 0      |
| 0      | 1 | 1      |
| 1      | 0 | 1      |
| 1      | 1 | 1      |

Hardwired circuit

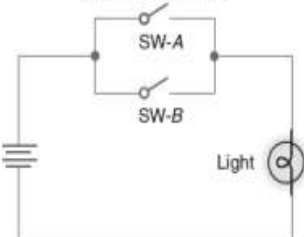

Truth table

| SW-A       | SW-B       | Light   |
|------------|------------|---------|
| Open (0)   | Open (0)   | Off (0) |
| Open (0)   | Closed (1) | On (1)  |
| Closed (1) | Open (0)   | On (1)  |
| Closed (1) | Closed (1) | On (1)  |

Logic representation

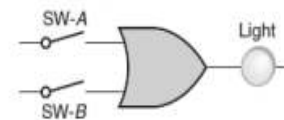

**4. X-OR Gate:**

**X-OR Gate Symbol**

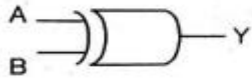

**Boolean Expression**

$$Y = A \oplus B = \bar{A}B + A\bar{B}$$

**Truth Table**

| A | B | Y |
|---|---|---|
| 0 | 0 | 0 |
| 0 | 1 | 1 |
| 1 | 0 | 1 |
| 1 | 1 | 0 |

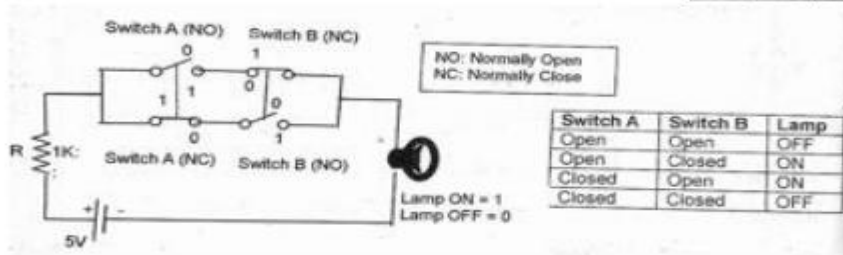

**5. X-NOR Gate:**

**X-NOR Gate Symbol**

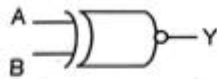

**Boolean Expression**

$$Y = \overline{A \oplus B} = \bar{A}\bar{B} + AB$$

**Truth Table**

| A | B | Y |
|---|---|---|
| 0 | 0 | 1 |
| 0 | 1 | 0 |
| 1 | 0 | 0 |
| 1 | 1 | 1 |

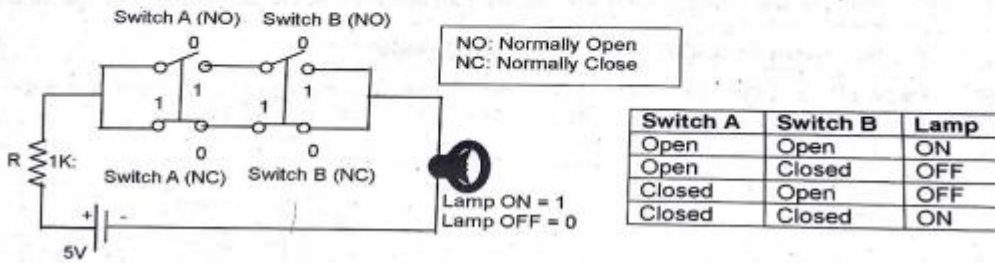

**1. NOT gate:**



**2. AND Gate:**

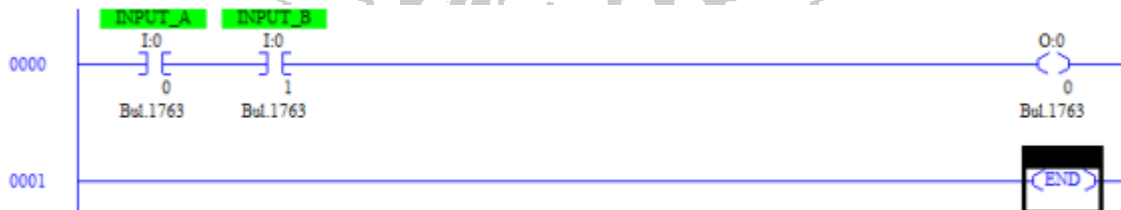

**3. OR Gate:**

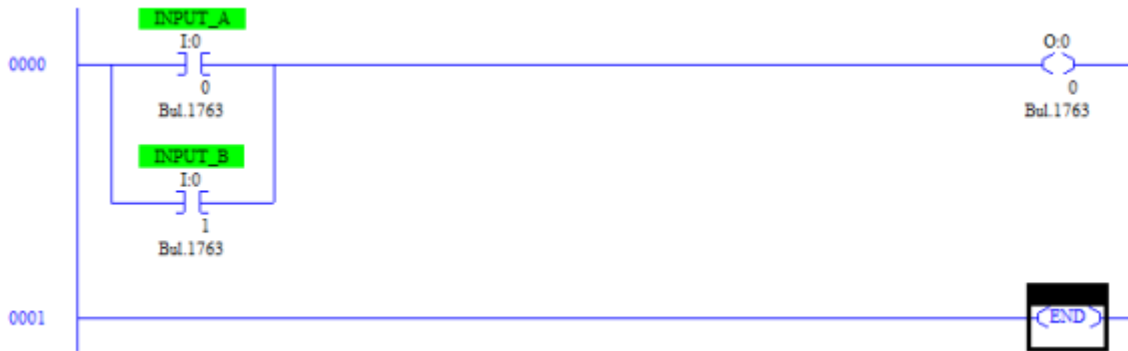

**4. X-OR Gate:**



**5. X-NOR Gate:**

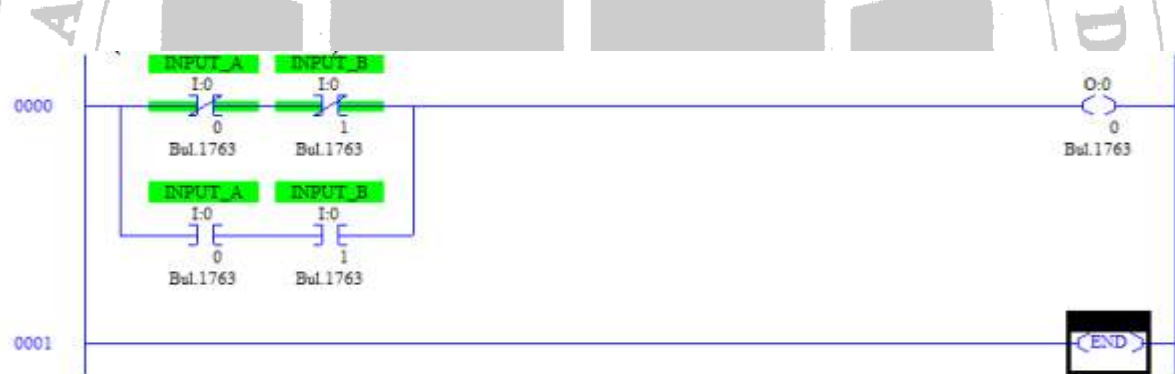

**VII. Experimental setup-**

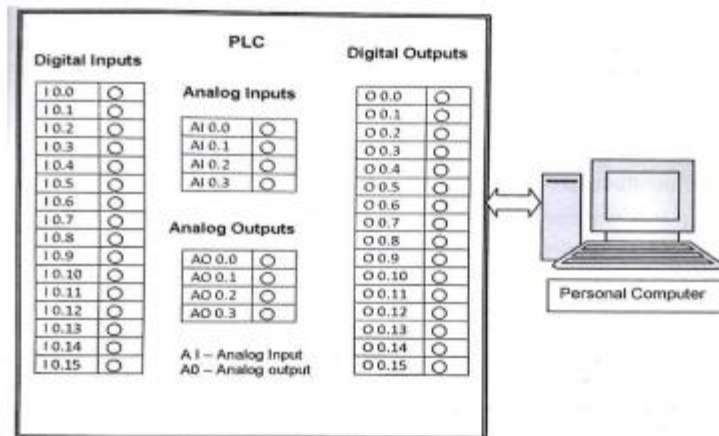

**Fig 4.1: Experimental Setup**

**VIII. Required Resources :**

| Sr. No. | Name of Resource              | Suggested Broad Specification  | Quantity |
|---------|-------------------------------|--|----------|
| 1       | Programmable logic controller | Digital input: 12 nos. with toggle switches for applying 24V dc inputs.<br>Digital Outputs:-12 Nos with 24V operated Lamp.<br>Analog Inputs: - 02<br>Analog Outputs: - 02<br>External Power Supply: 24 V DC.<br>Memory:-16 K data memory +351K Code Memory +96K upload Memory. | 01       |
| 2       | Computer/Laptop               | PC preloaded with required PLC software and I/O communication facility.  | 01       |

**IX. Precautions to be Followed**

- Maintain tools and equipment.
- Follow safety practices.

**X. Procedure**

1. Open the PLC Software.
2. Create new project.
3. Develop ladder diagram for Logic Gates.
4. Test and correct the errors (if any).
5. Download the program on PLC.
6. Make required input output connections to PLC.
7. Execute the program and observe the output on lamp by changing switch positions.
8. Repeat steps 3 to step 7 for different Logic gates.

**XI. Resource used:**

| Sr. No. | Name of Resource | Suggested Broad Specification | Quantity |
|---------|------------------|-------------------------------|----------|
|         |                  |                               |          |



**XIV. Observation and Calculations:**

**1. NOT Gate:**

| Switch | Lamp |
|--------|------|
| Open   |      |
| Closed |      |

**2. AND Gate:**

| Switch A | Switch B | Lamp |
|----------|----------|------|
| Open     | Open     |      |
| Open     | Closed   |      |
| Closed   | Open     |      |
| Closed   | Closed   |      |

**3. OR Gate:**

| Switch A | Switch B | Lamp |
|----------|----------|------|
| Open     | Open     |      |
| Open     | Closed   |      |
| Closed   | Open     |      |
| Closed   | Closed   |      |

**4. X-OR Gate**

| Switch A | Switch B | Lamp |
|----------|----------|------|
| Open     | Open     |      |
| Open     | Closed   |      |
| Closed   | Open     |      |
| Closed   | Closed   |      |

**XV. Interpretation of Results**

-----

-----

-----

-----

-----

-----

**XVI. Conclusions and Recommendation**

-----

-----

-----

-----

-----

**XVII. Practical Related Questions**

*Note: Below given are few sample questions for reference. Teachers must design more such questions so as to ensure the achievement of identified CO.*

1. Prepare a ladder logic for  $Y = (A+B)CD$ .
2. Draw the symbol and truth table for X-NOR gate.

[Space for Answer]

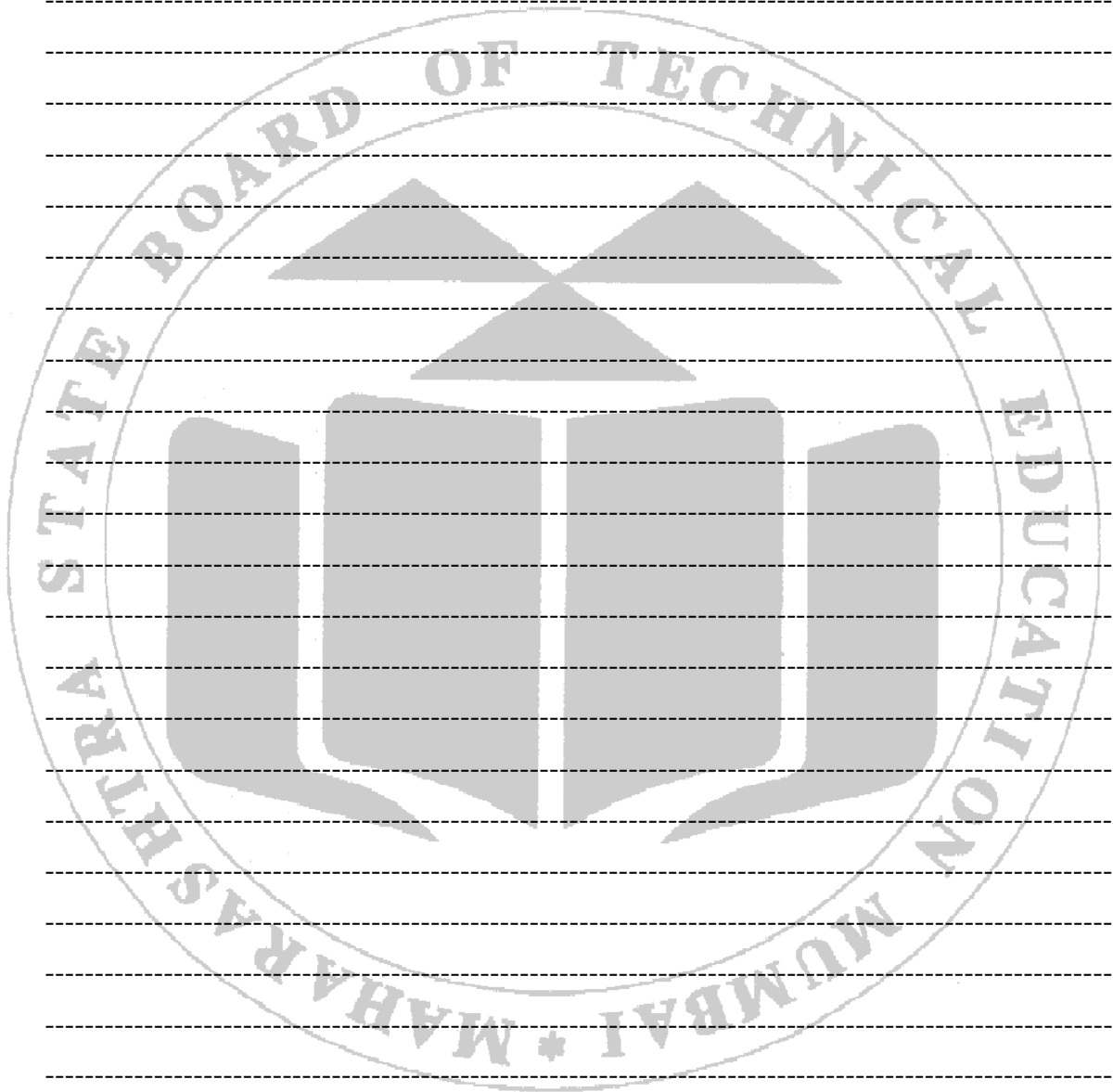

-----

-----

-----

-----

**XVIII. References / Suggestions for Further Reading**

1. <https://byjus.com/jee/basic-logic-gates/>
2. Mechatronics by W. Bolton

**XVII. Rubrics for Assessment Scheme**

| Performance Indicators            |  | Weightage    |
|-----------------------------------|--|--------------|
| <b>Process Related (15 Marks)</b> |  | <b>(20%)</b> |
| 1                                 | Handling of the measuring Instruments      | 10%          |
| 2                                 | Observations/Calculation of final readings | 10%          |
| <b>Product Related (10 Marks)</b> |  | <b>(80%)</b> |
| 3                                 | Interpretation of result                   | 40%          |
| 4                                 | Conclusions                                | 20%          |
| 5                                 | Practical related questions                | 20%          |
| <b>Total</b>                      |  | <b>100 %</b> |

| Marks Obtained          |                      |            | Dated signature of<br>Teacher |
|-------------------------|----------------------|------------|-------------------------------|
| Process Related<br>(15) | Product Related (10) | Total (25) |                               |
|                         |                      |            |                               |

## Practical No. 05

### Development of Ladder diagram and program PLC for two-way switch logic for staircase lighting

#### I. Practical Significance

Learn to build circuit for staircase lighting system and generate ladder diagram for the same and test by using PLC.

#### II. Industry/Employer Expected Outcome (s)

This practical is expected to develop the following skills for the industry/Employer.

- Prepare a program for PLC to run required output.

#### III. Course Level Learning Outcome (CO)

CO1. Identify basic elements of mechatronics system such as sensors, actuators, controllers etc.

CO2. Use sensors for different mechatronics systems.

CO3. Use actuators for different mechatronics systems..

#### IV. Laboratory Learning Outcome(s)

LLO5.1 Develop ladder diagram for staircase lighting.

LLO5.2 Execute PLC program for staircase lighting.

#### V. Relative Affective Domain Related Outcome(s)-

- Follow safety practices.
- Practice good housekeeping.
- Demonstrate working as a leader/a team member.
- Maintain electronics devices and equipment.
- Follow ethical Practices.

#### VI. Minimum Theoretical Background with diagram

Knowledge of Lighting control principles involve various strategies to manage and regulate lighting systems efficiently should be gained by student. Here's a breakdown of the principles mentioned:

1. On/Off control: This is the simplest form of lighting control, where lights are turned either on or off manually or automatically.

2. Dimming: Dimming involves adjusting the light output to a level lower than maximum capacity. This can be done manually or automatically to conserve energy, create ambiance, or prolong lamp life.

3. Timers and scheduling: This principle involves programming lighting systems to turn on/off or dim at specific times of the day, week, or year. Timers can be used to simulate occupancy, enhance security, or optimize energy usage.

4. Occupancy-based control: This principle uses sensors to detect human presence and adjust lighting accordingly. When a space is unoccupied, lights can be turned off or dimmed to save energy. Occupancy-based control can be achieved through various sensing technologies, such as:

- Passive infrared (PIR) sensors
- Ultrasonic sensors
- Motion sensors
- Light sensors (photodiodes or photocells)

**VII. Experimental setup (Model)-**

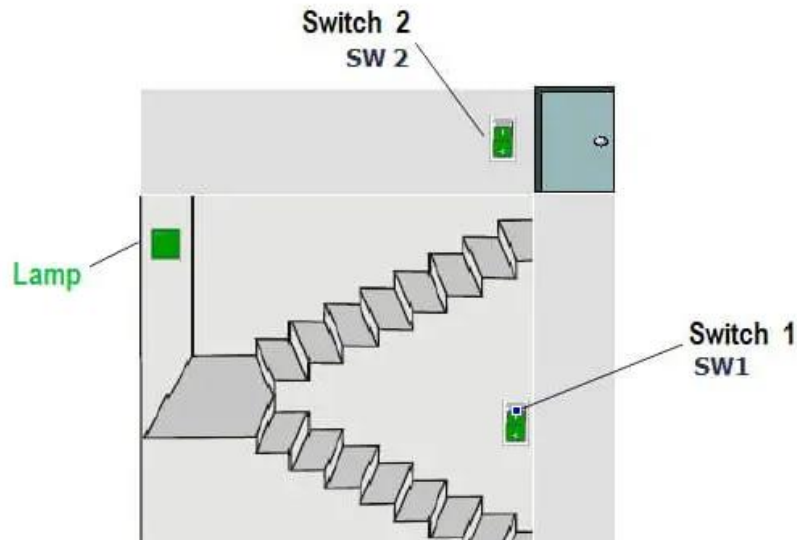

**Fig. 5.1: Concept of staircase lightening**

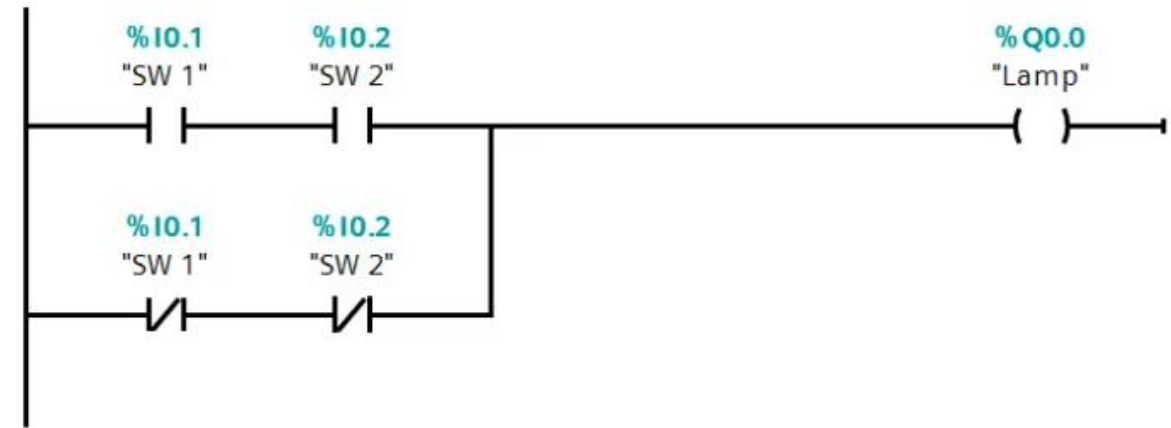

**Fig. 5.2: Two switch logic ladder diagram.**

**VIII. Required Resources /Apparatus/Equipment with specification**

| Sr. No. | Name of Resource              | Suggested Broad Specification  | Quantity |
|---------|-------------------------------|--|----------|
| 1       | Programmable logic controller | Digital input: 12 nos. with toggle switches for applying 24V dc inputs.<br>Digital Outputs:-12 Nos with 24V operated Lamp.<br>Analog Inputs: - 02<br>Analog Outputs: - 02<br>External Power Supply: 24 V DC.<br>Memory:-16 K data memory +351K Code Memory +96K upload Memory. | 01       |

| Sr. No. | Name of Resource | Suggested Broad Specification   | Quantity |
|---------|------------------|---|----------|
| 2       | Computer/Laptop  | PC preloaded with required PLC software and I/O communication facility. | 01       |

**IX. Precautions to be Followed**

- Due safety precautions to be taken while using PLC.

**X. Procedure**

1. For this application, we used S7-1200 PLC and TIA portal software for programming.
2. In above program, we have added two NO contacts of SW 1 (I0.1) and SW 2 (I0.2) in series and NC contacts of SW1 (I0.1) and SW2 (I0.2) in parallel of this series SW1 & SW2 NO Contacts.
3. If the status of the bottom switch (SW1) and status of the top switch (SW2) are same then lamp will be ON. And if either status of the bottom or top switch is different from other then lamp (Q0.0) will be OFF.
4. When lamp (Q0.0) is OFF then user can ON the lamp by changing status of any switch. Also user can turn OFF the lamp by changing the status of one of the two switches.

**XI. Observations and calculations –**

| Inputs            | Outputs | Physical Elements |
|-------------------|---------|-------------------|
| I 0.1=1 & I 0.2=1 | Q 0.0=1 | Lamp on           |
| I 0.1=0 & I 0.2=0 | Q 0.1=1 | Lamp on           |
| I 0.1=0 & I 0.2=1 | Q 0.1=0 | Lamp off          |
| I 0.1=1 & I 0.2=0 | Q 0.1=0 | Lamp off          |

**XII. Results**

| Inputs | Outputs | Physical Elements |
|--------|---------|-------------------|
|        |         |                   |
|        |         |                   |
|        |         |                   |
|        |         |                   |

**XIII. Interpretation of Results**

-----

-----

-----

-----

-----

**XIV. Conclusions and Recommendation**

-----  
-----  
-----  
-----  
-----  
-----

**XV. Practical Related Questions**

*Note: Below given are few sample questions for reference. Teachers must design more such questions so as to ensure the achievement of identified CO.*

1. Draw ladder diagram for any application similar to staircase light.
2. How does a staircase lighting circuit work?

**[Space for Answer]**

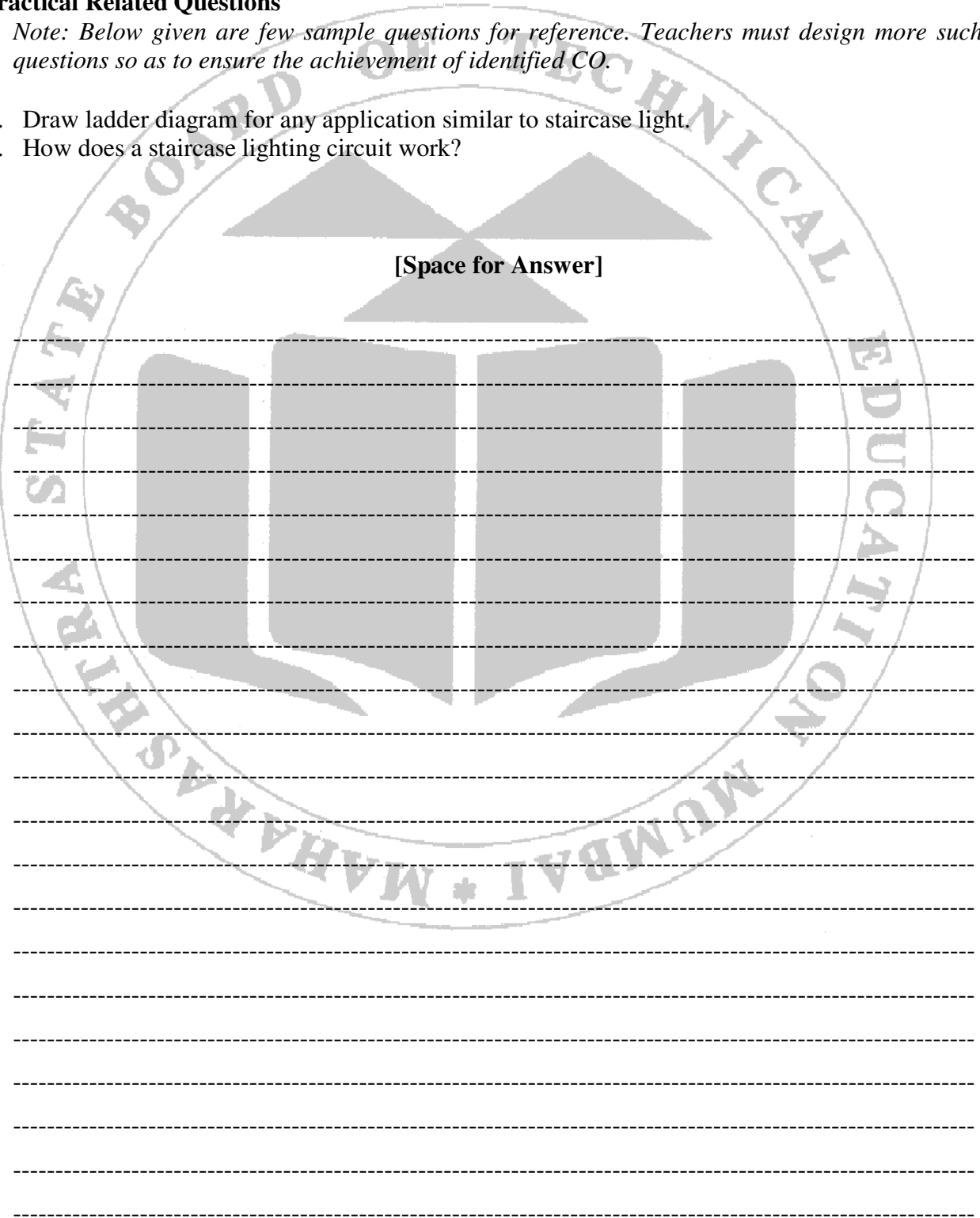

-----

-----

-----

-----

-----

-----

-----

-----

**XVI. References / Suggestions for Further Reading**

1. <https://da-iitb.vlabs.ac.in/exp/staircase-light-control/theory.html>
2. <https://www.youtube.com/watch?v=XGXLpVJqjOY>

**XVII Rubrics for Assessment Scheme**

| <b>Performance Indicators</b>     |  | <b>Weightage</b> |
|-----------------------------------|--|------------------|
| <b>Process Related (15 Marks)</b> |  | <b>(20%)</b>     |
| 1                                 | Handling of the measuring Instruments      | 10%              |
| 2                                 | Observations/Calculation of final readings | 10%              |
| <b>Product Related (10 Marks)</b> |  | <b>(80%)</b>     |
| 3                                 | Interpretation of result                   | 40%              |
| 4                                 | Conclusions                                | 20%              |
| 5                                 | Practical related questions                | 20%              |
| <b>Total</b>                      |  | <b>100 %</b>     |

| <b>Marks Obtained</b>       |                             |                   | <b>Dated signature of Teacher</b> |
|-----------------------------|-----------------------------|-------------------|-----------------------------------|
| <b>Process Related (15)</b> | <b>Product Related (10)</b> | <b>Total (25)</b> |                                   |
|                             |                             |                   |                                   |

## Practical No. 06

### Development of Ladder diagram and program PLC for Timers and Counters

#### I. Practical Significance

Many of the industrial processes require a needed action in particular time while in certain applications it is needed to count the number of times an event occurs like the number of times a part passes a certain point on a conveyor system.

#### II. Industry/Employer Expected Outcome (s)

This practical is expected to develop the following skills for the industry/Employer.

- Prepare a program for PLC to run required output.

#### III. Course Level Learning Outcome (CO)

CO4. Develop PLC program for various mechatronics systems.

#### IV. Laboratory Learning Outcome(s)

LLO 6.1. Develop ladder diagram for Timers and counters

LLO 6.2. Execute PLC program for Timers and counters

#### V. Relative Affective Domain Related Outcome(s)-

- Follow safety practices.
- Demonstrate working as a leader/a team member.
- Maintain tools and equipment.
- Follow ethical Practices.

#### VI. Minimum Theoretical Background with diagram

Timers find applications in tasks which involve time delay while counter is used for event counting.

PLC Timers:

PLC timers offer several advantages over their mechanical and electronic counterparts. In general, there are three different PLC timer types: the on-delay timer (TON), off-delay timer (TOF), and retentive timer on (RTO). The most common is the on-delay timer, which is the basic function. There are also many other timing configurations, all of which can be derived from one or more of the basic time-delay functions.

1. TON (Timer On Delay) - Counts time-based intervals when the instruction is true.
2. TOF (Timer Off Delay) - Counts time-based intervals when the instruction is false.
3. RTO (Retentive Timer On) - Counts time-based intervals when the instruction is true and retains the accumulated value when the instruction goes false or when power cycle occurs.
4. RES (Reset) -Resets a retentive timer's accumulated value to zero.

When programming timer address, timer base and preset value are specified by programmer.

1. Time Base- it is the multiplication factor of preset value of timer. Timers can be programmed with several different time bases: 1 s, 0.1 s, and 0.01 s are typical time bases. If a programmer entered 0.1 for the time base and 50 for the number of delay increments,

the timer would have a 5-s delay (50 3 0.1 s 5 5 s). The smaller the time base selected, the better the accuracy of the timer.

2. Preset Value-represents the time duration for the timing circuit. For example, if a time delay of 10 s is required, the timer will have a preset of 10 s.
3. Accumulator Value-represents the amount of time that has elapsed from the moment the timing coil became energized.

The Timer The control word uses the following three control bits:

1. Enable (EN) bit -The enable bit is true (has a status of 1) whenever the timer instruction is true. When the timer instruction is false, the enable bit is false (has a Status of 0).
2. Timer-timing (TT) bit -The timer-timing bit is true whenever the accumulated value of the timer is changing, which means the timer is timing. When the timer is not timing, the accumulated value is not changing, so the timer-timing bit is false.
3. Done (DN) bit -The done bit changes state whenever the accumulated value reaches the preset value. Its state depends on the type of timer being used.

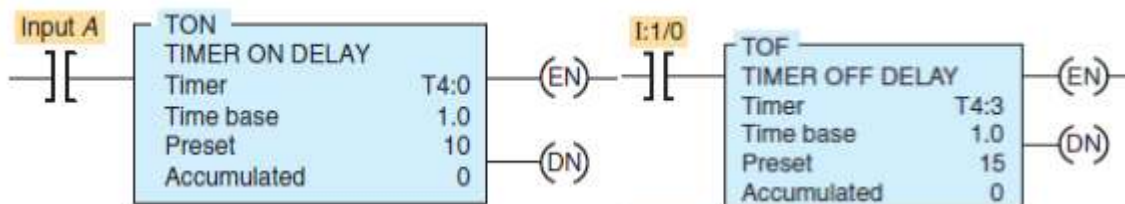

Fig 6.1: ON delay timer Instruction

Fig 6.2: OF Delay timer instruction

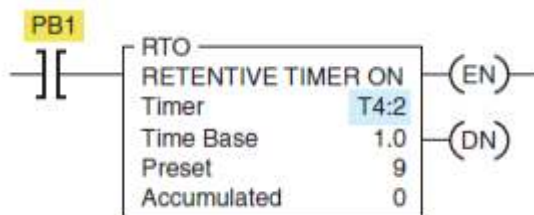

Fig 6.3: Retentive Timer instruction

**PLC Counters:**

The PLC counter instruction can be a countup or countdown. When a counter instruction is used in a program, the programmer must specify the count value and preset value. (Signed positive or negative integer).

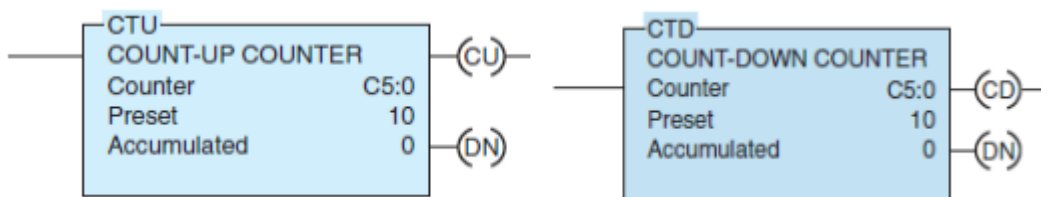
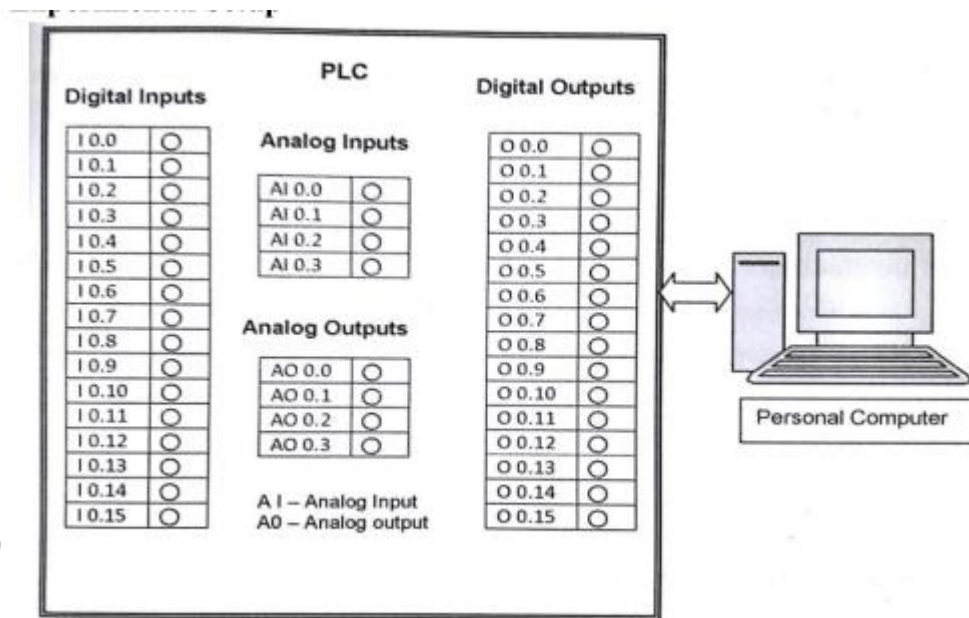

Fig 6.4: COUNT UP Counter Instruction

Fig 6.5: COUNT DOWN Counter Instruction

**VII. Experimental setup (Model)-**



**Fig 6.6: Experimental Set up**

**VIII. Required Resources /Apparatus/Equipment with specification**

| Sr. No. | Name of Resource              | Suggested Broad Specification  | Quantity |
|---------|-------------------------------|--|----------|
| 1       | Programmable logic controller | Digital input: 12 nos. with toggle switches for applying 24V dc inputs.<br>Digital Outputs:-12 Nos with 24V operated Lamp.<br>Analog Inputs: - 02<br>Analog Outputs: - 02<br>External Power Supply: 24 V DC.<br>Memory:-16 K data memory +351K Code Memory +96K upload Memory. | 01       |
| 2       | Computer/Laptop               | PC preloaded with required PLC software and I/O communication facility.  | 01       |

**IX. Precautions to be Followed**

- Due safety precaution should be taken while measuring angular speed.
- Avoid mishandling of Equipment.

**X. Procedure**

1. Open the PLC Software.
2. Create new project.
3. Develop ladder diagram for timer and counter application.
4. Test and correct the errors (if any).
5. Download the program on PLC.
6. Make required input output connections to PLC.
7. Execute the program and observe the output on hardware.
8. Repeat steps 3 to step 6 for different ON-OFF timings and counts.

**Ladder Diagram:**

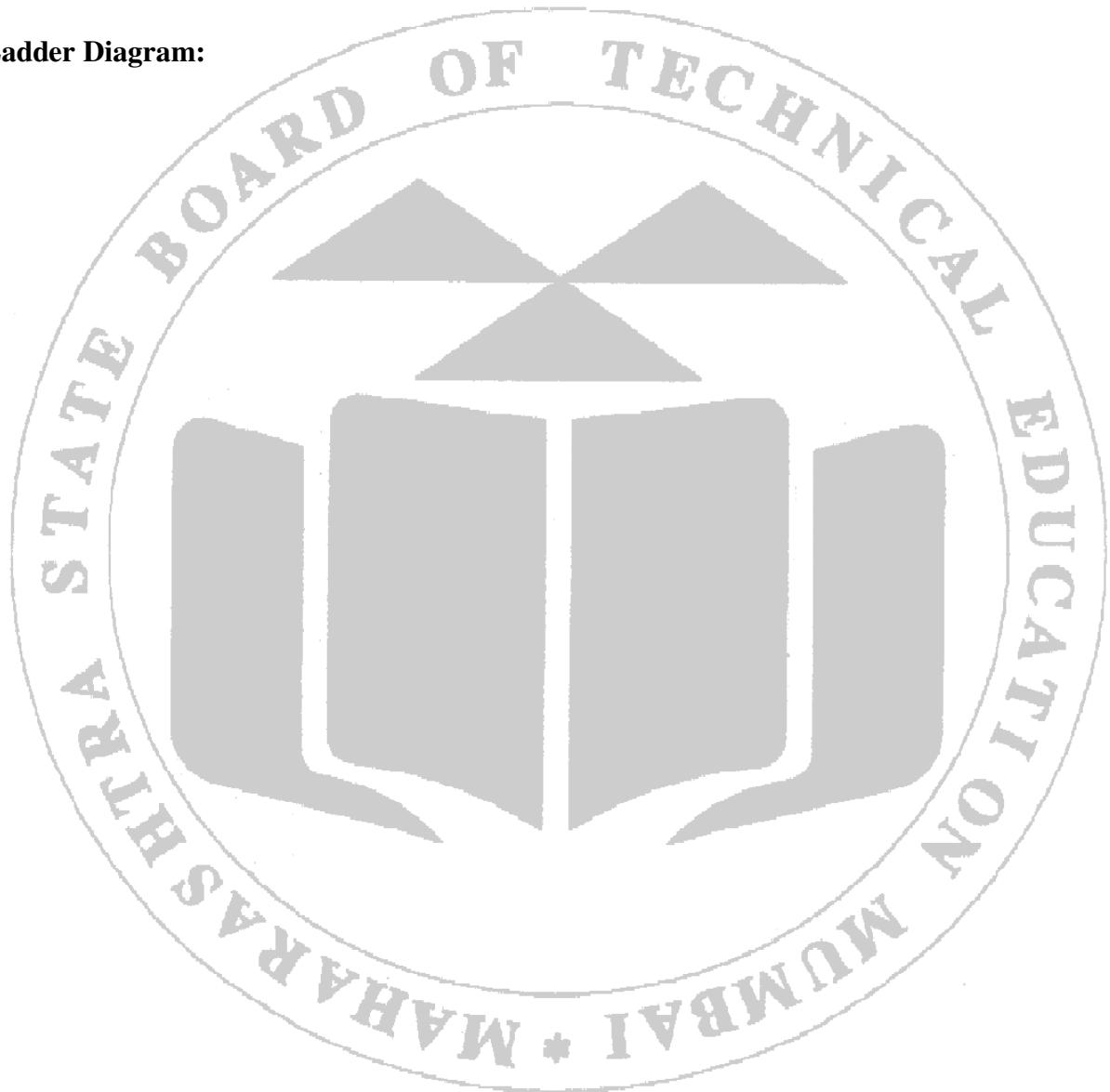

**XI. Observations and calculations –**

**Table 6.1: Observation table for Timer**

| Timer Delay in seconds | Base Value of Timer | Preset Value of Timer | Time Period of ON and OFF |
|------------------------|---------------------|-----------------------|---------------------------|
|                        |                     |                       |                           |
|                        |                     |                       |                           |
|                        |                     |                       |                           |

**Table 6.2: Observation table for Counter**

| Counter Count | Preset Value of Counter | Number of time the Lamp is ON/OFF | Time Period of ON and OFF |
|---------------|-------------------------|-----------------------------------|---------------------------|
|               |                         |                                   |                           |
|               |                         |                                   |                           |
|               |                         |                                   |                           |

**XII. Results**

-----

-----

-----

-----

**XIII. Interpretation of Results**

-----

-----

-----

-----

-----

**XIV. Conclusions and Recommendation**

-----

-----

-----

-----

-----

-----

**XV. Practical Related Questions**

*Note: Below given are few sample questions for reference. Teachers must design more such questions so as to ensure the achievement of identified CO.*

1. For a T ON timer
  - a) When is the enable bit of a timer instruction true?
  - b) When the timer-timing bit of a timer instruction is true?
  - c) When does the done bit of a timer change state?
2. Develop a ladder logic diagram to turn ON and OFF lamp after every 2 second for 4 times.
3. Design a PLC program that counts the number of times a pushbutton is closed.

[Space for Answer]

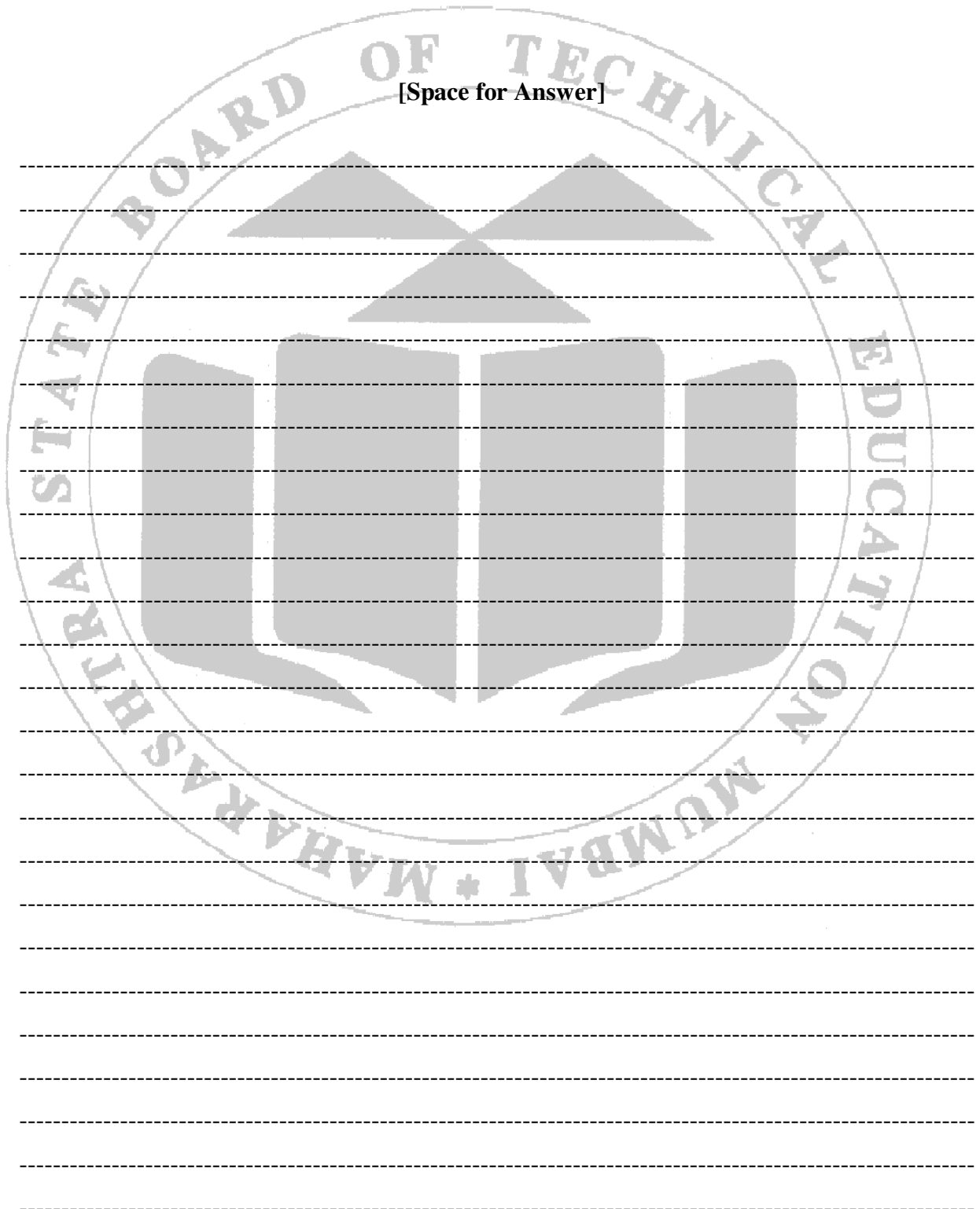

-----

-----

-----

-----

-----

-----

-----

-----

**XVI. References / Suggestions for Further Reading**

1. [https://www.youtube.com/watch?v=IRm\\_tB-irx8](https://www.youtube.com/watch?v=IRm_tB-irx8)
2. <https://www.youtube.com/watch?v=vPAmbEVjT1c>

**XVII Rubrics for Assessment Scheme**

| Performance Indicators            |  | Weightage    |
|-----------------------------------|--|--------------|
| <b>Process Related (15 Marks)</b> |  | <b>(20%)</b> |
| 1                                 | Handling of the measuring Instruments      | 10%          |
| 2                                 | Observations/Calculation of final readings | 10%          |
| <b>Product Related (10 Marks)</b> |  | <b>(80%)</b> |
| 3                                 | Interpretation of result                   | 40%          |
| 4                                 | Conclusions                                | 20%          |
| 5                                 | Practical related questions                | 20%          |
| <b>Total</b>                      |  | <b>100 %</b> |

| Marks Obtained       |                      |            | Dated signature of Teacher |
|----------------------|----------------------|------------|----------------------------|
| Process Related (15) | Product Related (10) | Total (25) |                            |
|                      |                      |            |                            |

## Practical No. 07

### Development of Ladder diagrams and program PLC for water level control.

#### I. Practical Significance

Programming the PLC and its hardware interfacing is the most essential requirement in the mechatronics industry. The students should be able to develop the logic for the given problem statement which can be implemented in industrial environment.

#### II. Industry/Employer Expected Outcome (s)

This practical is expected to develop the following skills for the industry/Employer.

- Select suitable actuator for given mechatronics system.
- Prepare a program for PLC to run required output.

#### III. Course Level Learning Outcome (CO)

- CO1. Identify basic elements of mechatronics system such as sensors, actuators, controllers etc.
- CO2. Use sensors for different mechatronics systems.
- CO3. Use actuators for different mechatronics systems.
- CO4. Develop PLC program for various mechatronics systems.

#### IV. Laboratory Learning Outcome(s)

LLO 7.1. Develop ladder diagram for water level control

LLO 7.2. Execute PLC program for water level control

#### V. Relative Affective Domain Related Outcome(s)-

- Follow safety practices.
- Demonstrate working as a leader/a team member.
- Maintain tools and equipment.
- Follow ethical Practices.

#### VI. Minimum Theoretical Background with diagram (if required)

Programming the PLC and its hardware interfacing is the most essential requirement in the mechatronics industry. The students should be able to develop the logic for the given problem statement which can be implemented in industrial environment.

#### VII. Experimental setup (Model)-

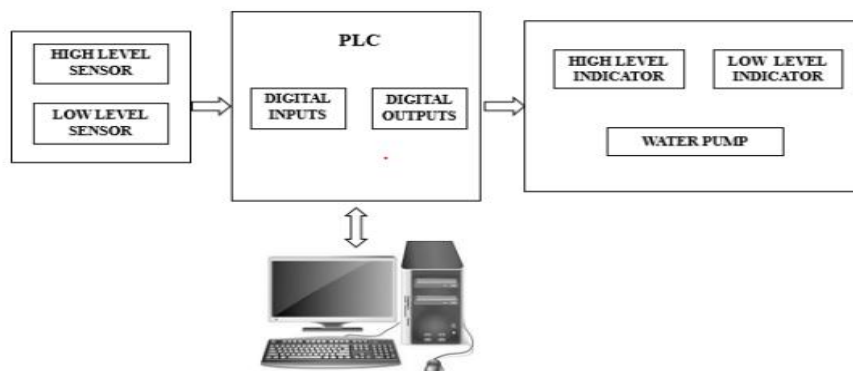

Fig 7.1: Experimental set up of water level control.

**VIII. Required Resources /Apparatus/Equipment with specification**

| Sr. No. | Name of Resource              | Suggested Broad Specification  | Quantity |
|---------|-------------------------------|--|----------|
| 1       | Programmable logic controller | Digital input: 12 nos. with toggle switches for applying 24V dc inputs.<br>Digital Outputs:-12 Nos with 24V operated Lamp.<br>Analog Inputs: - 02<br>Analog Outputs: - 02<br>External Power Supply: 24 V DC.<br>Memory:-16 K data memory +351K Code Memory +96K upload Memory. | 01       |
| 2       | Computer/Laptop               | PC preloaded with required PLC software and I/O communication facility.  | 01       |
| 3       | Tank Level Controller Module  | Tank Level Controller Module with facility to sense, indicate and control the High and Low level.  | 01       |

**IX. Precautions to be Followed**

- Safety precautions should be taken while making connections.
- Avoid improper handling of the equipment's.

**X. Procedure**

1. Open the PLC Software.
2. Create new project.
3. Develop ladder diagram for tank level controller.
4. Test and correct the errors (if any).
5. Download the program on PLC.
6. Make required input output connections to PLC.
7. Execute the program and observe the output on hardware.

**Ladder Diagram:**

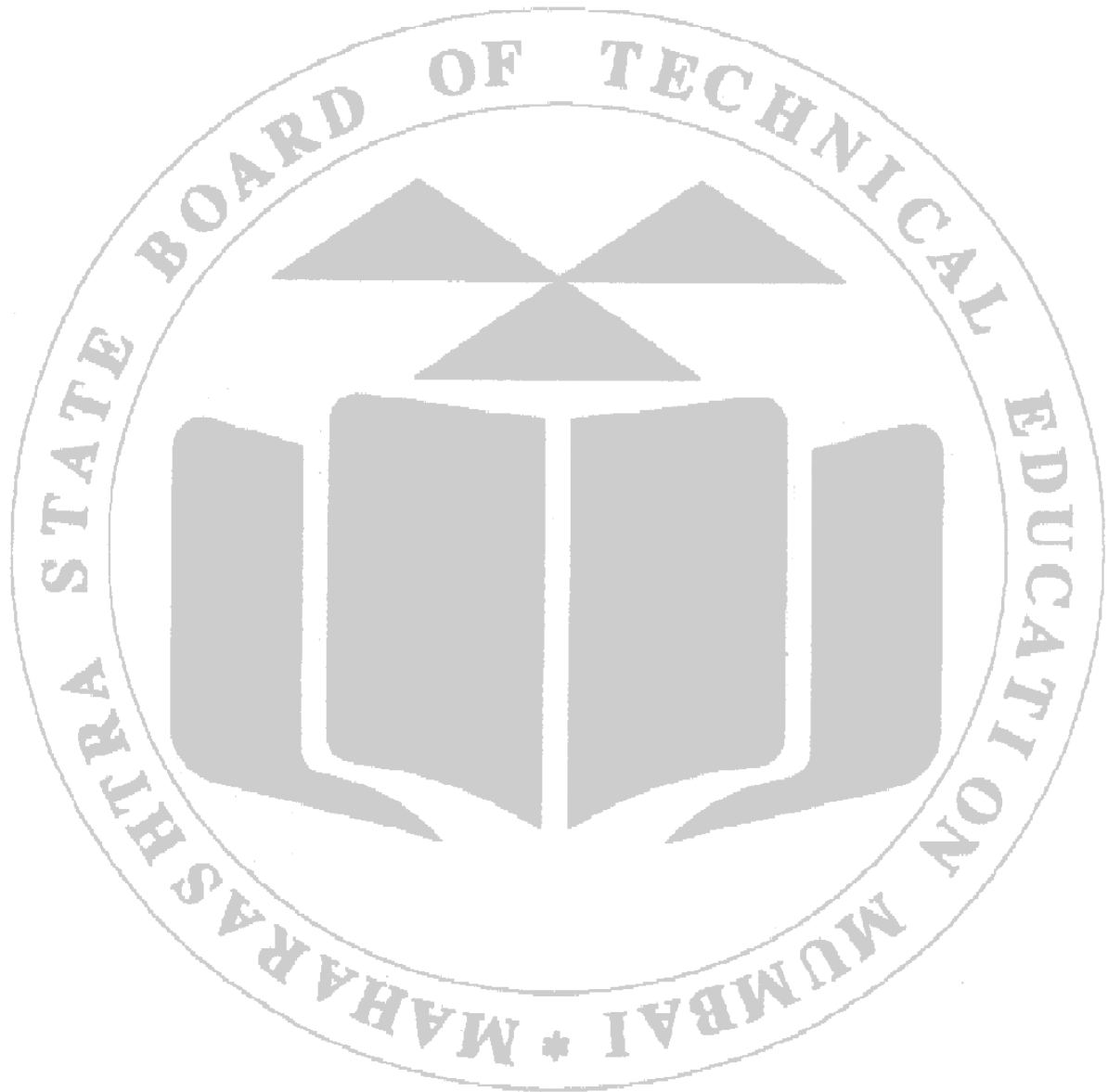

**XI. Resources Used:**

| Sr. No. | Name of Resource | Suggested Broad Specification | Quantity |
|---------|------------------|-------------------------------|----------|
|         |                  |                               |          |
|         |                  |                               |          |
|         |                  |                               |          |

**XII. Observations and calculations –**

| Step | Level of the tank | Status of the Level indicator | Action to be taken on Motor (ON/OFF) |
|------|-------------------|-------------------------------|--------------------------------------|
| 1    | Low               |                               |                                      |
|      | Medium            |                               |                                      |
|      | High              |                               |                                      |
| 2    | Low               |                               |                                      |
|      | Medium            |                               |                                      |
|      | High              |                               |                                      |

**XIII. Results**

.....  
.....  
.....  
.....

**XIV. Interpretation of Results**

.....  
.....  
.....  
.....

**XV. Conclusions and Recommendation**

.....  
.....  
.....  
.....  
.....

**XVI. Practical Related Questions**

*Note: Below given are few sample questions for reference. Teachers must design more such questions so as to ensure the achievement of identified CO.*

1. Which sensor used for sensing the water level? Explain its construction and working with diagram.
2. State any three other applications where such sensor can be used.

**[Space for Answer]**

.....  
.....  
.....  
.....  
.....  
.....  
.....  
.....  
.....

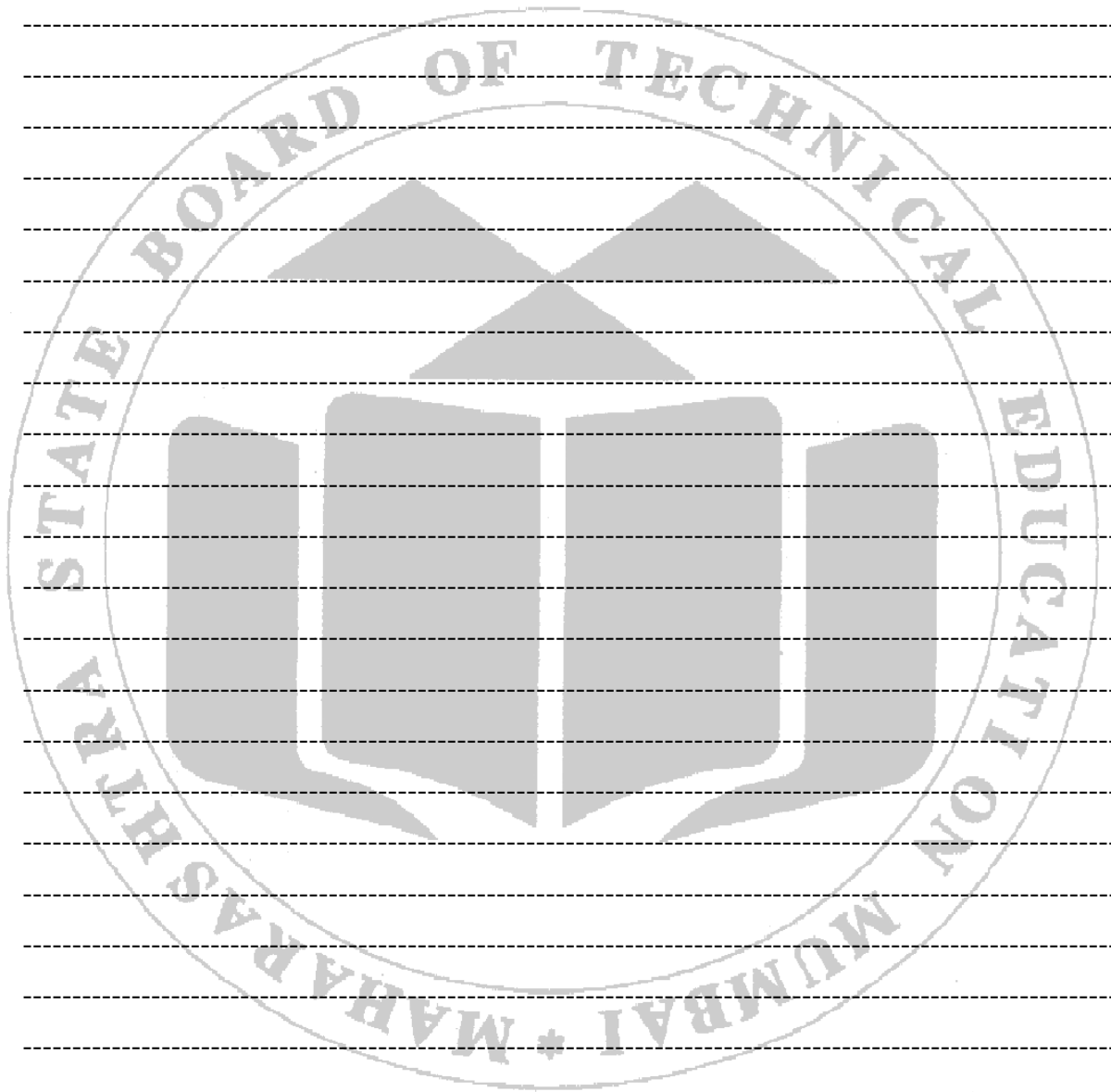

-----

-----

-----

-----

-----

-----

-----

**XVII. References / Suggestions for Further Reading**

1. <https://www.youtube.com/watch?v=qQoHQ0b-d1U>
2. <https://www.youtube.com/watch?v=CM6DntkoYyQ>

**XVIII. Rubrics for Assessment Scheme**

| Performance Indicators            |  | Weightage    |
|-----------------------------------|--|--------------|
| <b>Process Related (15 Marks)</b> |  | <b>(40%)</b> |
| 1                                 | Handling of the measuring Instruments      | 20%          |
| 2                                 | Observations/Calculation of final readings | 20%          |
| <b>Product Related (10 Marks)</b> |  | <b>(60%)</b> |
| 3                                 | Interpretation of result                   | 20%          |
| 4                                 | Conclusions                                | 20%          |
| 5                                 | Practical related questions                | 20%          |
| <b>Total</b>                      |  | <b>100 %</b> |

| Marks Obtained       |                      |            | Dated signature of Teacher |
|----------------------|----------------------|------------|----------------------------|
| Process Related (15) | Product Related (10) | Total (25) |                            |
|                      |                      |            |                            |

## Practical No.8

### Development of Ladder diagram and program PLC for pedestrian light (green/red) toggle control

#### I. Practical Significance

There are some tasks which require time delaying. This requirement can be met with timer feature available in PLCs. The knowledge of Timer is essential when it comes to turn on and off certain processes or components with required delay.

#### II. Industry/Employer Expected Outcome (s)

- a. Select suitable actuator for given mechatronics system.
- b. Prepare a program for PLC to run required output.

#### III. Course Level Learning Outcome (CO)

- CO1. Identify basic elements of mechatronics system such as sensors, actuators, controllers etc.
- CO2. Use sensors for different mechatronics systems.
- CO3. Use actuators for different mechatronics systems.
- CO4. Develop PLC programs for various mechatronics systems.

#### IV. Laboratory Learning Outcome(s)

- LLO 8.1 Develop ladder diagram for pedestrian light on off control  
LLO 8.2 Execute PLC program for pedestrian light on off control

#### V. Relative Affective Domain related Outcome(s)-

- Demonstrate working as a leader/a team member.
- Maintain tools and equipment.
- Follow ethical Practices.

#### VI. Minimum Theoretical Background with diagram

PLC supports the use of timers. Three different PLC timer types are- On-delay timer (TON), Off-delay timer (TOF), and Retentive timer on (RTO).

#### VII. Experimental setup

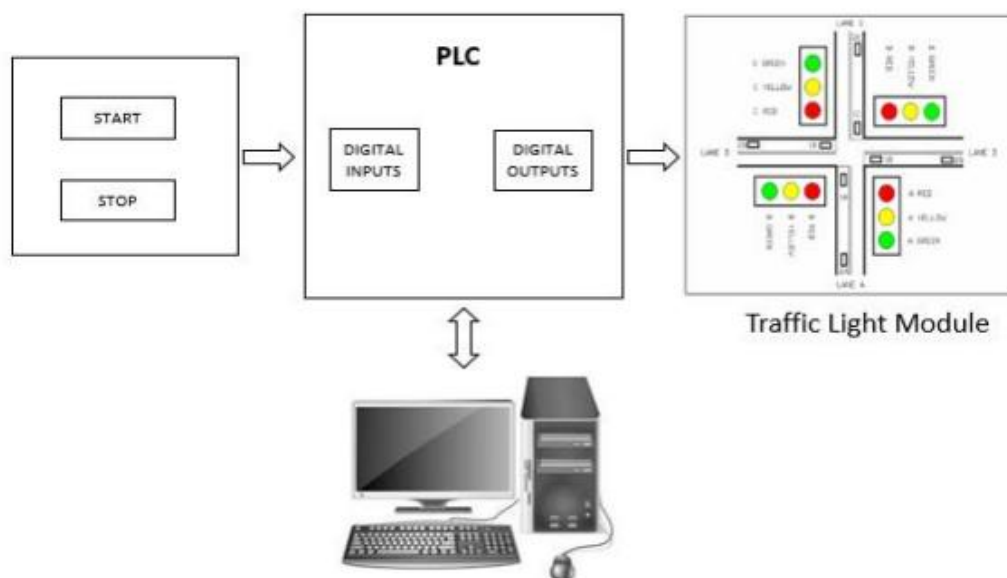

**Fig 8.1: Experimental Set up for pedestrian light control**

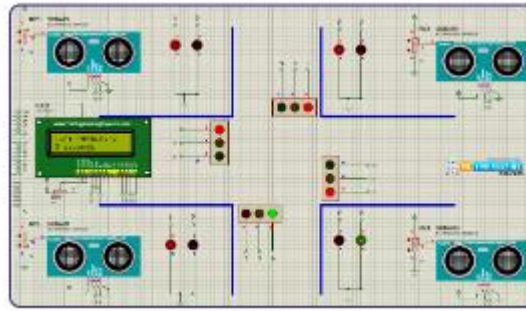

Fig 8.2: Sample traffic light control module

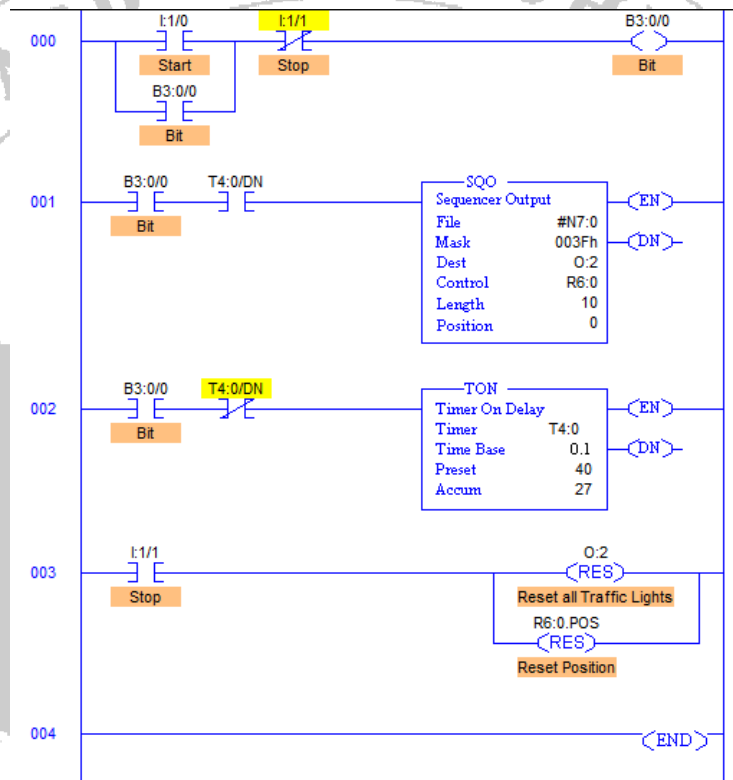

Fig 8.3: sample ladder logic

**VIII. Required Resources /Apparatus/Equipment with specification**

| Sr. No. | Name of Resource              | Suggested Broad Specification  | Quantity |
|---------|-------------------------------|--|----------|
| 1       | Programmable logic controller | Digital input: 12 nos. with toggle switches for applying 24V dc inputs.<br>Digital Outputs:-12 Nos with 24V operated Lamp.<br>Analog Inputs: - 02<br>Analog Outputs: - 02<br>External Power Supply: 24 V DC.<br>Memory:-16 K data memory +351K Code Memory +96K upload Memory. | 01       |

| Sr. No. | Name of Resource     | Suggested Broad Specification   | Quantity |
|---------|----------------------|---|----------|
| 2       | Computer/Laptop      | PC preloaded with required PLC software and I/O communication facility. | 01       |
| 3       | Traffic light Module | Four way junction module  | 01       |

**IX. Precautions to be Followed**

1. Avoid improper handling of instrument.
2. Follow safety practices about maintaining tools and equipment.

**X. Procedure**

1. Open the PLC Software.
2. Create new project.
3. Develop ladder diagram for pedestrian traffic controller.
4. Test and correct the errors (if any).
5. Download the program on PLC.
6. Connect traffic light module with PLC.
7. Execute the program.
8. Repeat steps 3 to step 7 for different ON and OFF timings.

**XI. Resources Used:**

| Sr. No. | Name of Resource | Suggested Broad Specification | Quantity |
|---------|------------------|-------------------------------|----------|
|         |                  |                               |          |
|         |                  |                               |          |
|         |                  |                               |          |

| Sr. No. | Name of Resource | Suggested Broad Specification | Quantity |
|---------|------------------|-------------------------------|----------|
|         |                  |                               |          |

**XII. Observations and calculations**

**Table 8.1:** Measurement of Signal Timings

| Step | Signal | Signal Timings in Seconds |        |        |        |
|------|--------|---------------------------|--------|--------|--------|
|      |        | Lane A                    | Lane B | Lane C | Lane D |
| 1    | Red    |                           |        |        |        |
|      | Green  |                           |        |        |        |
| 2    | Red    |                           |        |        |        |
|      | Green  |                           |        |        |        |
| 3    | Red    |                           |        |        |        |
|      | Green  |                           |        |        |        |
| 4    | Red    |                           |        |        |        |
|      | Green  |                           |        |        |        |

**XIII. Results**

-----

-----

-----

-----

**XIV. Interpretation of Results**

-----

-----

-----

-----



-----

-----

-----

-----

-----

-----

-----

-----

-----

-----

-----

-----

-----

-----

-----

-----

-----

-----

-----

-----

**XVII. References / Suggestions for Further Reading**

1. <https://www.youtube.com/watch?v=WEKJir5Ly80>
2. <https://www.youtube.com/watch?v=mFSuzfGuTHk>

**XVII Rubrics for Assessment Scheme**

| Performance Indicators            |   | Weightage    |
|-----------------------------------|---|--------------|
| <b>Process Related (15 Marks)</b> |   | <b>(20%)</b> |
| 1                                 | Use/Handling of the Drawing Instruments | 10%          |
| 2                                 | Correctness of profile drawn            | 10%          |
| <b>Product Related (10 Marks)</b> |   | <b>(80%)</b> |
| 3                                 | Interpretation of result                | 40%          |
| 4                                 | Conclusions                             | 20%          |
| 5                                 | Practical related questions             | 20%          |
| <b>Total</b>                      |   | <b>100 %</b> |

| Marks Obtained     |                     |            | Dated signature of Teacher |
|--------------------|---------------------|------------|----------------------------|
| Process Related(5) | Product Related(20) | Total (25) |                            |
|                    |                     |            |                            |

## Practical No. 9

### Development of Ladder diagram and program PLC for on/off Temperature Control

#### I Practical Significance

This experiment enables students to understand the practical application of Programmable Logic Controllers (PLC) in automated temperature control systems. This foundational knowledge is crucial in manufacturing, HVAC, and chemical processing industries, where temperature regulation is essential for product quality and safety.

#### II Industry / Employer Expected Outcome(s)

1. Ability to develop and implement PLC-based control systems for temperature regulation.
2. Familiarity with ladder logic programming for industrial automation.
3. Proficiency in configuring sensors and actuators in a control loop.

#### III Course Level Learning Outcome(s)

- CO1. Identify basic elements of mechatronics system such as sensors, actuators, controllers etc.
- CO2. Use sensors for different mechatronics systems.
- CO3. Use actuators for different mechatronics systems.
- CO4. Develop PLC program for various mechatronics systems.

#### IV Laboratory Learning Outcome(s)

LLO 9.1 Develop ladder diagram for temperature control

LLO 9.2 Execute PLC program for temperature control.

#### V Relevant Affective Domain-related Outcomes

1. Follow precautionary measures.
2. Demonstrate working as a leader/ team member.
3. Follow ethical practices

#### VI Relevant Theoretical Background

##### Temperature Sensors Overview:

**Thermistor:** A temperature-sensitive resistor whose resistance decreases as temperature increases (negative temperature coefficient) or increases as temperature increases (positive temperature coefficient). It is commonly used for precise temperature measurements in smaller ranges.

**Thermocouple:** Consists of two different metals joined at two points, generating a voltage that correlates with temperature differences between these points. The Seebeck effect governs this principle, and thermocouples are ideal for a wide range of temperature measurements.

**PT100 (Platinum RTD):** A platinum resistance temperature detector whose resistance is 100Ω at 0°C. The resistance increases linearly with temperature, making it highly accurate and suitable for industrial applications devices.

**VII Experimental Setup**

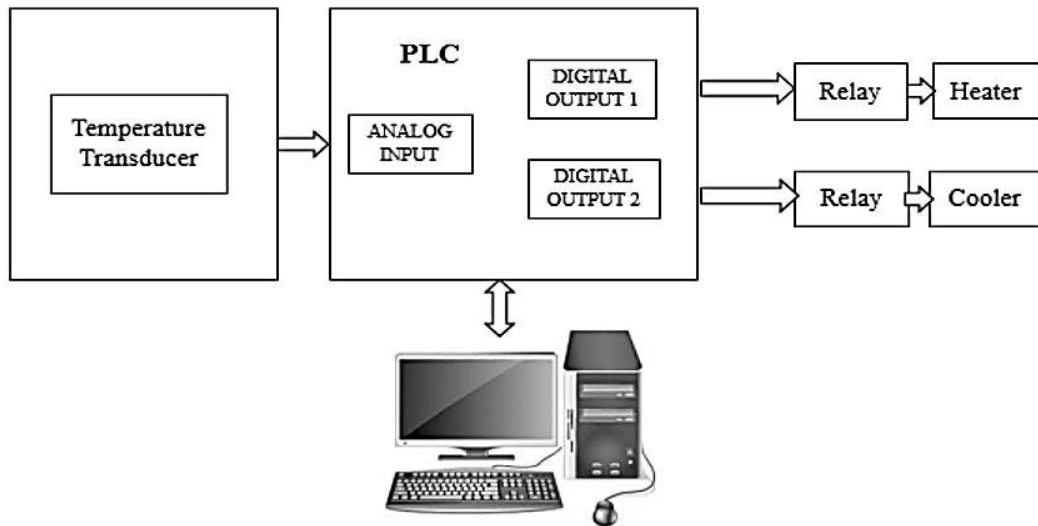

**Fig 9.1 Experimental setup for temperature control using PLC**

**VIII Required Resources/apparatus/equipment with specifications**

| Sr. No. | Name of Resource                            | Suggested Broad Specification  | Quantity |
|---------|---|--|----------|
| 1       | Computer/ Laptop                            | PC preloaded with PLC software and I/O communication facility  | 01       |
| 2       | Programmable Logic Controller (PLC) Trainer | <b>Digital Inputs:</b> -12 Nos with toggle switches for applying 24V DC inputs.<br><b>Digital Outputs:</b> -12 Nos with 24V operated Lamp.<br><b>Analog Inputs:</b> - 02<br><b>Analog Outputs:</b> - 02<br><b>External Power Supply:</b> 24 V DC.<br><b>Memory:</b> -16 K data memory +35 IK Code Memory +96K upload Memory. | 01       |
| 3       | Temperature Sensors and Actuator            | RTD (PT100), Thermocouple, Relays, Motor.  | 01       |

**IX Precautions to be followed**

1. Follow safety and operational guidelines while using the Laboratory.
2. Ensure proper handling of electronic components to prevent damage from static electricity.
3. Avoid direct contact with high temperatures; use tools or protective equipment as needed.
4. Follow manufacturer guidelines for wiring and installation of PLC and sensors.

**X Procedure**

1. Open PLC software.
2. Create a new project and develop a ladder diagram for temperature control using PLC.
3. Test and correct the error (If any).
4. Download the program on the PLC.
5. Connect the temperature sensor to the PLC input module at the input of heater and cooler at the output of the PLC.
6. Test the program by adjusting the temperature and observing the on/off relay response.
7. repeat 3 to 7 steps for different temperatures.
8. Open the PLC programming software and develop a ladder diagram for on/off temperature control.
9. Waste Management & Energy Saving: Ensure proper disposal of any electronic waste; switch off equipment when not in use.

**Ladder Diagram**

**XI Observation Table**

**Table 9.1 Measurement of Temperature.**

| Sr. No. | Value of Set Temperature | Temperature when the Heater is |     | Temperature when Cooler is |     |
|---------|--------------------------|--------------------------------|-----|----------------------------|-----|
|         |                          | ON                             | OFF | ON                         | OFF |
| 1       |                          |                                |     |                            |     |
| 2       |                          |                                |     |                            |     |
| 3       |                          |                                |     |                            |     |
| 4       |                          |                                |     |                            |     |
| 5       |                          |                                |     |                            |     |

**XII Result**

-----

-----

-----

-----

-----

-----

**XIII Interpretation of results**

-----

-----

-----

-----

-----

-----

**XIV Conclusion and recommendation**

-----

-----



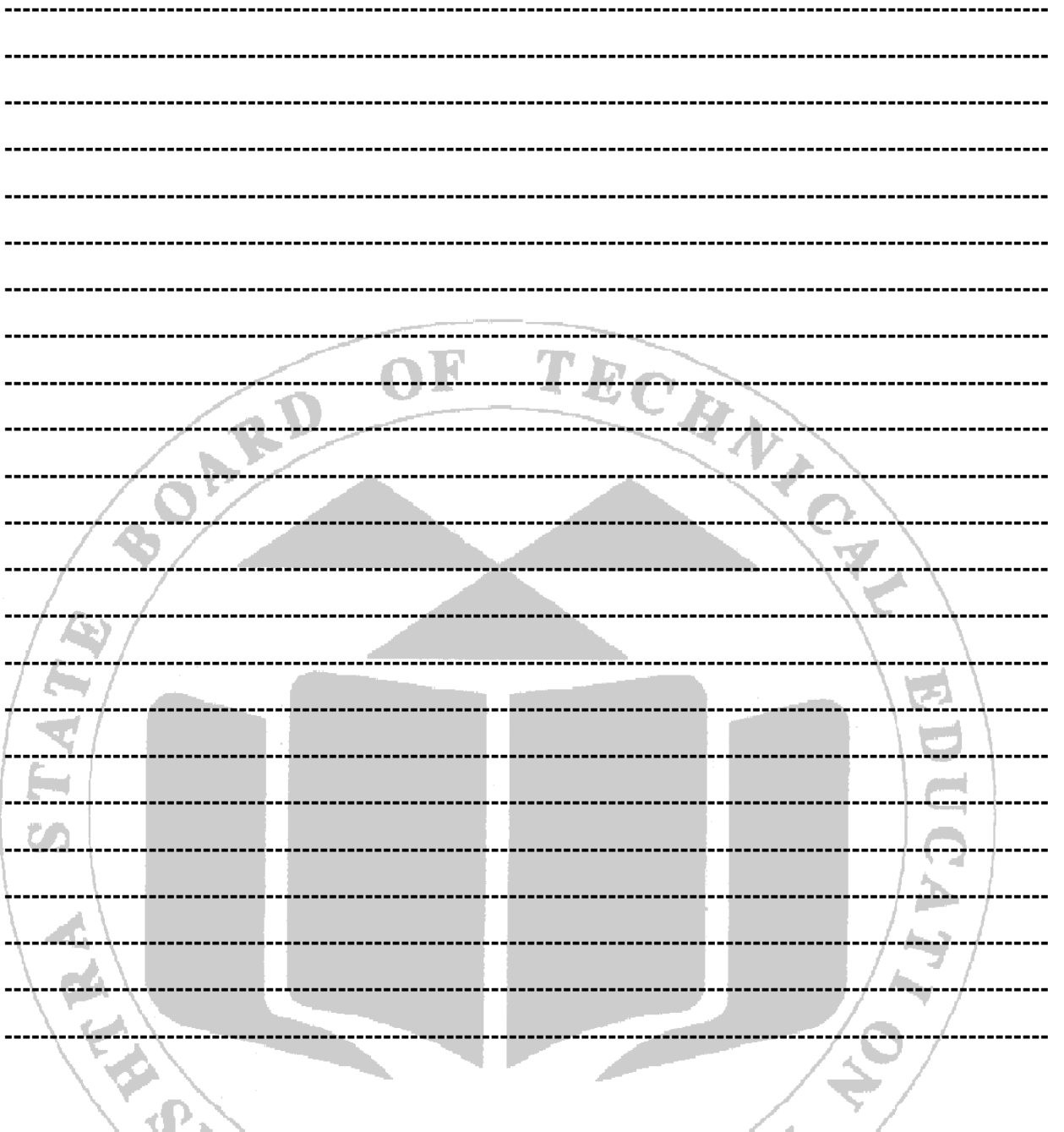

**XVI References/Suggestions for further reading**

1. <https://kmindustrialcorp.com/blog/all-about-temperature-sensors/>
2. <https://www.youtube.com/watch?v=TxqO94P4WnE>
3. <https://instrumentationtools.com/plc-program-temperature-control-using-thermostat/>
4. Programmable Logic Controllers by Frank D Petruzella.
5. Mechatronics by W. Bolton.

**XVII Rubrics for Assessment Scheme**

| <b>Performance Indicators</b>     |                                       | <b>Weightage</b> |
|-----------------------------------|---------------------------------------|------------------|
| <b>Process Related (15 Marks)</b> |                                       | <b>(60%)</b>     |
| 1.                                | Handling of the measuring Instruments | 30%              |
| 2.                                | Calculation of final readings         | 30%              |
| <b>Product Related (10 Marks)</b> |                                       | <b>(40%)</b>     |
| 3.                                | Interpretation of result              | 20%              |
| 4.                                | Conclusions                           | 10%              |
| 5.                                | Practical related questions           | 10%              |
| <b>Total ( 25 Marks)</b>          |                                       | <b>100 %</b>     |

| <b>Marks Obtained</b>           |                                 |                   | <b>Dated signature of Teacher</b> |
|---------------------------------|---------------------------------|-------------------|-----------------------------------|
| <b>Process Related<br/>(15)</b> | <b>Product Related<br/>(10)</b> | <b>Total (25)</b> |                                   |
|                                 |                                 |                   |                                   |

## Practical No. 10

### Development of Ladder diagram and program PLC for Lift/ Elevator control

#### I Practical Significance

This experiment introduces the automation of a lift/elevator system using a Programmable Logic Controller (PLC). Elevators are widely used in modern infrastructure, and automated control is crucial for safe and efficient operation. This practical equips students with the knowledge to design and implement PLC-based automation for similar real-world applications.

#### II Industry / Employer Expected Outcome(s)

1. Understanding the design of automated lift control systems.
2. Proficiency in writing and executing PLC programs for industrial applications.
3. Familiarity with safety protocols and operational logic required for elevator systems.

#### III Course Level Learning Outcome(s)

- CO1. Identify basic elements of mechatronics system such as sensors, actuators, controllers etc.
- CO2. Use sensors for different mechatronics systems.
- CO3. Use actuators for different mechatronics systems.
- CO4. Develop PLC program for various mechatronics systems.

#### IV Laboratory Learning Outcome(s)

LLO 10.1 Develop ladder diagram for lift/elevator control.

LLO 10.2 Execute PLC program for lift/elevator control.

#### V Relevant Affective Domain-related Outcomes

1. Follow precautionary measures.
2. Working collaboratively on complex automation projects.
3. Observing safety guidelines and protocols when designing control systems

#### VI Relevant Theoretical

##### Background

The lift/elevator control system involves the integration of sensors, actuators, and a control unit to automate the movement of the elevator. The PLC manages the elevator's operations, such as moving between floors, stopping at designated points, and opening/closing doors. The system uses limit switches or proximity sensors to detect the position of the elevator car, push buttons for floor selection, and actuators to drive the motor and control the doors.

- **Sensors:** Detect floor positions and open/close states of doors.
- **Actuators:** Operate the elevator motor and door mechanism.
- **PLC Logic:** Controls the sequence of operations based on input from sensors and commands from users.

**VII Experimental Setup**

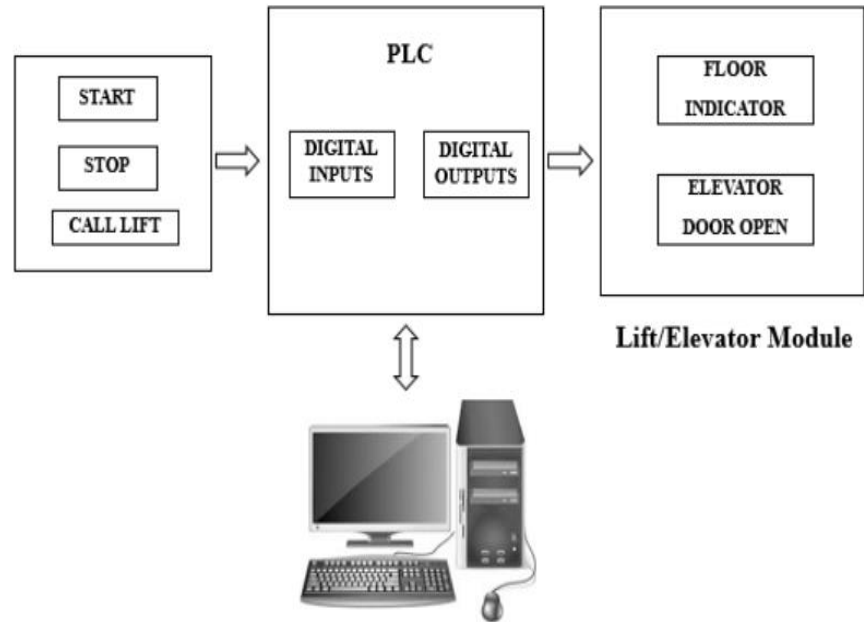

**Fig 10.1 Experimental setup for Lift / Elevator controller using PLC**

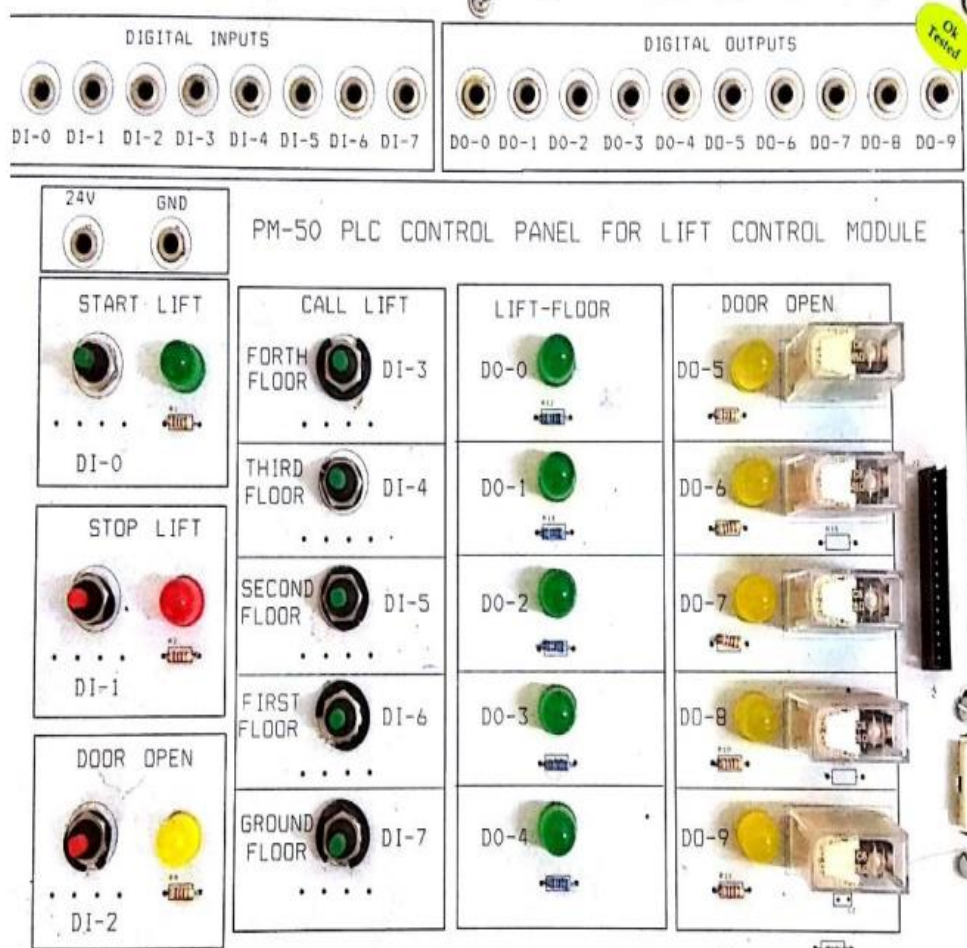

**Fig 10.2 Sample Lift / Elevator controller module.**

**VIII Required Resources/apparatus/equipment with specifications**

| Sr. No. | Name of Resource                            | Suggested Broad Specification  | Quantity |
|---------|---|--|----------|
| 1       | Computer/ Laptop                            | PC preloaded with PLC software and I/O communication facility  | 01       |
| 2       | Programmable Logic Controller (PLC) Trainer | <b>Digital Inputs:-</b> 12 Nos with toggle switches for applying 24V dc inputs.<br><b>Digital Outputs:-</b> 12 Nos with 24V operated Lamp.<br>Analog Inputs: - 02<br>Analog Outputs: - 02<br>External Power Supply: 24 V DC.<br>Memory:-16 K data memory +351K Code Memory +96K upload Memory. | 01       |
| 3       | Lift/Elevator Module                        | Lift/Elevator Module with facility to start, stop, call the lift and Visual Indication of Floor Number and Door open indication.   | 01       |

**IX Precautions to be followed**

1. Follow safety and operational guidelines while using the Laboratory.
2. Ensure proper handling of electronic components to prevent damage from static electricity.
3. Avoid direct contact with high temperatures; use tools or protective equipment as needed.
4. Follow manufacturer guidelines for wiring and installation of PLC and sensors.

**X Procedure**

1. Open PLC software.
2. Create a new project and develop a ladder diagram for Lift/Elevator controller.
3. Test and correct the error (If any).
4. Download the program on the PLC.
5. Connect the Lift/Elevator controller Module to the PLC and make required input-output connections.
6. Test the program by selecting the floor.
7. repeat 3 to 6 steps for the floor and condition.

## Ladder Diagram

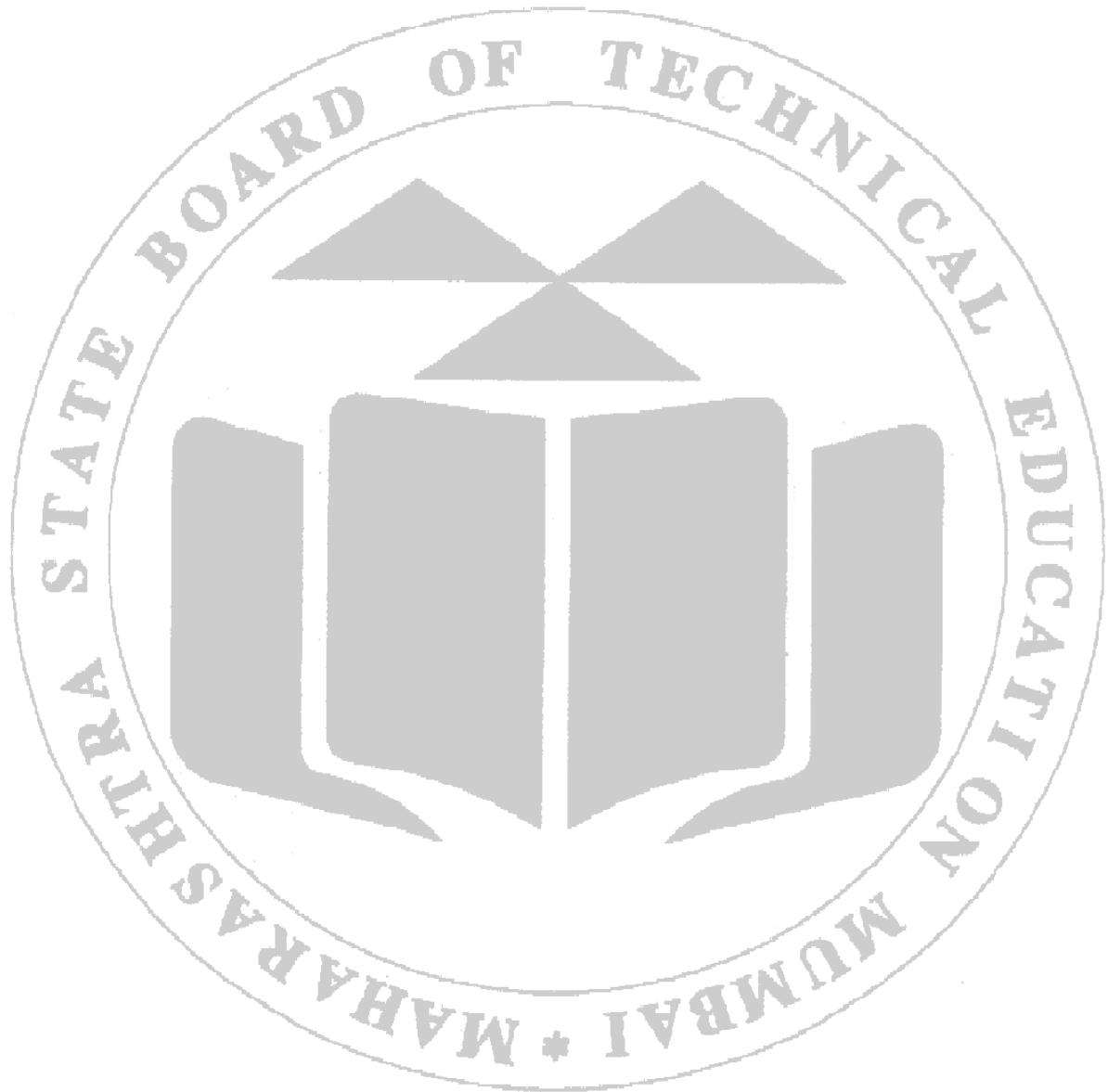

**XI Observation Table**

**Table 10.1 Measurement of Temperature.**

| Sr. No. | Floor Selected | Motor / Simulation Action (Up/Down/Stop) | Door Status (Open/Closed) | Sensor Status |
|---------|----------------|--|---------------------------|---------------|
| 1       |                |  |                           |               |
| 2       |                |  |                           |               |
| 3       |                |  |                           |               |
| 4       |                |  |                           |               |

**XII Result**

-----

-----

-----

-----

-----

**XIII Interpretation of results**

-----

-----

-----

-----

-----

**XIV Conclusion and recommendation**

-----

-----

-----

-----

**XV Practical related questions**

*Note: Below are a few sample questions for reference. Teachers must design more such questions so as to ensure the achievement of the identified CO.*

1. What are the essential safety features needed in an elevator control system?
2. How does the PLC ensure that the elevator doors are securely closed before moving?
3. Why is it important to use limit switches in an elevator system?
4. Explain the hardware changes needs to be made so as to increase the number of floors.
5. State the factors need to be considered so as to increase the Load Carrying capacity of the elevator

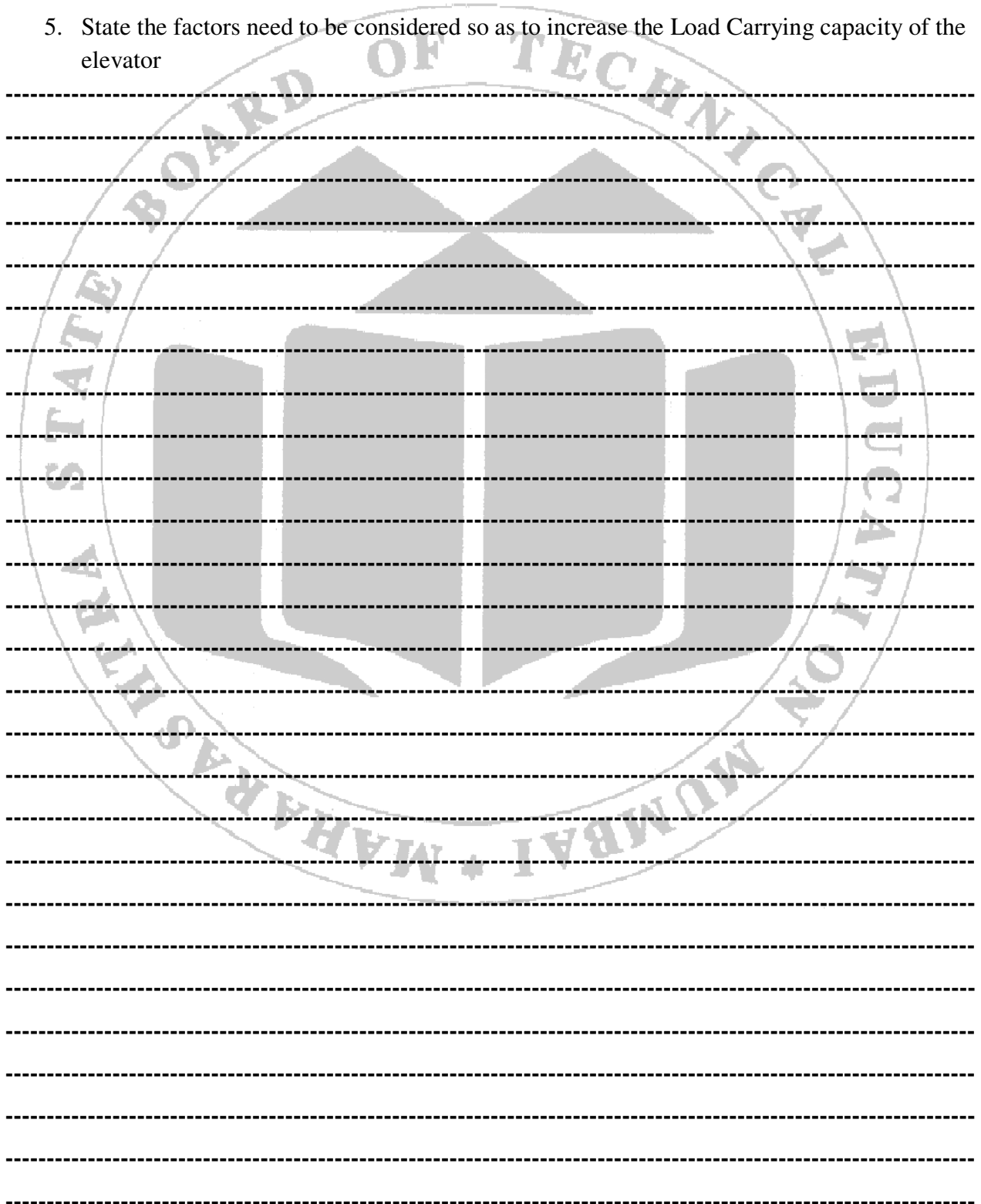

-----  
 -----  
 -----  
 -----

**References/Suggestions for further reading**

6. <https://instrumentationtools.com/elevator-plc-ladder-logic/>
7. <https://swiftlifts.com/hi/how-does-an-elevator-work/>
8. Programmable Logic Controllers by Frank D Petruzella.
9. Mechatronics by W. Bolton.

**XVI Rubrics for Assessment Scheme**

| Performance Indicators            |                                       | Weightage    |
|-----------------------------------|---------------------------------------|--------------|
| <b>Process Related (15 Marks)</b> |                                       | <b>(60%)</b> |
| 1.                                | Handling of the measuring Instruments | 30%          |
| 2.                                | Calculation of final readings         | 30%          |
| <b>Product Related (10 Marks)</b> |                                       | <b>(40%)</b> |
| 3.                                | Interpretation of result              | 20%          |
| 4.                                | Conclusions                           | 10%          |
| 5.                                | Practical related questions           | 10%          |
| <b>Total ( 25 Marks)</b>          |                                       | <b>100 %</b> |

| Marks Obtained          |                         |            | Dated signature of Teacher |
|-------------------------|-------------------------|------------|----------------------------|
| Process Related<br>(15) | Product Related<br>(10) | Total (25) |                            |
|                         |                         |            |                            |

## Practical No. 11: Development of Ladder diagram and program PLC for single acting/double acting pneumatic system

### I Practical Significance

The experiment introduces the design and implementation of ladder diagrams and PLC programming, essential for industrial automation. Pneumatic systems are widely used in industries for automation, making this a foundational skill for mechatronics professionals.

### II Industry / Employer Expected Outcome(s)

1. Ability to design and implement ladder logic for pneumatic control systems.
2. Competence in configuring PLCs to control single/double-acting pneumatic actuators.
3. Understanding of pneumatic system operations in real-world industrial automation scenarios.

### III Course Level Learning Outcome(s)

- CO1. Identify basic elements of mechatronics system such as sensors, actuators, controllers etc.
- CO2. Use sensors for different mechatronics systems.
- CO3. Use actuators for different mechatronics systems.
- CO4. Develop PLC program for various mechatronics systems.

### IV Laboratory Learning Outcome(s)

LLO 11.1: Develop ladder diagrams for single-acting/double-acting pneumatic systems.

LLO 11.2: Execute PLC programs for single-acting/double-acting pneumatic systems.

### V Relevant Affective Domain-related Outcomes

1. Follow precautionary measures.
2. Working collaboratively on complex automation projects.
3. Observing safety guidelines and protocols when designing control systems

### VI Relevant Theoretical Background

Pneumatics deals with the use of compressed air to perform mechanical work. It is a core technology in automation, particularly for tasks requiring linear or rotary motion. Pneumatic systems are energy-efficient, reliable, and relatively simple to maintain, making them a preferred choice in industrial automation.

#### Types of Pneumatic Actuators

##### 1. Single-Acting Cylinder (SAC):

- Operates using air pressure for one direction (extension).
- A spring mechanism retracts the cylinder when air pressure is released.
- Energy-efficient for operations requiring infrequent retraction.

##### 2. Double-Acting Cylinder (DAC):

- Requires air pressure for both extension and retraction.
- Provides greater control and is suitable for repetitive or continuous operations.

### 3. Solenoid Valves in Pneumatics

- Function: Controls the flow of compressed air into and out of actuators.
- Types:
  - i. 2/2-way valve: Allows control for single-acting cylinders.
  - ii. 5/2-way valve: Provides direction control for double-acting cylinders.

## VII Experimental Setup

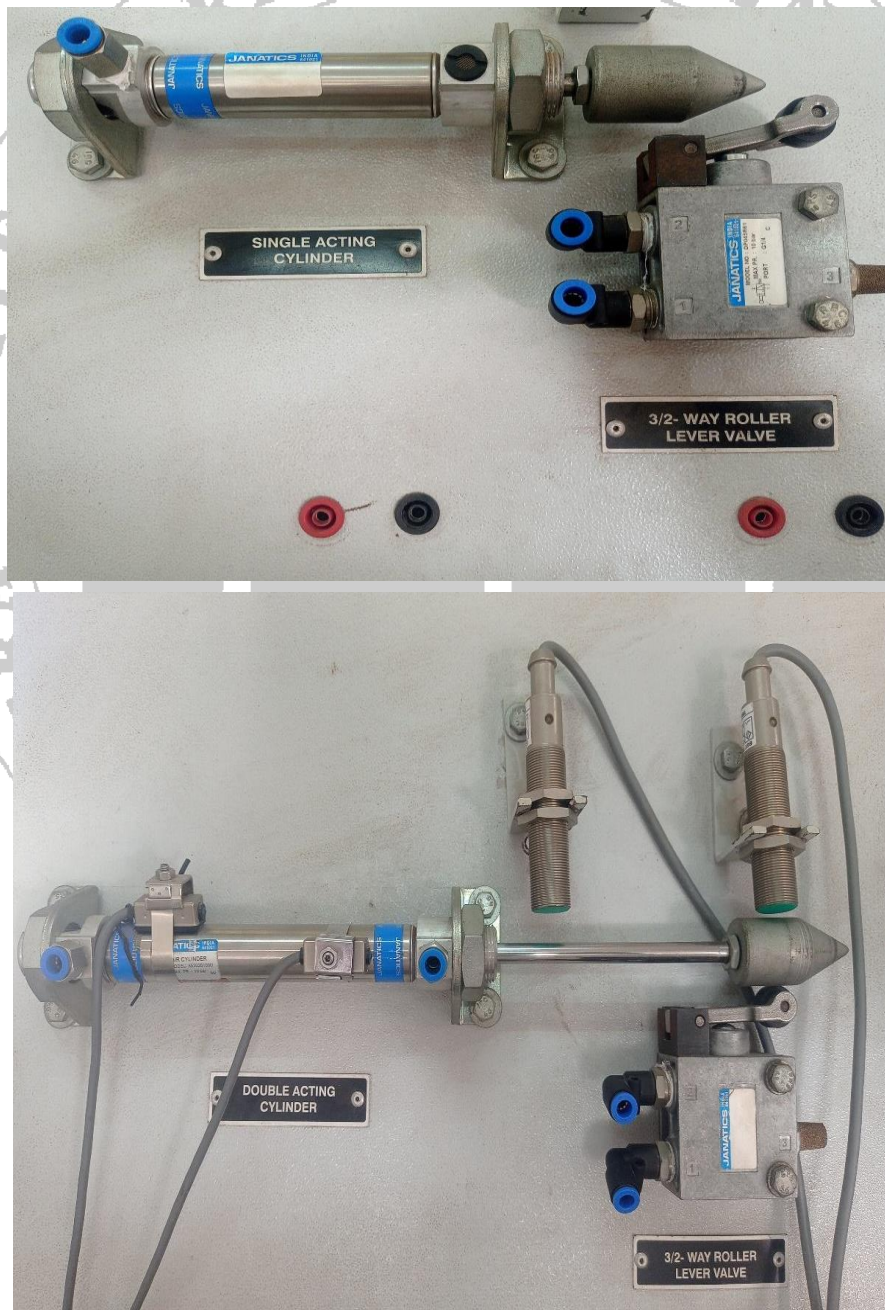

**Fig 10.1 Experimental setup for Lift / Elevator controller using PLC**

**VIII Required Resources/apparatus/equipment with specifications**

| Sr. No. | Name of Resource                            | Suggested Broad Specification  | Quantity |
|---------|---|--|----------|
| 1       | Computer/ Laptop                            | PC preloaded with PLC software and I/O communication facility  | 01       |
| 2       | Programmable Logic Controller (PLC) Trainer | <b>Digital Inputs:-</b> 12 Nos with toggle switches for applying 24V dc inputs.<br><b>Digital Outputs:-</b> 12 Nos with 24V operated Lamp.<br>Analog Inputs: - 02<br>Analog Outputs: - 02<br>External Power Supply: 24 V DC.<br>Memory:-16 K data memory +351K Code Memory +96K upload Memory. | 01       |
| 3       | Electro-Pneumatic Kit                       | Single-acting and double-acting cylinders Kit<br>Solenoid valves (12V/24V DC).<br>Air compressor, relay modules, and power supply units  | 01       |

**IX Precautions to be followed**

1. Follow safety and operational guidelines while using the Laboratory.
2. Ensure proper handling of electronic components to prevent damage from static electricity.
3. Avoid direct contact with high temperatures; use tools or protective equipment as needed.
4. Follow manufacturer guidelines for wiring and installation of PLC and sensors.

**X Procedure**

1. Study the operation of single and double-acting pneumatic actuators
2. Open PLC software.
3. Create a new project and develop a ladder diagram for a Single/Double-acting cylinder. Define input conditions (e.g., push button, proximity sensor). Include output controls (solenoid valves for cylinders).
4. Test and correct the error (If any).
5. Download the program on the PLC.
6. Connect the Module to the PLC and make the required input-output connections.
7. Test the program by selecting the floor.
8. repeat 3 to 6 steps for the different condition.

## Ladder Diagram

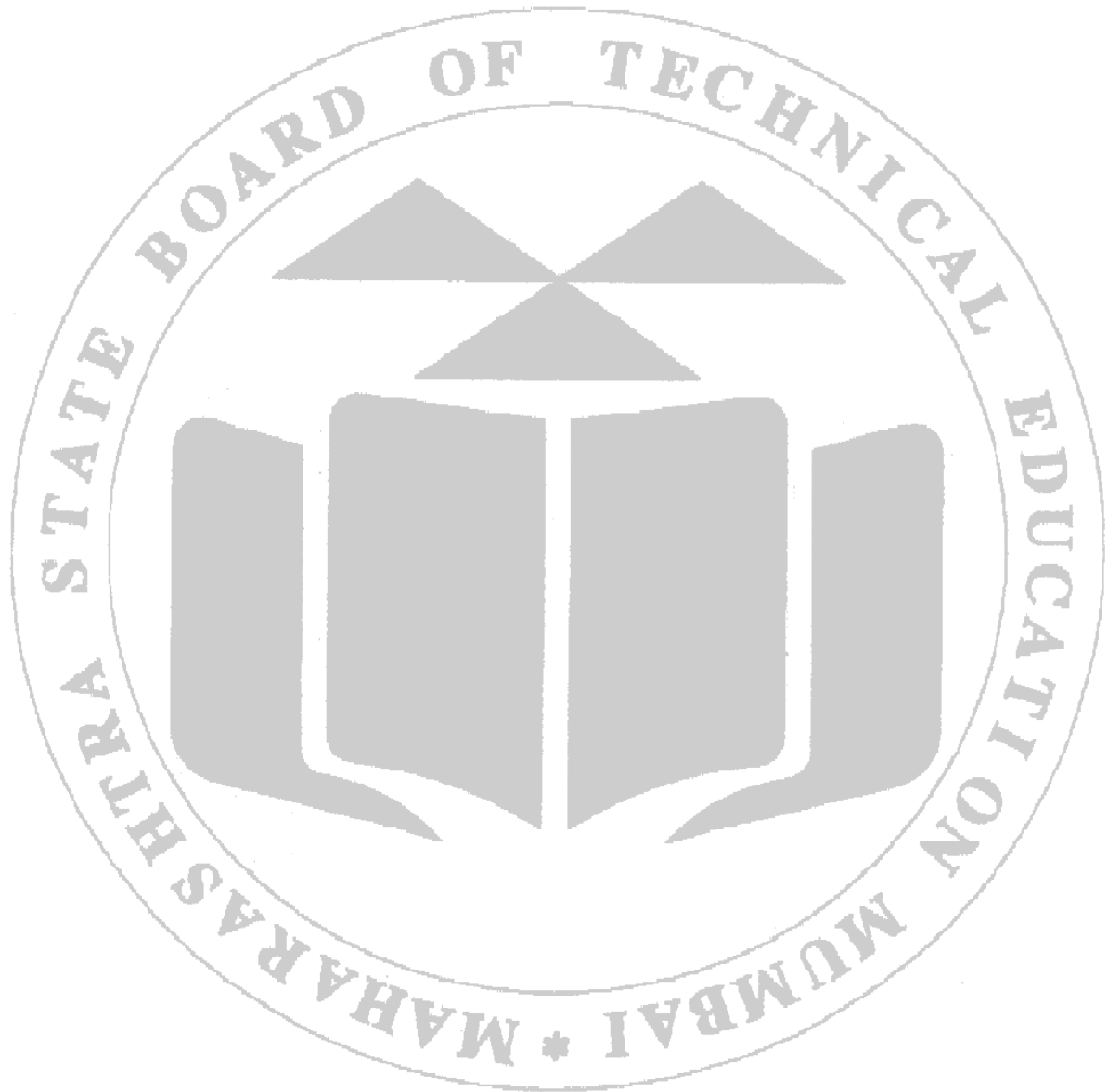

**XI Observation Table**

**Table 11.1 Measurement**

| Sr. No. | Input Condition | Cylinder Type | Output Response | Observation Notes |
|---------|-----------------|---------------|-----------------|-------------------|
| 1       | Push Button 1   | Single-Acting | Extend/Retract  |                   |
| 2       | Push Button 2   | Single-Acting | Extend/Retract  |                   |
| 3       | Push Button 3   | Double-Acting | Extend/Retract  |                   |
| 4       | Push Button 4   | Double-Acting | Extend/Retract  |                   |

**XII Result**

-----  
 -----  
 -----  
 -----  
 -----  
 -----

**XIII Interpretation of results**

-----  
 -----  
 -----  
 -----  
 -----  
 -----

**XIV Conclusion and recommendation**

-----  
 -----  
 -----  
 -----  
 -----  
 -----

**XV Practical related questions**

*Note: Below are a few sample questions for reference. Teachers must design more such questions so as to ensure the achievement of the identified CO.*

1. What is the role of a solenoid valve in the pneumatic system?
2. How does the ladder diagram represent logic operations?



-----

-----

-----

-----

-----

-----

-----

-----

**XVI References/Suggestions for further reading**

1. <https://instrumentationtools.com/elevator-plc-ladder-logic/>
2. <https://swiftlifts.com/hi/how-does-an-elevator-work/>
3. Programmable Logic Controllers by Frank D Petruzella.
4. Mechatronics by W. Bolton.

**XVII Rubrics for Assessment Scheme**

| Performance Indicators            |                                       | Weightage    |
|-----------------------------------|---------------------------------------|--------------|
| <b>Process Related (15 Marks)</b> |                                       | <b>(60%)</b> |
| 1.                                | Handling of the measuring Instruments | 30%          |
| 2.                                | Calculation of final readings         | 30%          |
| <b>Product Related (10 Marks)</b> |                                       | <b>(40%)</b> |
| 3.                                | Interpretation of result              | 20%          |
| 4.                                | Conclusions                           | 10%          |
| 5.                                | Practical related questions           | 10%          |
| <b>Total ( 25 Marks)</b>          |                                       | <b>100 %</b> |

| Marks Obtained       |                      |            | Dated signature of Teacher |
|----------------------|----------------------|------------|----------------------------|
| Process Related (15) | Product Related (10) | Total (25) |                            |
|                      |                      |            |                            |

**Practical No. 12:**  
**Development of Ladder diagram and program PLC for single acting/double acting hydraulic system**

**I Practical Significance**

This experiment helps students understand the application of PLC in controlling hydraulic systems, commonly used in automation industries, robotics, and machine tools.

**II Industry / Employer Expected Outcome(s)**

1. Ability to design and implement ladder logic for pneumatic control systems.
2. Competence in configuring PLCs to control single/double-acting Hydraulic actuators.
3. Understanding of pneumatic system operations in real-world industrial automation scenarios.

**III Course Level Learning Outcome(s)**

- CO1. Identify basic elements of mechatronics system such as sensors, actuators, controllers etc.  
 CO2. Use sensors for different mechatronics systems.  
 CO3. Use actuators for different mechatronics systems.  
 CO4. Develop PLC program for various mechatronics systems.

**IV Laboratory Learning Outcome(s)**

- LLO 12.1: Develop ladder diagram for single-acting/double-acting hydraulic system.  
 LLO 12.2: Execute PLC program for single-acting/double-acting hydraulic system.

**V Relevant Affective Domain-related Outcomes**

1. Follow precautionary measures.
2. Working collaboratively on complex automation projects.
3. Observing safety guidelines and protocols when designing control systems

**VI Relevant Theoretical Background**

**Overview of Hydraulic Systems:**

Hydraulic systems use pressurized fluid to perform mechanical work. They consist of various components, including cylinders (actuators), valves, pumps, and hydraulic fluid. These systems are widely used in industries for automation, robotics, and machine tools due to their ability to handle large loads with precision and control.

**Single-Acting Hydraulic Cylinder:**

A single-acting hydraulic cylinder only operates in one direction, with the return stroke powered by gravity or a spring. It typically has a single port for the hydraulic fluid to enter, and the return stroke occurs without fluid pressure. These cylinders are common in applications where the load is only moved in one direction, such as lifting or pushing actions.

**Applications:**

Used in applications like presses, jacks, and lifting platforms where the load only needs to be raised or extended.

**Double-Acting Hydraulic Cylinder:**

A double-acting cylinder, in contrast, uses hydraulic fluid to move the piston in both directions. There are two ports for hydraulic fluid—one for pushing the piston forward and the other for retracting it. The advantage of a double-acting cylinder is that it allows for a controlled return stroke, offering more precise and flexible movement.

Applications:

Used in machines that need bidirectional movement such as cranes, excavators, and industrial automation systems.

### VII Experimental Setup

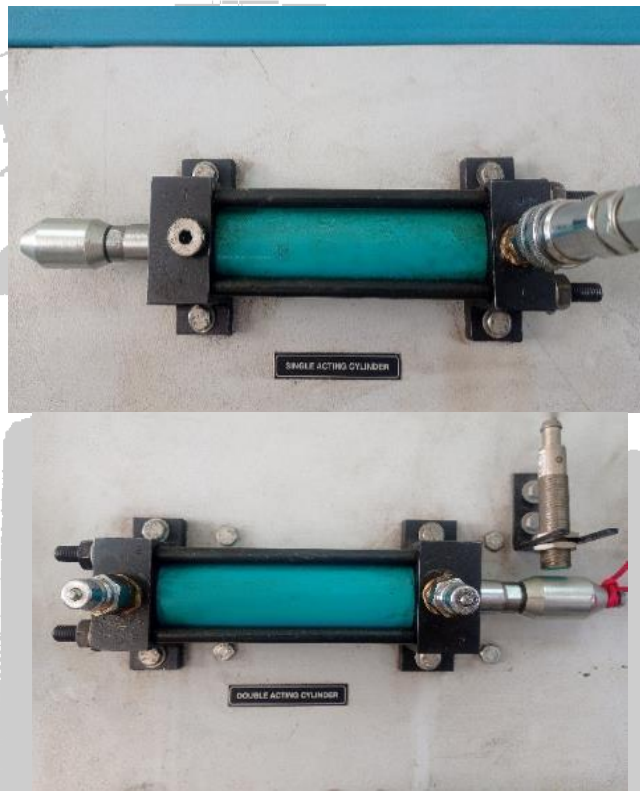

**Fig 12.1 Experimental setup**

**VIII Required Resources/apparatus/equipment with specifications**

| Sr. No. | Name of Resource                            | Suggested Broad Specification  | Quantity |
|---------|---|--|----------|
| 1       | Computer/ Laptop                            | PC preloaded with PLC software and I/O communication facility  | 01       |
| 2       | Programmable Logic Controller (PLC) Trainer | <b>Digital Inputs:-</b> 12 Nos with toggle switches for applying 24V dc inputs.<br><b>Digital Outputs:-</b> 12 Nos with 24V operated Lamp.<br>Analog Inputs: - 02<br>Analog Outputs: - 02<br>External Power Supply: 24 V DC.<br>Memory:-16 K data memory +351K Code Memory +96K upload Memory. | 01       |
| 3       | Electro-Hydraulic Kit                       | Single-acting and double-acting cylinders Kit<br>Solenoid valves (12V/24V DC).   | 01       |

**IX Precautions to be followed**

1. Follow safety and operational guidelines while using the Laboratory.
2. Ensure proper handling of electronic components to prevent damage from static electricity.
3. Avoid direct contact with high temperatures; use tools or protective equipment as needed.
4. Follow manufacturer guidelines for wiring and installation of PLC and sensors.

**X Procedure**

1. Study the operation of single and double-acting pneumatic actuators
2. Open PLC software.
3. Create a new project and develop a ladder diagram for a Single/Double-acting cylinder. Define input conditions (e.g., push button, proximity sensor). Include output controls (solenoid valves for cylinders).
4. Test and correct the error (If any).
5. Download the program on the PLC.
6. Connect the Module to the PLC and make the required input-output connections.
7. Test the program by selecting the floor.
8. repeat 3 to 6 steps for the different condition.

## Ladder Diagram

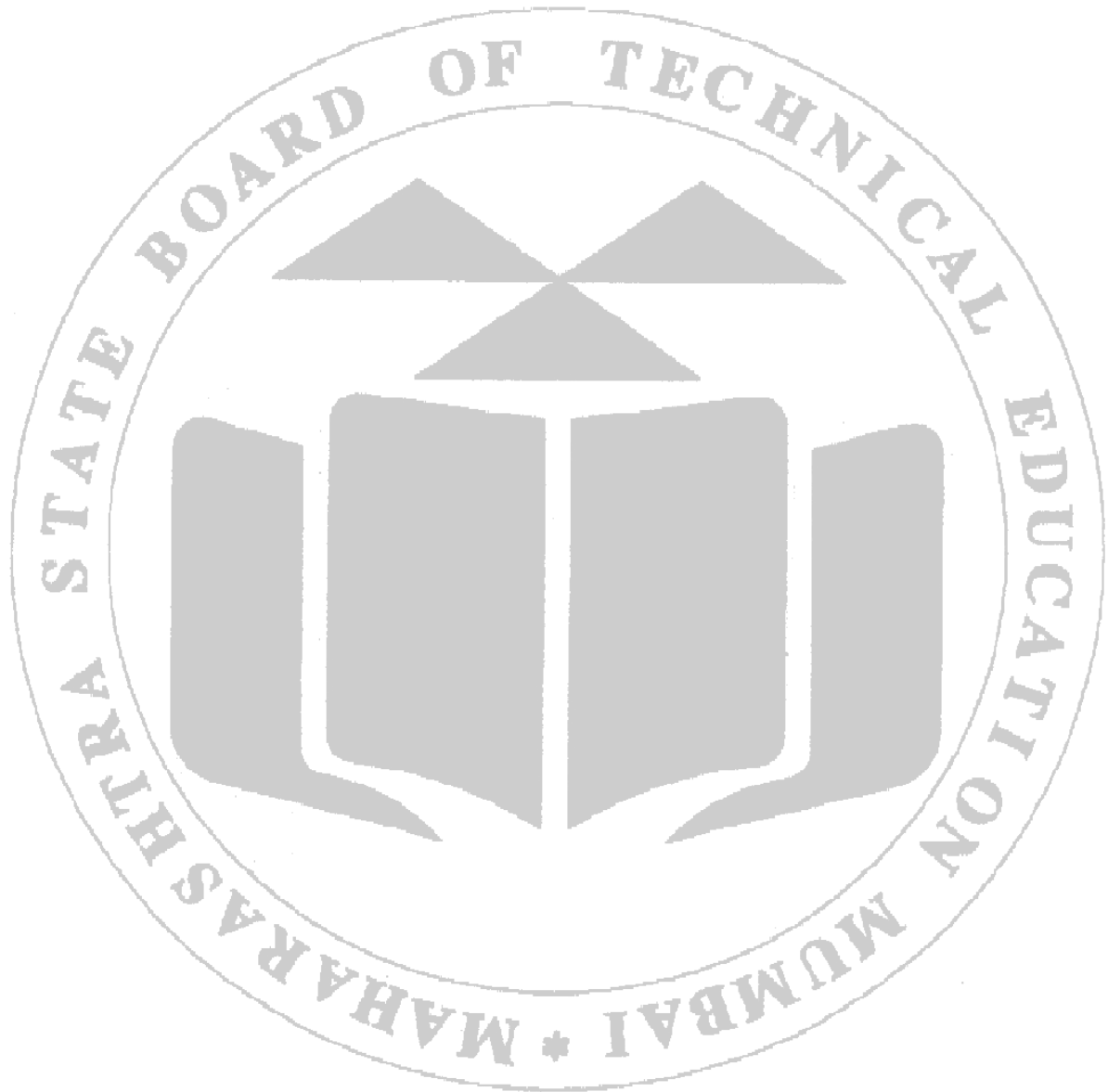

**XI Observation Table**

**Table 11.1 Measurement**

| Sr. No. | Cylinder Type | Input Signal (ON/OFF) | Output Action | Cycle Time |
|---------|---------------|-----------------------|---------------|------------|
| 1       | Single-Acting |                       |               |            |
| 2       | Single-Acting |                       |               |            |
| 3       | Double-Acting |                       |               |            |
| 4       | Double-Acting |                       |               |            |

**XII Result**

.....

.....

.....

.....

.....

.....

.....

.....

.....

**XIII Interpretation of results**

.....

.....

.....

.....

.....

.....

.....

.....

.....

**XIV Conclusion and recommendation**

.....

.....

.....

.....

.....

.....

.....

.....

.....

.....

**XV Practical related questions**

*Note: Below are a few sample questions for reference. Teachers must design more such questions so as to ensure the achievement of the identified CO.*

1. What are the key differences between single-acting and double-acting hydraulic systems?
2. How can you ensure safety during PLC programming and execution?
3. What modifications can be made to the ladder diagram for energy-efficient operation?

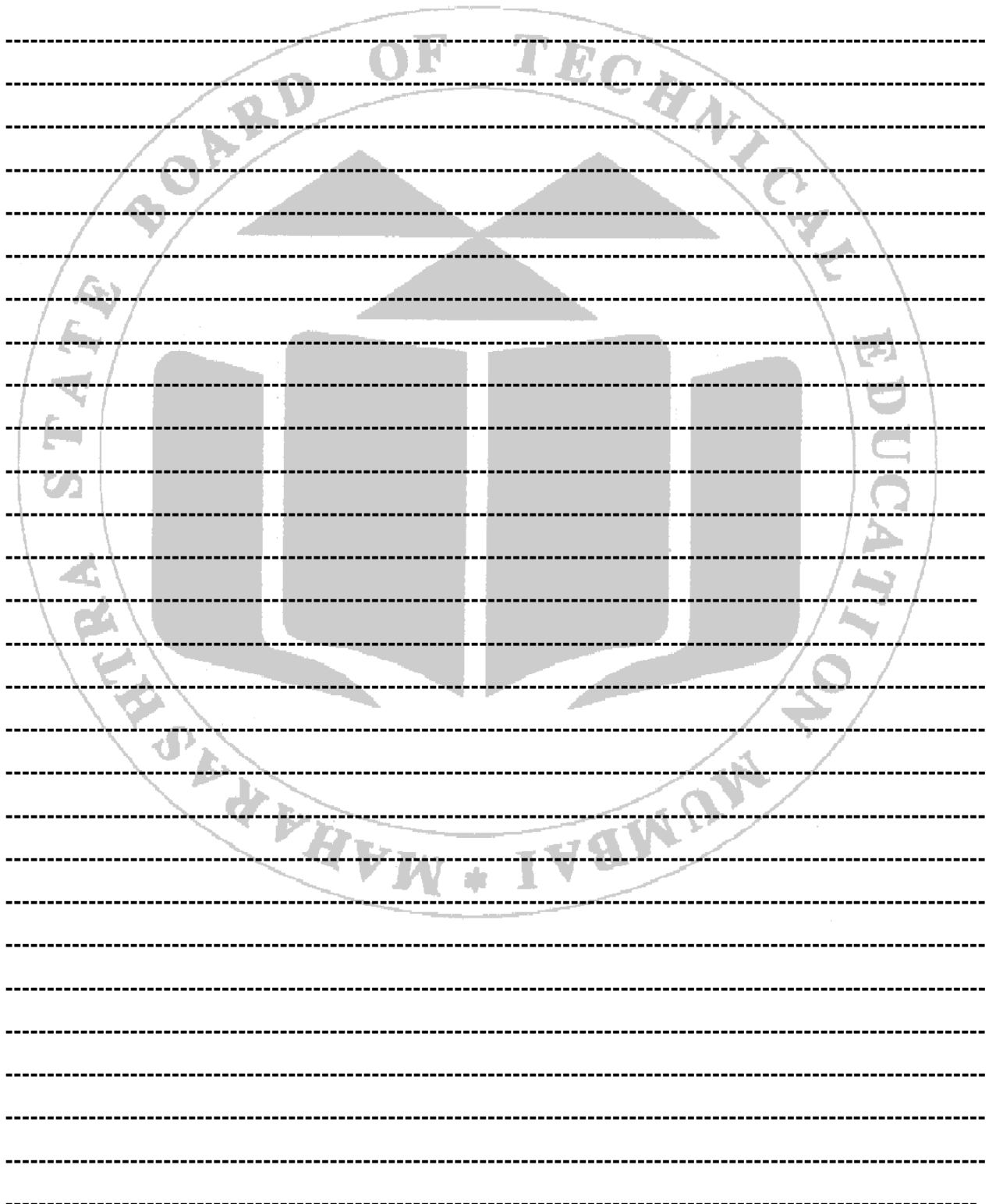



## Practical No. 13

### Development of Ladder diagram and program PLC for door open and close application

#### I Practical Significance

Understanding the application of Programmable Logic Controllers (PLCs) is crucial for automating real-world processes. The door open and close system is a common mechatronic application used in industries such as manufacturing, warehouses, and automation systems.

#### II Industry / Employer Expected Outcome(s)

1. Understanding the design of automated lift control systems.
2. Proficiency in writing and executing PLC programs for industrial applications.
3. Familiarity with safety protocols and operational logic required for elevator systems.

#### III Course Level Learning Outcome(s)

- CO1. Identify basic elements of mechatronics system such as sensors, actuators, controllers etc.  
 CO2. Use sensors for different mechatronics systems.  
 CO3. Use actuators for different mechatronics systems.  
 CO4. Develop PLC program for various mechatronics systems.

#### IV Laboratory Learning Outcome(s)

- LLO 13.1 Develop ladder diagram for door open and close system  
 LLO 13.2 Execute PLC program for door open and close system

#### V Relevant Affective Domain-related Outcomes

1. Follow precautionary measures.
2. Working collaboratively on complex automation projects.
3. Observing safety guidelines and protocols when designing control systems

#### VI Relevant Theoretical Background

**Door Control System:** Consists of sensors and actuators that automate the opening and closing of doors. The sensors detect the presence of an object, and actuators (such as motors) perform the door movement.

#### System Components:

**Sensors:** Sensors like limit switches and proximity sensors detect the position of the door (fully open, fully closed). These sensors provide input signals to the PLC to control the door movement safely and accurately.

- **Limit Switches:** These are typically installed at the door's fully open and fully closed positions. When the door reaches these points, the switches trigger, signalling the PLC to stop the motor.
- **Proximity Sensors:** Optional sensors that detect if an object is in the door's path, which can help prevent accidental closure on a person or object.

**Actuators:** Actuators such as electric motors or pneumatic cylinders are responsible

for moving the door. The PLC sends output signals to these actuators, determining the direction (open or close) based on the ladder diagram logic.

- **Motor Selection:** Commonly, a DC or stepper motor is used for door systems in mechatronics applications. Motor speed and torque are critical factors that the PLC controls based on real-time input from sensors.
- **Door Open and Close System Logic**
- **Control Requirements:** The door should open or close only upon receiving a command (via buttons or sensors). It should stop moving when it reaches the open or close limit switch to prevent damage or safety hazards.
- **Sequential Operation:**
  - Step 1: When the "Open" button is pressed, the PLC activates the motor to open the door until the open limit switch is engaged.
  - Step 2: When the "Close" button is pressed, the PLC activates the motor to close the door until the close limit switch is engaged.
- **Safety Control:** Additional interlocks can prevent the door from moving if an obstacle is detected by proximity sensors, improving safety.

**VII Experimental Setup**

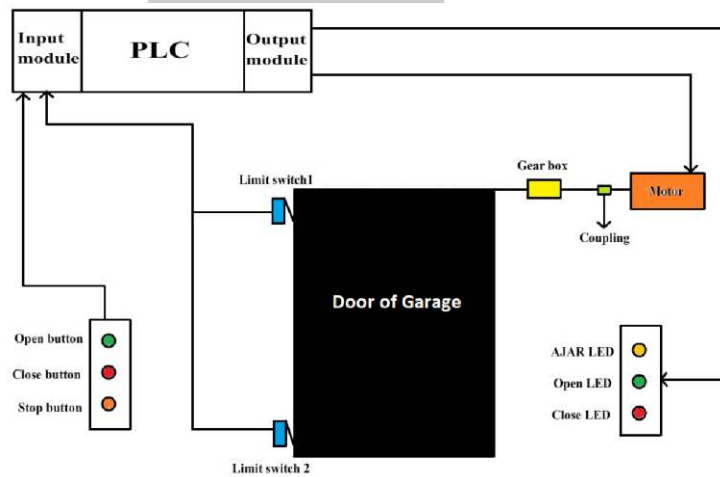

**Fig 13.1 Experimental setup for Door Open/ Close using PLC**

**VIII Required Resources/apparatus/equipment with specifications**

| Sr. No. | Name of Resource                    | Suggested Broad Specification  | Quantity |
|---------|-------------------------------------|--|----------|
| 1       | Computer/ Laptop Programmable Logic | PC preloaded with PLC software and I/O communication facility  | 01       |
| 2       | Controller (PLC) Trainer            | <b>Digital Inputs:-12</b> Nos with toggle switches for applying 24V dc inputs.<br><b>Digital Outputs:-12</b> Nos with 24V operated Lamp.<br><b>Analog Inputs: - 02</b><br><b>Analog Outputs: - 02</b><br><b>External Power Supply: 24 V DC.</b><br><b>Memory:-16 K</b> data memory + <b>351K</b> Code Memory + <b>96K</b> upload Memory. | 01       |

| Sr. No. | Name of Resource    | Suggested Broad Specification  | Quantity |
|---------|---------------------|--|----------|
| 3       | Door Open and Close | Door Open and Close of sensing the arrival and departure of person within a particular distance from door. | 01       |

### IX Precautions to be followed

1. Follow safety and operational guidelines while using the Laboratory.
2. Ensure proper handling of electronic components to prevent damage from static electricity.
3. Avoid direct contact with high temperatures; use tools or protective equipment as needed.
4. Follow manufacturer guidelines for wiring and installation of PLC and sensors.

### X Procedure

1. Open PLC software.
2. Create a new project and develop a ladder diagram for the door open-close function.
3. Test and correct the error (If any).
4. Download the program on the PLC.
5. Connect the open-close Module to the PLC and make the required input-output connections.
6. Test the program by selecting the floor.
7. repeat 3 to 6 steps for the floor and condition.

### Ladder Diagram

**XI Observation Table**

**Table 10.1 Measurement of Temperature.**

| Sr. No. | Distance of person from door | Status of door (open/closed) |
|---------|------------------------------|------------------------------|
| 1       |                              |                              |
| 2       |                              |                              |
| 3       |                              |                              |
| 4       |                              |                              |

**XII Result**

-----

-----

-----

-----

-----

-----

-----

-----

**XIII Interpretation of results**

-----

-----

-----

-----

-----

-----

-----

-----

**XIV Conclusion and recommendation**

-----

-----

-----

-----



**XVI References/Suggestions for further reading**

1. <https://www.automation.com>
2. <https://www.plcademy.com>
3. <https://www.tutorialspoint.com/plc/index.htm>
4. <https://instrumentationtools.com>
5. Programmable Logic Controllers by Frank D Petruzella.
6. Mechatronics by W. Bolton.

**XVII Rubrics for Assessment Scheme**

| Performance Indicators            |                                       | Weightage    |
|-----------------------------------|---------------------------------------|--------------|
| <b>Process Related (15 Marks)</b> |                                       | <b>(60%)</b> |
| 1.                                | Handling of the measuring Instruments | 30%          |
| 2.                                | Calculation of final readings         | 30%          |
| <b>Product Related (10 Marks)</b> |                                       | <b>(40%)</b> |
| 3.                                | Interpretation of result              | 20%          |
| 4.                                | Conclusions                           | 10%          |
| 5.                                | Practical related questions           | 10%          |
| <b>Total ( 25 Marks)</b>          |                                       | <b>100 %</b> |

| Marks Obtained          |                         |            | Dated signature of Teacher |
|-------------------------|-------------------------|------------|----------------------------|
| Process Related<br>(15) | Product Related<br>(10) | Total (25) |                            |
|                         |                         |            |                            |

## Practical No. 14

### Development of Ladder diagram and program PLC for material rejection system

#### I Practical Significance

The practical on developing a ladder diagram and programming a PLC for a material rejection system is crucial for students to understand the basics of automation used in manufacturing industries. By working on this practical, students will gain hands-on experience in creating automated solutions that ensure quality control by rejecting defective or unapproved materials from production lines.

#### II Industry / Employer Expected Outcome(s)

1. Understanding the design of automated lift control systems.
2. Proficiency in writing and executing PLC programs for industrial applications.
3. Familiarity with safety protocols and operational logic required for elevator systems.

#### III Course Level Learning Outcome(s)

- CO1. Identify basic elements of mechatronics system such as sensors, actuators, controllers etc.
- CO2. Use sensors for different mechatronics systems.
- CO3. Use actuators for different mechatronics systems.
- CO4. Develop PLC program for various mechatronics systems.

#### IV Laboratory Learning Outcome(s)

- LLO 14.1: Develop a ladder diagram for the material rejection system.
- LLO 14.2: Execute the PLC program for the material rejection system

#### V Relevant Affective Domain-related Outcomes

1. Follow precautionary measures.
2. Working collaboratively on complex automation projects.
3. Observing safety guidelines and protocols when designing control systems

#### VI Relevant Theoretical Background

**Concept of PLCs:** A Programmable Logic Controller (PLC) is an industrial computer that automates manufacturing processes, such as controlling machinery or factory assembly lines.

**Material Rejection System:** Using sensors and actuators, a system designed to detect and remove defective materials from a conveyor line. The setup may involve a sensor for detection and an actuator, such as a pneumatic arm, for rejection. A Material Rejection System is a common automation setup used in manufacturing to ensure only defect-free products proceed along a production line. If a defective item is detected, the system rejects it using an actuator (e.g., a pneumatic cylinder) to remove the item from the conveyor. This ensures product quality and reduces manual inspection efforts.

**Components Used:**

- **Sensors:** Devices used to detect defective materials. Examples include:  
 Proximity Sensors: Detect the presence or absence of an object without direct contact. Useful for identifying items on a conveyor.  
 Photoelectric Sensors: Emit light beams to detect objects. Commonly used for precise detection in quality control.
- **Actuators:** Mechanisms that perform actions based on signals from the PLC. Examples include:  
 Pneumatic Cylinders: Use compressed air to generate linear motion for rejecting materials.  
 Solenoid Valves: Control the flow of air to actuators.
- **Conveyor System:** A mechanized system to transport materials along a production line.

**VII Experimental Setup**

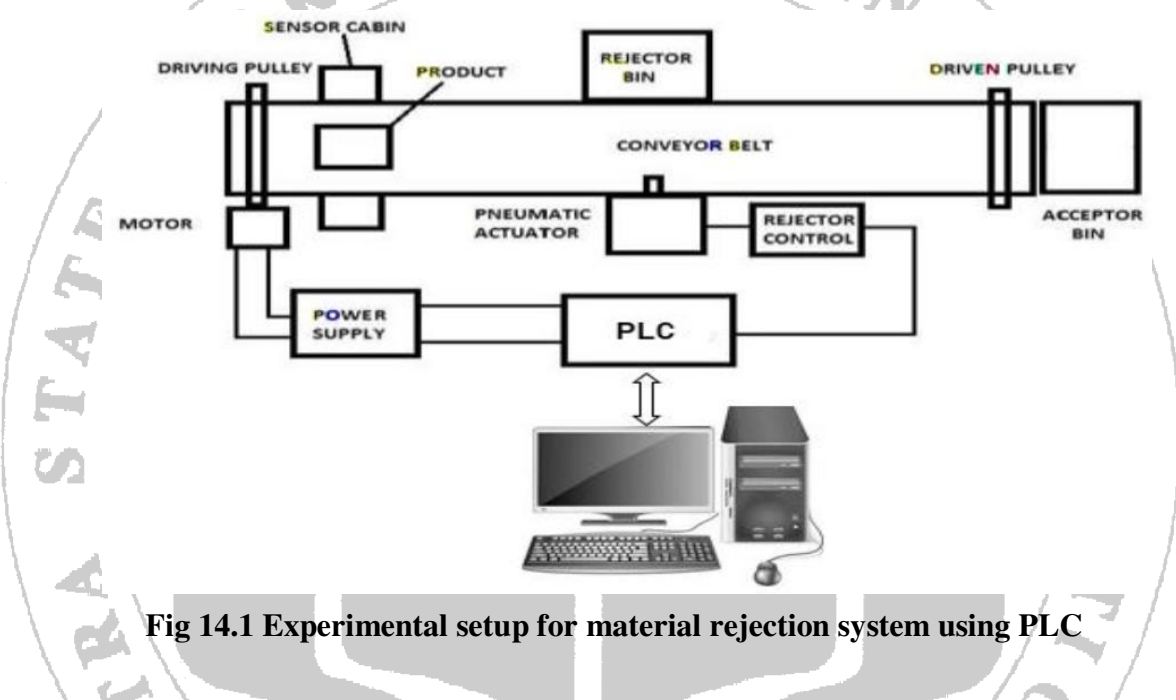

**Fig 14.1 Experimental setup for material rejection system using PLC**

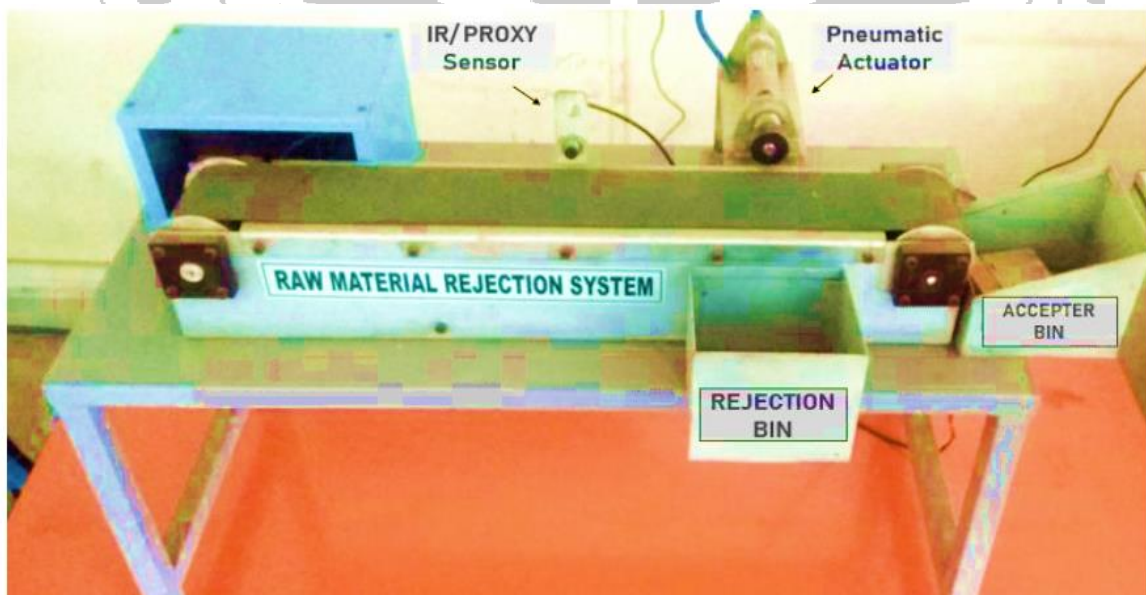

**Fig 14.1 Experimental setup for material rejection system using PLC**

**VIII Required Resources/apparatus/equipment with specifications**

| Sr. No. | Name of Resource                    | Suggested Broad Specification  | Quantity |
|---------|-------------------------------------|--|----------|
| 1       | Computer/ Laptop Programmable Logic | PC preloaded with PLC software and I/O communication facility  | 01       |
| 2       | Controller (PLC) Trainer            | Digital Inputs:-12 Nos with toggle switches for applying 24V dc inputs.<br>Digital Outputs:-12 Nos with 24V operated Lamp.<br>Analog Inputs: - 02<br>Analog Outputs: - 02<br>External Power Supply: 24 V DC.<br>Memory:-16 K data memory +351K Code Memory +96K upload Memory.   | 01       |
| 3       | Raw Material Rejection Module       | Raw Material Rejection Module with a facility to detect, sort and reject the objects. The module should contain a sensor (IR or Proxy) and a Pneumatic actuator controlled by PLC.<br><b>Pneumatic actuator:</b> <ul style="list-style-type: none"> <li>• Type: Single/Double acting pneumatic cylinder.</li> <li>• Bore Size: 8 mm</li> <li>• Stroke: 15 mm.</li> <li>• Operating Temperature = 10-40°C.</li> <li>• Working Medium = Compressed air upto 4 bar pressure.</li> </ul> | 01       |

**IX Precautions to be followed**

1. Follow safety and operational guidelines while using the Laboratory.
2. Ensure proper handling of electronic components to prevent damage from static electricity.
3. Avoid direct contact with high temperatures; use tools or protective equipment as needed.
4. Follow manufacturer guidelines for wiring and installation of PLC and sensors.

**X Procedure**

1. Open PLC software.
2. Create a new project and develop a ladder diagram for the material rejection system.
3. Test and correct the error (If any).
4. Download the program on the PLC.
5. Connect the material rejection system to the PLC and make the required input-output connections.
6. Test the program by selecting the floor.

7. Repeat 3 to 6 steps for the floor and condition.

**Ladder Diagram**

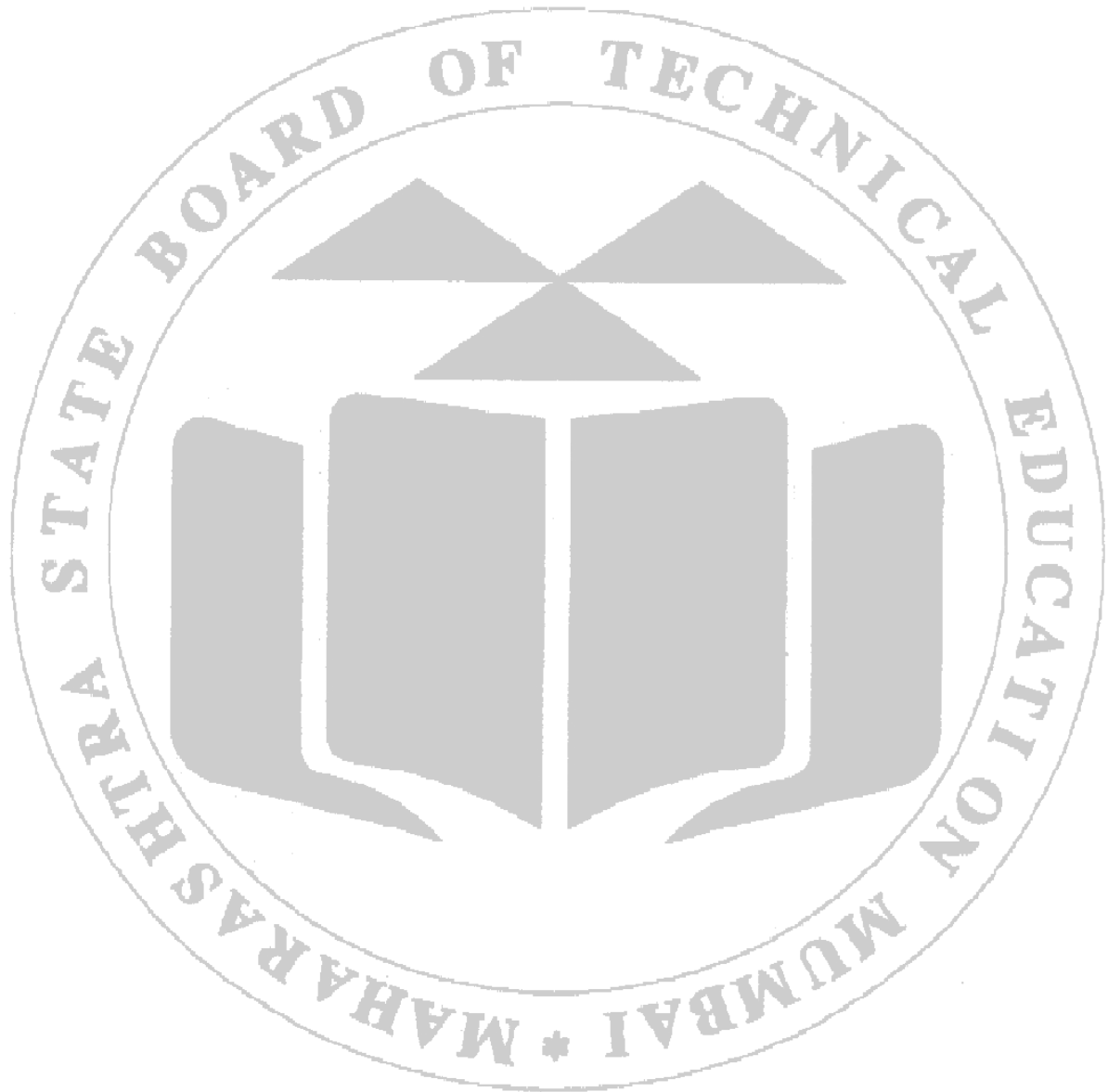

**XI Observation Table**

**Table 10.1 Measurement of Temperature.**

| Object Number | Type of Object |              | Action Taken |          |
|---------------|----------------|--------------|--------------|----------|
|               | Metallic       | Non-Metallic | Accepted     | Rejected |
| 1             |                |              |              |          |
| 2             |                |              |              |          |
| 3             |                |              |              |          |
| 4             |                |              |              |          |
| 5             |                |              |              |          |

**XII Result**

-----

-----

-----

-----

-----

-----

-----

-----

**XIII Interpretation of results**

-----

-----

-----

-----

-----

-----

-----

**XIV Conclusion and recommendation**

-----

-----

-----

-----



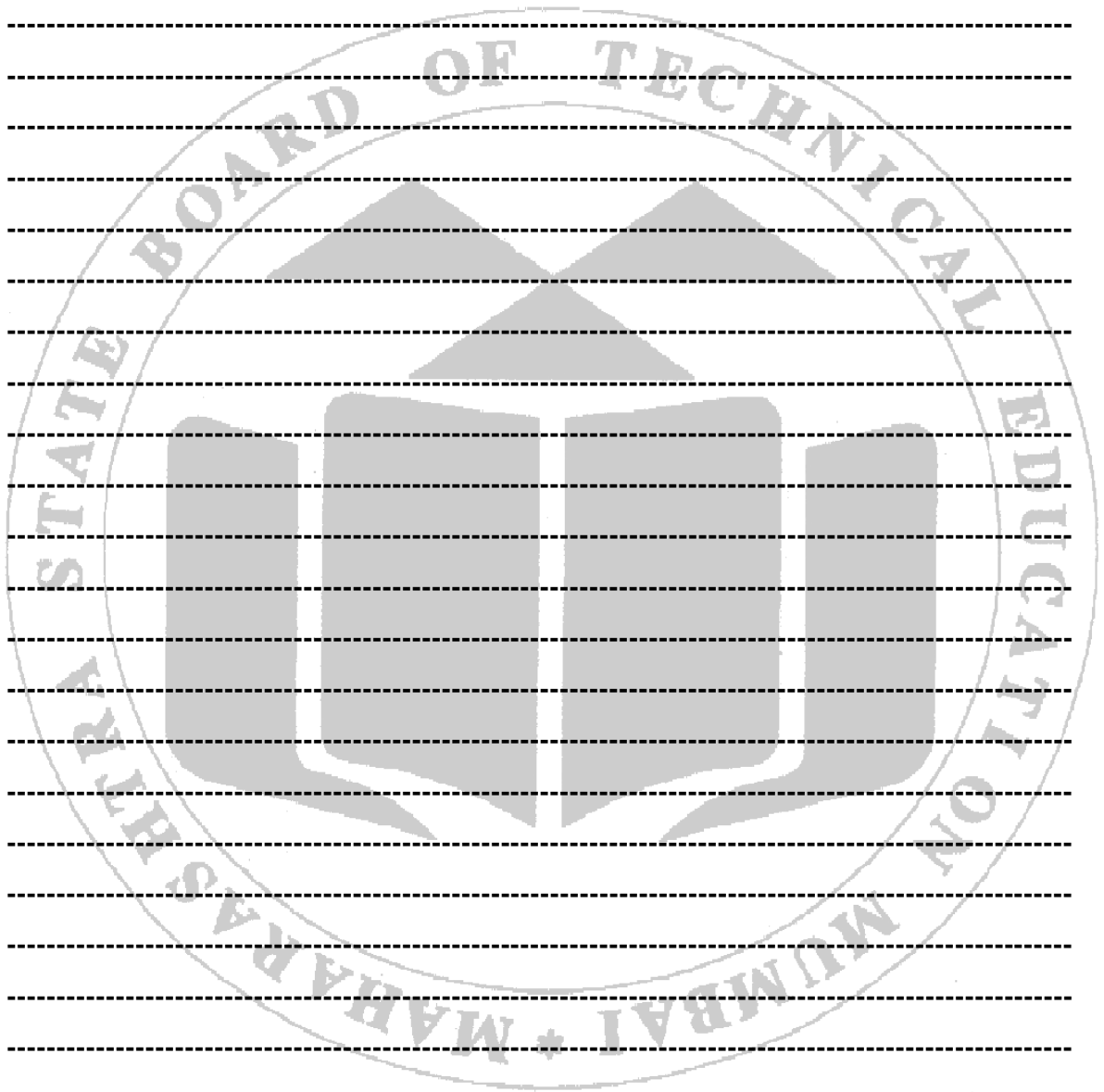

**XVI References/Suggestions for further reading**

1. <https://www.automation.com>
2. <https://www.plcademy.com>
3. <https://instrumentationtools.com>
4. Programmable Logic Controllers by Frank D Petruzella.
5. Mechatronics by W. Bolton.

**XVII Rubrics for Assessment Scheme**

| Performance Indicators            |                                       | Weightage    |
|-----------------------------------|---------------------------------------|--------------|
| <b>Process Related (15 Marks)</b> |                                       | <b>(60%)</b> |
| 1                                 | Handling of the measuring Instruments | 30%          |
| 2                                 | Calculation of final readings         | 30%          |
| <b>Product Related (10 Marks)</b> |                                       | <b>(40%)</b> |
| 3                                 | Interpretation of result              | 20%          |
| 4                                 | Conclusions                           | 10%          |
| 5                                 | Practical related questions           | 10%          |
| <b>Total ( 25 Marks)</b>          |                                       | <b>100 %</b> |

| Marks Obtained       |                      |            | Dated signature of Teacher |
|----------------------|----------------------|------------|----------------------------|
| Process Related (15) | Product Related (10) | Total (25) |                            |
|                      |                      |            |                            |

## Practical No. 15

### Development of 8051 microcontroller program for stepper motor control

#### I Practical Significance

Understanding how to control a stepper motor using an 8051 microcontroller is fundamental in applications involving precise positioning and speed control, such as robotics, CNC machines, and automated systems. It bridges theoretical knowledge with hands-on programming and practical implementation.

#### II Industry / Employer Expected Outcome(s)

1. Ability to develop and execute microcontroller programs for motor control.
2. Skill in integrating microcontroller systems into mechatronic applications, ensuring efficient and accurate operation.
3. Familiarity with industry standards in motor control applications.

#### III Course Level Learning Outcome(s)

- CO1. Identify basic elements of mechatronics system such as sensors, actuators, controllers etc.
- CO2. Use sensors for different mechatronics systems.
- CO5. Use microcontroller for different mechatronics systems.

#### IV Laboratory Learning Outcome(s)

- LLO 15.1: Develop an 8051 microcontroller program for stepper motor control.
- LLO 15.2: Execute the 8051 microcontroller program for stepper motor operation.

#### V Relevant Affective Domain-related Outcomes

1. Follow precautionary measures.
2. Working collaboratively on complex automation projects.
3. Observing safety guidelines and protocols when designing control systems

#### VI Relevant Theoretical Background

A stepper motor is a brushless DC motor, which can be rotated in small angles, the angles are called steps. Generally, stepper motors use 200 steps to complete 360-degree rotation, meaning they rotate 1.8 degrees per step. Stepper motors are used in many devices which need precise rotational movement like robots, antennas, hard drives etc. We can rotate the stepper motor to any particular angle by giving it proper instructions. A Stepper motor comes in two types: Unipolar and Bipolar. A unipolar stepper motor generally has five or six wires, in which four wires are one end of four stator coils, and the other end of the four coils is tied together making the fifth wire, this is called common wire. Bipolar stepper motor there is just four wires coming out from two sets of coils, meaning there are no common wires.

The working of this circuit is very simple. A method called Half-Stepping is implemented in the program to rotate the Stepper Motor. When the forward button is pushed, the stepper motor rotates in a clockwise direction.

Similarly, when the backward button is pushed, it starts rotating in an anti-clockwise direction.

To stop the rotation completely, you can press the stop button

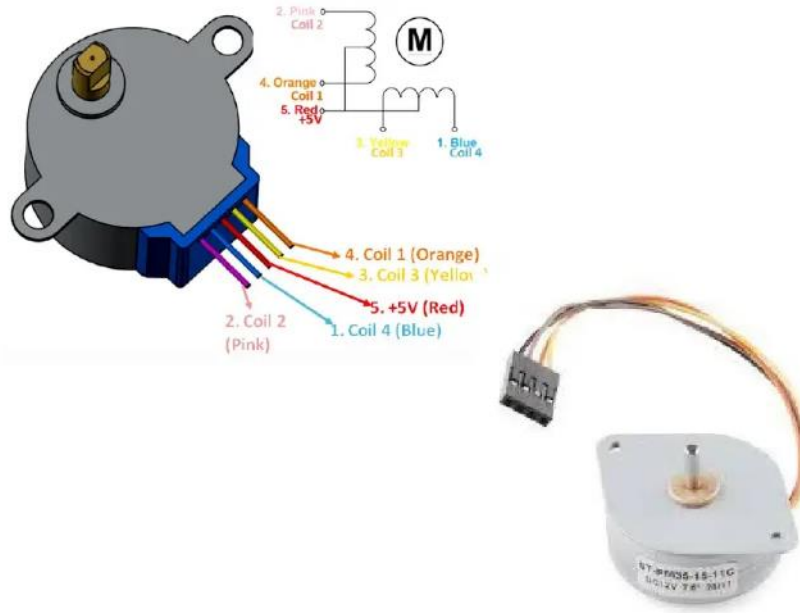

**Applications:**

- Robotics: Precise movement control
- 3D Printers: Layer-by-layer material deposition
- Automation Systems: Conveyor belt position control

**VII Experimental Setup**

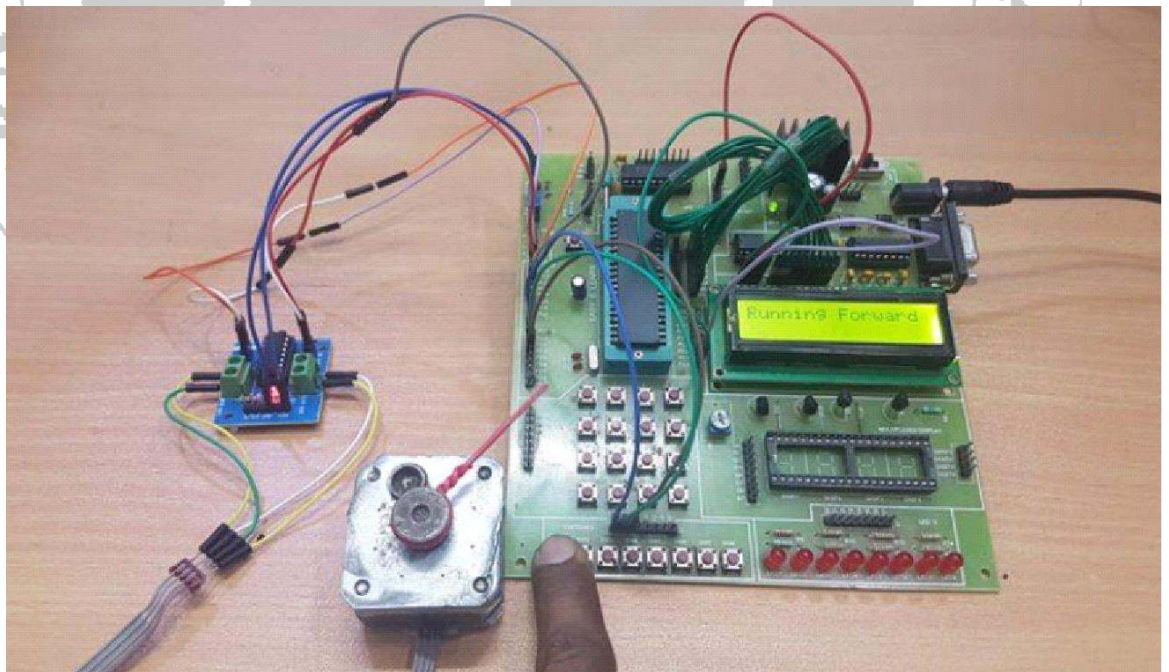

**Fig 15.1 Experimental Setup for 8051 Microcontroller Program for Stepper Motor Control**

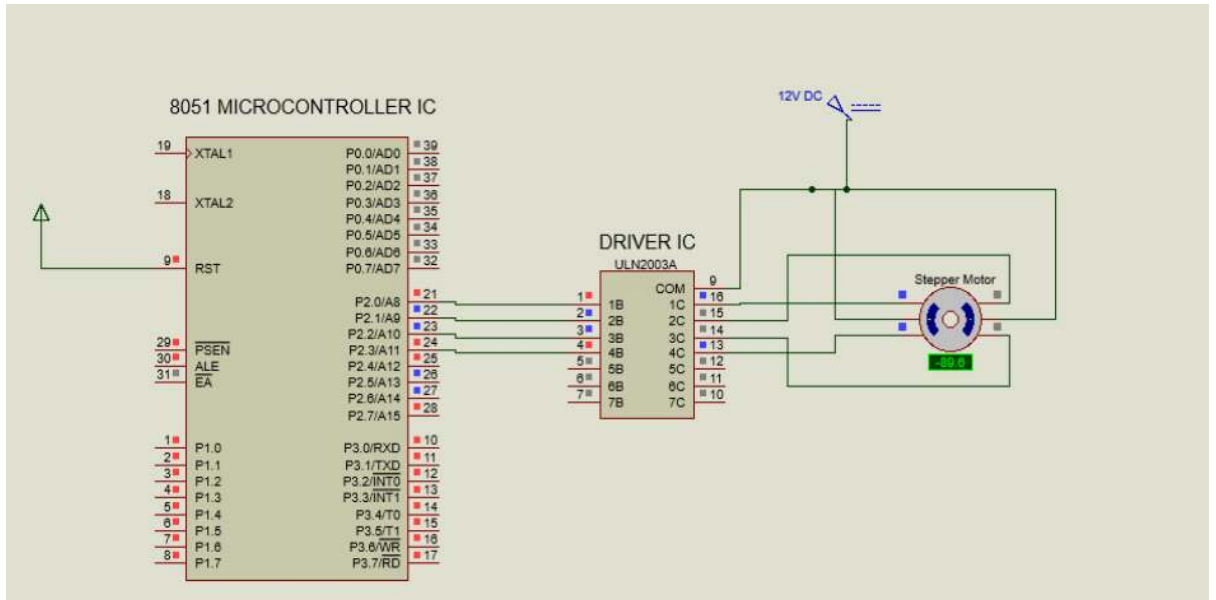

**Fig 15.2 Experimental Setup for 8051 Microcontroller Program for Stepper Motor Control**

**VIII Required Resources/apparatus/equipment with specifications**

| Sr. No. | Name of Resource                    | Suggested Broad Specification   | Quantity |
|---------|-------------------------------------|---|----------|
| 1       | Computer/ Laptop Programmable Logic | PC preloaded with software to develop and download the program in microcontroller memory.                             | 01       |
| 2       | Microcontroller Development Board   | 8051 development board with +5v supply, facility for IO port expansion, and inbuilt (or add-on) stepper motor module. | 01       |

**IX Precautions to be followed**

1. Follow safety and operational guidelines while using the Laboratory.
2. Ensure proper handling of electronic components to prevent damage from static electricity.
3. Avoid improper connections of stepper motor with microcontroller.
4. Follow manufacturer guidelines.

**X Procedure**

1. Open the programming software.
2. Create new project.
3. Develop the assembly language program for stepper motor.
4. Test and debug the program for errors (if any).
5. Connect the 8051 board to PC using a serial (RS232 or USB) cable.

6. Download the .hex file in 8051 microcontroller using program burning software.
7. Interface stepper motor module with the appropriate port of 8051 microcontroller.
8. Execute the program and observe the rotation of the stepper motor.
9. Repeat steps 3 to step 8 for different speeds of the motor by varying the delay..

**Space for 8051 Program:**

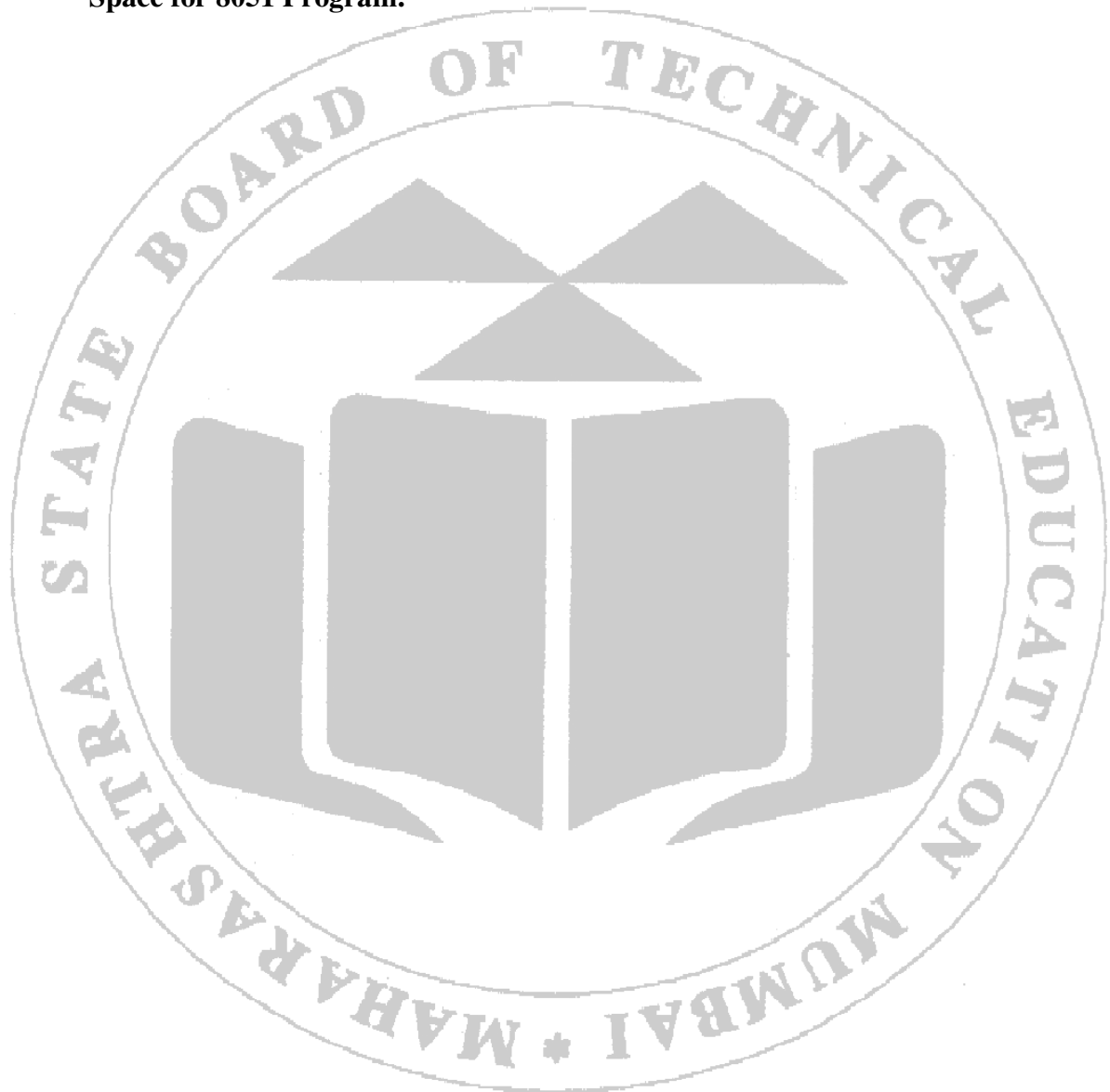

**XI Observation Table**

**Table 10.1 Measurement of Temperature.**

**Table 1: Full Step (4-step sequence)**

| Step No. | Winding of stepper motor |   |   |   |
|----------|--------------------------|---|---|---|
|          | A                        | B | C | D |
| 1        |                          |   |   |   |
| 2        |                          |   |   |   |
| 3        |                          |   |   |   |
| 4        |                          |   |   |   |

**Table 2: Half Step (8-step sequence)**

| Step No. | winding of stepper motor |   |   |   |
|----------|--------------------------|---|---|---|
|          | A                        | B | C | D |
| 1        |                          |   |   |   |
| 2        |                          |   |   |   |
| 3        |                          |   |   |   |
| 4        |                          |   |   |   |
| 5        |                          |   |   |   |
| 6        |                          |   |   |   |
| 7        |                          |   |   |   |
| 8        |                          |   |   |   |

**XII Result**

-----

-----

-----

-----

-----

-----

-----

**XIII Interpretation of results**

-----

-----

-----

-----

-----



-----

-----

-----

-----

-----

-----

-----

-----

-----

-----

**XVI References/Suggestions for further reading**

1. <https://www.engineersgarage.com/microcontroller-projects/>
2. <https://www.plcademy.com>
3. <https://instrumentationtools.com>
4. Programmable Logic Controllers by Frank D Petruzella.
5. Mechatronics by W. Bolton.

**XVII Rubrics for Assessment Scheme**

| Performance Indicators            |                                       | Weightage    |
|-----------------------------------|---------------------------------------|--------------|
| <b>Process Related (15 Marks)</b> |                                       | <b>(60%)</b> |
| 1.                                | Handling of the measuring Instruments | 30%          |
| 2.                                | Calculation of final readings         | 30%          |
| <b>Product Related (10 Marks)</b> |                                       | <b>(40%)</b> |
| 3.                                | Interpretation of result              | 20%          |
| 4.                                | Conclusions                           | 10%          |
| 5.                                | Practical related questions           | 10%          |
| <b>Total ( 25 Marks)</b>          |                                       | <b>100 %</b> |

| Marks Obtained       |                      |            | Dated signature of Teacher |
|----------------------|----------------------|------------|----------------------------|
| Process Related (15) | Product Related (10) | Total (25) |                            |
|                      |                      |            |                            |

## Practical No. 16

### Development of 8051 microcontroller program for relay interfacing

#### I Practical Significance

Understanding the interfacing of a relay with an 8051 microcontroller is essential for controlling high-power devices like motors, lights, or industrial machines through a microcontroller in real-world applications..

#### II Industry / Employer Expected Outcome(s)

1. Ability to develop and execute microcontroller programs for motor control.
2. Skill in integrating microcontroller systems into mechatronic applications, ensuring efficient and accurate operation.
3. Familiarity with industry standards in motor control applications.

#### III Course Level Learning Outcome(s)

- CO1. Identify basic elements of mechatronics system such as sensors, actuators, controllers etc.  
 CO2. Use sensors for different mechatronics systems.  
 CO5. Use microcontroller for different mechatronics systems.

#### IV Laboratory Learning Outcome(s)

- LLO 16.1: Develop 8051 microcontroller program for relay interfacing.  
 LLO 16.2: Execute 8051 microcontroller program for relay interfacing.

#### V Relevant Affective Domain-related Outcomes

1. Follow precautionary measures.
2. Working collaboratively on complex automation projects.
3. Observing safety guidelines and protocols when designing control systems

#### VI Relevant Theoretical Background

**Relay Basics:** A relay is an electromechanical switch that uses a small control signal to operate a larger electrical load.

**8051 Microcontroller:** Features such as I/O ports, timers, and interrupt handling make it suitable for interfacing tasks.

**Interfacing Principle:** The 8051 microcontroller uses its output pins to control a transistor, which drives the relay coil. A flyback diode is used to prevent voltage spikes.

#### Applications:

- Robotics: Precise movement control
- 3D Printers: Layer-by-layer material deposition
- Automation Systems: Conveyor belt position control

**VII Experimental Setup**

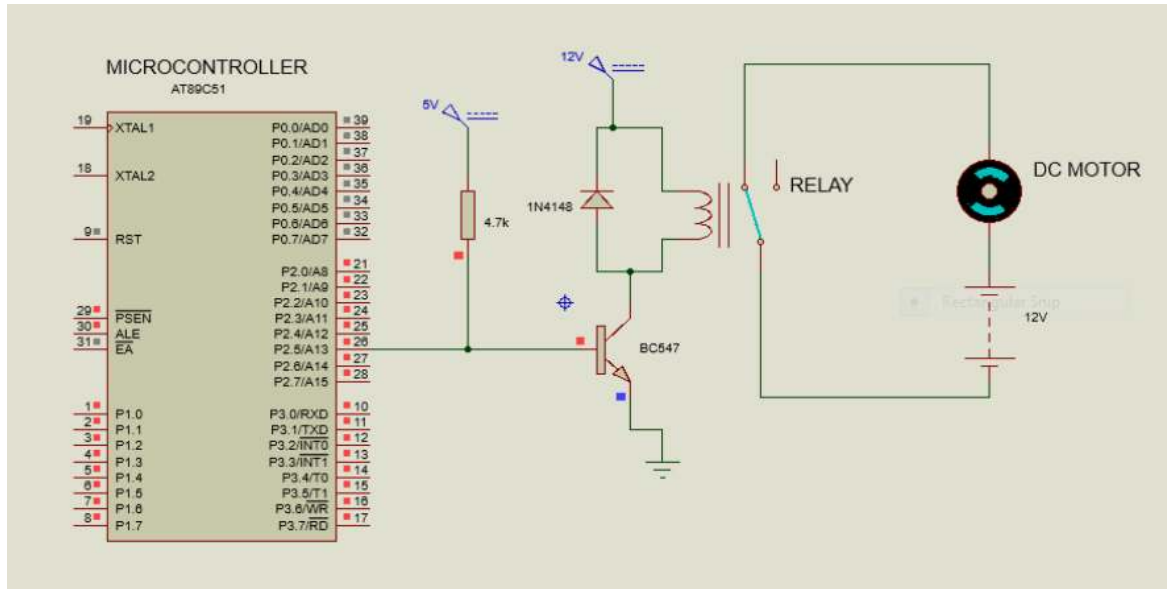

**Fig 16.1 Experimental Setup for 8051 Microcontroller Program for relay interfacing**

**VIII Required Resources/apparatus/equipment with specifications**

| Sr. No. | Name of Resource                    | Suggested Broad Specification   | Quantity             |
|---------|-------------------------------------|---|----------------------|
| 1       | Computer/ Laptop Programmable Logic | PC preloaded with software to develop and download the program in microcontroller memory.                             | 01                   |
| 2       | Microcontroller Development Board   | 8051 development board with +5v supply, facility for IO port expansion, and inbuilt (or add-on) stepper motor module. | 01                   |
| 3       | Relay interfacing circuit           | Relay: 12V/5V<br>Transistor: BC547<br>Resistors:4.7K<br>Freewheeling Diode: 1N4148/1N4007                             | 01<br>01<br>01<br>01 |

**IX Precautions to be followed**

1. Follow safety and operational guidelines while using the Laboratory.
2. Ensure proper handling of electronic components to prevent damage from static electricity.
3. Avoid improper connections of the stepper motor with microcontroller.
4. Follow manufacturer guidelines.

## X Procedure

1. Open the programming software.
2. Create new project.
3. Develop the program in assembly language for relay interfacing
4. Test and debug the program for errors (if any).
5. Connect the 8051 board to the PC using a serial cable (RS232 or USB).
6. Download the .hex file in the code memory of the 8051 microcontroller using program-burning software.
7. Interface relay circuitry with the appropriate port of the 8051 microcontroller
8. Connect the motor/lamp to the relay and switch on the power supply.
9. Execute the program and observe the switching on/off the motor/lamp.
10. Repeat the above steps by exchanging connections between the NO and NC pins of the relay.

**Space for 8051 Program:**

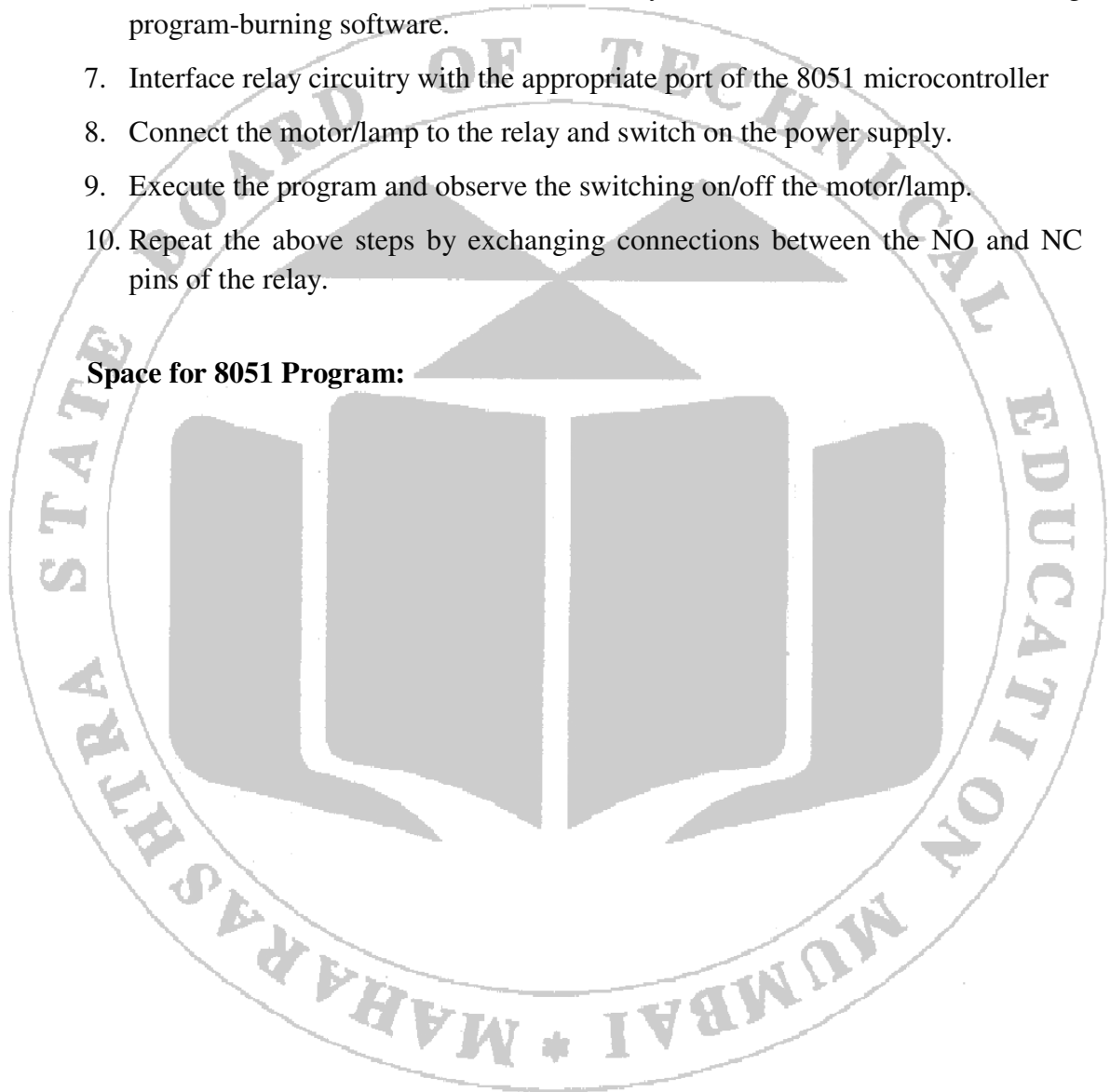

**XI Observation Table**

**Table 16.1 Measurement of Temperature.**

| The logic level on a port pin                                   | Motor status (ON/OFF) |
|---|-----------------------|
| <b>When NO terminal of the relay is used for connection</b>     |                       |
| LOW   |                       |
| HIGH  |                       |
| <b>When the NC terminal of the relay is used for connection</b> |                       |
| LOW   |                       |
| HIGH  |                       |

**XII Result**

-----

-----

-----

-----

-----

-----

-----

-----

-----

-----

**XIII Interpretation of results**

-----

-----

-----

-----

-----

-----

-----

-----

**XIV Conclusion and recommendation**

-----

-----

-----

-----

-----

-----

-----

-----



-----

-----

-----

-----

-----

-----

**XVI References/Suggestions for further reading**

1. <https://www.engineersgarage.com/microcontroller-projects/>
2. <https://www.plcademy.com>
3. <https://instrumentationtools.com>
4. The 8051 Microcontroller and Embedded System using Assembly and C  
Muhammad Ali Mazidi
5. The 8051 Microcontroller by Kenneth Ayala
6. [www.engineersgarage.com](http://www.engineersgarage.com)

**XVII Rubrics for Assessment Scheme**

| Performance Indicators            |                                       | Weightage    |
|-----------------------------------|---------------------------------------|--------------|
| <b>Process Related (15 Marks)</b> |                                       | <b>(60%)</b> |
| 1.                                | Handling of the measuring Instruments | 30%          |
| 2.                                | Calculation of final readings         | 30%          |
| <b>Product Related (10 Marks)</b> |                                       | <b>(40%)</b> |
| 3.                                | Interpretation of result              | 20%          |
| 4.                                | Conclusions                           | 10%          |
| 5.                                | Practical related questions           | 10%          |
| <b>Total ( 25 Marks)</b>          |                                       | <b>100 %</b> |

| Marks Obtained       |                      |            | Dated signature of Teacher |
|----------------------|----------------------|------------|----------------------------|
| Process Related (15) | Product Related (10) | Total (25) |                            |
|                      |                      |            |                            |