

SCHEME : K

Name : _____
Roll No. : _____ Year : 20__ 20__
Exam Seat No. : _____

LABORATORY MANUAL FOR CONSUMER ELECTRONIC SYSTEMS (314327)

MICROWAVE OVEN

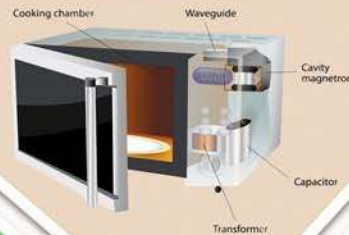

ELECTRONICS ENGINEERING GROUP



**MAHARASHTRA STATE BOARD OF
TECHNICAL EDUCATION, MUMBAI
(Autonomous) (ISO 9001: 2015) (ISO/IEC 27001:2013)**

VISION

To ensure that the Diploma Level Technical Education constantly matches the latest requirements of technology and industry and includes the all-round personal development of students including social concerns and to become globally competitive, technology led organization.

MISSION

To provide high quality technical and managerial manpower, information and consultancy services to the industry and community to enable the industry and community to face the changing technological and environmental challenges.

QUALITY POLICY

We, at MSBTE, are committed to offer the best in class academic services to the students and institutes to enhance the delight of industry and society. This will be achieved through continual improvement in management practices adopted in the process of curriculum design, development, implementation evaluation and monitoring system along with adequate faculty development Programs.

CORE VALUES

MSBTE believes in the followings:

- Education industry produces live products.
- Market requirements do not wait for curriculum changes.
- Question paper is the reflector of academic standards of educational organization
- Well-designed curriculum needs effective implementation too.
- Competency based curriculum is the backbone of need based programs.
- Technical skills do need support for life skills.
- Best teachers are the national assets.
- Effective teaching learning process is impossible without learning resources.

A Laboratory Manual
for
Consumer Electronic Systems
(314327)

Semester-IV
(DE/ EJ/ ET/ EX/ IE/ TE)



Maharashtra State
Board of Technical Education, Mumbai
(Autonomous) (ISO 9001:2015) (ISO/IEC 27001:2013)



**Maharashtra State
Board of Technical Education, Mumbai**
(Autonomous) (ISO 9001:2015) (ISO/IEC 27001:2013)
4th Floor, Polytechnic Building, 49, Kherwadi, Bandra (East),
Mumbai - 400051.



**MAHARASHTRA STATE BOARD
OF TECHNICAL EDUCATION
Certificate**

This is to certify that Mr. / Ms.
Roll No.....of Fourth Semester of Diploma in
..... of Institute
(Code:.....) has attained pre-defined practical outcomes (PROs)
Satisfactorily in course **Consumer Electronic Systems (314327)** for the
Academic year 20..... to 20..... as prescribed in the curriculum.

Place:

Enrollment No:

Date:

Exam. Seat No:

Course Teacher

Head of the Department

Principal



Preface

The primary focus of any engineering laboratory/field work in the technical education system is to develop the much needed industry relevant competencies and skills. With this in view, MSBTE embarked on this innovative ‘K’ Scheme curricula for engineering diploma programs with outcome-based education as the focus and accordingly, a relatively large amount of time is allotted for the practical work. This displays the great importance of laboratory work, making each teacher, instructor and student realize that every minute of the laboratory time needs to be effectively utilized to develop these outcomes, rather than doing other mundane activities. Therefore, for the successful implementation of this outcome-based curriculum, every practical has been designed to serve as a ‘*vehicle*’ to develop this industry identified competency in every student. The practical skills are difficult to develop through ‘chalk and duster’ activity in the classroom situation. Accordingly, the ‘K’ scheme laboratory manual development team designed the practical’s to *focus* on the *outcomes*, rather than the traditional age old practice of conducting practical’s to ‘verify the theory’ (which may become a byproduct along the way).

This laboratory manual is designed to help all stakeholders, especially the students, teachers and instructors to develop in the student the predetermined outcomes. It is expected from each student that at least a day in advance, they have to thoroughly read through the concerned practical procedure that they will do the next day and understand the minimum theoretical background associated with the practical. Every practical in this manual begins by identifying the competency, industry relevant skills, course outcomes and practical outcomes which serve as a key focal point for doing the practical. The students will then become aware about the skills they will achieve through the procedure shown there and necessary precautions to be taken, which will help them to apply in solving real-world problems in their professional life.

This manual also provides guidelines to teachers and instructors to effectively facilitate student- centered lab activities through each practical exercise by arranging and managing necessary resources in order that the students follow the procedures and precautions systematically ensuring the achievement of outcomes in the students.

The usage and demand for consumer electronic appliances is increasing in both domestic as well as industries. This increases the demand for trained man power in the relevant industries. The course Consumer Electronic Systems (314327) will provide working principles of various consumer appliances/gadgets /equipment and skills to troubleshoot and maintain them in a scientific way. The knowledge gained will help the students in the manufacturing units of these consumer gadgets or help the students to start their own enterprise.

Although best possible care has been taken to check for errors (if any) in this laboratory manual, perfection may elude us as this is the first edition of this manual. Any errors and suggestions for improvement are solicited and highly welcome.

Program Outcomes (POs) and Program Specific Outcomes (PSOs) to be achieved through Practical's of this Course

Following program outcomes are expected to be achieved through the practical of the course.

PO1: Basic and Discipline specific knowledge: Apply knowledge of basic mathematics, science and engineering fundamentals and engineering specialization to solve the broad based Electronics & Communication engineering problems.

PO2: Problem analysis: Identify and analyze well-defined Electronics & Communication engineering problems using codified standard methods.

PO3: Design/ development of solutions: Design solutions for well-defined technical problems and assist with the design of Electronics & Communication systems components or processes to meet specified needs.

PO4: Engineering Tools, Experimentation and Testing: Apply modern Electronics & Communication engineering tools and appropriate technique to conduct standard tests and measurements.

PO5: Engineering practices for society, sustainability and environment: Apply appropriate Electronics & Communication technology in context of society, sustainability, environment and ethical practices.

PO6: Project Management: Use Electronics & Communication engineering management principles individually, as a team member or a leader to manage projects and effectively communicate about well- defined engineering activities.

PO7: Life-long learning: Ability to analyze individual needs and engage in updating in the context of Electronics & Communication technological changes.

List of Industry Relevant Skills

The following industry relevant skills of the competency “Use of various electronics consumer equipment’s for relevant consumer applications” are expected to be developed in the student by undertaking the practical of this laboratory manual

1. Identify the components used in audio and video systems.
2. Test microphones and speakers.
3. Maintain various audio systems.
4. Troubleshoot various consumer electronic appliances.
5. Maintain electronic consumer appliances.
6. Troubleshoot office automation appliances.

Practical- Course Outcome matrix

Course Outcomes (COs)						
CO1- Maintain the given type of audio system.						
CO2- Test different types of video systems.						
CO3-Troubleshoot various consumer electronic appliances.						
CO4- Use various smart appliances.						
CO5- Maintain various office automation appliances.						
Sr. No.	Title of the Practical	CO 1	CO 2	CO 3	CO 4	CO 5
1.	Performance of given type of Microphone	✓	-	-	-	-
2.	*Performance of given Speaker	✓	-	-	-	-
3.	*Performance of given Hi-Fi amplifier	✓	-	-	-	-
4.	*Fault identification in Hi-Fi amplifier	✓	-	-	-	-
5.	*Test the CCTV unit	-	✓	-	-	-
6.	Connection of CCTV cameras to DVR/IVR	-	✓	-	-	-
7.	Voltage analysis of power supply section, audio section and video section of LCD TV.	-	✓	-	-	-
8.	Fault analysis of LCD TV.	-	✓	-	-	-
9.	Voltage analysis of given sections of LED TV.	-	✓	-	-	-
10.	*Fault analysis of LED TV.	-	✓	-	-	-
11.	* Dismantling and assembling of paper feed mechanism in photocopier machine	-	-	✓	-	-
12.	*Identification of front panel controls of microwave oven	-	-	✓	-	-
13.	*Fault analysis in microwave oven	-	-	✓	-	-
14.	*Performance of washing machine	-	-	✓	-	-
15.	Sketch the wiring diagram of washing machine	-	-	✓	-	-

Course Outcomes (COs)

CO1- Maintain the given type of audio system.

CO2- Test different types of video systems.

CO3-Troubleshoot various consumer electronic appliances.

CO4- Use various smart appliances.

CO5- Maintain various office automation appliances.

Sr. No.	Title of the Practical	CO	CO	CO	CO	CO
		1	2	3	4	5
16.	Fault analysis of washing machine	-	-	✓	-	-
17.	Use of various functions of CAMCORDER	-	-	✓	-	-
18.	*Interfacing of Scanner	-	-	✓	-	-
19.	Performance of given wearable antenna.	-	-	-	✓	-
20.	*Display faults in smart wrist band	-	-	-	✓	-
21.	Data backup from wearable device	-	-	-	✓	-
22.	Connection problems in VR headset	-	-	-	✓	-
23.	Performance of VR headset	-	-	-	✓	-
24.	*Interfacing of Laser printer	-	-	-	-	✓
25.	* Fault analysis of cartridge related problems of Laser printer	-	-	-	-	✓
26.	*Performance of Laser Printer	-	-	-	-	✓
27.	Interfacing of LED Projector	-	-	-	-	✓
28.	*Creating new interactive white board pages	-	-	-	-	✓
29.	Assess the quality of video conferencing session.	-	-	-	-	✓
30.	Determination of capacity and speed of a shredding machine.	-	-	-	-	✓

Guidelines to Teachers

1. Teacher should provide the guideline with demonstration of practical to the students with all features.
2. Teacher shall explain prior concepts to the students before starting of each practical.
3. Involve students in the performance of each experiment.
4. Teacher should ensure that the respective skills and competencies are developed in the students after the completion of the practical exercise.
5. Teachers should give opportunities to students for hands-on experience after the demonstration.
6. Teacher is expected to share the skills and competencies to be developed in the students.
7. Teacher may provide additional knowledge and skills to the students even though not covered in the manual but are expected of the students by the industry.
8. Finally give practical assignments and assess the performance of students based on tasks assigned to check whether it is as per the instructions.
9. Teacher is expected to refer complete curriculum document and follow guidelines for implementation
10. At the beginning of the practical which is based on the simulation, teacher should make the students acquainted with any simulation software environment.

Instructions for Students

1. Listen carefully to the lecture given by the teacher about course, curriculum, learning structure, skills to be developed.
2. Organize the work in the group and make a record of all observations.
3. Do the calculations and plot the graph wherever it is required in the practical
4. Students shall develop maintenance skills as expected by industries.
5. Student shall attempt to develop related hand-on skills and gain confidence.
6. Student shall develop the habits of evolving more ideas, innovations, skills etc. those included in scope of manual
7. Student should develop the habit to submit the practical on date and time.
8. Student should prepare well while submitting a write-up of exercise.

Content Page

List of Practical's and Progressive Assessment Sheet

Sr. No.	Title of the practical	Page No.	Date of performance	Date of submission	Assessment marks (25)	Dated sign. Of teacher	Remarks (if any)
1.	Performance of given type of microphone	1					
2.	*Performance of given Speaker	8					
3.	*Performance of given Hi-Fi amplifier	16					
4.	*Fault identification in Hi-Fi amplifier	23					
5.	*Test the CCTV unit	30					
6.	Connection of CCTV cameras to DVR/IVR	37					
7.	Voltage analysis of power supply section, audio section and video section of LCD TV.	45					
8.	Fault analysis of LCD TV.	53					
9.	Voltage analysis of given sections of LED TV.	60					
10.	*Fault analysis of LED TV.	66					
11.	* Dismantling and assembling of paper feed mechanism in photocopier machine.	72					
12.	*Identification of front panel controls of microwave oven	79					
13.	*Fault analysis in microwave oven	85					
14.	*Performance of washing machine	92					
15.	Sketch the wiring diagram of washing machine	98					

Sr. No.	Title of the practical	Page No.	Date of performance	Date of submission	Assessment marks (25)	Dated sign. Of teacher	Remarks (if any)
16.	Fault analysis of washing machine	105					
17.	Use of various functions of Camcorder.	113					
18.	*Interfacing of Scanner	120					
19.	Performance of given wearable antenna.	126					
20.	*Display faults in smart wrist band	133					
21.	Data backup from wearable device	140					
22.	Connection problems in VR headset	145					
23.	Performance of VR headset	152					
24.	*Interfacing of Laser printer	159					
25.	* Fault analysis of cartridge related problems of Laser printer	165					
26.	*Performance of Laser Printer	172					
27.	Interfacing of LED Projector	179					
28.	*Creating new interactive white board pages.	187					
29.	Assess the quality of video conferencing session.	194					
30.	Determination of capacity and speed of a shredding machine.	202					
Total							

Note: Out of above suggestive LLOs -

- '*' Marked Practical's (LLOs) are mandatory.
- Minimum 80% of above list of lab experiment are to be performed.
- Judicial mix of LLOs are to be performed to achieve desired outcome

Practical No. 1: Performance of given type of microphone

I Practical Significance:

A Microphone is a transducer which converts sound input obtained from a loudspeaker or from a live program i.e. audio signal into electrical signal.

II Industry / Employer Expected outcome(s)

The aim of this practical is to attend the following industry/employer expected outcome through various teaching learning experiences

Maintain various consumer electronic appliances/equipment.

III Course Level Learning outcome(s)

- Maintain the given type of audio system.

IV Laboratory Learning outcome(s)

- Test and measure the various parameters of a microphone.

V Relevant Affective Domain related outcome(s)

1. Handle components and equipment carefully.
2. Follow safety precautions.

VI Relevant Theoretical Background.

The loud microphone is a transducer which converts sound signal to electrical signal. It is also called an input transducer. The microphone performance based on following characteristics:

1. Sensitivity
2. SNR
3. Frequency Response
4. Distortion
5. Directivity
6. Output Impedance.

There are different types of loudspeakers they are:

1. Capacitive
2. Crystal
- 3 Ribbon
- 4) Hot wire

The type of microphone used in practice is capacitive type. The microphones are also designed on the basis of their frequency response, Sensitivity, SNR, Output impedance, Distortion.

VII Circuit diagram used in a laboratory with related equipment rating.

a. Suggested Kit / Circuit Diagram:



Figure 1.1 Hi-Fi Amplifier Kit

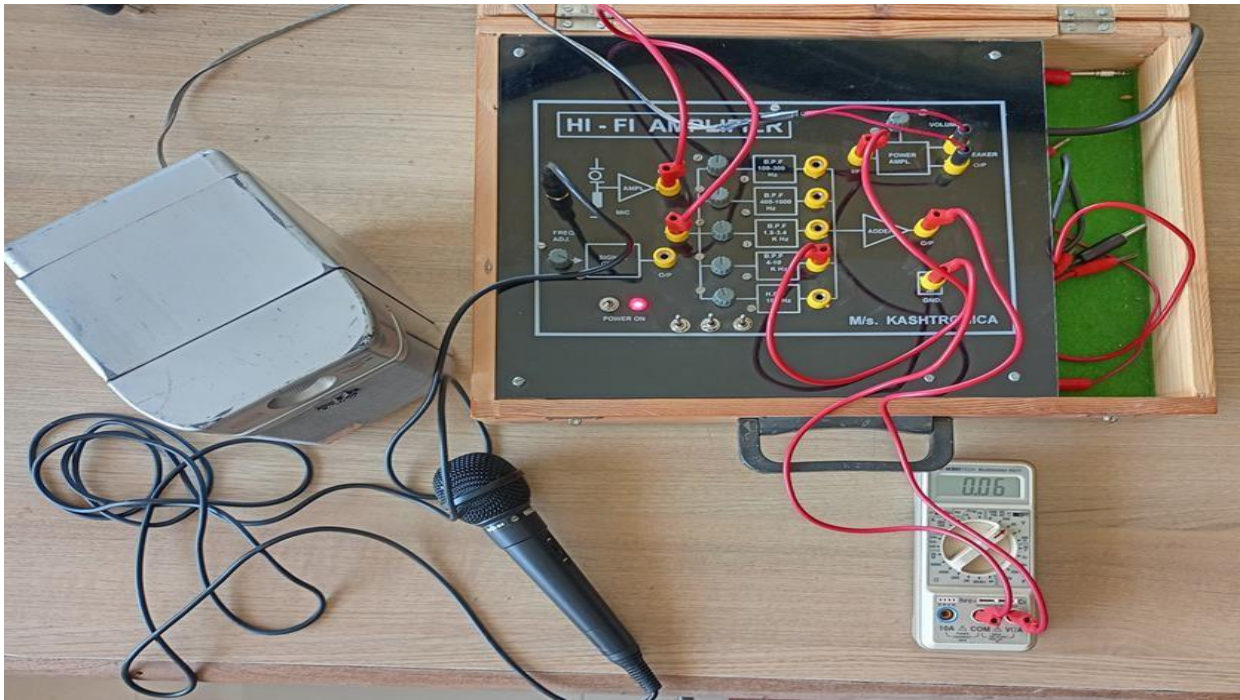

Figure 1.2: Hi-Fi Amplifier Kit with MIC and Speaker connection

b. Actual circuit diagram/Kit used in the laboratory:**VIII Required Resources/apparatus/equipment with specifications:**

Sr. No.	Instruments/Components	Specifications	Quantity
01	Hi-Fi amplifier Kit	Using IC 741 and LM 380	01
02	CRO	20 MHz Dual slope	01
03	Multi-meter	Digital Multi-meter: 3&1/2 digit display.	01
04	Connecting Cords/Wires	As per requirement	-

IX Precautions to be followed (Safety instructions / Rules / Standards)

- 1 Do not switch on the power supply unless you have checked the circuit connection as per circuit diagram.
- 2 Select the proper ranges of CRO and multi-meter.

X Procedure:

- 1 Connect the given microphone to the Input connection of MIC on the kit.
- 2 Connect the given speaker to the output of the power amplifier.
- 3 Connect the output of the microphone and signal generator to the input of the filter & adder circuit.
- 4 Keep pots of all four Band Pass Filter (BPF) and High Pass Filter (HPF) at maximum position.
- 5 Switch on Power Supply.
- 6 Observe output of adder on CRO as well as on speaker you can hear speech or sound or both.
- 7 Keep BPF pot 1 and 2 of ranges 100 to 300 Hz and 400 to 1000 Hz at minimum position and observe output on CRO as well as on speaker you can hear only sound but not speech.
- 8 Keep BPF pot 3 of range 1.5 to 3.4 KHz at minimum position and observe output on CRO as well as on speaker you can hear only speech but not sound.

XI Required Resources

Sr. No.	Instruments/Components	Specifications	Quantity
1			
2			
3			
4			

XII Actual procedure followed

.....

.....

.....

.....

.....

.....

.....

.....

.....

.....

XIII Observation table

Speaker impedance: _____ ohm

Speaker Wattage: _____ W

Sr. No.	Selection of BPF and HPF filter	Position of BPF and HPF filter pot	Amplitude of Waveform on CRO	Observation on speaker
1	All BPF and HPF	Maximum position	_____ Volts	Only Sound/only Speech/both
2	BPF pot 1 and 2 of ranges 100 to 300 Hz and 400 to 1000 Hz	Minimum Position	_____ Volts	Only Sound/only Speech/both
	All other BPF and HPF	Maximum position		
3	BPF pot 3 of range 1.5 to 3.4KHz	Minimum Position	_____ Volts	Only Sound/only Speech/both
	All other BPF and HPF	Maximum position		

XVIII References/Suggestions for further reading: include websites/links/Virtual**Lab Link.**

- 1 Manual of Kashtronica-kit
- 2 <https://www.hackatronic.com/lm380-audio-power-amplifier-circuit-and-its-working>
- 3 <https://www.circuits-diy.com/stereo-amplifier-circuit-using-lm380/>

XIX Assessment Scheme

Performance Indicators		Weightage
Process Related (15 Marks)		60%
01	Identification of different blocks on trainer kit	10%
02	Connection made on kit	20%
03	Observation and Measurement taken	20%
04	Handling of equipment and Working in team	10%
Product Related (10 Marks)		40%
05	Interpretation of Results	15%
06	Conclusions	05%
07	Practical Related Questions	15%
08	Submission of Journal in time	05%
Total (25 Marks)		100%

Marks Obtained			Dated Signature of Teacher
Process Related (15)	Product Related (10)	Total (25)	

Practical No. 02: Performance of given Speaker

I Practical Significance:

A loudspeaker is an electro acoustic transducer which converts electrical input obtained from a microphone (after sufficient amplification) into acoustic (Sound). It is a reverse of the microphone.

II Industry / Employer Expected outcome(s)

The aim of this practical is to attend the following industry/employer expected outcome through various teaching learning experiences.

Maintain various consumer electronic appliances/equipment.

III Course Level Learning outcome(s)

- Maintain the given type of audio system.

IV Laboratory Learning outcome(s)

- Test the given speaker and plot its frequency response.

V Relevant Affective Domain related outcome(s)

- 1 Handle components and equipment carefully.
- 2 Follow safety precautions.

VI Relevant Theoretical Background.

The loud speaker is a transducer which converts electrical signals of audio frequency to sound waves of same frequency. It is also called an output transducer. The loud speaker performance is based on the following characteristics.

1. Efficiency
2. Noise
3. Frequency Response
4. Distortion
5. Directivity
6. Power
7. Impedance

There are different types of loudspeakers they are

1. Electrostatic
2. Dynamic
3. Permanent Magnet.

The type of speakers used in practice is Permanent Magnet type. The speakers are also designed on the basis of their frequency response such as Woofer (Low frequency Audio), mid frequency audio speaker and Tweeter (High frequency audio) Double cone speakers are available which have two diaphragms for giving response for low and high audio frequency.

VII Circuit diagram used in a laboratory with related equipment rating.
a. Suggested Kit / Circuit Diagram:



Figure 2.1:Hi-Fi Amplifier Kit

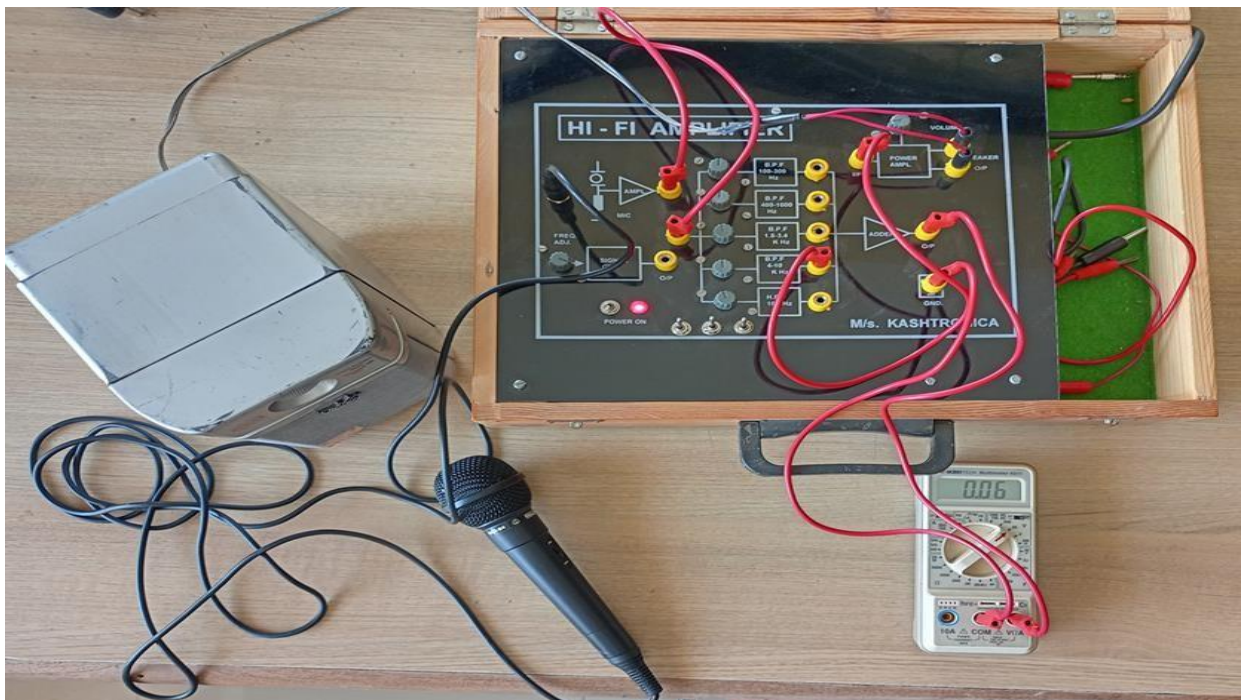

Figure 2.2: Hi-Fi Amplifier Kit with MIC and Speaker connection

b. Actual circuit diagram/Kit used in the laboratory:**VIII Required Resources/apparatus/equipment with specifications:**

Sr. No.	Instruments/Components	Specifications	Quantity
01	Hi-Fi amplifier Kit	Using IC 741 and LM 380	01
02	CRO	20 MHz Dual slope	01
03	Multimeter	Digital Multimeter: 3&1/2 digit display.	01
04	Connecting Cords/Wires	As per requirement	-

IX Precautions to be followed (Safety instructions / Rules / Standards)

1. Do not switch on the power supply unless you have checked the circuit connection as per circuit diagram.
2. Select the proper ranges of CRO and multi-meter.

X Procedure:

1. Connect the given speaker to the output of the power amplifier.
2. Connect signal generator to the input of the filter & adder circuit. Keep the signal generator pot at the minimum position.
3. Keep pots of all four Band Pass Filter (BPF) and High Pass Filter (HPF) at maximum position.
4. Switch on Power Supply.
5. Observe output on CRO and record the reading.
6. Vary frequency of signal generator from minimum to maximum, and take reading at regular intervals and plot graph of frequency versus output.
7. Keep pot of BPF of range 1.5 to 3.4 KHz at minimum position and repeat step 6.
8. Repeat step 5 for different positions of pots of BPF.

XI Required Resources

Sr. No.	Instruments/Components	Specifications	Quantity

XII Actual procedure followed

.....

.....

.....

.....

.....

.....

.....

.....

.....

.....

XIII Observation table:

Input voltage: _____volts.

Input frequency	Output voltage	Input frequency	Output voltage
50 Hz.			
100 Hz.			
200 Hz.			
300 Hz.			
500 Hz.			

XIV Result(s)

.....
.....

XV Interpretation of Results:

Speaker gives output between:

.....
.....

XVI Conclusions and Recommendations:

.....
.....
.....

XVII Practical Related Questions:

Note: Below given are few sample questions. Teachers must design such questions to ensure achievement of identified CO.

1. Which type of speakers are used in movie theaters?
2. List and state function of different types of speakers.
3. Compare different types of loudspeaker.
4. Draw and explain electrodynamic loudspeaker.
5. Draw block diagram of moving coil or cone types of loudspeaker.

[Space for Answers]

.....
.....
.....
.....
.....
.....
.....
.....
.....
.....
.....
.....
.....
.....
.....
.....
.....
.....
.....
.....
.....
.....

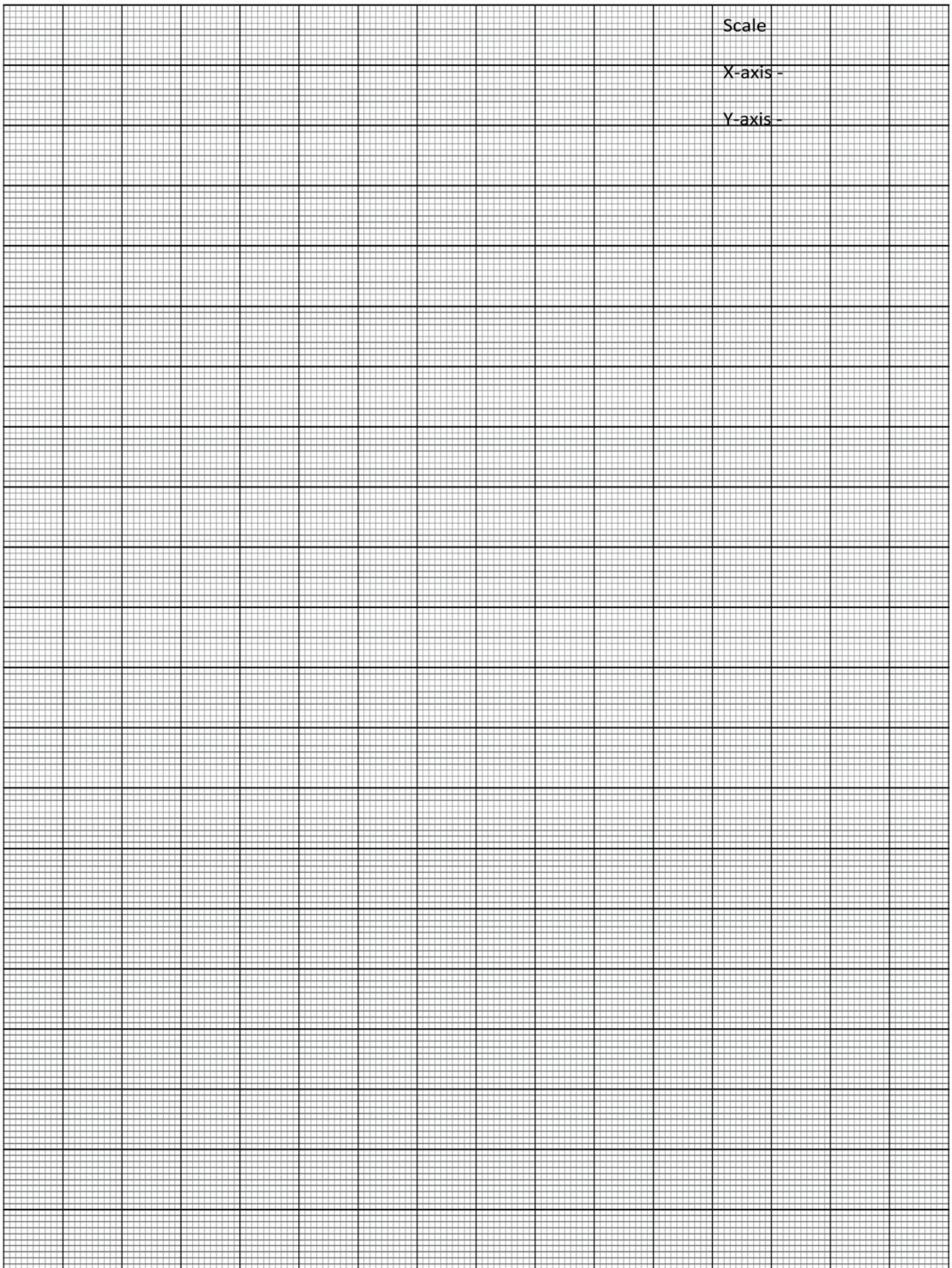

XIX Assessment Scheme:

Performance Indicators		Weightage
Process Related (15 Marks)		60%
01	Identification of different blocks on trainer kit	10%
02	Connection made on kit	20%
03	Observation and Measurement taken	20%
04	Handling of equipment and Working in team	10%
Product Related (10 Marks)		40%
05	Interpretation of Results	15%
06	Conclusions	05%
07	Practical Related Questions	15%
08	Submission of Journal in time	05%
Total (25 Marks)		100 %

Marks Obtained			Dated Signature of Teacher
Process Related (15)	Product Related (10)	Total (25)	

Practical No. 03: Performance of given Hi- Fi Amplifier

I Practical Significance

High Fidelity means Faithful reproduction of sound signal. It is widely used in the Public Address System, Stereo phony system. The High Fidelity system needs careful design from microphone to amplifier, used in recording mechanism, play back mechanism to get natural sound.

II Industry / Employer Expected outcome(s):

The aim of this practical is to attend the following industry/employer expected outcome through various teaching learning experiences.

Maintain various consumer electronic appliances/equipment.

III Course Level Learning outcome(s)

- Maintain the given type of audio system.

IV Laboratory Learning outcome(s)

- Measure voltages at different sections of Hi-Fi amplifier.

V Relevant Affective Domain related outcome(s)

1. Handle Hi-Fi. Amplifier kit carefully.
2. Select CRO/DSO for voltage and Frequency measurement.

VI Relevant Theoretical Background.

Hi-Fi amplifiers are widely used to reproduce sound signals which are similar to the original sound signal which is applied to input of Hi-Fi amplifiers. It consists of a pre amplifier for voltage amplification equalizer to select the required frequency and a power amplifier to amplify the power of signal to get the original sound signal.

Different stages of Hi-Fi amplifier: -

- 1 Input stage: Input can be from Tape play/Disc Play/Microphone.
- 2 Pre amplifiers stage: -Used to increase voltage level of Audio signal
- 3 Equalizers: Used to divide input frequency equally.
- 4 Amplifier stage: Used to increase power level of signal
- 5 Balance Control: Used to provide equal amount of current in both channel.
- 6 Matching N/W: Used to provide maximum power to the Loudspeaker.
- 7 Loud Speaker: Used to convert Electrical Audio Signal to Sound Signal

VII Circuit diagram used in a laboratory with related equipment rating.
a. Suggested Kit / Circuit Diagram:



Figure 3.1:Hi-Fi Amplifier Kit

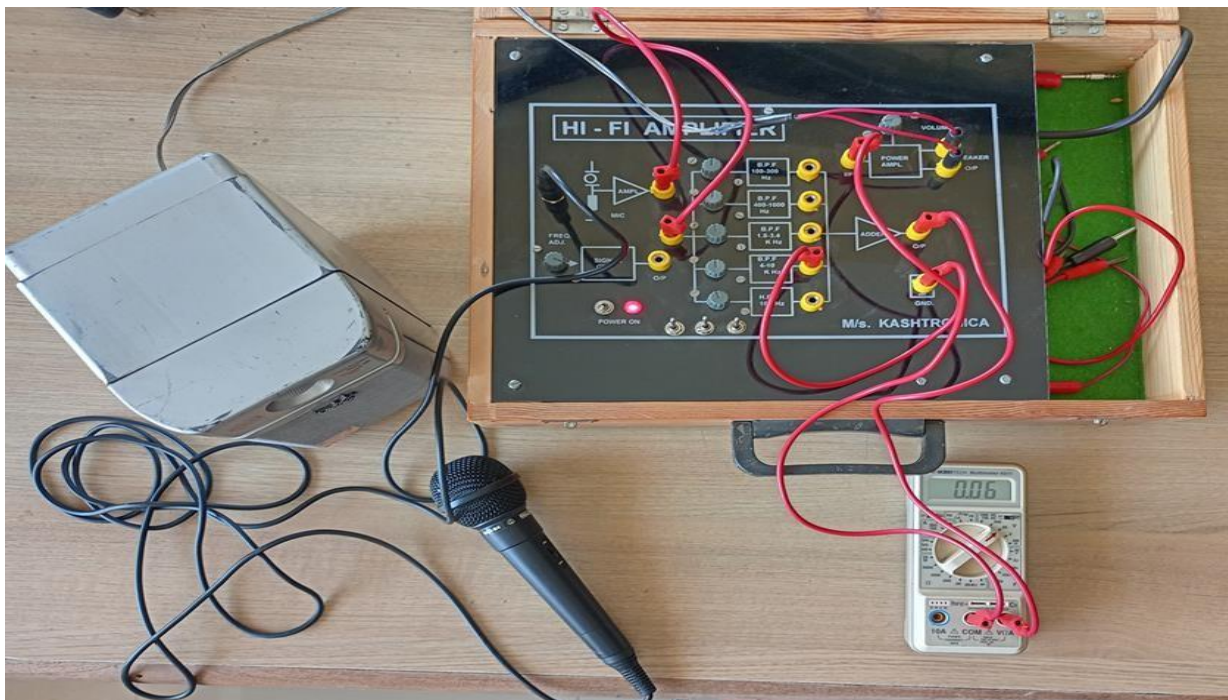

Figure 3.2: Hi-Fi Amplifier Kit with MIC and Speaker connection

b. Actual circuit diagram/Kit used in the laboratory:**VIII Required Resources/apparatus/equipment with specifications:**

Sr. No.	Instruments/Components	Specifications	Quantity
01	Hi-Fi amplifier Kit	Using IC 741 and LM 380	01
02	CRO	20 MHz Dual slope	01
03	Multi-meter	Digital Multi-meter: 3&1/2 digit display.	01
04	Connecting Cords/Wires	As per requirement	-

IX Precautions to be followed (Safety instructions / Rules / Standards)

- 1 Do not switch on the power supply unless you have checked the circuit connection as per circuit diagram.
- 2 Select the proper ranges of CRO and multi-meter.

X Procedure

- 1 Connect the given microphone to the Input connection of MIC.
- 2 Connect the given speaker to the output of the power amplifier.
- 3 Connect signal generator to the input of the filter & adder circuit. Keep the signal generator pot at the minimum position.
- 4 Keep pots of all four Band Pass Filter (BPF) and High Pass Filter (HPF) at maximum position.
- 5 Switch on Power Supply.
- 6 Observe input voltage at BPF stage.
- 7 Observe output on CRO at adder output and record the reading.
- 8 Observe the output at the power amplifier output stage and record the reading.
- 9 Keep a pot of BPF of range 1.5 to 3.4 Khz at minimum position and repeat steps 6 to 8 .
- 10 Repeat step 6 to 8 for different positions of pots of BPF to observe the response of the amplifier.

XI Required Resources:

Sr. No.	Instruments/Components	Specifications	Quantity

XII Actual procedure followed

.....

.....

.....

.....

.....

.....

.....

.....

.....

XIII Observation table

Sr. No.	Stage Name	AC Voltage In Volts	Frequency In Hz	Nature of Wave form
01	Input			
02	Equalizer or Adder output			
03	Power Amplifier output			

XIV Result(s):

.....

.....

XV Interpretation of Results:

.....

.....

XVIII References/Suggestions for further reading: include websites/links/Virtual lab Link

- 1 Manual of Kashtronica-kit
- 2 <https://www.hackatronic.com/lm380-audio-power-amplifier-circuit-and-its-working>
- 3 <https://www.circuits-diy.com/stereo-amplifier-circuit-using-lm380/>

XIX Assessment Scheme:

Performance Indicators		Weightage
Process Related (15 Marks)		60%
01	Identification of different blocks on trainer kit	10%
02	Connection made on kit	20%
03	Observation and Measurement taken	20%
04	Handling of equipment and Working in team	10%
Product Related (10 Marks)		40%
05	Interpretation of Results	15%
06	Conclusions	05%
07	Practical Related Questions	15%
08	Submission of Journal in time	05%
Total (25 Marks)		100 %

Marks Obtained			Dated Signature of Teacher
Process Related (15)	Product Related (10)	Total (25)	

Practical No. 04: Fault identification in Hi-Fi amplifier

I Practical Significance:

Troubleshooting a hi-fi amplifier involves a systematic approach to diagnose and resolve issues. It involves following steps:

Initial inspection.

- 1 Basic check
- 2 Functional testing
- 3 Component inspection.
- 4 Multi-meter Testing

By following proper troubleshooting procedures, issues can be resolved with a hi-Fi amplifier, ensuring optimal performance and longevity of audio equipment.

II Industry / Employer Expected outcome(s)

The aim of this practical is to attend the following industry/employer expected outcome through various teaching learning experiences.

Maintain various consumer electronic appliances/equipment.

III Course Level Learning outcome(s)

- Maintain the given type of audio system.

IV Laboratory Learning outcome(s)

- Locate any three different faults by voltage analysis method in a HI-FI audio amplifier.

V Relevant Affective Domain related outcome(s)

1. Handle Hi-Fi. Amplifier kit carefully
2. Select CRO/DSO for voltage and Frequency measurement.
3. Check continuity of circuit
4. Identify faulty section and also component

VI Relevant Theoretical Background.

Hi-Fi amplifiers consist of pre-amplifier for voltage amplification equalizer to select required frequency and Power amplifier to amplify power of signal to get original sound signal. The circuit diagram of above stages, their output voltages and its operation must be known. Identification of circuit components and their testing must be known.

Different stages of Hi-Fi amplifier: -

Input stage: Input can be from Tape play/Disc Play/Microphone.

1. Pre amplifiers stage: -Used to increase voltage level of Audio signal.
2. Equalizers: Used to divide input frequency equally.
3. Amplifier stage: Used to increase power level of signal

4. Balance Control: Used to provide equal amount of current in both channel.
5. Matching N/W: Used to provide maximum power to the Loudspeaker.
6. Loud Speaker: Used to convert Electrical Audio Signal to Sound Signal

VII Circuit diagram used in a laboratory with related equipment rating.

a. Suggested Kit / Circuit Diagram:



Figure 4.1:Hi-Fi Amplifier Kit

b. Actual setup diagram

VIII Required Resources/apparatus/equipment with specifications:

Sr. No.	Instruments/Components	Specifications	Quantity
01	Hi-Fi amplifier Kit	Using IC 741 and LM 380	01
02	CRO	20 MHz Dual slope	01
03	Multi-meter	Digital Multi-meter: 3&1/2 digit display.	01
04	Connecting Cords/Wires	As per requirement	-

IX Precautions to be followed (Safety instructions / Rules / Standards)

- 1 Do not switch on the power supply unless you have checked the circuit connection as per circuit diagram.
- 2 Select the proper ranges of CRO and multi-meter.

X Procedure:

- 1 Connect the given microphone to the Input connection of MIC.
- 2 Connect the given speaker to the output of the power amplifier.
- 3 Connect signal generator to the input of the filter & adder circuit. Keep the signal generator pot at the minimum position.
- 4 Keep pots of all four Band Pass Filter (BPF) and High Pass Filter (HPF) at maximum position.
- 5 Switch on Power Supply.
- 6 Three switches are given at the bottom of the KIT to indicate fault in MIC section, adder section and in power amplifier section.
- 7 For normal operation of an amplifier, always keep these switches in upward direction.
- 8 To indicate fault in the MIC section, keep the first switch in downward direction and observe the output at MIC section.
- 9 To indicate fault in the adder section, keep the second switch in downward direction and observe the output at adder section.
- 10 To indicate fault in the power amplifier section, keep the third switch in downward direction and observe the output at power amplifier.

XI Required Resources:

Sr. No.	Instruments/Components	Specifications	Quantity

XVI Conclusions and Recommendation

- 1 Fault created in the MIC section gives results as _____. (no output / partial output)
- 2 Fault created in speaker and volume control gives the result as _____ and _____ respectively. (Disturbance, no output / impedance, partial output)
- 3 Fault created in adder section gives result as __(No output at MIC/ NO output at speaker.)

XVII Practical Related Questions

Note: Below given are few sample questions. Teachers must design such questions to ensure achievement of identified CO.

- 1 What is a Hi Fi amplifier?
- 2 Draw block diagram of PA System
- 3 State characteristics of HI-FI amplifier.
- 4 Give a troubleshooting method for HI-FI amplifiers.

[Space for Answers]

.....

.....

.....

.....

.....

.....

.....

.....

.....

.....

.....

.....

.....

.....

.....

.....

.....

.....

.....

.....

.....

.....

.....

.....

.....

.....

.....

XVIII References/Suggestions for further reading: include websites/ links/Virtual lab Link

- 1 <https://www.hackatronic.com/lm380-audio-power-amplifier-circuit-and-its-working/>
- 2 <https://www.circuits-diy.com/stereo-amplifier-circuit-using-lm380/>
- 3 <https://hifiaudiolab.com/how-to-troubleshoot-common-hi-fi-system-problems/#:~:text=>

XIX Assessment Scheme:

Performance Indicators		Weightage
Process Related (15 Marks)		60%
01	Identification of different blocks on trainer kit	10%
02	Connection made on kit	20%
03	Observation and Measurement taken	20%
04	Handling of equipment and Working in team	10%
Product Related (10 Marks)		40%
05	Interpretation of Results	15%
06	Conclusions	05%
07	Practical Related Questions	15%
08	Submission of Journal in time	05%
Total (25 Marks)		100 %

Marks Obtained			Dated Signature of Teacher
Process Related (15)	Product Related (10)	Total (25)	

Practical No. 5: Test the CCTV Unit

I Practical Significance:

CCTV cameras and DVR/NVR systems require specific voltage levels to operate correctly. Testing ensures that each component receives the correct voltage, preventing malfunction or intermittent performance issues. Insufficient voltage can cause cameras to function improperly, leading to poor video quality, intermittent connectivity, or complete failure. By testing, you can ensure the system operates within its optimal voltage range.

II Industry / Employer Expected outcome(s)

The aim of this practical is to attend the following industry/employer expected outcome through various teaching learning experiences.

Maintain various consumer electronic appliances/equipment.

III Course Level Learning outcome(s)

- Test different types of video systems.

IV Laboratory Learning outcome(s)

- Measure the voltages of various components of CCTV unit.

V Relevant Affective Domain related outcome(s)

1. Note all voltage readings properly and ensure that all measurements are accurate and precise.
2. Inspect the equipment for safety before beginning the voltage testing procedure.

VI Relevant Theoretical Background.

Closed-circuit television (CCTV), also known as video surveillance, is the use of video cameras to transmit a signal to a specific place, on a limited set of monitors. It differs from broadcast television in that the signal is not openly transmitted, though it may employ point to point (P2P), point to multipoint (P2MP), or mesh wired or wireless links. Though almost all video cameras fit this definition, the term is most often applied to those used for surveillance in areas that may need monitoring such as banks, stores, and other areas where security is needed.

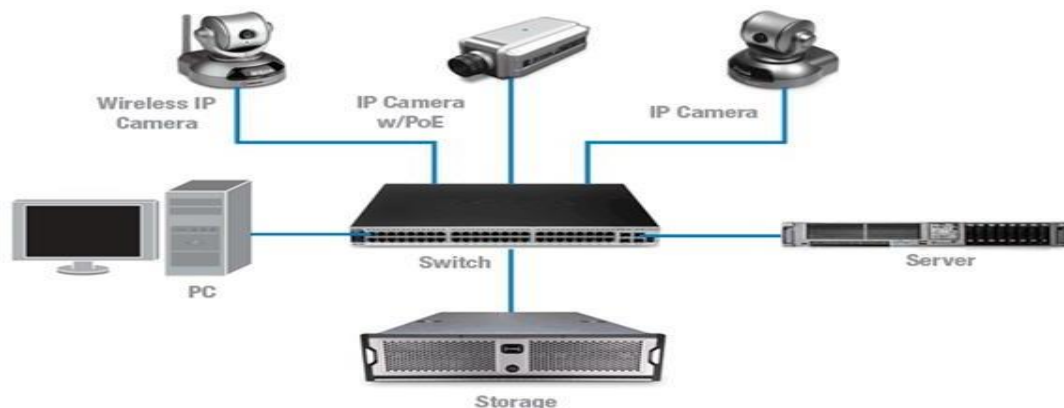

Figure 5.1 CCTV Unit using DVR

**VII Circuit diagram used in a laboratory with related equipment rating.
a Suggested Kit / Circuit Diagram:**

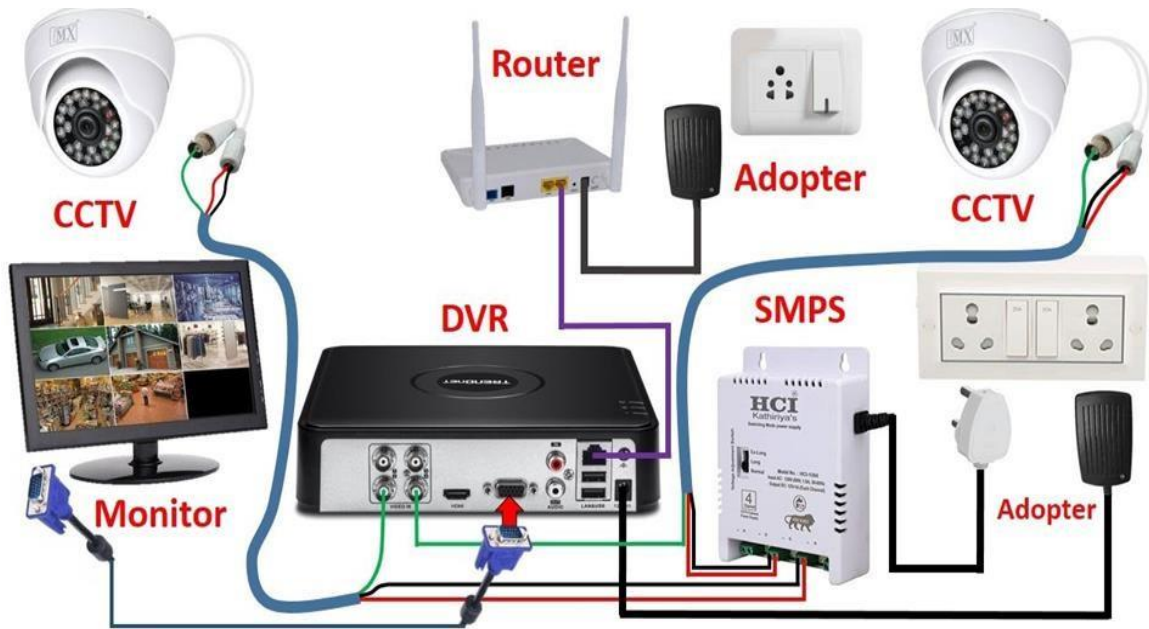

Figure 5.2. CCTV Unit using DVR

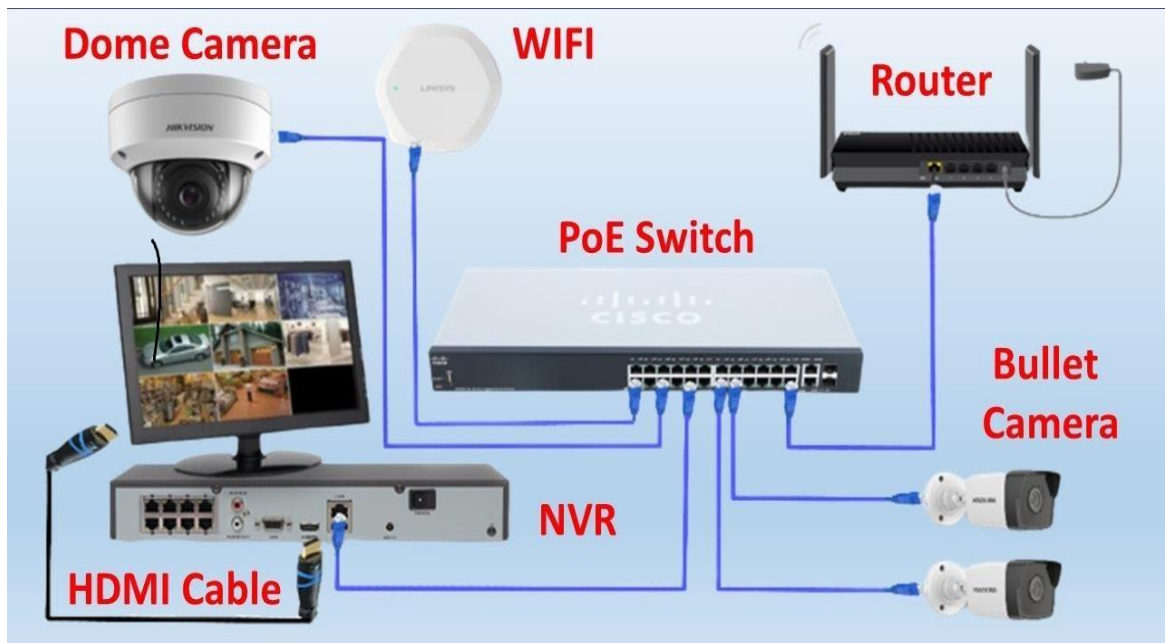

Figure 5.3 CCTV Unit using NVR

b. Actual circuit diagram/Kit used in the laboratory:**VIII Required Resources/apparatus/equipment with specifications:**

Sr. No.	Instruments/Components	Specifications	Quantity
01	CCTV Unit	Build in battery: 3.7 volt 3000 mAH, Power Output: 12V DC, Resolution: 480x234, Screen Size: 3.5 Inch.	01
02	IR Dome Camera	Voltage 12 V to 16 V, Lens optical, zoom - 30x-129 mm	01
03	4 CH DVR/NVR	MPEG 4	01
04	Hard Disk	1 TB	01
05	Video Cable	Strand diameter 0.1+mm	01
06	Power Supply	Input voltage 150 v to 240 v, output voltage 12 v	01
07	Digital Multi-meter	Digital Multi-meter: 3&1/2 digit display.	01

IX Precautions to be followed (Safety instructions / Rules / Standards)

- 1 Always turn off the power supply before connecting or disconnecting any parts of the CCTV system to avoid electric shocks or short circuits.
- 2 Hold the probes by their insulated handles. Avoid touching the metal parts of probes to prevent electric shock.
- 3 When measuring voltage at camera inputs or DVR inputs, ensure the cameras are properly mounted and stable to avoid accidental disconnection.

X Procedure:

Test the wires/cables/Electronic Components used for connections properly. If they are faulty then keep it in the proper E-waste bin.

1. Testing the Power Supply:

Step 1: Connect the multimeter probes to the output terminals of the CCTV power supply.

Step 2: Set the multimeter to measure DC voltage.

Step 3: Turn on the power supply and note the voltage reading. It should match the voltage rating specified on the power supply (usually 12V or 24V DC).

2. Testing Voltage at the CCTV Camera:

Step 1: Locate the power input terminals or connector on the CCTV camera.

Step 2: With the power supply turned on, use the multimeter to measure the voltage at the camera’s power input terminals.

Step 3: Verify that the voltage matches the camera’s required operating voltage (typically 12V or 24V DC).

3. Testing Voltage at the DVR/NVR:

Step 1: Locate the power input connector on the DVR/NVR.

Step 2: With the power supply turned on, use the multimeter to measure the voltage at the DVR/NVR’s power input.

Step 3: Ensure the voltage reading is consistent with the DVR/NVR’s required operating voltage (usually 12V or 19V DC).

XI Required Resources

Sr. No.	Instruments/Components	Specifications	Quantity
1			
2			
3			
4			

XII Actual procedure followed

.....

.....

.....

.....

.....

.....

.....

.....

.....

.....

.....

.....

.....

.....

.....

XIII Observation table:

Measurement Point	Expected Voltage (V)	Measured Voltage (V)	Difference (V)	Remark
Power Supply output	12 V			
Camera Input	12 V			
DVR Input	12 V			
Junction Box input	12 V			

XIV Result(s):

The voltages measured at different points should be _____ (within/out of) the specified range for each component.

XV Interpretation of Results:

.....

.....

XVI Conclusions and Recommendations:

.....

.....

XVIII References/Suggestions for further reading:

- 1 <https://images.app.goo.gl/XJfstz8FqhCQcL2F6>
- 2 <https://images.app.goo.gl/szBn8pwzYjWfawk96>

XIX Assessment Scheme

Performance Indicators		Weightage
Process Related (15 Marks)		60%
01	Identification of different blocks on trainer kit	10%
02	Connection made on kit	20%
03	Observation and Measurement taken	20%
04	Handling of equipment and Working in team	10%
Product Related (10 Marks)		40%
05	Interpretation of Results	15%
06	Conclusions	05%
07	Practical Related Questions	15%
08	Submission of Journal in time	05%
Total (25 Marks)		100 %

Marks Obtained			Dated Signature of Teacher
Process Related (15)	Product Related (10)	Total (25)	

Practical No. 6: Connection of CCTV cameras to DVR/IVR

I Practical Significance:

The connection of CCTV cameras to DVR/IVR systems significantly enhances security measures, operational efficiency, and the ability to respond to and investigate incidents effectively. These systems provide a robust and scalable solution for a variety of settings, from small businesses to large-scale industrial facilities.

II Industry / Employer Expected outcome(s)

The aim of this practical is to attend the following industry/employer expected outcome through various teaching learning experiences.

Maintain various consumer electronic appliances/equipment.

III Course Level Learning outcome(s)

- Test different types of video systems.

IV Laboratory Learning outcome(s)

- Connect CCTV cameras to DVR/IVR, record and replay.

V Relevant Affective Domain related outcome(s)

1. Understand the role of CCTV and DVR/IVR systems in enhancing safety and security.
2. Inspect the equipment for safety before making any connections.

VI Relevant Theoretical Background:

CCTV is a closed video surveillance system where video signals are transmitted to specific monitors or recording devices. Key components include cameras, monitors, recording devices (DVR/NVR), and cables or network infrastructure.

The main difference between the network video recorder (NVR) and digital video recorder (DVR) is in how they process raw video data. A DVR converts analog footage into a digital format, while an NVR typically only works with digital footage. DVR systems process data at recorder, while NVR systems encode and process data at the camera before transmitting it to the recorder for storage and remote viewing.

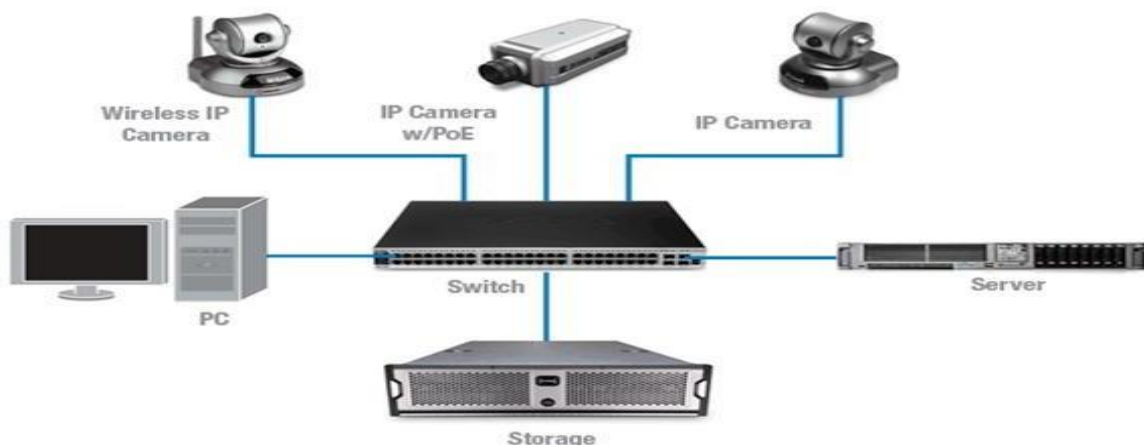

Figure 6.1 CCTV Unit

VII Circuit diagram used in a laboratory with related equipment rating.
a. Suggested Kit / Circuit Diagram:

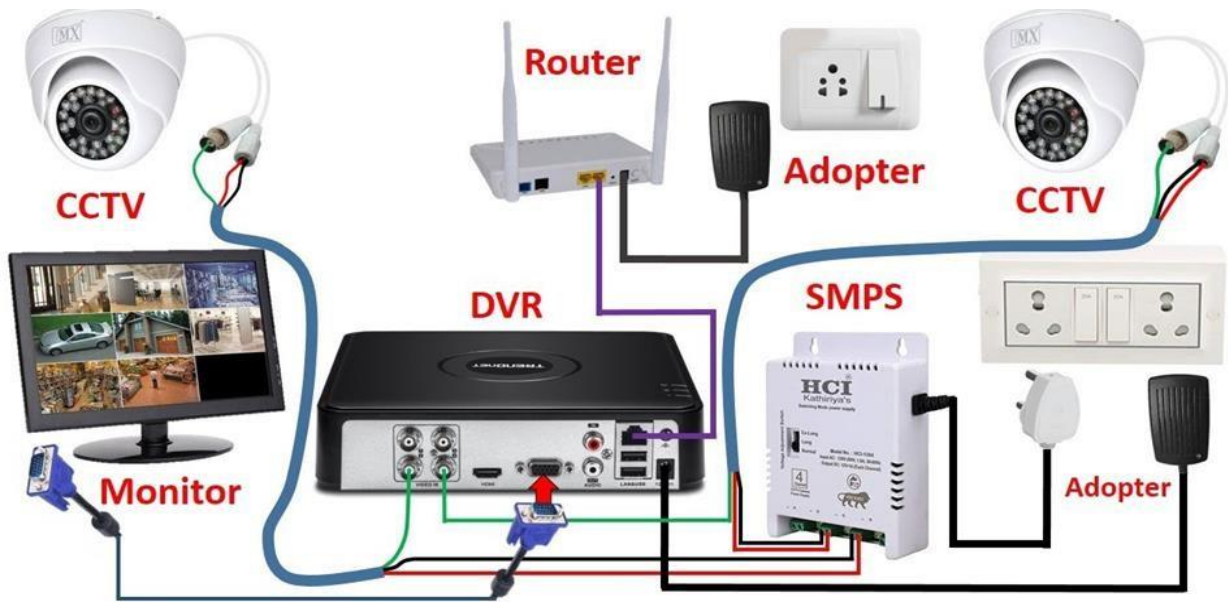

Figure 6.2 CCTV Unit

b. Actual circuit diagram/Kit used in the laboratory:

VIII Required Resources/apparatus/equipment with specifications:

Sr. No.	Instruments/Components	Specifications	Quantity
01	CCTV Unit	Build in battery: 3.7 volt 3000 mAH, Power Output: 12V DC, Resolution: 480x234, Screen Size: 3.5 Inch.	01
02	DVR (for analog cameras) or NVR (for IP cameras)	4 Ch,32 kbps–6144 kbps per channel 4 Ch, 80 Mbps for access	01
03	Coaxial cables (for analog cameras) Ethernet cables (for IP cameras)	RG 59	-
04	Multimeter	Digital ,31/2 digit display,9999	01

IX Precautions to be followed (Safety instructions / Rules / Standards)

1. Always turn off the power supply before connecting or disconnecting any parts of the CCTV system to avoid electric shocks or short circuits.
2. Hold the probes by their insulated handles. Avoid touching the metal parts of the probes to prevent electric shock.
3. When measuring voltage at camera inputs or DVR inputs, ensure the cameras are properly mounted and stable to avoid accidental disconnection.

X Procedure:

Test the wires/cables/Electronic Components used for connections properly. If they are faulty then keep it in the proper E-waste bin.

Procedure for Connecting CCTV Cameras to DVR (Analog System):

- 1. Prepare the Equipment:**
Unbox the DVR and cameras.
Check all components are present and undamaged.
- 2. Camera Placement:**
Determine optimal locations for camera placement.
Mount the cameras securely using the provided brackets and screws.
- 3. Running the Coaxial Cables:**
Measure the distance from each camera to the DVR.
Cut coaxial cables to the required lengths.
Run the cables from each camera to the DVR location, securing them with cable ties or clips.
- 4. Connecting the Cameras to the DVR:**
Connect the BNC connectors on the coaxial cables to the cameras and the DVR.

If the cameras are not powered by the coaxial cable, run separate power cables and connect them to a power source.

5. Powering Up the System:

Plug in the power supply for the DVR.

Connect the DVR to a monitor using an HDMI or VGA cable.

Power on the DVR and the monitor.

6. Configuring the DVR:

Follow the on-screen setup wizard to configure the DVR (date, time, recording schedule, etc.).

Adjust camera settings (resolution, frame rate) as needed.

Ensure each camera feed is displayed correctly on the monitor.

7. Testing the System:

Check the live feed from each camera on the monitor.

Verify that the DVR is recording and storing footage properly.

Test playback functionality to ensure recordings can be accessed.

Procedure for Connecting CCTV Cameras to NVR (IP System):

1. Prepare the Equipment:

Unbox the NVR and IP cameras.

Check all components are present and undamaged.

2. Camera Placement:

Determine optimal locations for camera placement.

Mount the cameras securely using the provided brackets and screws.

3. Running the Ethernet Cables:

Measure the distance from each camera to the NVR or network switch/router.

Cut Ethernet cables to the required lengths.

Run the cables from each camera to the NVR location or the network switch/router, securing them with cable ties or clips.

4. Connecting the Cameras to the Network:

Connect one end of each Ethernet cable to the cameras and the other end to the NVR or network switch/router.

If using PoE, ensure the NVR or switch/router supports PoE and the Ethernet cables are properly connected to provide power to the cameras.

5. Powering Up the System:

Plug in the power supply for the NVR.

Connect the NVR to a monitor using an HDMI or VGA cable.

Power on the NVR and the monitor.

6. Configuring the NVR:

Follow the on-screen setup wizard to configure the NVR (date, time, recording schedule, etc.).

The NVR should automatically detect and configure the connected IP cameras.

Adjust camera settings (resolution, frame rate) as needed.

7. Testing the System:

Check the live feed from each camera on the monitor.

Verify that the NVR is recording and storing footage properly.

Test playback functionality to ensure recordings can be accessed.

8. Network Configuration (if necessary):

Assign static IP addresses to each camera for stable network performance. Configure remote access settings if you need to view the camera feeds from outside the local network (e.g., through a mobile app or web interface).

XI Required Resources

Sr. No.	Instruments/Components	Specifications	Quantity

XII Actual procedure followed

.....

.....

.....

.....

.....

.....

.....

.....

.....

.....

XIII Observation table:

Measurement Point	Expected Voltage (V)	Measured Voltage (V)	Difference (V)	Remark
Power Supply output	12 V			
Camera Input	12 V			
DVR Input	12 V			
Junction Box input	12 V			

XIV Result(s):

The voltages measured at different points should be _____ (within/out of) the specified range for each component.

XV Interpretation of Results:

.....
.....

XVI Conclusions and Recommendations:

.....
.....

XVII Practical Related Questions:

Note: Below given are few sample questions. Teachers must design such questions to ensure achievement of identified CO.

1. At what height are the cameras installed?
2. Which type of cable is used in experiment for connecting camera?
3. State any two features each of Analog and IP cameras.
4. How much storage capacity is needed for the recording device?

[Space for Answers]

.....
.....
.....
.....
.....
.....
.....
.....
.....
.....
.....
.....
.....
.....
.....
.....
.....
.....
.....
.....
.....

.....

.....

.....

.....

.....

.....

.....

.....

.....

.....

XVIII References/Suggestions for further reading: include websites/links/Virtual lab Link

- 1 <https://images.app.goo.gl/XJfstz8FqhCQcL2F6>
- 2 <https://images.app.goo.gl/szBn8pwzYjWfawk96>

XIX Assessment Scheme

Performance Indicators		Weightage
Process Related (15 Marks)		60%
01	Identification of different blocks on trainer kit	10%
02	Connection made on kit	20%
03	Observation and Measurement taken	20%
04	Handling of equipment and Working in team	10%
Product Related (10 Marks)		40%
05	Interpretation of Results	15%
06	Conclusions	05%
07	Practical Related Questions	15%
08	Submission of Journal in time	05%
Total (25 Marks)		100 %

Marks Obtained			Dated Signature of Teacher
Process Related (15)	Product Related (10)	Total (25)	

Practical No. 07: Voltage analysis of power supply section, audio section and video section of LCD TV

I Practical Significance:

Voltage analysis of the power supply, audio section, and video section of an LCD TV is critical for ensuring optimal performance, troubleshooting problems, protecting components, ensuring safety, optimizing energy efficiency, and maintaining quality standards throughout the manufacturing process.

II Industry / Employer Expected outcome(s)

The aim of this practical is to attend the following industry/employer expected outcome through various teaching learning experiences.

Maintain various consumer electronic appliances/equipment.

III Course Level Learning outcome(s)

- Test different types of video systems.

IV Laboratory Learning outcome(s)

- Measure voltage of power supply, audio and video section of LCD TV.
- Compare measured voltages with standard voltages.

V Relevant Affective Domain related outcome(s)

1. Handle equipment carefully.
2. Follow safety precautions.

VI Relevant Theoretical Background.

An LCD screen includes a thin layer of liquid crystal material sandwiched between two electrodes on glass substrates, with two polarizers on each side. A polarizer is an optical filter that lets light waves of a specific polarization pass through while blocking light waves of other polarizations. The electrodes need to be transparent, so the most popular material is ITO (Indium Tin Oxide).

As LCD can't emit light itself, normally a backlight is placed behind an LCD screen in order to be seen during the dark environment. The light sources for backlight can be LED (Light Emitting Diode) or CCFL (Cold Cathode Fluorescent Lamps). LED backlights are the most popular. Of course, if you like to have a color display, a layer of color filter can be made into an LCD cell. The color filter consists of RGB color. You can also add a touch panel in front of an LCD.

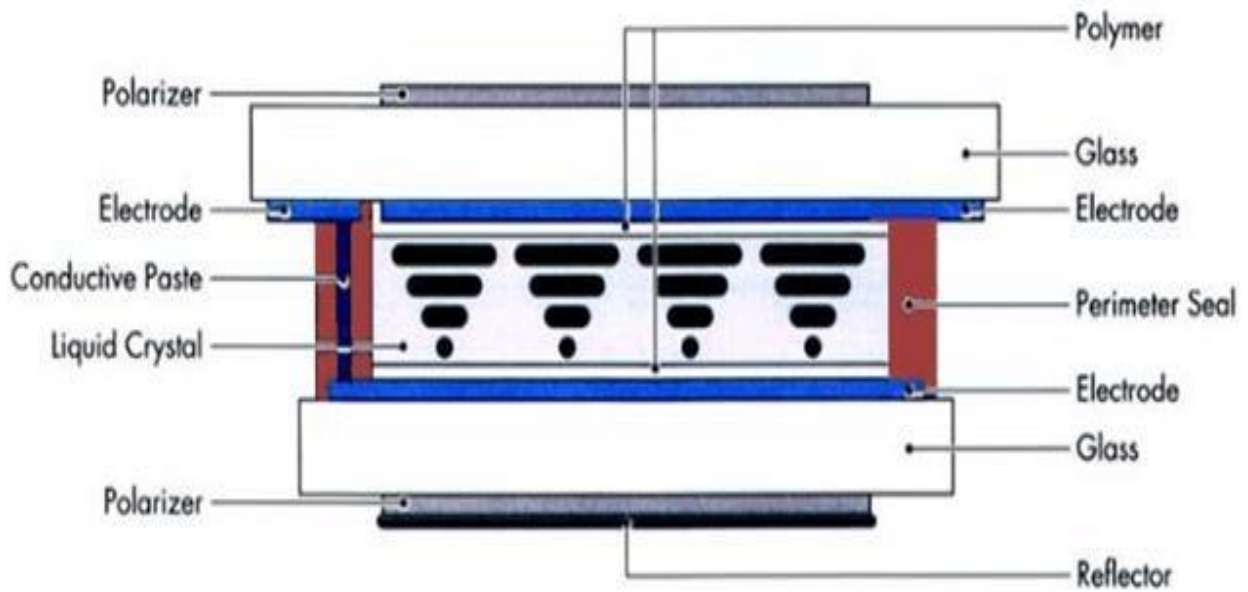

Figure 7.1. LCD display Structure

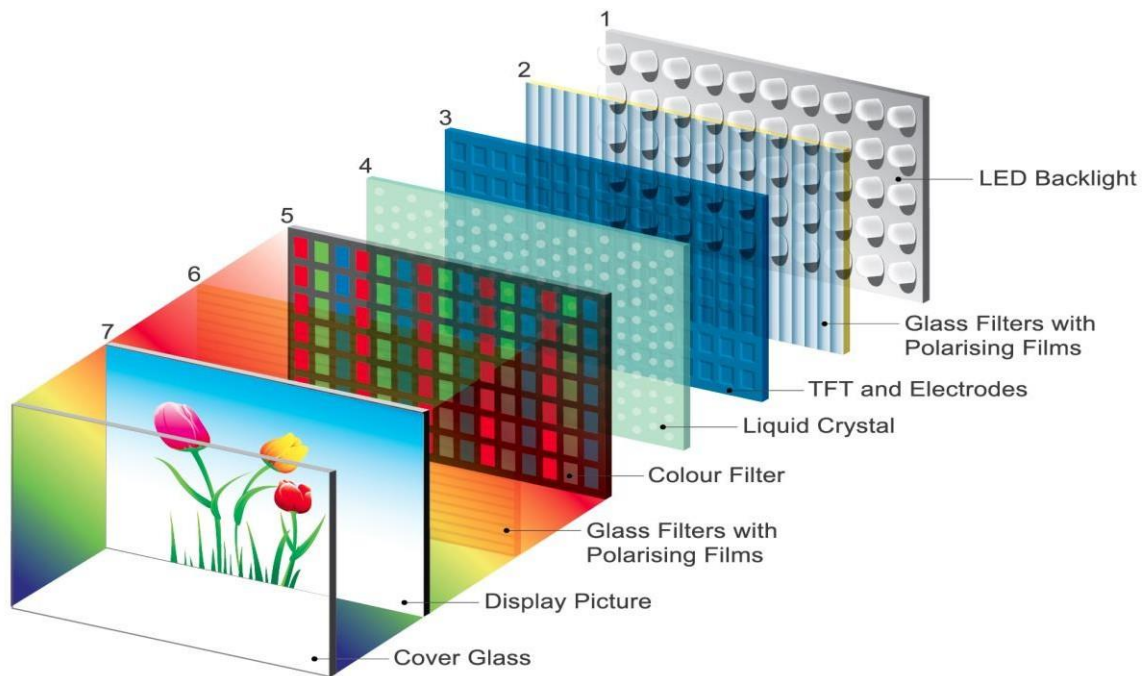

Figure 7.2. LCD TV parts diagram

VII LCD TV trainer kit diagram used in a laboratory with related equipment rating.
a Suggested Kit / Circuit Diagram:



Figure 7.3. LCD TV trainer kit

b Actual setup diagram

VIII Required Resources/apparatus/equipment with specifications:

Sr. No.	Instruments/Components	Specifications	Quantity
01	LCD trainer Kit	Scientech kit or any other available in your laboratory	01
02	Multi-meter	Digital Multi-meter: 3&1/2 digit display.	01
03	Connecting Cords/Wires	As per requirement	-

IX Precautions to be followed (Safety instructions / Rules / Standards)

1. Do not switch on the power supply unless you have checked the circuit connection as per circuit diagram.
2. Select the proper range of Voltage of multi-meter.
3. Connect multi-meter probes with correct polarities to the kit for supply voltage measurements.
4. Keep kit in dust free and clean place

X Procedure:

1. Identify different stages of a given LCD TV receiver.
2. Observe the circuit diagram of LCD TV.
3. Identify various sections and write the function in the observation table.
4. Identify various stages of the LCD TV set and measure voltages with the help of a multi-meter and write in the observation table.

XI Required Resources

Sr. No.	Instruments/Components	Specifications	Quantity

XII Actual procedure followed

.....

.....

.....

XIII Observation table:

Sr. No.	Section	Main board power supply connector details	Standard voltages	Measured voltages	Function of section
1	Power Section	LED1+ : Driver Supply for LED Panel	+25 - 40V		
2		LED-: Ground for Driver Supply	0V		
3	Audio section	Power input to Sound Amplifier	+12V		
4	Video section	Power input to Tuner circuit	+3.3V		
5	Microprocessor section	Power input to Processor	+1.5 - 2V		
6	Sub microprocessor section	Power input for Stand By operation	+5V		
7		Power input to DRAM section	+3.3V		

XIV Result(s):

.....

.....

XV Interpretation of Results:

.....

.....

XVI Conclusions and Recommendations:

.....

.....

.....

XVIII References/Suggestions for further reading: include websites/links/Virtual lab Link

1. <https://youtu.be/TQmTSgUGS0I?si=H8GQdFsUhX1I6xNX>
2. <https://wiringdatateresa.z21.web.core.windows.net/lcd-tv-parts-diagram.html>
3. <https://www.scientechworld.com/education-software-training-and-skill-development/engineering-and-vocational-products/understanding-lcd-television>
4. <https://www.orientdisplay.com/knowledge-base/lcd-basics/what-is-lcd-liquid-crystal-display/>

XIX Assessment Scheme

Performance Indicators		Weightage
Process Related (15 Marks)		60%
01	Identification of different blocks on trainer kit	10%
02	Connection made on kit	20%
03	Observation and Measurement taken	20%
04	Handling of equipment and Working in team	10%
Product Related (10 Marks)		40%
05	Interpretation of Results	15%
06	Conclusions	05%
07	Practical Related Questions	15%
08	Submission of Journal in time	05%
Total (25 Marks)		100 %

Marks Obtained			Dated Signature of Teacher
Process Related (15)	Product Related (10)	Total (25)	

Practical No. 08: Fault analysis of LCD TV

I Practical Significance:

Fault analysis of LCD TVs involves diagnosing and troubleshooting issues that may arise during operation. It underscores the importance of systematic diagnosis and repair in ensuring the optimal performance, reliability, and longevity of LCD TVs.

II Industry / Employer Expected outcome(s)

The aim of this practical is to attend the following industry/employer expected outcome through various teaching learning experiences.

Maintain various consumer electronic appliances/equipment.

III Course Level Learning outcome(s)

- Test different types of video systems

IV Laboratory Learning outcome(s)

- Troubleshoot the faults in LCD TV: - a) No picture, No Audio.
b) No audio but proper picture.
c) complete dead TV.

V Relevant Affective Domain related outcome(s)

1. Handle equipment carefully.
2. Follow safety precautions.

VI Relevant Theoretical Background.

Here's an overview of the key theoretical concepts relevant to diagnosing and troubleshooting LCD TV issues:

1. LCD Structure and Operation:

- LCD panels consist of a sandwich-like structure with layers of polarizing filters, liquid crystal material, electrodes, and a backlight.
- Liquid crystals are molecules that can change orientation in response to an electric field, modulating the passage of light through the panel.
- Understanding how the application of voltage affects the orientation of liquid crystals helps diagnose issues related to display anomalies such as dead pixels, stuck pixels, or image persistence.

2. Backlighting:

- LCD TVs use various backlighting technologies, such as LED (Light Emitting Diode) or CCFL (Cold Cathode Fluorescent Lamp), to illuminate the screen.
- Issues with backlighting, such as dimness, flickering, or uneven illumination, can affect the overall brightness and uniformity of the display.

- Knowledge of backlighting systems and their components is essential for diagnosing faults related to power supply, inverter boards, or backlight assemblies.
3. Signal Processing and Mainboard:
 - The mainboard of an LCD TV houses components responsible for processing audio and video signals, driving the display panel, and controlling various functions.
 - Faults in signal processing circuits, such as damaged ICs (Integrated Circuits), faulty connections, or corrupted firmware, can lead to issues such as distorted images, color inaccuracies, or no display.
 - Understanding the signal flow and processing stages helps pinpoint faults within the mainboard and associated circuitry.
 4. Power Supply and Voltage Regulation:
 - The power supply unit (PSU) provides the necessary voltages to operate the various components of an LCD TV, including the backlight, mainboard, and peripherals.
 - Faults in the power supply, such as insufficient voltage output, voltage spikes, or ripple, can cause a range of issues, including intermittent power, no power, or erratic behavior.
 - Knowledge of voltage regulation, component tolerances, and protection mechanisms aids in diagnosing power supply-related faults accurately.
 5. Control Interfaces and User Input:
 - LCD TVs feature control interfaces such as buttons, remote controls, or touch panels for user interaction.
 - Issues with control interfaces, such as unresponsive buttons, erratic behavior, or communication errors, may stem from faulty components, loose connections, or firmware issues.
 - Understanding the operation of control interfaces and their integration with the mainboard helps diagnose and troubleshoot user input-related faults.
 6. Environmental Factors and Aging Effects:
 - Environmental factors such as temperature, humidity, and mechanical stress can affect the performance and longevity of LCD TVs.
 - Aging effects, such as degradation of components, wear and tear of connectors, or deterioration of backlighting elements, may manifest as gradual changes in display quality or intermittent faults.
 - Recognizing the impact of environmental factors and aging effects is essential for predicting and diagnosing long-term reliability issues in LCD TVs.

VII LCD TV trainer kit diagram used in a laboratory with related equipment rating.
a. Suggested Kit / Circuit Diagram:



Figure 8.1. LCD TV trainer kit

b. Actual setup diagram

VIII Required Resources/apparatus/equipment with specifications:

Sr. No.	Instruments/Components	Specifications	Quantity
01	LCD trainer Kit	Sciencetech kit or any other available in your laboratory	01
02	Multimeter	Digital Multi-meter: 3&1/2 digit display.	01
03	Connecting Cords/Wires	As per requirement	

IX Precautions to be followed (Safety instructions / Rules / Standards)

- 1 Do not switch on the power supply unless you have checked the circuit connection as per circuit diagram.
- 2 Select the proper range of Voltage of multi-meter.
- 3 Connect multi-meter probes with correct polarities to the kit for supply voltage measurements.
- 4 Keep kit in dust free and clean place

X Procedure:

- 1 Identify different stages of a given LCD TV receiver.
- 2 Observe the circuit diagram of LCD TV.
- 3 Identify various sections and write the function in the observation table.
- 4 Identify various stages of the LCD TV set and measure voltages with the help of a multi- meter and write in the observation table.

XI Required Resources

Sr. No.	Instruments/Components	Specifications	Quantity

XII Actual procedure followed

.....

.....

.....

XIII Observation table:

Sr. No.	Fault in Section	Observations
1	Power supply	
2	Audio/Video input	
3	Audio/Video output	
4	LCD display interface	
5	Totally unable to view screen / Blank screen	

XIV Result(s):

.....

XV Interpretation of Results:

.....

XVI Conclusions and Recommendations:

.....

XVII Practical Related Questions:

Note: Below given are few sample questions. Teachers must design such questions to ensure achievement of identified CO.

1. Outline the troubleshooting steps you would take to identify the cause of a no display fault in an LCD TV.
2. Explain the process of diagnosing and repairing backlight-related faults in an LCD TV.

XVIII References/Suggestions for further reading: include websites/links/Virtual lab Link

- 1 <https://youtu.be/TQmTSgUGS0I?si=H8GQdFsUhX1I6xNX>
- 2 <https://www.scientechworld.com/education-software-training-and-skill-development/engineering-and-vocational-products/understanding-lcd-television>

XIX Assessment Scheme

Performance Indicators		Weightage
Process Related (15 Marks)		60%
01	Identification of different blocks on trainer kit	10%
02	Connection made on kit	20%
03	Observation and Measurement taken	20%
04	Handling of equipment and Working in team	10%
Product Related (10 Marks)		40%
05	Interpretation of Results	15%
06	Conclusions	05%
07	Practical Related Questions	15%
08	Submission of Journal in time	05%
Total (25 Marks)		100 %

Marks Obtained			Dated Signature of Teacher
Process Related (15)	Product Related (10)	Total (25)	

Practical No. 09: Voltage analysis of given sections of LED TV.

I Practical Significance:

The main board is the central component of an LED TV and is responsible for controlling various functions, including signal processing, power distribution, and input/output connections. It is necessary to know the standard voltages at various stages for troubleshooting and repair.

II Industry / Employer Expected outcome(s)

The aim of this practical is to attend the following industry/employer expected outcome through various teaching learning experiences.

Maintain various consumer electronic appliances/equipment.

III Course Level Learning outcome(s)

- Test different types of video systems.

IV Laboratory Learning outcome(s)

- Test the performance of various sections of given LED TV:
a) Power Supply b) Driver LED section c) Audio section d) Video Section

V Relevant Affective Domain related outcome(s)

1. Handle equipment carefully.
2. Follow safety precautions.

VI Relevant Theoretical Background.

LED stands for "light-emitting diode," and an LED TV is a type of television that uses LED backlighting to produce images. The LED TV is a more advanced version of the LCD TV. It has an array of LED's to provide the backlight. LED's consist of small semiconductors, which glow during exposure to electric current. Specifically, this current flows between LED anodes which are positively charged electrodes, and LED cathodes which are negatively charged electrodes. LED TV requires less energy and is able to produce brighter on-screen colors than LCD TV.

VII LED TV trainer kit diagram used in a laboratory with related equipment rating.

a. Suggested Kit / Circuit Diagram:



Figure 9.1. LED TV trainer kit

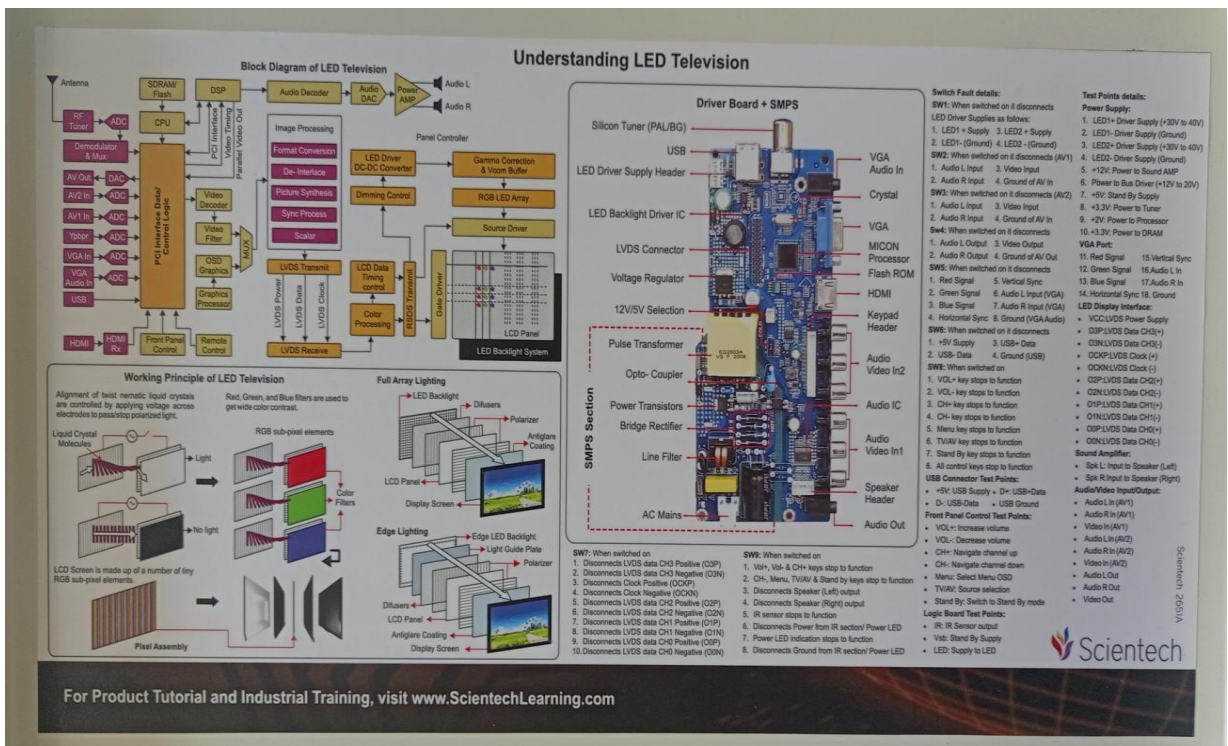

Figure 9.2. LED TV block diagram

b Actual circuit diagram/Kit used in the laboratory:**VIII Required Resources/apparatus/equipment with specifications:**

Sr. No.	Instruments/Components	Specifications	Quantity
01	LED trainer Kit	Sciencetech kit or any other available in your laboratory	01
02	Multimeter	Digital Multimeter: 3&1/2 digit display.	01
03	Connecting Cords/Wires	As per requirement	

XIX Precautions to be followed (Safety instructions / Rules / Standards)

1. Do not switch on the power supply unless you have checked the circuit connection as per circuit diagram.
2. Select the proper range of Volt/div and Time/div on CRO.
3. Connect kit and CRO with correct polarities.

X Procedure:

1. Identify different stages of a given LED TV receiver.
2. Observe the circuit diagram of LED TV.
3. Identify various sections and write the function in the observation table.
4. Identify various stages of the LED TV set and measure voltages with the help of a multimeter and write in the observation table.

XI Required Resources

Sr. No.	Instruments/Components	Specifications	Quantity

XII Actual procedure followed

.....

.....

.....

.....

XIII Observation table:**Standard voltages and frequencies:**

Sr. No.	Section	Main board power supply connector details	Standard voltages	Measured voltages	Function of section
1	Power Section	LED1+ : Driver Supply for LED Panel	+25 - 40V		
2		LED-: Ground for Driver Supply	0V		
3	Audio section	Power input to Sound Amplifier	+12V		
4	Video section	Power input to Tuner circuit	+3.3V		
5	Microprocessor section	Power input to Processor	+1.5 - 2V		
6	Sub microprocessor section	Power input for Stand By operation	+5V		
7		Power input to DRAM section	+3.3V		

XIV Result(s):

.....

.....

XV Interpretation of Results:

.....
.....

XVI Conclusions and Recommendations:

.....
.....

XVII Practical Related Questions:

Note: Below given are few sample questions. Teachers must design such questions to ensure achievement of identified CO.

1. Give standard voltage ranges of typical LED TV at audio and video sections input and output?
2. List the different sections of LED TV.
3. For television, which is better: LED or LCD, why?
4. Give the difference between LED TV and LCD TV.

[Space for Answers]

.....
.....
.....
.....
.....
.....
.....
.....
.....
.....
.....
.....
.....
.....
.....
.....
.....
.....
.....
.....
.....

XVII References/Suggestions for further reading: include websites/links/Virtual lab Link

1. <https://www.scientechworld.com/education-software-training-and-skill-development/engineering-and-vocational-products/understanding-lcd-television>
2. <https://www.soft4led.com/lcd-led-tv-display-panel-connection-voltages-understanding/>

XIX Assessment Scheme

Performance Indicators		Weightage
Process Related (15 Marks)		60%
01	Identification of different blocks on trainer kit	10%
02	Connection made on kit	20%
03	Observation and Measurement taken	20%
04	Handling of equipment and Working in team	10%
Product Related (10 Marks)		40%
05	Interpretation of Results	15%
06	Conclusions	05%
07	Practical Related Questions	15%
08	Submission of Journal in time	05%
Total (25 Marks)		100 %

Marks Obtained			Dated Signature of Teacher
Process Related (15)	Product Related (10)	Total (25)	

Practical No. 10: Fault analysis of LED TV

I Practical Significance:

The main board is the central component of an LED TV and is responsible for controlling various functions, including signal processing, power distribution, and input/output connections. When the main board malfunctions, it can result in various problems, such as no power, no picture, or even a completely dead TV. In such cases, it becomes necessary to test the main board to identify the underlying issue and troubleshoot the TV. Fault analysis of LED TVs involves diagnosing and troubleshooting issues that may arise during operation. It underscores the importance of systematic diagnosis and repair in ensuring the optimal performance, reliability, and longevity of LED TVs.

II Industry / Employer Expected outcome(s)

The aim of this practical is to attend the following industry/employer expected outcome through various teaching learning experiences.

Maintain various consumer electronic appliances/equipment.

III Course Level Learning outcome(s)

- Test different types of video systems

IV Laboratory Learning outcome(s)

- Locate and rectify faults in a LED TV: -
 - i. No picture, No Audio.
 - ii. No audio but proper picture.
 - iii. Complete dead TV.

V Relevant Affective Domain related outcome(s)

1. Handle equipment carefully.
2. Follow safety precautions.

VI Relevant Theoretical Background.

The LED TV is a more advanced version of the LCD TV. It has an array of LED's to provide the backlight. LED's consist of small semiconductors, which glow during exposure to electric current. Specifically, this current flows between LED anodes which are positively charged electrodes, and LED cathodes which are negatively charged electrodes. LED TV requires less energy and is able to produce brighter on-screen colors than LCD TV.

VII LED TV trainer kit diagram used in a laboratory with related equipment rating.

a. Suggested Kit / Circuit Diagram:



Figure 10.1. LED TV trainer kit

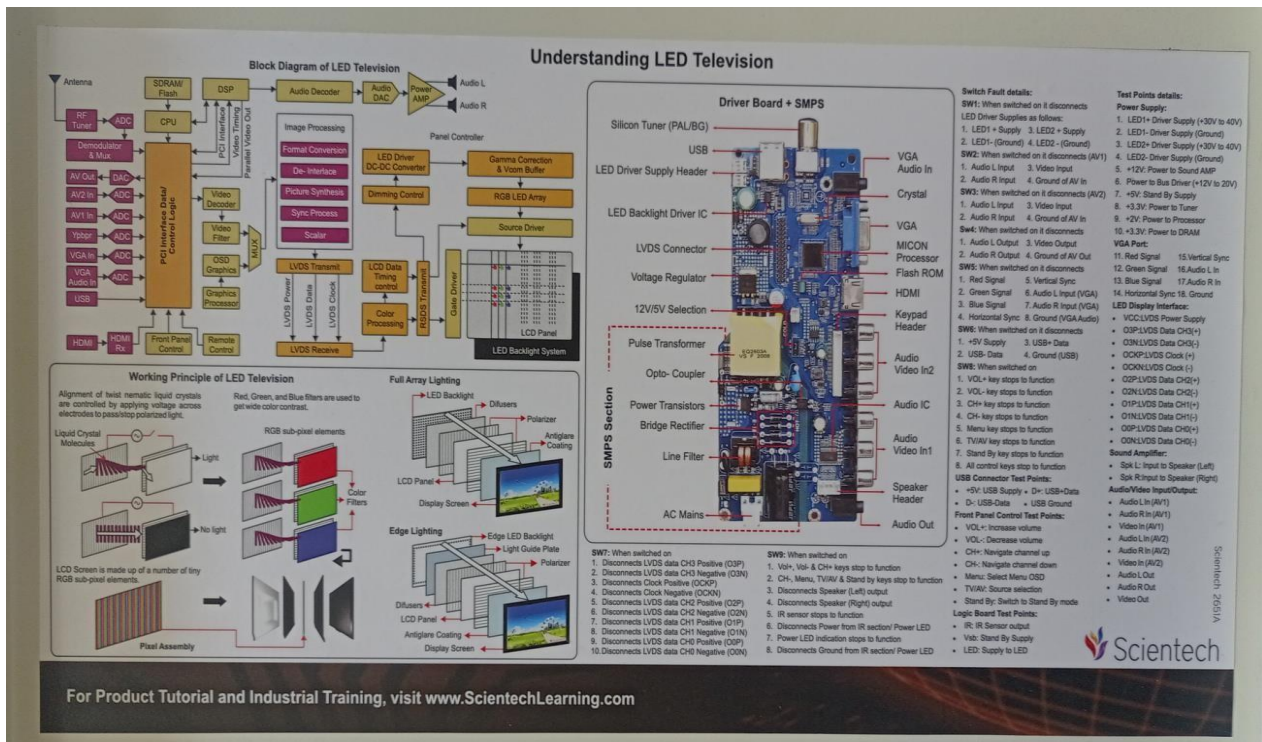

Figure 10.2. LED TV block diagram

b. Actual Circuit diagram/Kit used in a laboratory with related equipment rating.**VIII Required Resources/apparatus/equipment with specifications:**

Sr. No.	Instruments/Components	Specifications	Quantity
01	LED trainer Kit	Sciencetech kit or any other available in your laboratory	01
02	Multimeter	Digital Multi-meter: 3&1/2 digit display.	01
03	Connecting Cords/Wires	As per requirement	01

IX Precautions to be followed (Safety instructions / Rules / Standards)

1. Do not switch on the power supply unless you have checked the circuit connection as per circuit diagram.
2. Select the proper range of Volt/div and Time/div on CRO.
3. Connect kit and CRO with correct polarities.

X Procedure:

1. Identify different stages of a given LED TV receiver.
2. Observe the circuit diagram of LED TV.
3. Identify various sections and write the function in the observation table.
4. Identify various stages of the LED TV set and measure voltages with the help of a multi-meter and write in the observation table.

XI Required Resources

Sr. No.	Instruments/Components	Specifications	Quantity

XII Actual procedure followed

.....

XIII Observation table:

Sr. No	Fault in Section	Observations
1	Power supply	
2	Audio/Video input	
3	Audio/Video output	
4	LED display interface	
5	Totally unable to view screen	

XIV Result(s):

.....

XV Interpretation of Results:

.....

XVIII References/Suggestions for further reading: include websites/links/Virtual lab Link

- 1 <https://youtu.be/6OPrb9Gdf9Y>
- 2 <https://www.scientechworld.com/education-software-training-and-skill->

XIX Assessment Scheme

Performance Indicators		Weightage
Process Related (15 Marks)		60%
01	Identification of different blocks on trainer kit	10%
02	Connection made on kit	20%
03	Observation and Measurement taken	20%
04	Handling of equipment and Working in team	10%
Product Related (10 Marks)		40%
05	Interpretation of Results	15%
06	Conclusions	05%
07	Practical Related Questions	15%
08	Submission of Journal in time	05%
Total (25 Marks)		100 %

Marks Obtained			Dated Signature of Teacher
Process Related (15)	Product Related (10)	Total (25)	

Practical No. 11: Dismantling and assembling of paper feed mechanism in photocopier machine

I Practical Significance:

Dismantling and reassembling the paper feed mechanism helps technicians and engineers understand how each component functions and interacts within the system. It enhances technical skills and practical knowledge, which are critical for maintenance and servicing of photocopier machines. Understanding the common failure points allows for better preventive maintenance strategies, reducing downtime and extending the life of the machine. Ensuring that the paper feed mechanism is properly tested and reassembled maintains the quality of the photocopying process, reducing the likelihood of paper jams or misfeeds

II Industry / Employer Expected outcome(s)

The aim of this practical is to attend the following industry/employer expected outcome through various teaching learning experiences.

Maintain various consumer electronic appliances/equipment.

III Course Level Learning outcome(s)

- Troubleshoot various consumer electronic appliances.

IV Laboratory Learning outcome(s)

- Test the components and operation of the paper feed mechanism in a photocopier machine through dismantling and reassembly.

V Relevant Affective Domain related outcome(s)

1. Handle small parts with care
2. Follow safety precautions.

VI Relevant Theoretical Background.

A photocopier, also called copier or copy machine, and formerly Xerox machine is a machine that makes copies of documents and other visual images onto paper or plastic film quickly and cheaply. Most modern photocopiers use a technology called xerography, a dry process that uses electrostatic charges on a light-sensitive photoreceptor to first attract and then transfer toner particles (a powder) onto paper in the form of an image. The toner is then fused onto the paper using heat, pressure, or a combination of both. Thus photocopiers work on the principle that 'opposites attract'. Toner is a powder that is used to create the printed text and images on paper. The powder is negatively charged, and so it is attracted to something positive - the paper. Copiers can also use other technologies, such as inkjet, but xerography is standard for office copying.

VII Actual Circuit diagram used in a laboratory with related equipment rating.

a. Suggested Kit / Circuit Diagram:

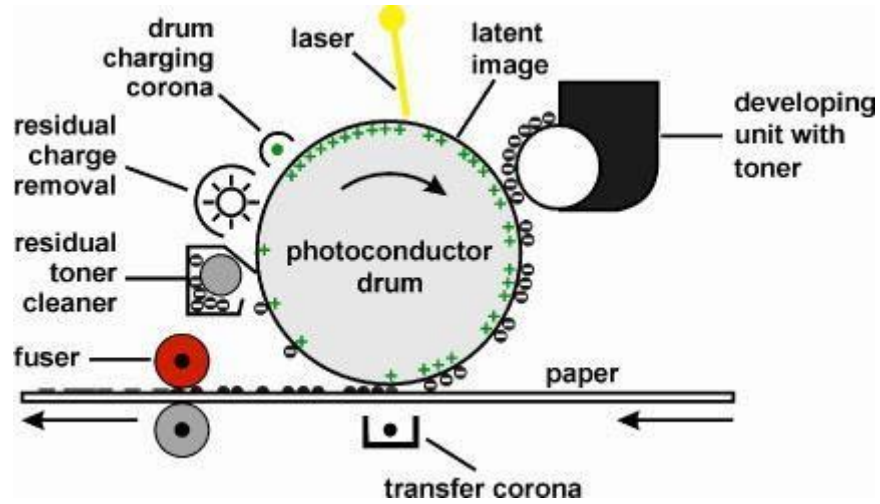

Figure 11.1: Internal components of Photocopier machine

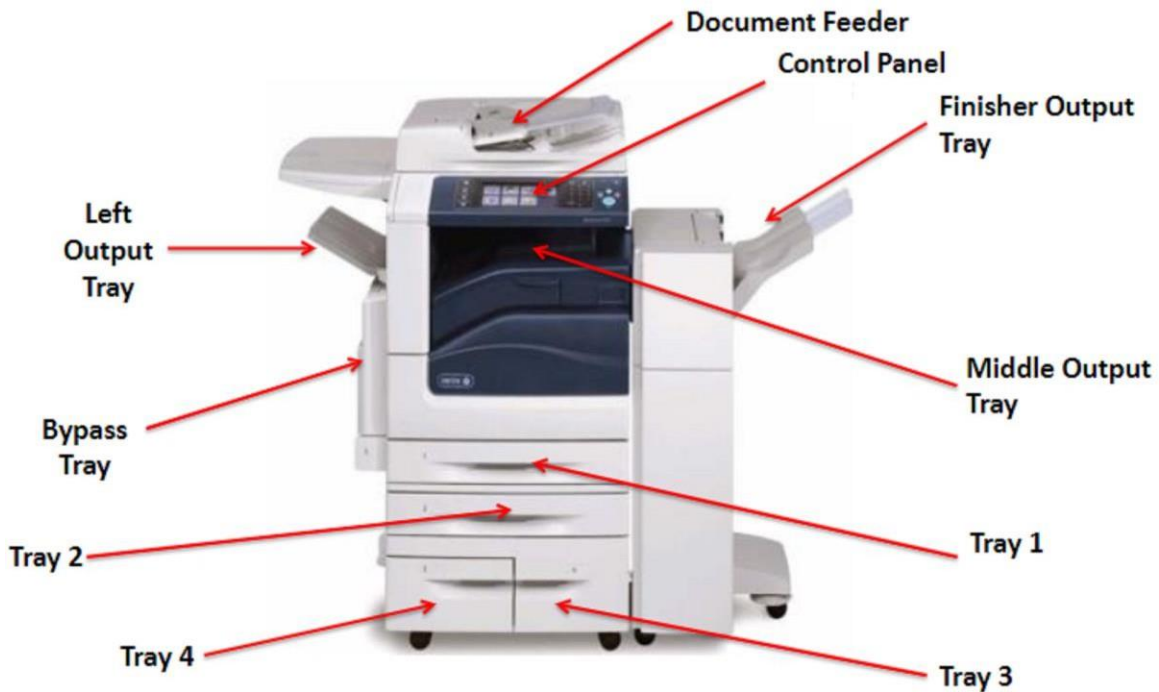

Figure 11.2: Photocopier Machine

b. Actual circuit diagram/Kit used in the laboratory:**VIII Required Resources/apparatus/equipment with specifications:**

Sr. No.	Instruments/Components	Specifications	Quantity
1	Photocopier machine	Print speed 20 ppm,600 dpi x 600 dpi resolution	01
2	Screw drivers	Standard set	01
3	Pliers	Standard set	01
4	Tweezers	Standard set	01
5	Compressed air can	Appearing as gas at room temperature, pressure 6.8 Bar at 25 ⁰ C	01
6	Cleaning cloths	-	01
7	Isopropyl Alcohol	Quality Level. 200, impurities. ≤0.5%	01
8	Protective gloves	cotton knitted material with Nitrile material coating on palm and fingers.	01 pair

IX Precautions to be followed (Safety instructions / Rules / Standards)

- 1.Ensure the photocopier machine is turned off and unplugged from the power source.
- 2.Use an anti-static wrist strap to avoid damaging sensitive electronic components.
- 3.Keep the work area clean and organized to avoid losing small parts.

X Procedure

Test the wires/cables/Electronic Components used for connections properly. If they are faulty then keep it in the proper E-waste bin.

A Disassembly

1. Open and carefully remove the paper tray.
2. Locate and remove screws or clips holding the covers or panels that conceal the paper feed mechanism.
3. Carefully remove the covers to expose the paper feed rollers, gears, and other components.
4. Gently pull out the feed rollers. Take note of their position and orientation.
5. Inspect and disconnect other components such as gears, sensors, and belts. Take pictures and notes on their placement.
6. Use compressed air and cleaning cloths to remove dust and debris from all parts.

B Reassembly

1. Place the feed rollers back into their original positions, ensuring they are properly aligned and secured.
2. Replace gears, sensors, and other parts in their original locations, referring to your notes and. Photos.
3. Reattach the covers or panels, securing them with the appropriate screws or clips.
4. Place the paper tray back into the machine.
5. Plug in and turn on the photocopier. Test the machine.

XI Required Resources

Sr. No.	Instruments/Components	Specifications	Quantity

XIV Result(s):

.....
.....

XV Interpretation of Results:

.....
.....

XVI Conclusions and Recommendations:

.....
.....
.....

XVII Practical Related Questions:

Note: Below given are few sample questions. Teachers must design such questions to ensure achievement of identified CO.

- 1 State the model details of the photocopier machine.
- 2 State the components of the paper feed mechanism.
- 3 What tools are needed for the photocopier machine dismantling and assembling process?
- 4 State the features of a photocopier machine.

[Space for Answers]

.....
.....
.....
.....
.....
.....
.....
.....
.....
.....
.....
.....
.....
.....
.....
.....
.....
.....
.....
.....

XVIII References/Suggestions for further reading: include websites/links/Virtual lab Link

- 1 <https://images.app.goo.gl/sA67a2bZ5cJAErwv9>
- 2 <https://images.app.goo.gl/33Vv2vMMPQ6MutXA9>

XIX Assessment Scheme

Performance Indicators		Weightage
Process Related (15 Marks)		60%
01	Identification of different blocks on trainer kit	10%
02	Connection made on kit	20%
03	Observation and Measurement taken	20%
04	Handling of equipment and Working in team	10%
Product Related (10 Marks)		40%
05	Interpretation of Results	15%
06	Conclusions	05%
07	Practical Related Questions	15%
08	Submission of Journal in time	05%
Total (25 Marks)		100 %

Marks Obtained			Dated Signature of Teacher
Process Related (15)	Product Related (10)	Total (25)	

Practical No. 12: Identification of front panel controls of microwave oven

I Practical Significance:

Identifying and understanding the front panel controls of a microwave oven significantly enhance practical usage, ensuring that the appliance is used safely, efficiently, and effectively. This knowledge is essential for optimizing cooking results, preventing accidents and maintaining the appliance in good working order.

II Industry / Employer Expected outcome(s)

The aim of this practical is to attend the following industry/employer expected outcome through various teaching learning experiences.

Maintain various consumer electronic appliances/equipment.

III Course Level Learning outcome(s)

- Troubleshoot various consumer electronic appliances.

IV Laboratory Learning outcome(s)

- Identify and test various front panel controls of the microwave oven.

V Relevant Affective Domain related outcome(s)

1. Handle equipment carefully.
2. Follow safety precautions.

VI Relevant Theoretical Background.

A microwave oven or simply microwave is an electric oven that heats and cooks food by exposing it to electromagnetic radiation in the microwave frequency range. This induces polar molecules in the food to rotate and produce thermal energy in a process known as dielectric heating. Microwave ovens heat foods quickly and efficiently because excitation is fairly uniform in the outer 25–38 mm (1–1.5 inches) of a homogeneous, high-water-content food item.

Modern microwave ovens use either an analog dial-type timer or a digital control panel for operation. Few of the front panel controls are:

Power/Start Button: Initiates the cooking process.

Number Keypad: Used to enter cooking time, power level, or other numeric inputs.

Weight Defrost Button: Sets defrosting time based on the weight of the food.

Power Level Button: Adjusts the cooking power level (e.g., High, Medium, Low).

Stop/Cancel Button: Stops the cooking process or clears the current settings.

VII Actual Circuit diagram used in a laboratory with related equipment rating.
a. Suggested Kit / Circuit Diagram:



Figure 12.1: Front panel of microwave oven

b. Actual circuit diagram/Kit used in the laboratory:

VIII Required Resources/apparatus/equipment with specifications:

Sr. No.	Instruments/Components	Specifications	Quantity
01	Microwave Oven Trainer kit	A fully functional microwave oven with a front panel containing various controls (buttons, dials, touchpads).	01
02	User Manual	specific to the microwave oven model being tested, providing detailed instructions on the operation and functions of each control.	01

IX Precautions to be followed (Safety instructions / Rules / Standards)

1. Before beginning the experiment, make sure the microwave oven is unplugged to avoid any risk of electrical shock.
2. Do not touch the controls with wet hands to prevent electrical hazards and damage to the appliance.
3. Do not run the microwave for extended periods without food inside, as this can damage the appliance.

X Procedure:

Test the wires/cables/Electronic Components used for connections properly. If they are faulty then keep it in the proper E-waste bin.

Safety Check: Ensure the microwave oven is unplugged before starting the experiment to avoid any electrical hazards.

Initial Inspection: Visually inspect the front panel of the microwave oven. Note the layout and labels of the controls

Control Identification: Identify each button, dial, or touchpad on the front panel. Note the symbols, text, or icons associated with each control.

Function Testing (if the microwave can be plugged in safely): Plug in the microwave oven. Test each control by following the manufacturer's instructions. Observe the response of the microwave to each control input (e.g., the display changes, lights turn on, the turntable rotates).

Notes on Specific Controls

- **Power/Start Button:** This button often doubles as a quick start button when pressed multiple times in quick succession.
- **Stop/Cancel Button:** Important for halting the microwave immediately in case of an emergency.
- **Timer/Clock Button:** Can be confusing if the same button is used for both functions; read the manual for specific instructions.
- **Number Pad:** Typically used for setting the time in seconds or minutes, and sometimes for power levels.
- **Defrost Button:** Some models have automatic defrosting based on weight or type of food.

XI Required Resources

Sr. No.	Instruments/Components	Specifications	Quantity	Remarks

XII Actual procedure followed

.....

.....

.....

.....

.....

.....

XIII Observation table:

Sr. No.	Control Name	Type (Button /Dial/Touch pad)	Symbol/Text/ /Icon	Function Description
1	Power/Start			
2	Stop/Cancel			
3	Timer/Clock			
4	Number Pad			
5	Power level			
6	Defrost			
7	Turntable ON/OFF			
8	Door Release			

XVIII References/Suggestions for further reading: include websites/links/Virtual lab Link1 <https://images.app.goo.gl/LRpRkLPpTu9LxHRa6>2 <https://www.maytag.com/blog/kitchen/parts-of-a-microwave.html>**XIX Assessment Scheme**

Performance Indicators		Weightage
Process Related (15 Marks)		60%
01	Identification of different blocks on trainer kit	10%
02	Connection made on kit	20%
03	Observation and Measurement taken	20%
04	Handling of equipment and Working in team	10%
Product Related (10 Marks)		40%
05	Interpretation of Results	15%
06	Conclusions	05%
07	Practical Related Questions	15%
08	Submission of Journal in time	05%
Total (25 Marks)		100 %

Marks Obtained			Dated Signature of Teacher
Process Related (15)	Product Related (10)	Total (25)	

Practical No. 13: Fault analysis in microwave oven

I **Practical Significance:**

Fault analysis in microwave ovens holds significant practical importance, enhancing safety, performance, and longevity of the appliance. It contributes to cost savings, environmental conservation, and the development of technical skills. Regular and thorough fault analysis ensures that microwave ovens remain reliable, efficient, and safe for everyday use, benefiting both users and manufacturers.

II **Industry / Employer Expected outcome(s):**

The aim of this practical is to attend the following industry/employer expected outcome through various teaching learning experiences.

Maintain various consumer electronic appliances/equipment.

III **Course Level Learning outcome(s)**

- Troubleshoot various consumer electronic appliances.

IV **Laboratory Learning outcome(s)**

- Detect and rectify faults in microwave oven - a) Oven not starting b) Oven not heating c) Error display.

V **Relevant Affective Domain related outcome(s)**

1. Handle equipment carefully.
2. Follow safety precautions.

Relevant Theoretical Background.

Microwave ovens use electromagnetic waves, typically at a frequency of 2.45 GHz, to heat food. These waves are absorbed by water, fats, and sugars, causing them to vibrate and produce heat. It consists of -

Magnetron: The core component that generates microwaves. It converts electrical energy into microwave radiation.

Waveguide: A component that directs microwaves from the magnetron to the cooking chamber.

Turntable and Stirrer: Ensure even distribution of microwaves for uniform cooking.

Cooling fan.: The cooling fan keeps the microwave from overheating. The cooling fan automatically comes on during operation to cool the microwave oven.

Cooking cavity.: The cooking cavity is the inside compartment of your microwave where you cook, reheat, brown, or defrost your food.

Control Panel: The control panel allows the user to choose settings and determine what they want the microwave to do.

VII Actual Circuit diagram used in a laboratory with related equipment rating.

a. Suggested Kit / Circuit Diagram:

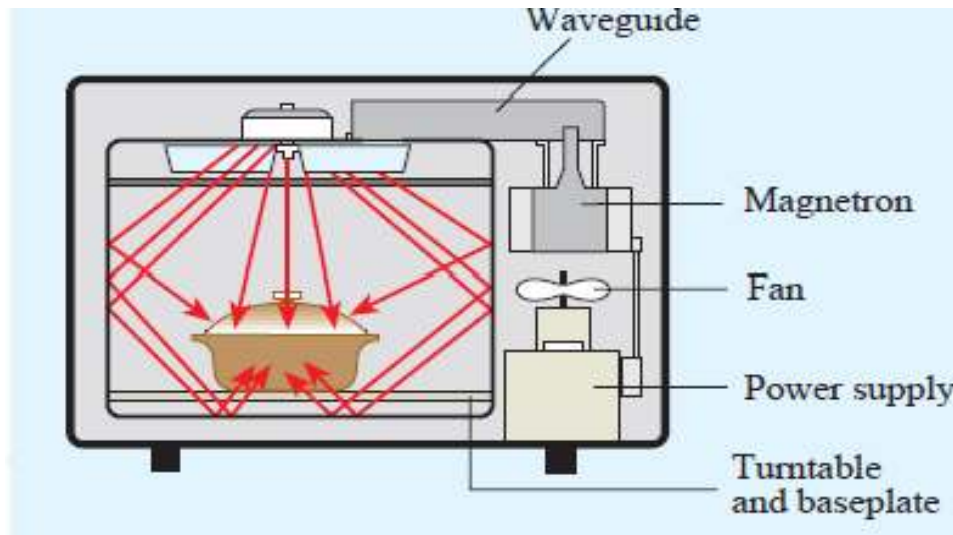

Figure13.1: Parts of Microwave oven

b. Actual circuit diagram/Kit used in the laboratory:

VIII Required Resources/apparatus/equipment with specifications:

Sr. No.	Instruments/Components	Specifications	Quantity
1	Microwave Oven Trainer kit	A fully functional microwave oven with a front panel containing various controls (buttons, dials, touchpads).	01
2	User Manual	Specific to the microwave oven model being tested, providing detailed instructions on the operation and functions of each control.	01
3	Multi-meter	Digital-DC/AC-20mV to 20 V	01
4	Screwdrivers	-	01/2
5	Pliers	-	01/2

IX Precautions to be followed (Safety instructions / Rules / Standards)

- 1 Ensure the microwave oven is unplugged from the power source before beginning any fault analysis.
- 2 Avoid touching the high-voltage parts of the microwave, such as the magnetron and the high-voltage transformer, directly.
- 3 When testing the microwave's operation, place a microwave-safe container with water inside to absorb the microwaves and prevent damage to the magnetron.

X Procedure:

Test the wires/cables/Electronic Components used for connections properly. If they are faulty then keep it in the proper E-waste bin.

1. Ensure the microwave is disconnected from the power source.
2. Using a resistor, safely discharge any capacitors to prevent electrical shocks. Connect the resistor across the terminals of the capacitor and hold it in place until it is fully discharged.

Fault Analysis and rectification:**a) Oven not starting:**

- 1 Check if the microwave oven is plugged in properly and that the power outlet is working.
- 2 Make sure the door of the microwave oven is closed securely. Some models have safety mechanisms that prevent the oven from starting if the door is not closed properly. Test fuse with a multi-meter.
- 3 Examine the control panel for any error codes or indicators that might suggest a specific issue.
- 4 If there are no visible issues, try resetting the microwave oven by unplugging it for a few minutes and then plugging it back in.

b) Oven not heating:

- 1 Check if the microwave oven is plugged in properly and that the power outlet is working.
- 2 Make sure the door of the microwave oven is closed securely.
- 3 Try setting the microwave oven to a different power level and heating time to see if it responds.
- 4 If the oven still doesn't heat, there might be an issue with the magnetron, capacitor, diode, or other heating components. Check each component using multi-meter and replace the faulty component

c) Error display:

- 1 Note down the error code displayed on the control panel.
- 2 Refer to the user manual for your microwave oven to interpret the error code. It may provide specific instructions on how to troubleshoot or resolve the issue.
- 3 **Check Control Board:** Look for burnt components or damaged traces on the control board. Repair or replace as necessary.

XI Required Resources

Sr. No.	Instruments/Components	Specifications	Quantity

XII Actual procedure followed

.....

.....

.....

.....

.....

.....

.....

.....

.....

.....

.....

XIII Observation table:

Sr. No.	Fault Type	Symptoms	Possible Causes	Observations
01	Oven not starting	No light inside	No sound from the oven	
02	Oven not heating	Light is on	Timer works but food remains cold	
03	Error display	Specific error code displayed	Oven beeps repeatedly	

XIV Result(s):

.....

XV Interpretation of Results:

Always _____ (plug/unplug) the microwave before performing any inspections or repairs.

XVI Conclusions and Recommendations:

.....

XVII Practical Related Questions:

Note: Below given are few sample questions. Teachers must design such questions to ensure achievement of identified CO.

1. What are the common signs that indicate a microwave oven is faulty?
2. What is the role of the door switch in the operation of a microwave oven?
3. How do you check the fuse in a microwave oven, and what tools are required for this test?
4. List the most common tools used for fault analysis in a microwave oven.

[Space for Answers]

.....

XVIII References/Suggestions for further reading: include websites/links/Virtual lab Link

1 <https://www.maytag.com/blog/kitchen/parts-of-a-microwave.html>

2 https://youtu.be/b7H1AOJpOxc?si=-tO_oMqejhs-A0x

XIX Assessment Scheme

Performance Indicators		Weightage
Process Related (15 Marks)		60%
01	Identification of different blocks on trainer kit	10%
02	Connection made on kit	20%
03	Observation and Measurement taken	20%
04	Handling of equipment and Working in team	10%
Product Related (10 Marks)		40%
05	Interpretation of Results	15%
06	Conclusions	05%
07	Practical Related Questions	15%
08	Submission of Journal in time	05%
Total (25 Marks)		100 %

Marks Obtained			Dated Signature of Teacher
Process Related (15)	Product Related (10)	Total (25)	

Practical No. 14: Performance of washing Machine

I Practical Significance:

Evaluating and understanding the performance of washing machines is crucial for continuous improvement, user satisfaction, and environmental sustainability. Analyzing water consumption can help in designing more water-efficient washing cycles, reducing waste and conserving water resources. Optimizing cycle durations can help in providing quicker washing options, saving time for users. Understanding the performance and stress on different components can lead to extending the machine's lifespan.

II Industry / Employer Expected outcome(s)

The aim of this practical is to attend the following industry/employer expected outcome through various teaching learning experiences.

Maintain various consumer electronic appliances/equipment.

III Course Level Learning outcome(s)

- Troubleshoot various consumer electronic appliances.

IV Laboratory Learning outcome(s)

- Set the time duration of different wash cycles for a given washing machine.

V Relevant Affective Domain related outcome(s)

1. Handle the equipment carefully
2. Follow all safety precautions

VI Relevant Theoretical Background.

A washing machine is an electrical machine consisting of different types of electric motors, switches, times, buzzers, etc. • There are different types of washing machines from different manufacturers available in the market, but all the washing machines work almost in the same principle.

At various stages of the washing cycle the drum is required to rotate at different speeds. • These include: a low speed of about 30 revolutions per minute (rpm) while clothes are washed: an intermediate speed of about 90 rpm while the water is pumped out and a high speed of either 500 or 1000 rpm to spin dry the clothes.

VII Actual Circuit diagram used in a laboratory with related equipment rating.

a. Suggested kit/equipment

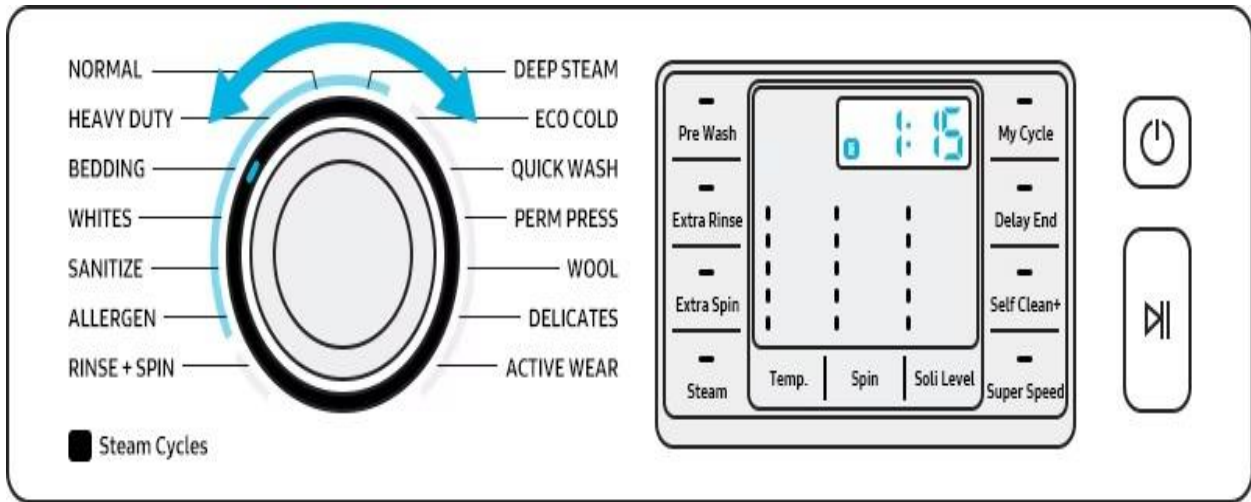

Figure 14.1: Front panel of washing machine

b Actual kit/equipment used in laboratory

VIII Required Resources/apparatus/equipment with specifications:

Sr. No.	Instruments/Components	Specifications	Quantity
1	Washing machine trainer kit	Single phase ,50 Hz,230 V AC, Semi -automatic type	01
2	User manual	As per the washing machine model	01

IX Precautions to be followed (Safety instructions / Rules / Standards)

1. Ensure the washing machine is properly grounded to avoid electrical shocks.
2. Do not touch electrical components with wet hands.
3. Keep the area around the washing machine dry to prevent slipping and electrical hazards.

X Procedure:

1. Test the wires/cables/Electronic Components used for connections properly. If they are faulty then keep it in the proper E-waste bin.
2. Select Initial Cycle Settings.
3. Run Control Tests for:
 - i. Water inlet sensor
 - ii. Spin/wash motor
 - iii. Timer
4. Modify the duration of each wash cycle incrementally (e.g., by 5-minute intervals).
5. Record the observations for each parameter.

XI Required Resources

Sr. No.	Instruments/Components	Specifications	Quantity

XII Actual procedure followed

.....

.....

.....

.....

XIII Observation table:

Sr. No.	Parameters to be observed	Observations
1	Water inlet sensor	
2	Whether Motor for spin/wash starts	
3	Timer set for various time period a.10 min b.15 min c 20 min	

XIV Result(s):

.....

XV Interpretation of Results:

.....

XVI Conclusions and Recommendations:

.....

XVII Practical Related Questions:

Note: Below given are few sample questions. Teachers must design such questions to ensure achievement of identified CO.

- 1 State the types of washing machines.
- 2 Which are the different motors used in washing machines?
- 3 State the different wash cycles?
- 4 Write the function of any four controls available on the front panel of washing machine.

[Space for Answers]

.....

XVIII References/Suggestions for further reading: include websites/links/Virtual lab Link

- 1 <https://da-iitb.vlabs.ac.in/exp/washin-machine-control/theory.html>
- 2 <https://images.app.goo.gl/fdSjgUyHgMpB3ymdA>
- 3 <https://da-iitb.vlabs.ac.in/exp/washin-machine-control/procedure.html>

XIX Assessment Scheme

Performance Indicators		Weightage
Process Related (15 Marks)		60%
01	Identification of different blocks on trainer kit	10%
02	Connection made on kit	20%
03	Observation and Measurement taken	20%
04	Handling of equipment and Working in team	10%
Product Related (10 Marks)		40%
05	Interpretation of Results	15%
06	Conclusions	05%
07	Practical Related Questions	15%
08	Submission of Journal in time	05%
Total (25 Marks)		100 %

Marks Obtained			Dated Signature of Teacher
Process Related (15)	Product Related (10)	Total (25)	

Practical No. 15: Sketch the wiring diagram of washing machine

I Practical Significance:

Understanding and creating a wiring diagram for a washing machine helps in diagnosing and repairing electrical issues within the washing machine. Also it ensures that all components are correctly connected, reducing the risk of electrical hazards.

II Industry / Employer Expected outcome(s):

The aim of this practical is to attend the following industry/employer expected outcome through various teaching learning experiences.

Maintain various consumer electronic appliances/equipment.

III Course Level Learning outcome(s)

- Troubleshoot various consumer electronic appliances.

IV Laboratory Learning outcome(s)

- Sketch the wiring diagram of the washing machine and locate its main components.

V Relevant Affective Domain related outcome(s)

1. Handle equipment carefully.
2. Follow safety precautions.

VI Relevant Theoretical Background.

A washing machine is one that washes and dries the clothes. A washing machine is an electrical machine consisting of different types of electric motors, switches, timers, buzzers, etc.

Internal Parts of the Washing Machine

Spin Motor:

Spin Motor is also known as a dryer motor. It is used to dry the clothes. A spin motor is a single- phase induction motor. It has two windings Starting winding and running winding. It required a capacitor to start. Generally, a capacitor is used with this spin motor. Also, a capacitor is connected to the spin motor. The spin motor is low power rated than the wash motor.

Wash Motor:

A Wash motor is used to wash the cloth. It is more powerful than the spin motor because it has to make the movement of wet clothes with water. The wash motor is also a single-phase induction motor, it also has two windings - running winding and starting winding. Here also, a capacitor is required for its operation. The wash motor is subjected to rotate in both directions and it is done by the wash timer. The speed and torque of the Wash motor is more than the spin motor.

Spin Timer:

Spin Timer is used to operate the Spin motor. A spin timer is a two-terminal device, it is to be connected with the spin motor and the power supply. Spin motor and Spin timer are used in both semiautomatic and automatic washing machines.

Wash Timer:

The Wash Timer is used to operate the wash motor. The function of the wash timer is to rotate the wash motor with a preset time, change the direction of the rotation of the motor, and turn on the buzzer or alarm when washing is completed. There are different types of wash timers are available such as three-terminal wash timers, four-terminal wash timers, and six terminal wash timers.

Door Switch:

The door switch provides the function to operate the washing machine when the door is only in closed condition. You can see the door switch is connected in series with the spin motor so, until the door is closed, the spin motor will not work.

VII Actual Circuit diagram used in a laboratory with related equipment rating.**a. Suggested Kit / Circuit Diagram:**

Figure 15.1: Washing machine wiring diagram

b. Actual kit/circuit diagram:**VIII Required Resources/apparatus/equipment with specifications:**

Sr. No.	Instruments/Components	Specifications	Quantity
1	Washing machine trainer kit	Single phase ,50 Hz,230 V AC, Semi -automatic type	01
2	Service manual for the washing machine	-	01
3	Paper/pencil/Colored pencils/markers	-	01

IX Precautions to be followed (Safety instructions / Rules / Standards)

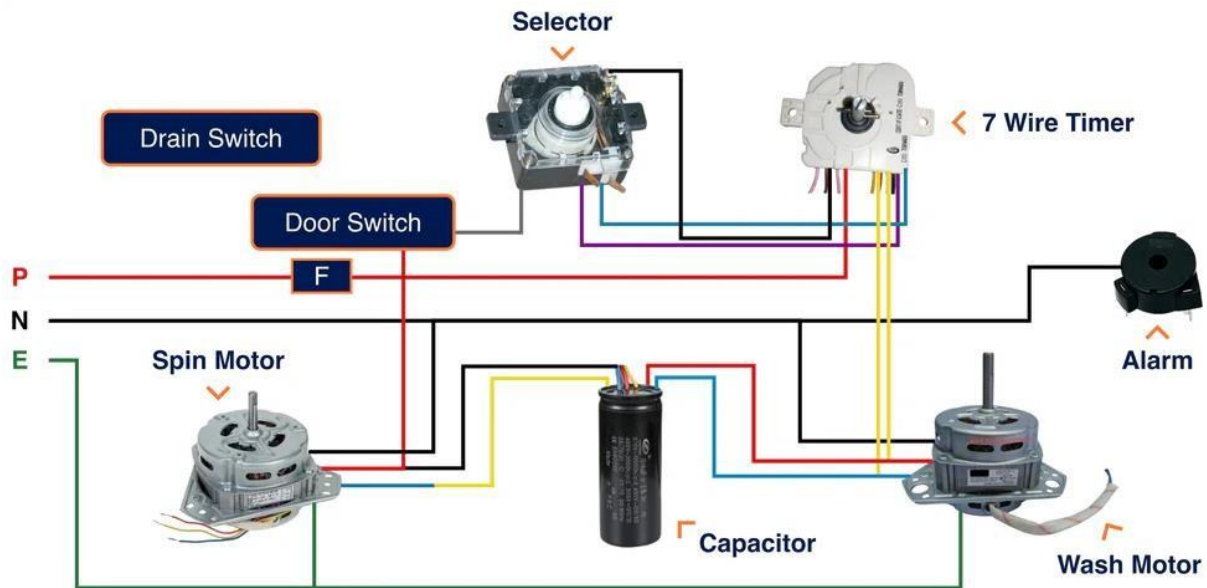
1. Ensure the power is turned off before starting any wiring or adjustments.
2. Ensure that all electrical components are kept dry.
3. Inspect all equipment and wiring for damage or defects before use.
4. Conduct the experiment in a well-ventilated area to avoid the buildup of fumes or gases.

X Procedure:

1. Test the wires/cables/Electronic Components used for connections properly. If they are faulty then keep it in the proper E-waste bin.
2. Carefully open and inspect the washing machine.
3. Locate each of the main components listed.
4. Sketch the rough outline of the washing machine's components on paper.
5. Identify the locations of major components such as the control board, motors, sensors, and valves.
6. Draw lines to represent the electrical connections between the components.
7. Use symbols to denote different components (refer to electrical standards for symbols).

.....
.....
.....
.....

XIII Observation table:

Sr. No.	Component	Location
01	Power Cord	
02	Main Power Switch	
03	Main Control Board	
04	User Interface Panel	
05	Drive Motor	
06	Pump Motor	
07	Door Lock Mechanism	
08	Drain Pump	

XIV Result(s):

.....
.....

XV Interpretation of Results:

.....
.....

XVI Conclusions and Recommendations:

.....
.....

XVIII References/Suggestions for further reading: include websites/links/Virtual lab Link

1 https://www.youtube.com/watch?v=7Rl5OTx_u80

2 https://youtu.be/PD-xs8vTxI0?si=l2RDFhvrhLi_ElNV

XIX Assessment Scheme

Performance Indicators		Weightage
Process Related (15 Marks)		60%
01	Identification of different blocks on trainer kit	10%
02	Connection made on kit	20%
03	Observation and Measurement taken	20%
04	Handling of equipment and Working in team	10%
Product Related (10 Marks)		40%
05	Interpretation of Results	15%
06	Conclusions	05%
07	Practical Related Questions	15%
08	Submission of Journal in time	05%
Total (25 Marks)		100 %

Marks Obtained			Dated Signature of Teacher
Process Related (15)	Product Related (10)	Total (25)	

Practical No. 16: Fault analysis of washing machine

I Practical Significance:

Fault analysis in washing machines is a critical process with several practical applications and benefits. Understanding the practical significance can help in various areas, including maintenance, repair, design improvements, and safety enhancements.

II Industry / Employer Expected outcome(s):

The aim of this practical is to attend the following industry/employer expected outcome through various teaching learning experiences.

Maintain various consumer electronic appliances/equipment.

III Course Level Learning outcome(s)

- Troubleshoot various consumer electronic appliances.

IV Laboratory Learning outcome(s)

- Troubleshooting of washing machine - a) Excessive noise during operation b) Door lock problem.

V Relevant Affective Domain related outcome(s)

1. Handle equipment carefully.
2. Follow safety precautions.

VI Relevant Theoretical Background.

When troubleshooting washing machines, understanding the underlying principles and common issues can help diagnose and resolve problems effectively. Here, we focus on two specific problems: excessive noise during operation and door lock problems

A. Excessive Noise During Operation

Excessive noise in washing machines can stem from various sources, including mechanical, electrical, or operational issues in various components like motors, pump, drive belt, drum and tub.

B. Door Lock Problems

A malfunctioning door lock can prevent the washing machine from starting or completing a cycle. Door lock mechanism consists of-

Latch Mechanism: The door latch physically secures the door. If it is misaligned or broken, the door may not lock properly.

Locking Mechanism: Some washing machines use a mechanical lock that engages when the door is closed.

VII Actual Circuit diagram used in a laboratory with related equipment rating.

a. Suggested Kit/circuit diagram

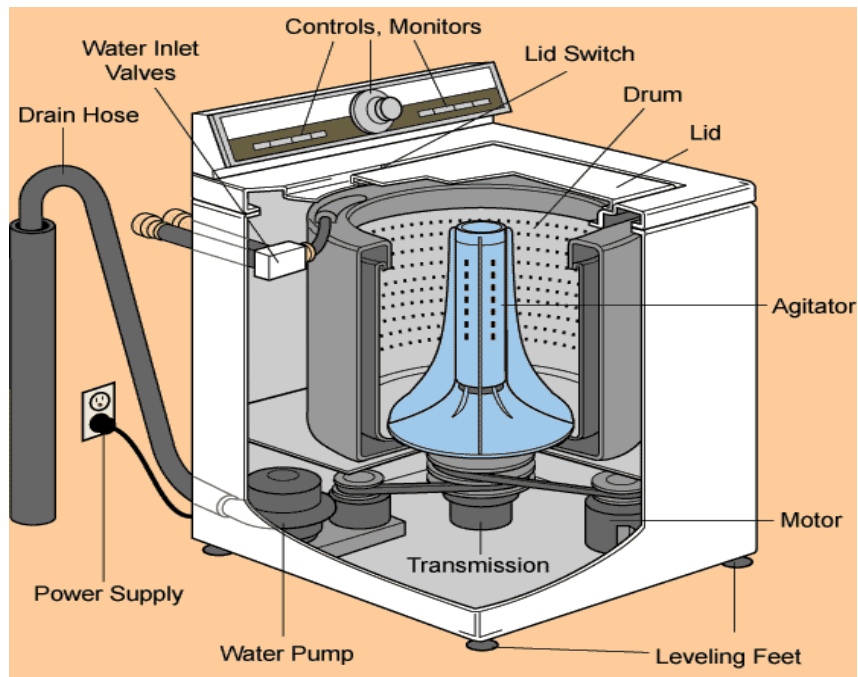

Figure 16.1: Parts of washing machine

b. Actual setup diagram

VIII Required Resources/apparatus/equipment with specifications:

Sr. No.	Instruments/Components	Specifications	Quantity
1	Washing machine trainer kit	Semi-automatic functional washing machine	01
2	User manual	specific to the microwave oven model being tested, providing detailed instructions on the operation and functions of each control.	01
3	Multi-meter	Digital-DC/AC-20mV to 20 V	01
4	Screwdrivers	Standard set	01
5	Pliers	Standard set	01
6	Gloves	Rubber Gloves	01 pair
7	Lubricant	-	01
8	Leveling tool	With anti-Vibration Pads for Washing Machine - 4 Pads with Tank Tread Grip + Level - Washer Dryer Pedestals	01

IX Precautions to be followed (Safety instructions / Rules / Standards)

- 1 Ensure the washing machine is unplugged from the power source before beginning any fault analysis.
- 2 Avoid touching the high-voltage parts of the washing machine.

X Procedure:

- 1 Test the wires/cables/Electronic Components used for connections properly. If they are faulty then keep it in the proper E-waste bin.

Excessive Noise During Operation:

- 1 Unplug the washing machine from the power source.
- 2 Open the washing machine door and inspect the drum for any foreign objects that may be causing noise.
- 3 Check for any obvious loose parts inside the drum.
- 4 Using a leveling tool ensure the washing machine is evenly placed on the floor.
- 5 Adjust the machine's feet if necessary to make sure it is level.
- 6 Inspect Bearings and Seals by removing the washing machine panels using Screwdrivers
- 7 Check the drum bearings for wear and tear.
- 8 If bearings are worn out, use a bearing puller to remove them and replace them with new ones.
- 9 Inspect the seals and replace them if they are damaged.
- 10 Locate the shock absorbers and springs inside the machine.
- 11 Inspect them for wear or damage.
- 12 Replace any worn or damaged shock absorbers or springs with new ones.
- 13 Locate the drive belt connecting the motor to the drum.
- 14 Check the belt for wear, cracks, or looseness.
- 15 Replace the belt if it is worn or damaged.

- 16 Apply lubricant to moving parts such as bearings and pulleys to ensure smooth operation.
- 17 Plug in the washing machine and run a test cycle to check for noise reduction.

B. Door Lock Problem

1. Unplug the washing machine from the power source.
2. Inspect the door latch and ensure it is properly aligned. Check for any visible damage to the latch mechanism.
3. Test the Door Lock Switch by removing the washing machine’s control panel .
4. Locate the door lock switch.
5. Use a multi-meter to test the continuity of the switch. If the switch does not show continuity when the door is closed, it may be faulty.
6. Replace the door lock switch if it is faulty.
7. Inspect the Solenoid or Actuator.
8. Check for any visible damage or wear.
9. Test the solenoid with a multi-meter to ensure it is receiving power and functioning correctly.
10. Replace the solenoid or actuator if it is malfunctioning.
11. Locate the control board within the washing machine.
12. Inspect the board for any signs of damage, such as burnt components or broken traces.
13. Replace the control board if it is identified as the source of the problem.

C. Test Run: Reassemble the washing machine panels and control panel.

- 1 Plug in the washing machine and close the door.
- 2 Run a test cycle to ensure the door locks properly and the machine operates as expected.
- 3 Verify that the door remains locked during operation and unlocks at the end of the cycle.

XI Required Resources

Sr. No.	Instruments/Components	Specifications	Quantity

XII Actual procedure followed

.....

XIII Observation table:**A. Excessive Noise During Operation:**

Sr. No.	Step	Observation	Action taken
01	Initial Inspection	Presence of foreign objects in drum?	
		Any loose parts inside the drum?	
02	Level the Machine/ Mounting of machine	Washing machine level wrt floor?	
03	Inspect Bearings and Seals	Bearings worn out?	
04	Check Shock Absorbers/ Spring	Shock absorbers/springs damaged?	
05	Examine the Drive Belt	Drive belt worn or damaged?	
06	Lubricate Moving parts	Moving parts properly lubricated?	

B. Door Lock Problem

Sr. No.	Step	Observation	Action taken
01	Initial Inspection	Door latch slightly mismatched	
		No visible damage	
02	Test the Door Lock switch	Switch showed no continuity	
03	Inspect the solenoid or Actuator	Solenoid functioning correctly	
04	Examine the Control Board	Control board appeared in good condition	

XIV Result(s):

.....

XV Interpretation of Results:

.....

XVI Conclusions and Recommendations:

.....

XVII Practical Related Questions:

Note: Below given are few sample questions. Teachers must design such questions to ensure achievement of identified CO.

- 1 State the components which cause noise during washing machine operation.
- 2 List the buttons/knobs available on the washing machine control panel.
- 3 What are the possible causes for excessive noise in the washing machine?
- 4 Why is lubrication important in the maintenance of a washing machine?

[Space for Answers]

.....

XVIII References/Suggestions for further reading: include websites/links/Virtual lab Link1 <https://images.app.goo.gl/aJSpB4CBVzyvfGRcA>2 <https://onsitego.com/blog/fixing-loud-washing-machine/>**XIX Assessment Scheme**

Performance Indicators		Weightage
Process Related (15 Marks)		60%
01	Identification of different blocks on trainer kit	10%
02	Connection made on kit	20%
03	Observation and Measurement taken	20%
04	Handling of equipment and Working in team	10%
Product Related (10 Marks)		40%
05	Interpretation of Results	15%
06	Conclusions	05%
07	Practical Related Questions	15%
08	Submission of Journal in time	05%
Total (25 Marks)		100 %

Marks Obtained			Dated Signature of Teacher
Process Related (15)	Product Related (10)	Total (25)	

Practical No. 17: Use the various functions of Camcorder

I Practical Significance:

Testing iris (aperture) and shutter speed is crucial for understanding how well the camcorder can handle different lighting conditions. Proper control over these settings ensures that footage is neither overexposed nor underexposed. Computer interface ensures smooth and efficient transfer of video files to computers for editing and storage. Different formats offer various levels of quality and compression. Testing ensures that users can choose the best format for their needs, balancing quality with file size.

II Industry / Employer Expected outcome(s):

The aim of this practical is to attend the following industry/employer expected outcome through various teaching learning experiences.

Maintain various consumer electronic appliances/equipment.

III Course Level Learning outcome(s)

- Troubleshoot various consumer electronic appliances.

IV Laboratory Learning outcome(s)

- Test the various functions of Camcorder such as iris and shutter speed control, computer interface, recording rate and recording format.

V Relevant Affective Domain related outcome(s)

1. Handle the camcorder carefully.
2. Follow safety precautions while using the controls.

VI Relevant Theoretical Background:

A camcorder is a self-contained portable electronic device with video and recording as its primary function. The important functions/controls available on the camcorder are-

Iris (Aperture) Control: The iris, or aperture, controls the amount of light entering the camcorder lens. The aperture setting affects depth of field.

Shutter Speed Control: Shutter speed determines how long the camera's sensor is exposed to light. It is measured in fractions of a second (e.g., 1/60, 1/1000).n video recording, shutter speed is typically set to be double the frame rate to achieve natural motion blur and avoid strobing effects.

Computer Interface: Enables the camcorder to connect with a computer for data transfer and remote control.

Recording Rate (Frame Rate): Defines how many frames are captured per second.

Recording Format: Determines the file format and compression used to store the video.

VII Actual Circuit diagram used in a laboratory with related equipment rating.

a. Suggested kit/circuit diagram.

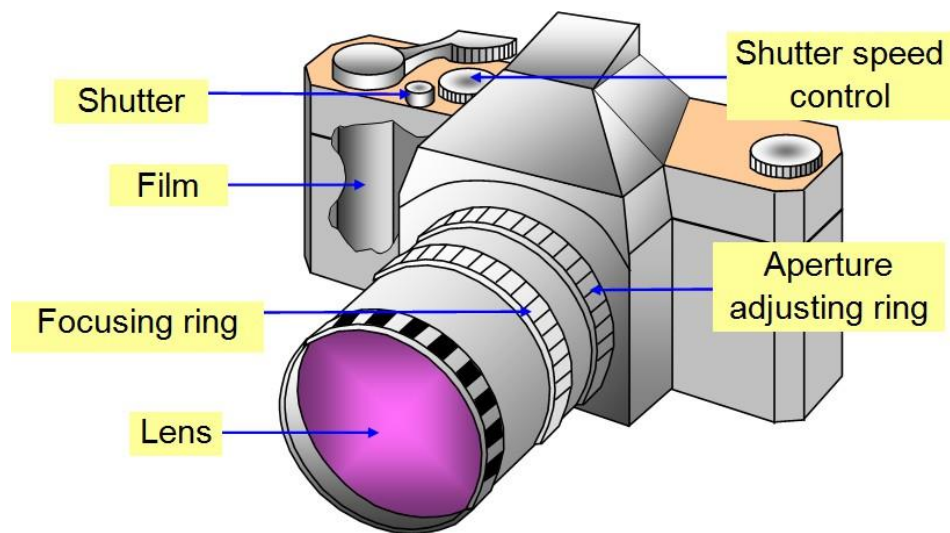

Figure 17.1 : Parts of a camcorder

b. Actual kit/circuit diagram .

VIII Required Resources/apparatus/equipment with specifications:

Sr. No.	Instruments/Components	Specifications	Quantity
1	Camcorder	Min.10 MP, Full manual control of aperture, shutter speed, focus and flash, Zoom lens, HD Video Recording capability	01
2	Computer	Any computer available in lab	01
3	USB/HDMI Cable:	-	01

IX Precautions to be followed (Safety instructions / Rules / Standards)

- 1 Camcorders are delicate instruments. Handle them carefully to avoid damage.
- 2 Ensure the camcorder is fully charged and has enough storage space before checking the Functions.
- 3 Avoid exposing the camcorder to extreme temperatures, moisture, or dust.

X Procedure:

Test the wires/cables/Electronic Components used for connections properly. If they are faulty then keep it in the proper E-waste bin.

PART 1

- 1 Charge the camcorder battery fully.
- 2 Insert the memory card.
- 3 Record a static scene for 1-2 minutes.
- 4 Observe and note the ease of use of basic controls.

PART 2**Controls/Functions**

1. **Iris (Aperture) Control:** Set the iris and check its function.
2. **Shutter Speed Control:** Record a short video (of 30 second) and test the shutter speed and variations in the recording.
3. **Computer Interface:** Connect the camcorder to the computer using the appropriate cable (USB, HDMI, etc.). Transfer recorded videos from the camcorder to the computer.
4. **Recording Rate:** Record a short video at different recording/frame rate and observe the function of recording rate.
5. **Recording Format:** Check the different available recording formats and observe the impact on video quality, size and compatibility with software.

XIV Result(s):
.....
.....

XV Interpretation of Results:
.....
.....

XVI Conclusions and Recommendations:
.....
.....

XVII Practical Related Questions:

Note: Below given are few sample questions. Teachers must design such questions to ensure achievement of identified CO.

- 1 What is the maximum and minimum aperture available on the camcorder?
- 2 What is the range of shutter speeds available on the camcorder?
- 3 How does the camcorder handle high frame rates in terms of battery consumption and heat generation?
- 4 What recording formats (e.g., AVCHD, MP4, MOV) are available on the camcorder?
- 5 How does changing the frame rate affect the smoothness of motion in the recorded video?

[Space for Answers]

.....
.....
.....
.....
.....
.....
.....
.....
.....
.....
.....
.....
.....
.....
.....
.....
.....
.....
.....
.....
.....

XVIII References/Suggestions for further reading: include websites/links/Virtual lab Link

1. <https://www.hitlabnz.org/index.php/virtual-labs/>
2. <https://iconiccamera.com/parts-of-a-video-camera-and-their-functions/>
3. <https://www.adorama.com/alc/9-online-camera-simulators-to-help-your-photography-skill/>

XIX Assessment Scheme

Performance Indicators		Weightage
Process Related (15 Marks)		60%
01	Identification of different blocks on trainer kit	10%
02	Connection made on kit	20%
03	Observation and Measurement taken	20%
04	Handling of equipment and Working in team	10%
Product Related (10 Marks)		40%
05	Interpretation of Results	15%
06	Conclusions	05%
07	Practical Related Questions	15%
08	Submission of Journal in time	05%
Total (25 Marks)		100 %

Marks Obtained			Dated Signature of Teacher
Process Related (15)	Product Related (10)	Total (25)	

Practical No. 18: Interfacing of scanner

I Practical Significance:

Interfacing a scanner with a computer involves ensuring that the scanner can communicate effectively with the computer for transferring scanned images and documents. Efficient interfacing allows for quick and seamless scanning of documents directly to the computer, reducing the time spent on manual data entry or transferring files via external storage devices.

II Industry / Employer Expected outcome(s)

The aim of this practical is to attend the following industry/employer expected outcome through various teaching learning experiences.

Maintain various consumer electronic appliances/equipment.

III Course Level Learning outcome(s)

- Troubleshoot various consumer electronic appliances.

IV Laboratory Learning outcome(s)

- Interface the scanner to the desktop computer and test its various controls.

V Relevant Affective Domain related outcome(s)

1. Handle the scanner carefully.
2. Follow safety precautions.

VI Relevant Theoretical Background.

A scanner is a device that captures images from photographic prints, posters, magazine pages and similar sources for computer editing and display. Scanners work by converting the image on the document into digital information that can be stored on a computer through optical character recognition (OCR). This process is done by a scanning head, which uses one or more sensors to capture the image as light or electrical charges.

The document scanner moves either the physical document or the scanning head, depending on the type of scanner. Then, the scanner processes the scanned image and produces a digital image that can be stored on a computer. Scanners usually attach to a computer system and come with scanning software applications that let you resize and otherwise modify a captured image. If a printer is hooked up to the computer, you could print a second hard copy of the scanned image and store it in digital format.

VII Actual Circuit diagram used in a laboratory with related equipment rating.

a. Suggested kit/circuit diagram.

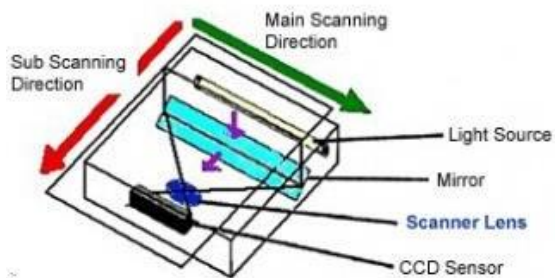

Figure 18.1: Scanner

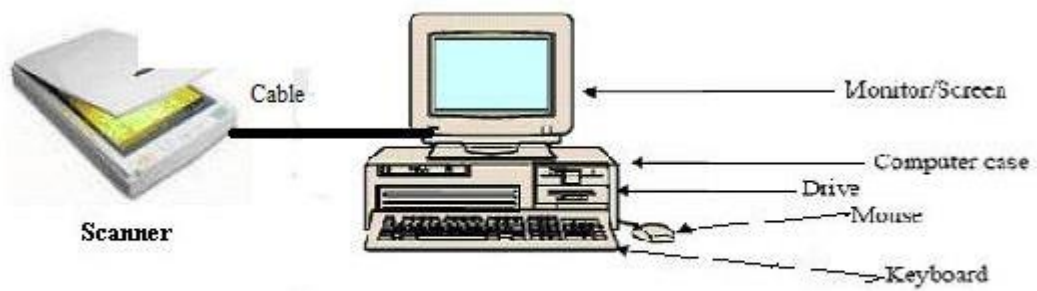

Figure 18.2: Scanner computer interfacing

b. Suggested kit/circuit diagram.

VIII Required Resources/apparatus/equipment with specifications:

Sr. No.	Instruments/Components	Specifications	Quantity
1	Scanner	Scanner-type-Flatbed color, Photoelectric device-Color CCD line sensor, effective pixels- 40,800 × 56,160 pixels at 4800 dpi, Output resolution-50 to 6400, 9600,	01
2	Computer system	A PC or laptop with the necessary ports (USB, Ethernet, etc.).	01
3	Cables and connectors	Appropriate cables for connecting the scanner to the computer (e.g., USB cables, Ethernet cables).	01
4	Software	VueScan,NAPS2	-
5	User manual	As per the scanner used	01

IX Precautions to be followed (Safety instructions / Rules / Standards)

- 1 Ensure the scanner is compatible with the operating system of the computer.
- 2 Place the scanner on a flat, stable surface to prevent vibrations that could affect scanning quality.
- 3 Determine the type of connection the scanner uses (USB, Wi-Fi, Ethernet).
- 4 Use good quality cables to avoid connection issues.

X Procedure:

1. Test the wires/cables/Electronic Components used for connections properly. If they are faulty then keep it in the proper E-waste bin.
2. Place the scanner in a stable, accessible location.
3. Connect the scanner to the computer using the appropriate cables.
4. Plug in the scanner and ensure it is powered on.
5. Install the drivers on the computer according to the provided instructions.
6. Open the scanning software and configure the basic settings (e.g., resolution, color mode, file format)
7. Perform initial test scans to verify the scanner is functioning correctly.
8. Check the scanned images for quality, resolution, and accuracy.
9. Adjust settings as needed based on test scan results.

XI Required Resources

Sr. No.	Instruments/Components	Specifications	Quantity

XII Actual procedure followed

.....

.....

.....

.....

.....

.....

.....

.....

.....

.....

.....

.....

.....

XIII Observation table:

Sr. No.	Control	Control Description/Function	Quality of Output
1	Driver Installation		Successful/Failed
2	Connection type		Stable/Unstable
3	Power ON		Ready/Not Ready
4	Software installation		Successful/Failed
5	Color Mode		Excellent/Good/Fair
6	Output quality		Excellent/Good/Fair

XIV Result(s):

.....
.....

XV Interpretation of Results:

.....
.....

XVI Conclusions and Recommendations:

.....
.....

XVII Practical Related Questions:

Note: Below given are few sample questions. Teachers must design such questions to ensure achievement of identified CO.

- 1 State the types of scanner.
- 2 How do you select and change the color mode (Color, Grayscale, Black & White)?
- 3 What are the available file formats for saving scanned documents?
- 4 How do you evaluate the quality of scanned documents?

[Space for Answers]

.....
.....
.....
.....
.....
.....
.....
.....
.....
.....
.....
.....
.....
.....
.....
.....
.....
.....
.....
.....
.....
.....

XVIII References/Suggestions for further reading: include websites/links/Virtual lab Link

- 1 <https://fab-coep.vlabs.ac.in/exp/3d-scanning/theory.html>
- 2 <https://youtu.be/5CP7Yh9fKbI?si=EtACjwygxXWqMDyT>

XIX Assessment Scheme

Performance Indicators		Weightage
Process Related (15 Marks)		60%
01	Identification of different blocks on trainer kit	10%
02	Connection made on kit	20%
03	Observation and Measurement taken	20%
04	Handling of equipment and Working in team	10%
Product Related (10 Marks)		40%
05	Interpretation of Results	15%
06	Conclusions	05%
07	Practical Related Questions	15%
08	Submission of Journal in time	05%
Total (25 Marks)		100 %

Marks Obtained			Dated Signature of Teacher
Process Related (15)	Product Related (10)	Total (25)	

Practical No. 19: Performance of given wearable antenna

I Practical Significance:

The practical significance of conducting an experiment on the performance of a wearable antenna lies in its ability to ensure that the antenna meets the demands of real-world applications. This encompasses reliability, safety, integration with devices, environmental resilience, power efficiency, commercial viability, and user experience. The insights gained from such experiments can lead to the development of more effective, reliable, and user-friendly wearable technology.

II Industry / Employer Expected outcome(s)

The aim of this practical is to attend the following industry/employer expected outcome through various teaching learning experiences.

Maintain various consumer electronic appliances/equipment.

III Course Level Learning outcome(s)

- Use various smart appliances.

IV Laboratory Learning outcome(s)

- Measure the signal strength of wearable antenna.

V Relevant Affective Domain related outcome(s)

1. Handle small parts with care
2. Follow safety precautions.

VI Relevant Theoretical Background.

A wearable antenna is designed to function while being worn. These antennas are commonly used in wearable wireless communication and bio-medical RF systems. Wearable antennas are used within the context of Wireless Body Area Networks (WBAN). Wearable Antennas are essentially any antenna that is specifically designed to function while being worn. Examples include smartwatches (which typically have integrated Bluetooth antennas), glasses (such as Google Glass which has WIFI and GPS antennas), GoPro action cameras (which have Wi-Fi & Bluetooth antennas, and are often strapped to a user to obtain their footage), and even the Nike+ Sensor (which communicates to a smartphone via Bluetooth, and is placed in a user's shoe). Wearable antennas are becoming increasingly common in consumer electronics.

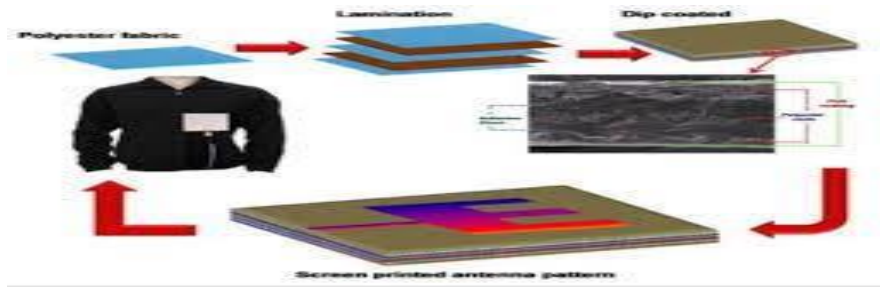

Figure 19.1: Wearable antenna

VII Actual Circuit diagram used in a laboratory with related equipment rating.
a. Suggested kit/circuit diagram.

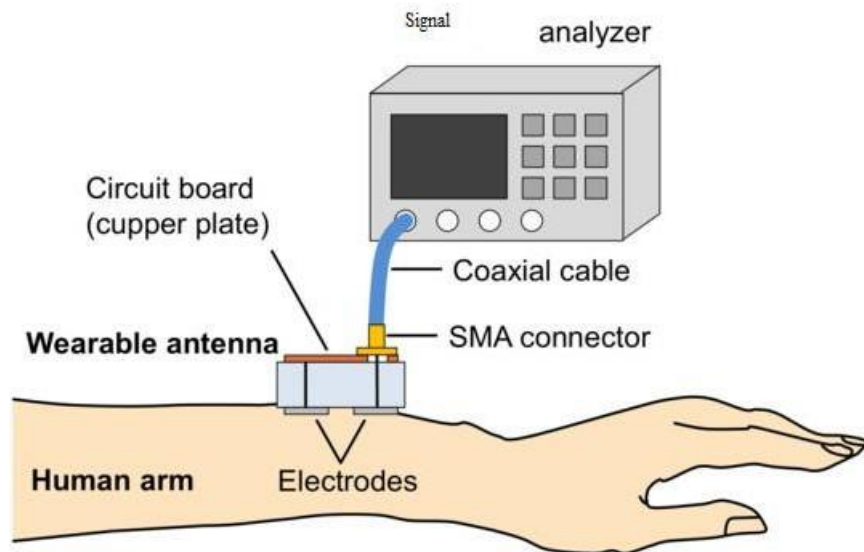

Figure 19.2: Set up to measure signal strength of wearable antenna

b. Actual kit/circuit diagram.

VIII Required Resources/apparatus/equipment with specifications:

Sr. No.	Instruments/Components	Specifications	Quantity
1	Smart Wristband	Bluetooth synchronization, low power accelerometer sensor, operating temp -10°C to 50° C ,system requirement –iOS 9.0 and above/Android 5.0 and above. (any other equivalent)	01
2	Signal Analyzer	Frequency Range: 125 MHz to 6 GHz with Pre-installed Baseband Generator	01
3	Signal Generator	0.1 Hz to 11 MHz, up/down range switchable in eight decade steps	01
4	Antenna testing software	CST Studio Suite, ANSYS HFSS OR FEKO	01
5	Cables and connectors	Appropriate cables for connecting the scanner to the computer	01
6	Computer	A PC or laptop with the necessary ports	01

IX Precautions to be followed (Safety instructions / Rules / Standards)

- 1 Before starting measurements, calibrate the signal generator to ensure the output power level is accurate and stable.
- 2 Maintain positioning of the wristwatch antenna during measurements. Use a mounting stand or fixture to ensure the wristwatch remains stationary.
- 3 Ensure all cables and connectors between the wristwatch and measurement equipment are securely connected to minimize signal loss.

X Procedure:

- 1 Test the wires/cables/Electronic Components used for connections properly. If they are faulty then keep it in the proper E-waste bin.
- 2 Connect the wristwatch (or any wearable antenna) to the signal generator via appropriate cables and connectors.
- 3 Connect the signal analyzer to receive signals from the wristwatch antenna.
- 4 Set the signal generator to transmit at the desired frequency (e.g., 2.4 GHz for Bluetooth)
- 5 Power on the wristwatch and allow it to stabilize for a few minutes
- 6 Activate the signal generator to transmit a continuous wave signal at the specified Frequency
- 7 Use the signal analyzer to measure and record the received signal strength
- 8 Record the signal strength readings in decibels (dB) or dBm (decibels relative to 1 mill watt).
- 9 Take measurements with the wristwatch antenna facing down.
- 10 Record the measured signal strength.

XIV Result(s):

.....
.....

XV Interpretation of Results:

.....
.....

XVI Conclusions and Recommendations:

.....
.....
.....

XVII Practical Related Questions:

Note: Below given are few sample questions. Teachers must design such questions to ensure achievement of identified CO.

1. State the different types of wearable antennas.
2. List any four applications of wearable antennas.
3. How does the signal strength vary when the wearable antenna is placed on different parts of the body (e.g., wrist, arm, chest)?
4. Which materials are used in fabricating wearable antenna?

[Space for Answers]

.....
.....
.....
.....
.....
.....
.....
.....
.....
.....
.....
.....
.....
.....
.....
.....
.....
.....
.....
.....
.....
.....
.....

XVIII References/Suggestions for further reading: include websites/links/Virtual lab Link

1. <https://ieeexplore.ieee.org/document/8681039>
2. <https://images.app.goo.gl/fLWsHetHg2v8u2LR9>

XIX Assessment Scheme

Performance Indicators		Weightage
Process Related (15 Marks)		60%
01	Identification of different blocks on trainer kit	10%
02	Connection made on kit	20%
03	Observation and Measurement taken	20%
04	Handling of equipment and Working in team	10%
Product Related (10 Marks)		40%
05	Interpretation of Results	15%
06	Conclusions	05%
07	Practical Related Questions	15%
08	Submission of Journal in time	05%
Total (25 Marks)		100 %

Marks Obtained			Dated Signature of Teacher
Process Related (15)	Product Related (10)	Total (25)	

Practical No. 20: Display faults in smart wristbands

I Practical Significance:

The experiment can reveal common manufacturing defects in the display, such as dead pixels, unresponsive touch areas, or inconsistent brightness. Regular testing helps ensure that all units meet the same quality standards. The experiment can identify how the display performs over time and under different conditions, such as exposure to moisture, sweat, and physical impacts.

II Industry / Employer Expected outcome(s)

The aim of this practical is to attend the following industry/employer expected outcome through various teaching learning experiences.

Maintain various consumer electronic appliances/equipment.

III Course Level Learning outcome(s)

- Use various smart appliances.

IV Laboratory Learning outcome(s)

- Display faults in smart wrist bands - a) display not working b) poor brightness

V Relevant Affective Domain related outcome(s)

1. Handle small parts with care
2. Follow safety precautions.

VI Relevant Theoretical Background.

Smart wristbands, also known as fitness trackers or smart bands, are compact wearable devices that offer various functionalities such as activity tracking, heart rate monitoring, notifications, and more. These devices typically include a small display to provide visual feedback to the user. However, display faults can occur, affecting the user experience.

Two common display faults are:

1. Display Not Working
2. Poor Brightness

Display faults can occur due to power issues, hardware failures or software issues. Poor brightness problem occurs mostly due to low battery, hardware or software issues.

VII Actual Circuit diagram used in a laboratory with related equipment rating.

a. Suggested kit/circuit diagram.

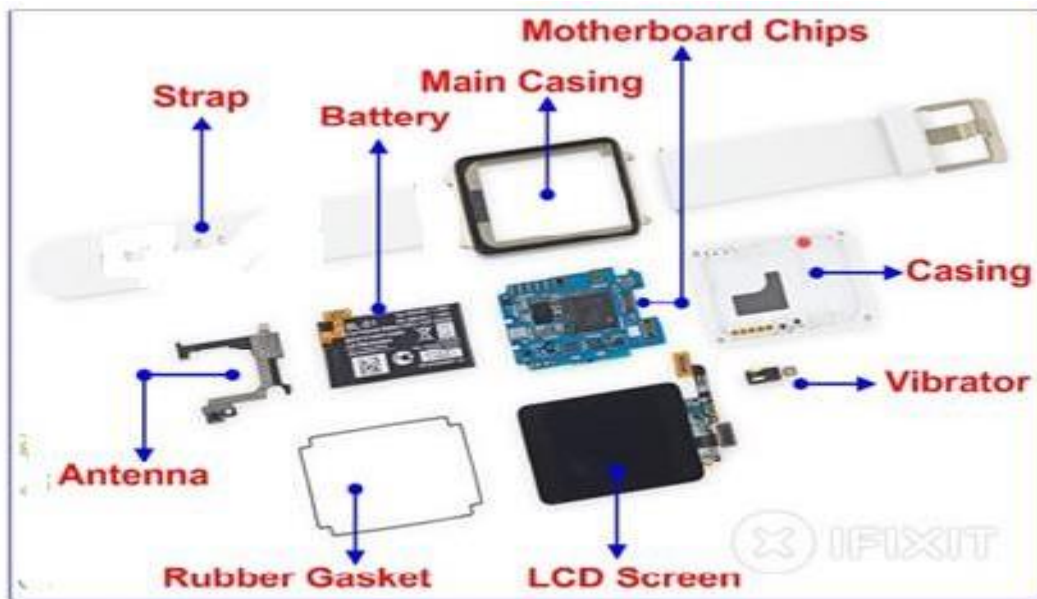

Figure 20.1: Smart wristband

b. Actual kit/circuit diagram.

VIII Required Resources/apparatus/equipment with specifications:

Sr. No.	Instruments/Components	Specifications	Quantity
1	Smart wristband with display fault	Bluetooth synchronization, low power accelerometer sensor, vibration motor support, operating temp -10°C to 50° C , system requirement –iOS 9.0 and above/Android 5.0 and above. (any other equivalent)	01
2	Multi-meter	Digital Multi-meter: 3 1/2 digit display	01
3	Torx screwdrivers or suitable tool for opening the wristband	Standard set	01
4	Cleaning materials	Isopropyl alcohol, microfiber cloth	01
5	Cables and connectors	Appropriate cables for connecting the scanner to the computer	01
6	Computer	A PC or laptop with the necessary ports	01

IX Precautions to be followed (Safety instructions / Rules / Standards)

1. Ensure the device is powered off before disassembling.
2. Handle electronic components with care to avoid static discharge.
3. Avoid using excessive force when opening the wrist band to prevent damage.

X Procedure:

Test the wires/cables/Electronic Components used for connections properly. If they are faulty then keep it in the proper E-waste bin.

A: Display Not Working:

1. Connect the wrist band to the charger using a known good cable and charger. – Allow it to charge for at least 30 minutes.
2. Attempt to power on the device by pressing and holding the power button. – If the display does not turn on, proceed to the next steps.
3. Check the display for any visible cracks or signs of moisture.
4. Use the appropriate tools to carefully open the wrist band. – Inspect the internal connections, particularly the display connector, for any signs of disconnection or damage.
5. Use a multimeter to check for continuity in the connections.
6. Check the software using reset button.
7. Connect the wrist band to the computer and check for available firmware updates.

B: Poor Brightness:

- 1 Increase the brightness level using display settings on the wrist band.
- 2 Clean the ambient light sensor with isopropyl alcohol and a microfiber cloth. .
- 3 Test the sensor by covering it and shining an external light source on it to see if the brightness adjusts accordingly.
- 4 Examine the display surface for signs of wear or degradation.
- 5 Clean the display with a microfiber cloth to remove any dirt or residue that might affect Brightness.

XI Required Resources

Sr. No.	Instruments/Components	Specifications	Quantity

XII Actual procedure followed

.....

.....

.....

.....

.....

.....

.....

.....

.....

.....

.....

.....

.....

.....

.....

.....

.....

.....

.....

.....

.....

.....

.....

XIII Observation table:

Fault	Troubleshoot stages	Observation
A: Display Not Working		
1	Check Battery Level	
2	Inspect for Physical damage	
3	Test Connections	
4	Software Reset	
5	Firmware Update	
B: Poor Brightness		
1	Adjust Brightness Settings	
2	Clean Light Sensor	
3	Open the Device	
4	Software Reset	
5	Firmware Update	

XIV Result(s):

.....

XV Interpretation of Results:

.....

XVI Conclusions and Recommendations:

.....

XVIII References/Suggestions for further reading: include websites/links/Virtual lab Link

- 1 <https://ieeexplore.ieee.org/document/8681039>
- 2 <https://images.app.goo.gl/mmUVDSmmzYtvSRkz9>
- 3 <https://images.app.goo.gl/fLWsHetHg2v8u2LR9>

XIX Assessment Scheme

Performance Indicators		Weightage
Process Related (15 Marks)		60%
01	Identification of different blocks on trainer kit	10%
02	Connection made on kit	20%
03	Observation and Measurement taken	20%
04	Handling of equipment and Working in team	10%
Product Related (10 Marks)		40%
05	Interpretation of Results	15%
06	Conclusions	05%
07	Practical Related Questions	15%
08	Submission of Journal in time	05%
Total (25 Marks)		100 %

Marks Obtained			Dated Signature of Teacher
Process Related (15)	Product Related (10)	Total (25)	

Practical No. 21: Data back-up from wearable device

I Practical Significance:

By implementing and regularly performing data back-ups, users can ensure the security and continuity of their wearable device data, enhancing the overall user experience and reliability of wearable technology.

II Industry / Employer Expected outcome(s)

The aim of this practical is to attend the following industry/employer expected outcome through various teaching learning experiences.

Maintain various consumer electronic appliances/equipment.

III Course Level Learning outcome(s)

- Use various smart appliances.

IV Laboratory Learning outcome(s)

- Take Back-up of data from wearable device such as wrist band to given drive/ storage device.

V Relevant Affective Domain related outcome(s)

1. Handle small parts with care
2. Follow safety precautions.

VI Relevant Theoretical Background.

Wearable devices, such as wristbands, collect and store various types of data, including health metrics (e.g., heart rate, steps, sleep patterns), notifications, and other personal information. Ensuring this data is backed up to a secure storage device is critical for data integrity, security, and continuity.

VII Actual Circuit diagram used in a laboratory with related equipment rating.

a. Suggested kit/circuit diagram.

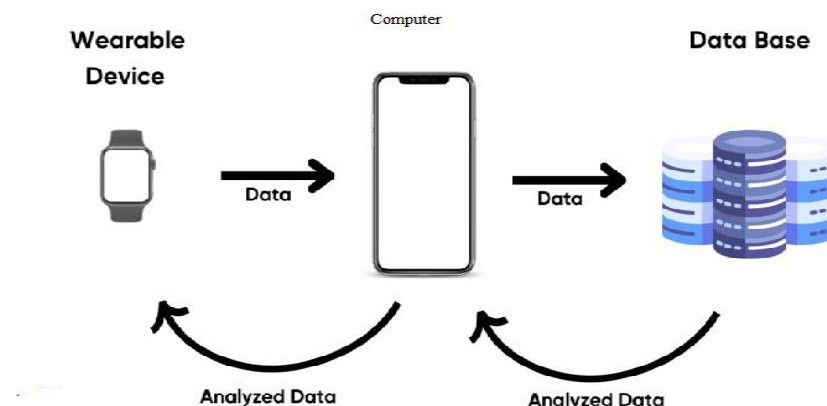

Figure 21.1: Data backup from wrist band to storage device

b. actual kit/circuit diagram.**VIII Required Resources/apparatus/equipment with specifications:**

Sr. No.	Instruments/Components	Specifications	Quantity
1	Smart wristband	Bluetooth synchronization, low power accelerometer sensor, vibration motor support, operating temp - 10°C to 50° C, system requirement –iOS 9.0 and above/Android 5.0 and above. (any other equivalent)	01
2	Storage device	External hard drive, USB flash drive, or cloud storage service.	01
3	Data transfer medium	USB cable (if using wired connection). Bluetooth or Wi-Fi (for wireless transfer).	01
4	Computer	A PC or laptop with the necessary ports	01

XIX Precautions to be followed (Safety instructions / Rules / Standards)

1. Ensure that the wearable device is fully charged to avoid interruptions during the backup Process.
2. Verify that there is enough free space on both the wearable device and the target storage Device.
3. Perform a quick check to ensure the data on the wearable device is complete and not Corrupted.
4. Utilize trusted software for backing up data from the wearable device.

X Procedure:

1. Test the wires/cables/Electronic Components used for connections properly. If they are faulty then keep it in the proper E-waste bin.
2. Pair the wearable device with the computer via Bluetooth, Wi-Fi or USB cable.
3. Initiate the data sync process to transfer data from the wearable device to the computer.
4. Connect the storage device to the computer.
5. Check the storage device to ensure data is successfully backed up.

XI Required Resources

Sr. No.	Instruments/Components	Specifications	Quantity
1			
2			
3			
4			

XII Actual procedure followed

.....

.....

.....

.....

.....

.....

XIII Observation table:

Sr. No.	Action	Observation
1	Bluetooth application ON/OFF	
2	Pair wearable device to computer	
3	Sync both devices	
4	Check data transfer to storage/ email	

XIV Result(s):

.....

.....

XV Interpretation of Results:

.....

.....

XVIII References/Suggestions for further reading: include websites/links/Virtual lab Link

- 1 <https://ieeexplore.ieee.org/document/8681039>
- 2 <https://images.app.goo.gl/fLWsHetHg2v8u2LR9>

XIX Assessment Scheme:

Performance Indicators		Weightage
Process Related (15 Marks)		60%
01	Identification of different blocks on trainer kit	10%
02	Connection made on kit	20%
03	Observation and Measurement taken	20%
04	Handling of equipment and Working in team	10%
Product Related (10 Marks)		40%
05	Interpretation of Results	15%
06	Conclusions	05%
07	Practical Related Questions	15%
08	Submission of Journal in time	05%
Total (25 Marks)		100 %

Marks Obtained			Dated Signature of Teacher
Process Related (15)	Product Related (10)	Total (25)	

Practical No. 22: Connection problems in VR headset

I Practical Significance:

Identifying and resolving connection problems can lead to a more stable and reliable VR experience, reducing frustration for users. can help minimize latency, which is crucial for maintaining immersion and preventing motion sickness in VR environments. By solving connection problems, VR technology can become more appealing to a broader audience. It can significantly contribute to improving the quality, safety, and user satisfaction of VR technology

II Industry / Employer Expected outcome(s)

The aim of this practical is to attend the following industry/employer expected outcome through various teaching learning experiences.

Maintain various consumer electronic appliances/equipment.

III Course Level Learning outcome(s)

- Use various smart appliances.

IV Laboratory Learning outcome(s)

- Test the VR headset problems - a) Bluetooth connectivity b) USB port connection.

V Relevant Affective Domain related outcome(s)

1. Handle the VR headset with care
2. Follow safety precautions.

VI Relevant Theoretical Background.

VR applications immerse the user in a computer-generated environment that simulates reality through the use of interactive devices, which send and receive information and are worn as goggles, headsets, gloves, or bodysuits. he VR headset is one of the most important wearables for users who want to immerse themselves in digital worlds. It replaces the natural field of view with a computer-generated field of view. To make that happen, the wearable integrates infrared LEDs, motion sensors, cameras and screens. They all enable headset to gather relevant information and provide it for the human eye. VR technology is often the VR used in the gaming industry, but it has plenty of applications in other sectors. For example, therapists are now combining VR technology with traditional therapeutic approaches to treat mental health conditions, such as severe phobias and cases of post- traumatic stress disorder (PTSD).

VII Actual Circuit diagram used in a laboratory with related equipment rating.

a. Suggested kit/circuit diagram.



Figure 22.1: VR headset

b. Actual kit/circuit diagram used in laboratory

VIII Required Resources/apparatus/equipment with specifications:

Sr. No.	Instruments/Components	Specifications	Quantity
1	VR headset	Max Resolution 3664×1920 per eye, Screen Type Fast Twitch LCD, Max Refresh Rate-120Hz, Tracking 6DOF Inside Out Tracking (wireless). (any other equivalent) .	01
2	Computer/Smartphone	Laptop, Desktop PC/Android phone with internet	01
3	VR applications or games	Any suitable application to test connectivity in real-use scenarios	01
4	Bluetooth signal strength meter	free Android application	01

IX Precautions to be followed (Safety instructions / Rules / Standards)

1. Ensure that there are no other Bluetooth devices operating nearby that could interfere with the signal.
2. Ensure that both the VR headset and the Bluetooth-enabled devices have sufficient battery levels.
3. Ensure that the USB cable is securely plugged into both the VR headset and the connecting device.
4. Ensure that the appropriate drivers for the VR headset are installed

X Procedure:

Test the wires/cables/Electronic Components used for connections properly. If they are faulty then keep it in the proper E-waste bin.

A) Bluetooth Connectivity Testing:

- 1 Ensure VR headset and testing devices are fully charged.
- 2 Set up the VR headset and pair it with the test device using Bluetooth.
- 3 Place the VR headset at different distances from the Bluetooth source (e.g., 1m, 5m, 10m).
- 4 Use Bluetooth signal strength meter to measure signal strength .
- 5 Note the readings by varying the distance.

B) USB Port Connection Testing:

- 1 Connect the VR headset to the test device using a USB cable.
- 2 Connect the VR headset to different USB ports (e.g., USB 2.0, 3.0, 3.1) on the test Device.
- 3 Check the connection stability for each port.

XI Required Resources

Sr. No.	Instruments/Components	Specifications	Quantity
1			
2			
3			
4			

XII Actual procedure followed

.....

.....

.....

.....

.....

.....

.....

.....

.....

.....

.....

.....

.....

.....

.....

.....

.....

.....

.....

.....

.....

.....

XIII Observation table:

A) Bluetooth Connectivity Testing

Sr. No.	Distance(m)	Bluetooth version	Signal strength
1	5	5.0	
2	10	5.0	
3	15	5.0	

B) USB Port Connection Testing

Sr. No.	USB Cable Length (m)	USB Port Type	Connection Stability
1	1	USB 3.0	
2	1	USB 2.0	

XIV Result(s):

.....

XV Interpretation of Results:

.....

XVI Conclusions and Recommendations:

.....

XVIII References/Suggestions for further reading: include websites/links/Virtual lab Link

1 <https://uu.diva-portal.org/smash/get/diva2:1196010/FULLTEXT01.pdf>

2 <https://images.app.goo.gl/NXs5fLsiqNem8hpx9>

XIX Assessment Scheme:

Performance Indicators		Weightage
Process Related (15 Marks)		60%
01	Identification of different blocks on trainer kit	10%
02	Connection made on kit	20%
03	Observation and Measurement taken	20%
04	Handling of equipment and Working in team	10%
Product Related (10 Marks)		40%
05	Interpretation of Results	15%
06	Conclusions	05%
07	Practical Related Questions	15%
08	Submission of Journal in time	05%
Total (25 Marks)		100 %

Marks Obtained			Dated Signature of Teacher
Process Related (15)	Product Related (10)	Total (25)	

Practical No. 23: Performance of VR headset

I Practical Significance:

The practical significance of testing and improving VR headset performance, particularly regarding connectivity, extends across various domains including user experience, device reliability, technical understanding, product development, health and safety, specific applications, and economic impact. These experiments are essential for advancing VR technology and ensuring it meets the growing demands of users and applications

II Industry / Employer Expected outcome(s)

The aim of this practical is to attend the following industry/employer expected outcome through various teaching learning experiences.

Maintain various consumer electronic appliances/equipment.

III Course Level Learning outcome(s)

- Use various smart appliances.

IV Laboratory Learning outcome(s)

- Use the controllers of VR headset to navigate within the virtual environment.

V Relevant Affective Domain related outcome(s)

1. Handle small parts with care
2. Follow safety precautions.

VI Relevant Theoretical Background.

VR controller is a handheld device that allows users to interact with the virtual environment. It acts as an extension of your hand, allowing you to manipulate objects, navigate menus, and perform various actions within the virtual world. A VR controller typically consists of buttons, triggers, thumb sticks, and sensors that track your hand movements and translate them into actions in the virtual world. These controllers are designed to be lightweight and comfortable, allowing for extended use without causing fatigue or discomfort.

The buttons on a VR controller are often used for basic interactions, such as selecting objects or navigating menus. Triggers, on the other hand, are usually used for more precise actions, like shooting a virtual gun or grabbing an object. Thumb sticks provide analog input, allowing for smooth and precise movement within the virtual environment. In addition to these input methods, VR controllers often incorporate sensors that track the position and orientation of the controller in real-time. This tracking technology enables accurate and responsive interactions, making you feel like you are truly present in the virtual world.

VII Actual Circuit diagram used in a laboratory with related equipment rating.
a. Suggested equipment

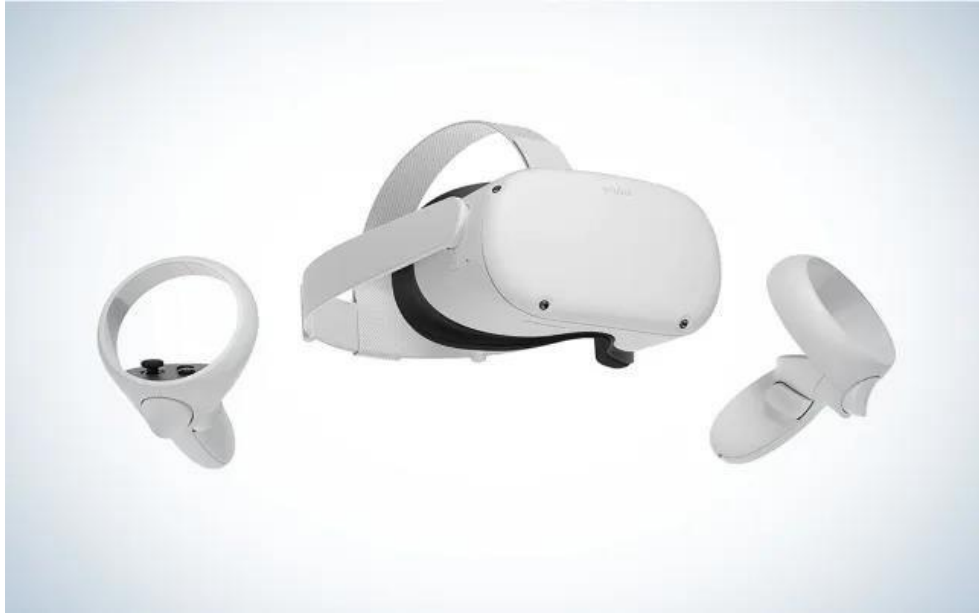

Figure 23.1 VR Headset controllers

b. Actual equipment used in laboratory

VIII Required Resources/apparatus/equipment with specifications:

Sr. No.	Instruments/Components	Specifications	Quantity
1	VR headset	Max Resolution 3664×1920 per eye, Screen Type Fast Twitch LCD, Max Refresh Rate-120Hz, Tracking 6DOF Inside Out Tracking (wireless). (any other equivalent)	01
2	Controllers	Compatible with the chosen headset.	01
3	Virtual environment	A pre-designed virtual environment with various navigation challenges (e.g., mazes, open spaces, interactive objects).	01
4	Computer	Any suitable desktop PC or laptop	01

IX Precautions to be followed (Safety instructions / Rules / Standards)

1. Remove any obstacles, tripping hazards, or sharp objects from the surrounding area .
2. Ensure the user is wearing comfortable, non-slip footwear to reduce the risk of slipping.
3. Check and charge the controllers and headset

X Procedure:

1. Test the wires/cables/Electronic Components used for connections properly. If they are faulty then keep it in the proper E-waste bin.
2. Connect the VR headset and controllers to the computer or console.
3. Open the chosen VR application or game on the computer or console.
4. Test the different controllers available.
5. Note the function of buttons, sensors available on the controller.

XI Required Resources

Sr. No.	Instruments/Components	Specifications	Quantity
1			
2			
3			
4			
5			

XII Actual procedure followed

.....

.....

.....

.....

.....

.....

.....

.....

.....

.....

XIII Observation table:

Sr. No.	Controller Name	Function
1	Menu button	
2	System/home button	
3	Primary trigger	
4	Secondary trigger	
5	Movement thumb stick	
6	Directional thumb stick	
7	Position and orientation sensor	
8	Capacitive Touch Sensors	

XIV Result(s):

.....

.....

XV Interpretation of Results:

.....

.....

XVIII References/Suggestions for further reading: include websites/links/Virtual lab Link

1. <https://uu.diva-portal.org/smash/get/diva2:1196010/FULLTEXT01.pdf>
2. <https://images.app.goo.gl/NXs5fLsiqNem8hpx9>
3. https://youtu.be/C7iJWO7Q_Uk?si=R2hTgzyeJD_wB5BT

XIX Assessment Scheme:

Performance Indicators		Weightage
Process Related (15 Marks)		60%
01	Identification of different blocks on trainer kit	10%
02	Connection made on kit	20%
03	Observation and Measurement taken	20%
04	Handling of equipment and Working in team	10%
Product Related (10 Marks)		40%
05	Interpretation of Results	15%
06	Conclusions	05%
07	Practical Related Questions	15%
08	Submission of Journal in time	05%
Total (25 Marks)		100 %

Marks Obtained			Dated Signature of Teacher
Process Related (15)	Product Related (10)	Total (25)	

Practical No. 24: Interfacing of Laser Printer

I Practical Significance

Interfacing of laser printers is the process of connecting and communicating with the printer from a computer or network, enabling users to send print jobs, adjust settings, and manage print tasks effectively.

II Industry / Employer Expected outcome(s)

The aim of this practical is to attend the following industry/employer expected outcome through various teaching learning experiences.

Maintain various consumer electronic appliances/equipment.

III Course Level Learning outcome(s)

- Maintain various office automation appliances.

IV Laboratory Learning outcome(s)

- Interface Laser Printer to the desktop computer and identify various controls.

V Relevant Affective Domain related outcome(s)

1. Handle equipment carefully.
2. Follow safety precautions.

VI Relevant Theoretical Background.:

Laser printers are an output device which uses an electrostatic digital printing process to produce high quality graphics and texts. Working of a laser printer can be described as a three- step process.

- 1. Receiving data from the host PC**
- 2. Processing the received data into dots**
- 3. Converting dots into permanent image on paper**

1. Receiving data from the host PC:

When a user makes a request for printing in an application, the application passes on the request to the OS, which establishes communication with the hardware services in the PC that are needed for communicating with the printer. The Interface controller of the formatter PCA receives input from the PC and as the name indicates, formats it for printing. So, all input ports on the printer, including parallel, serial, USB, network, and infra-red, plug into the formatter.

2. Processing the received data into dots:

After the printer receives the data from the PC, the controller part of the formatter processes the data. The data processing can be divided into three steps:

b. Interpreting the received data:

The printer controller CPU begins interpreting or processing the received data with the help of the firmware stored in the ROM that supports the Page Description Language (PDL) that the printer uses. The interpretation process starts with examination of the incoming data to distinguish the control commands from the actual content of the document.

c. Formatting the interpreted data:

The formatting process involves the interpretation of the commands that decide how the data will be placed on the page. The formatting process differs depending on the processing capabilities of the printer.

d. Rasterizing the formatted page:

In the final stage of processing the data, the controller converts the bit-mapped page into a pattern of tiny dots that will be created on the print media. This process is called rasterization. The array of dots is then stored in a page buffer and ready for printing.

3. Converting dots into permanent image on paper :

Inside a Laser printer the image formation process revolves around the Organic Photoconductive (OPC) drum. The conversion of the raster dots in printer buffer into a complete image on paper consists of the following steps:

1. Cleaning of the OPC Drum.
2. Conditioning of the OPC Drum.
3. Writing the image onto the OPC Drum using Laser.
4. Developing the image on the OPC Drum with Toner.
5. Transferring the toner image from OPC drum to the paper, and Fusing the image permanently on the paper.

VII Laser Printer connection diagram used in a laboratory with related equipment rating.**a. Suggested Kit / Connection Diagram:**

Figure 24.1. Laser printer connection diagram with Personal Computer.

b. Actual Circuit diagram/Kit used in a laboratory with related equipment rating.**VIII Required Resources/apparatus/equipment with specifications:**

Sr. No.	Instruments/Components	Specifications	Quantity
01	Device to connect (e.g. Computer)	PC with Windows 10	01
02	Laser Printer	Hp or Canon laser printer	01
03	Printer cable	USB 2.0 A/B	01
04	Printer paper	A4 size	

IX Precautions to be followed (Safety instructions / Rules / Standards)

1. Ensure printer cable is connected to the printer and computer.
2. Switch on Personal computer and printer after proper connection of power supply.

X Procedure:

1. Test the wires/cables/Electronic Components used for connections properly. If they are faulty then keep it in the proper E-waste bin.
2. Connect the printer's cable to the computer. Most printers use a USB connection.
3. Turn on your printer.
4. Open "**Devices and Printers**". through the "**Control Panel**", or simply search on the computer via the magnifying glass icon near the Start button.
5. Once inside the Devices and Printers menu, click on "**Add a Printer**".
6. The name of the printer should show up from the menu. Select the exact name of the printer, and click on it.
7. Windows will then automatically handle the installation by processing the appropriate drivers.
8. Wait for the installation to finish. After completion of installation the "**Finish**" button will be activated.
9. Before clicking Finish, do a test print first.
10. To accomplish a printing test, make sure the paper and ink cartridges are ready. Then, simply click the "**Print a test page**" button from the installation window.
11. If the print test turns out okay, click that Finish button and installation is done!

XI Required Resources

Sr. No.	Instruments/Components	Specifications	Quantity
1			
2			
3			
4			

XII Actual procedure followed

.....

.....

.....

.....

.....

.....

.....

.....

XIII Observation table

Sr. No.	Functions to be performed while installation process	Instruction appeared on computer screen	Observations on printer
1.	Add printer from drive		
2.	Installation of printer		
3.	Test print		

XIV Result(s):

.....

.....

XV Interpretation of Results:

.....

.....

XVI Conclusions and Recommendations:

.....

.....

XVIII References/Suggestions for further reading: include websites/links/Virtual lab Link

- 1 <https://i.ytimg.com/vi/c8DF92JjxJY/maxresdefault.jpg>
- 2 <https://www.geeksforgeeks.org/how-laser-printer-works/>

XIX Assessment Scheme

Performance Indicators		Weightage
Process Related (15 Marks)		60%
01	Identification of different blocks on trainer kit	10%
02	Connection made on kit	20%
03	Observation and Measurement taken	20%
04	Handling of equipment and Working in team	10%
Product Related (10 Marks)		40%
05	Interpretation of Results	15%
06	Conclusions	05%
07	Practical Related Questions	15%
08	Submission of Journal in time	05%
Total (25 Marks)		100 %

Marks Obtained			Dated Signature of Teacher
Process Related (15)	Product Related (10)	Total (25)	

Practical No. 25: Fault analysis of cartridge related problems of Laser printer

I Practical Significance

Troubleshooting laser printer issues like toner issue, paper jams, print quality problems, connectivity issues, or error messages can be resolved by understanding the root causes and implementing the appropriate troubleshooting steps, laser printers continue to perform optimally, providing high-quality prints timely.

II Industry / Employer Expected outcome(s)

The aim of this practical is to attend the following industry/employer expected outcome through various teaching learning experiences.

Maintain various consumer electronic appliances/equipment.

III Course Level Learning outcome(s)

- Maintain various office automation appliances.

IV Laboratory Learning outcome(s)

- Detect and remove the faults in laser printer:-
 - a) The print quality is not very good.
 - b) White lines and streaks.
 - c) cartridge leakage.

V Relevant Affective Domain related outcome(s)

1. Handle equipment carefully.
2. Follow safety precautions.

VI Relevant Theoretical Background.

Troubleshooting a laser printer involves identifying and resolving common issues that can arise during its operation. Here's a structured approach to troubleshoot laser printers effectively:

Check Power and Connections

- **Power:** Ensure the printer is plugged in and turned on. Check power cables and outlets.
- **Connections:** Verify all cables (USB, Ethernet, power) are securely connected to the printer and the computer or network.

1. Printer Display and Status Lights

- **Status Lights:** Interpret the meaning of status lights (e.g., error, ready, low toner) by referring to the printer's manual or online resources.

2. Print Jobs

- **Print Queue:** Check the print queue on the computer to see if there are any pending jobs or errors.
- **Cancel Jobs:** Clear any stuck print jobs that may be causing issues.

3. Paper Jams

- **Locate Jams:** Open appropriate panels and trays to find and remove any paper jams.

Follow the printer's manual for specific instructions on clearing jams

4. Toner and Cartridge Issues

- **Low Toner:** Replace toner cartridges if they are low or empty. Follow the printer's manual for the correct procedure.
- **Cartridge Installation:** Ensure cartridges are properly installed and seated.

5. Print Quality Issues

- **Blurred or Faded Prints:** Check toner levels and replace cartridges if necessary. Clean the printer's interior components such as the drum or fuser.
- **Smudges or Lines:** Clean the printer's rollers and ensure the paper path is clear of debris.

6. Driver and Software

- **Update Drivers:** Ensure printer drivers are up to date. Download and install the latest drivers from the manufacturer's website if needed.
- **Reinstall Software:** Reinstall printer software if the printer is not recognized or if there are software conflicts.

9. Reset and Restart

- **Power Cycle:** Turn off the printer, wait for a few minutes, then turn it back on. This can resolve temporary issues.
- **Factory Reset:** As a last resort, perform a factory reset according to the printer's manual to restore default settings.

10. Consult Documentation and Support

- **Manuals:** Refer to the printer's manual for specific troubleshooting steps and error code explanations.
- **Manufacturer Support:** Contact the manufacturer's support team or visit their website for additional troubleshooting guidance or to seek warranty service if the issue persists.

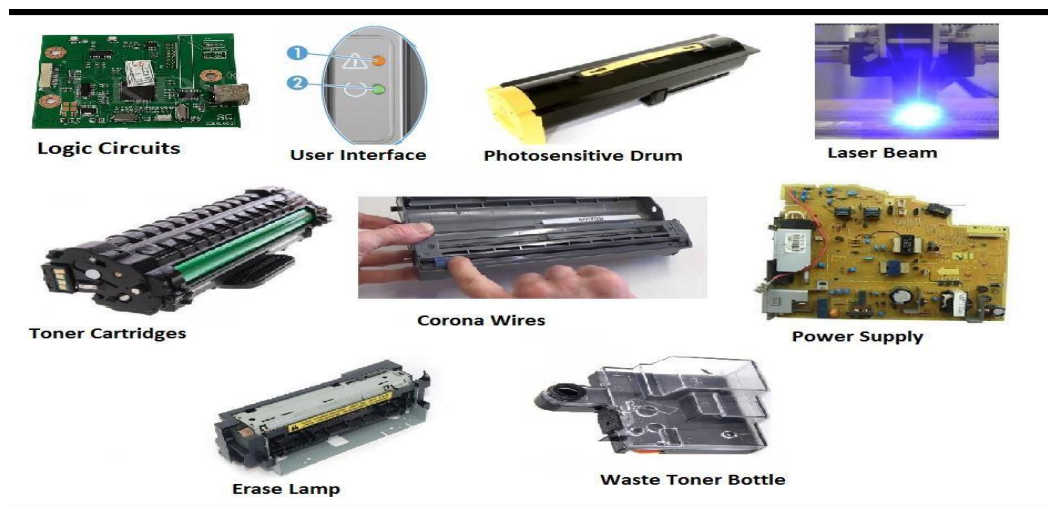

Figure 25.1. Components of Laser printers.

VII Laser printer trainer kit/ diagram used in a laboratory with related equipment rating.

a. Suggested Kit / Circuit Diagram:



Figure 25.2. Laser printers.

b. Actual Circuit diagram/Kit used in a laboratory with related equipment rating.

VIII Required Resources/apparatus/equipment with specifications:

Sr. No.	Instruments/Components	Specifications	Quantity
01	Device to connect (e.g. Computer)	PC with Windows 10	01
02	Laser Printer	Hp or Canon laser printer	01
03	Additional Printer cartridge	Hp or Canon laser printer With variable toner quantity	02
04	Printer cable	USB 2.0 A/B	01
05	Printer paper	A4 size	

IX Precautions to be followed (Safety instructions / Rules / Standards)

- 1 Switch on Personal computer and printer after proper connection of power supply.

X Procedure:

- 1 Test the wires/cables/Electronic Components used for connections properly. If they are faulty then keep it in the proper E-waste bin.
- 2 Connect the printer's cable to the computer. Most printers use a USB connection.
- 3 Turn on the computer and printer and select the document for print on the computer.
- 4 To accomplish a printing test for, make sure the paper and ink cartridges are ready. Then, open the document which is to be printed as a sample test Print. Click on the "Print" option from the menu and take a sample printout.
- 5 If the printed document is correct means your cartridge is good.
- 6 Change the other two cartridges one by one with low quantity toner and repeat procedure of point no.3 and check the final printout.

XI Required Resources

Sr. No.	Instruments/Components	Specifications	Quantity

XII Actual procedure followed

.....

.....

.....

.....

.....

.....

.....

.....

XIII Observation table:

Sr. No.	Parameter	Indication on printer	Instruction on computer screen
1.	Prints with Cartridge 1		
2.	Prints with Cartridge 2		
3.	Prints with Cartridge 3		
4.	Cartridge ink empty		
5.	Paper tray empty		
6.	Paper Jam		

XIV Result(s):

.....

XV Interpretation of Results:

.....

XVI Conclusions and Recommendations:

.....

XVII Practical Related Questions:

Note: Below given are few sample questions. Teachers must design such questions to ensure achievement of identified CO.

- 1 List typical symptoms of a faulty laser printer cartridge?
- 2 What action will you take if the printer displays a "Cartridge Error" message?
- 3 Explain how to prevent toner spills or leaks when handling a laser printer cartridge?
- 4 What are the main causes of cartridge-related faults in laser printers?

XVIII References/Suggestions for further reading: include websites/links/Virtual lab Link

- 1 <https://i.ytimg.com/vi/c8DF92JjxJY/maxresdefault.jpg>
- 2 <https://www.geeksforgeeks.org/how-laser-printer-works/>

XIX Assessment Scheme:

Performance Indicators		Weightage
Process Related (15 Marks)		60%
01	Identification of different blocks on trainer kit	10%
02	Connection made on kit	20%
03	Observation and Measurement taken	20%
04	Handling of equipment and Working in team	10%
Product Related (10 Marks)		40%
05	Interpretation of Results	15%
06	Conclusions	05%
07	Practical Related Questions	15%
08	Submission of Journal in time	05%
Total (25 Marks)		100 %

Marks Obtained			Dated Signature of Teacher
Process Related (15)	Product Related (10)	Total (25)	

Practical No. 26: Performance of Laser Printer

I Practical Significance

Laser printer performance lies in its ability to deliver fast, high-quality prints reliably and cost-effectively, thereby supporting productivity, efficiency, and operational effectiveness in various professional and educational settings.

II Industry / Employer Expected outcome(s)

The aim of this practical is to attend the following industry/employer expected outcome through various teaching learning experiences.

Maintain various consumer electronic appliances/equipment

III Course Level Learning outcome(s)

- Maintain various office automation appliances.

IV Laboratory Learning outcome(s)

- Measure the speed of given laser printer.

V Relevant Affective Domain related outcome(s)

1. Handle equipment carefully.
2. Follow safety precautions.

VI Relevant Theoretical Background.

The performance of laser printer depends on the following parameters which are to be considered while selection of the printer

1. **Print Speed:** Laser printers are known for their fast print speeds, which is crucial in environments where quick turnaround times are essential. Print speed is measured in pages per minute (ppm) and varies depending on the printer model and specifications. High-speed printing reduces waiting times and increases productivity.
2. **Print Quality:** Laser printers produce high-quality prints characterized by sharp text and images. The resolution of laser printers is measured in dots per inch (dpi), with higher dpi values leading to clearer and more detailed prints. This high print quality is advantageous for professional documents, graphics, and marketing materials.
3. **Reliability and Durability:** Laser printers are designed for durability and reliability, making them suitable for high-volume printing environments. They can handle large print jobs continuously without frequent breakdowns or maintenance issues, ensuring consistent performance over time.

4. **Paper Handling:** Laser printers offer versatile paper handling capabilities, including support for various paper sizes (e.g., letter, legal, A4), weights, and types (e.g., plain, recycled, glossy). They often include multiple paper trays and options for duplex (double-sided) printing, enhancing flexibility and efficiency in printing operations.
5. **Connectivity Options:** Modern laser printers typically come with various connectivity options such as USB, Ethernet, and Wi-Fi. This allows users to connect the printer to multiple devices within a network, facilitating shared printing and enabling mobile printing from smartphones and tablets.
6. **Toner Efficiency:** Laser printers use toner cartridges that are more efficient compared to inkjet printers in terms of cost per page. Toner cartridges have higher page yields and require less frequent replacement, resulting in lower operating costs over time.
7. **Energy Efficiency:** Laser printers are generally more energy-efficient than inkjet printers, particularly in office environments with frequent printing needs. Energy-saving features such as sleep mode and automatic power-off contribute to reducing electricity consumption and operational costs.
8. **Noise Level:** Laser printers tend to operate more quietly than older models, but noise levels can vary depending on the printer's design and print speed. Quieter operation is beneficial in shared office spaces or environments where noise reduction is important.
9. **User Interface and Ease of Use:** The user interface of a laser printer, including its control panel and software interface, plays a role in user experience. Intuitive controls, clear menus, and user-friendly software contribute to ease of operation and efficiency in printing tasks.
10. **Security Features:** Many laser printers are equipped with advanced security features such as secure printing, user authentication, and data encryption. These features help protect sensitive information and prevent unauthorized access to printed documents, making laser printers suitable for environments with strict security requirements.

Overall, the performance of a laser printer is characterized by its speed, print quality, reliability, efficiency, connectivity options, and user-friendly features. These factors collectively determine the printer's effectiveness in meeting the printing needs of businesses, offices, educational institutions, and other professional environments.

VII Actual Circuit diagram used in a laboratory with related equipment rating.

a. Suggested Kit / Circuit Diagram:



Figure 26.1 Laser printers.

b. Actual diagram/Kit used in a laboratory with related equipment rating.

VIII Required Resources/apparatus/equipment with specifications:

Sr. No.	Instruments/Components	Specifications	Quantity
01	Device to connect (e.g. Computer)	PC with Windows 10	01
02	Laser Printer	Hp or Canon laser printer	01
03	Printer cable	USB 2.0 A/B	01
04	Printer paper	A4 size	

IX Precautions to be followed (Safety instructions / Rules / Standards)

1. Ensure printer cable is connected to the printer and computer.
2. Switch on Personal computer and printer after proper connection of power supply.

X Procedure:

1. Test the wires/cables/Electronic Components used for connections properly. If they are faulty then keep it in the proper E-waste bin.
2. Connect the printer's cable to the computer. Most printers use a USB connection.
3. Turn on your printer.
4. Complete installation process of the printer. After completion of installation the "**Finish**" button will be activated.
5. Before clicking Finish, do a test print first.
6. To accomplish a printing test, make sure the paper and ink cartridges are ready. Then, simply click the "**Print a test page**" button from the installation window.
7. After completion of the sample test Print, open the document from the computer to have more printouts. Click on the "Print" option from the menu and take more sample printouts.
8. Measure the speed of printout for single page and multiple pages per minute and record the performance of laser printers.
9. If all the printed documents are correct means your cartridge is good.

XI Required Resources

Sr. No.	Instruments/Components	Specifications	Quantity

XII Actual procedure followed

.....

.....

.....

.....

.....

.....

.....

.....

.....

.....

.....

.....

.....

.....

.....

.....

.....

.....

.....

.....

.....

.....

.....

XIII Observation table:

Sr. No.	Page	Quantity of papers to print	Speed in pages per minutes (PPM)
1.	Text Speed	Single Page (Page 1)	
2.		Long Print Page (Pages 2 to 5)	
3.	Graphics Speed	Single Page	

XIV Result(s):

.....

.....

XV Interpretation of Results:

.....

.....

XVI Conclusions and Recommendations:

.....

.....

XVIII References/Suggestions for further reading: include websites/links/Virtual lab Link.

- 1 <https://i.ytimg.com/vi/c8DF92JjxJY/maxresdefault.jpg>
- 2 <https://www.geeksforgeeks.org/how-laser-printer-works/>

XIX Assessment Scheme:

Performance Indicators		Weightage
Process Related (15 Marks)		60%
01	Identification of different blocks on trainer kit	10%
02	Connection made on kit	20%
03	Observation and Measurement taken	20%
04	Handling of equipment and Working in team	10%
Product Related (10 Marks)		40%
05	Interpretation of Results	15%
06	Conclusions	05%
07	Practical Related Questions	15%
08	Submission of Journal in time	05%
Total (25 Marks)		100 %

Marks Obtained			Dated Signature of Teacher
Process Related (15)	Product Related (10)	Total (25)	

Practical No. 27: Interfacing of LED Projector

I Practical Significance:

A projector is a device that allows you to project images onto a screen or another surface using light. An LED projector is a projector that employs LEDs as its light source instead of mercury or xenon lamps. Interfacing a LED projector involves connecting the projector to a device such as a computer, DVD player, or streaming device, and configuring the settings to ensure proper display.

II Industry / Employer Expected outcome(s)

The aim of this practical is to attend the following industry/employer expected outcome through various teaching learning experiences.

Maintain various consumer electronic appliances/equipment.

III Course Level Learning outcome(s)

- Maintain various office automation appliances.

IV Laboratory Learning outcome(s)

- Interface and configure LED Projector using various controls

V Relevant Affective Domain related outcome(s)

1. Handle equipment carefully.
2. Follow safety precautions.

VI Relevant Theoretical Background.

An LED projector is a type of projector that uses light-emitting diodes (LEDs) as its light source instead of traditional lamps. LED projectors offer several advantages over traditional projectors, including longer lifespan, lower power consumption, and more vibrant colors. However, they also have some disadvantages, such as lower brightness levels and higher initial cost. LED projectors are commonly used in home theaters, classrooms, and business presentations. It is a modern technology that has revolutionized the way we watch movies, play games, and give presentations.

LED projectors are advantageous due to their compact size, energy efficiency, and long lifespan. Unlike lamp-based projectors that transform the white light into colors, LED projectors directly generate colors by combining LEDs in three colors of light: red, green and blue. This solution provides a wider color palette that results in both more natural and vivid colors.

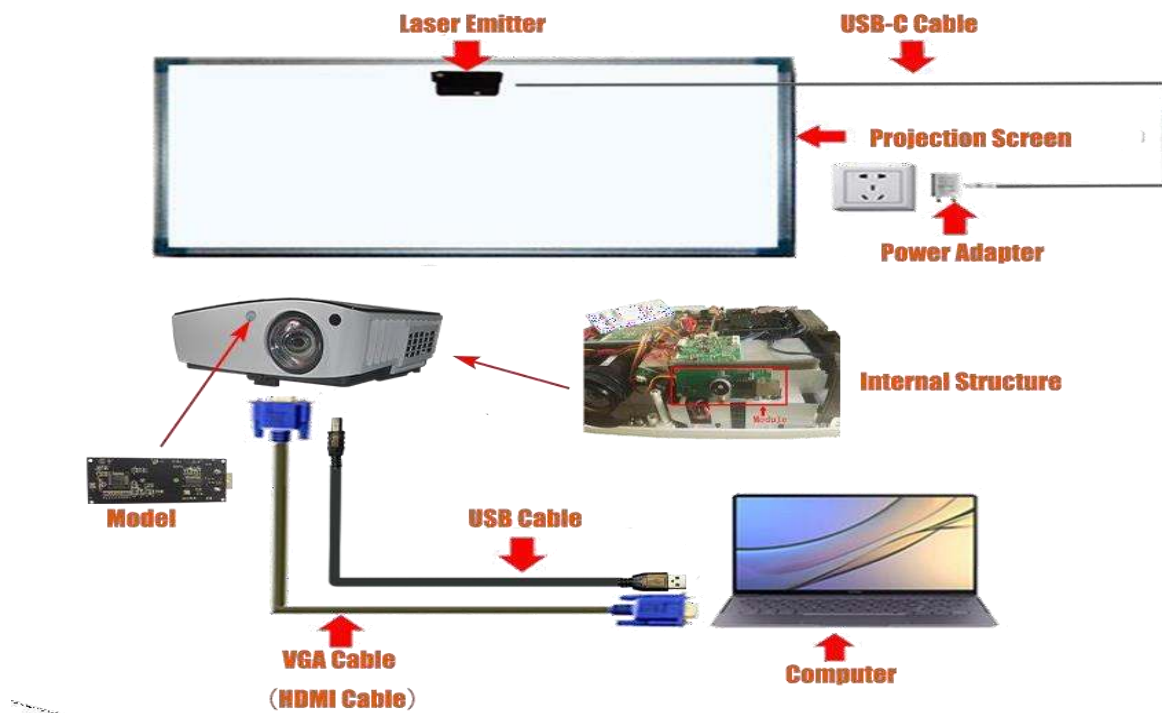

Figure 27.1. Connection diagram of LED projector with PC

Control front panel	Rear panel	
1.STANDBY/ON button	1. AUDIO IN1 port	7. CONTROL port
2.INPUT button	2. AUDIO IN2 port	8. VIDEO port
3.MENU button It consists of four cursor buttons	3. COMPUTER IN1 port	9.S-VIDEO port
4.POWER indicator	4.COMPUTER IN2 port	10.AUDIO IN3 (R, L) ports
5.TEMP indicator	5.MONITOR OUT port	11. AUDIO OUT (R, L) ports
6.LAMP indicator	6.Shutdown switch	

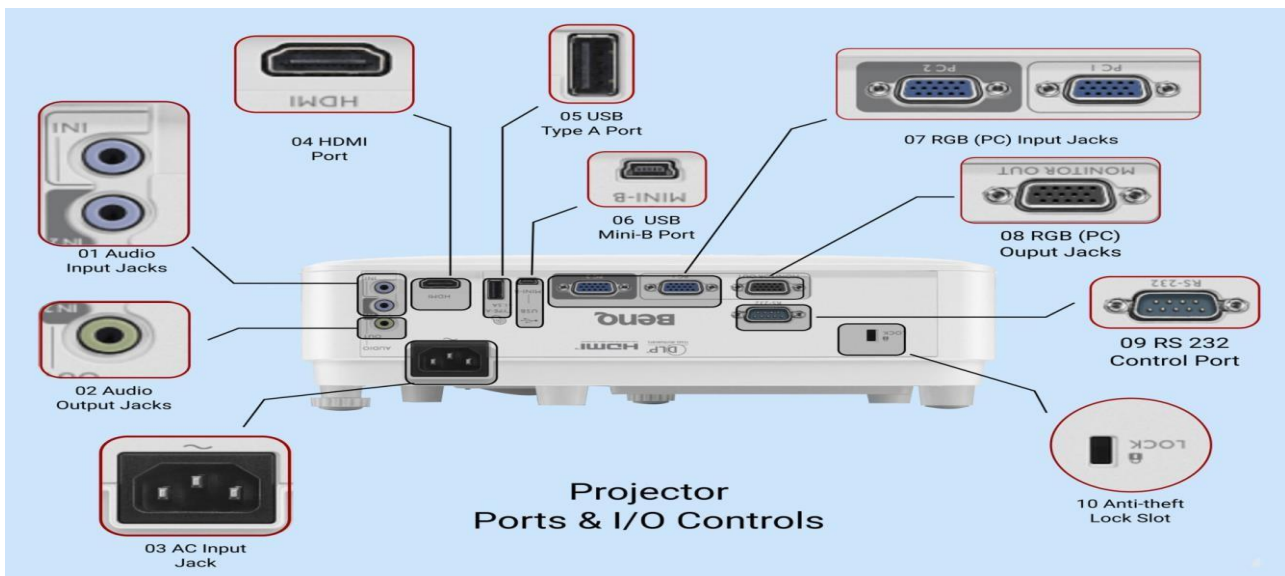

Figure 27.2. LED projector with Ports and controls

VII Actual Circuit diagram used in a laboratory with related equipment rating.
 a Suggested Kit / Circuit Diagram:

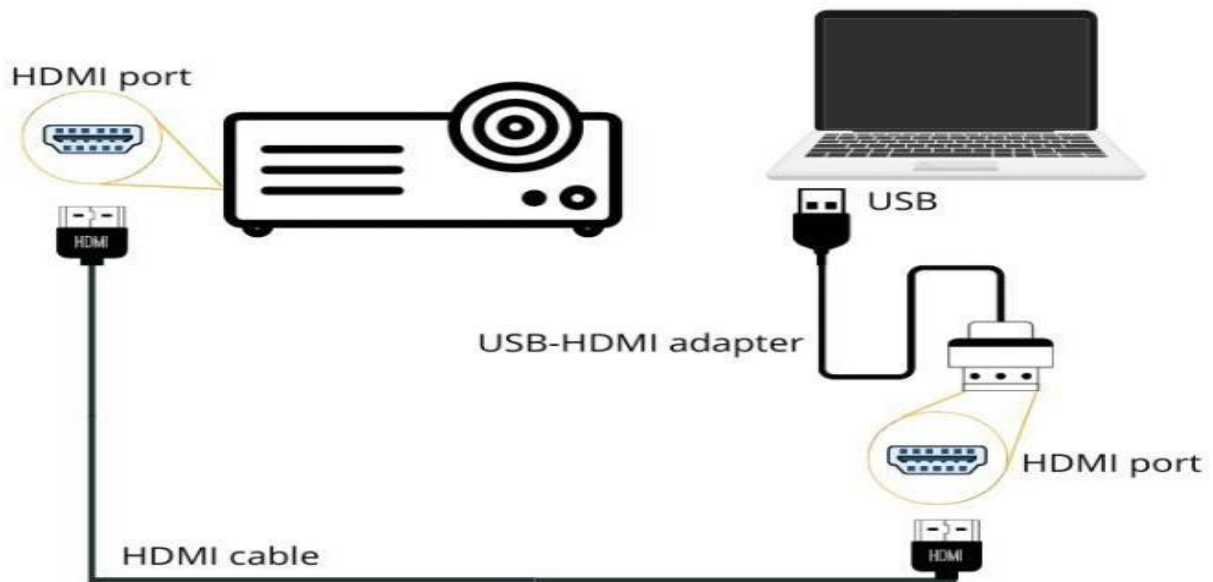

Figure 27.3. LED projector Connection diagram

a. Actual Circuit diagram/Kit used in a laboratory with related equipment rating.**VIII Required Resources/apparatus/equipment with specifications:**

Sr. No.	Instruments/Components	Specifications	Quantity
01	LED Projector	Native 1080p Full HD resolution	01
02	Device to connect (e.g. Computer)	PC with Windows 10	01
03	HDMI, VGA, or other compatible cables	HDMI 2.1a	01
04	Power source	230V, 50Hz	01

IX Precautions to be followed (Safety instructions / Rules / Standards)

1. Ensure all cables are securely connected to avoid signal loss or interference.
2. Check the resolution settings on both the source device and the projector to match for the best image quality.
3. Keep the projector's lens clean for optimal clarity.
4. If you encounter any issues, consult the user manual for troubleshooting tips or seek assistance from the manufacturer's customer support.

X Procedure:

1. Test the wires/cables/Electronic Components used for connections properly. If they are faulty then keep it in the proper E-waste bin.
2. Set up the LED projector on a stable surface, preferably facing the screen or wall where you want to display the image.
3. Plug the power cord into the LED projector and connect it to a power outlet.
4. Connect one end of the appropriate cable (HDMI, VGA) to the output port of the source device.

XIII Observation table:

Sr. No.	Section	Message displayed as	Connections required to perform
1	Video Section	No input is detected SYNC is out of range Invalid scan Frequency	
2	Audio Section	No Audio output	
3	Control Section	Check the air flow	

XIV Result(s):

.....

.....

XV Interpretation of Results:

.....

.....

XVI Conclusions and Recommendations:

.....

.....

XVII Practical Related Questions:

Note: Below given are few sample questions. Teachers must design such questions to ensure achievement of identified CO

- 1 Define LED projector.
- 2 What are the different applications of LED projector?
- 3 What are the common ports available with LED projector?
- 4 What are the different types of cables required for interfacing the LED projector?
- 5 List out various features of LED projector.

[Space for Answers]

.....

.....

.....

XVIII References/Suggestions for further reading: include websites/links/Virtual lab Link

1. <https://youtu.be/d0GViR3exik?si=A0d9prtPRR0TLx8a>
2. <https://youtu.be/No0IOEJvvGA?si=wXMmEZwvmW9HgXfh>
3. https://www.mrright.in/ideas/home-security/cctv/how-to-install-a-cctv-camera- and-dvr-in-6-simple-steps/#google_vignette
4. <https://getsafeandsound.com/blog/cctv-camera-installation-materials-list/>

XIX Assessment Scheme

Performance Indicators		Weightage
Process Related (15 Marks)		60%
01	Identification of different blocks on trainer kit	10%
02	Connection made on kit	20%
03	Observation and Measurement taken	20%
04	Handling of equipment and Working in team	10%
Product Related (10 Marks)		40%
05	Interpretation of Results	15%
06	Conclusions	05%
07	Practical Related Questions	15%
08	Submission of Journal in time	05%
Total (25 Marks)		100 %

Marks Obtained			Dated Signature of Teacher
Process Related (15)	Product Related (10)	Total (25)	

Practical No. 28: Creating new interactive white board pages

I Practical Significance:

A digital whiteboard functions like a traditional whiteboard but is hosted virtually. Digital whiteboards can integrate with other video conferencing and screen sharing platforms to make collaboration possible even when everyone is not physically in the same room. A digital whiteboard offers multiple colors, shapes, and templates to choose from and can be saved as a shareable file for easy access in the future.

II Industry / Employer Expected outcome(s)

The aim of this practical is to attend the following industry/employer expected outcome through various teaching learning experiences.

Maintain various consumer electronic appliances/equipment.

III Course Level Learning outcome(s)

- Maintain various office automation appliances.

IV Laboratory Learning outcome(s)

- Create new white board pages using interactive whiteboard simulation software like Mimio studio, Smart learning suit online.

V Relevant Affective Domain related outcome(s)

1. Handle equipment carefully.
2. Follow safety precautions.

VI Relevant Theoretical Background.

An interactive online board is a digital platform that allows users to collaborate, communicate, and create content in real-time. These platforms typically offer a range of features designed to facilitate interactive and collaborative activities, such as:

Real-Time Collaboration: Users can work together on a shared virtual canvas, where they can draw, write, add images, and manipulate objects simultaneously, regardless of their physical location.

Multi-User Support: Interactive online boards enable multiple users to join the same session or workspace, making them ideal for group projects, brainstorming sessions, or virtual meetings.

Interactive Tools: They provide a variety of interactive tools and features, such as drawing tools, text boxes, sticky notes, shapes, and stamps, allowing users to express their ideas creatively.

Media Integration: Users can upload and integrate various types of media into the board, including images, videos, audio files, and documents, to enhance presentations or discussions.

1. **Chat and Communication:** Interactive online boards often include built-in chat or messaging features, enabling users to communicate with each other in real-time, share feedback, or ask questions.
2. **Remote Accessibility:** Since interactive online boards are web-based, users can access them from any device with an internet connection, making them convenient for remote work, online collaboration, or distance learning.
3. **Customization Options:** Users can customize the appearance and layout of the board according to their preferences, adjusting settings such as background color, gridlines, and zoom level.
4. **Integration with Other Tools:** Many interactive online boards offer integrations with other productivity tools and platforms, such as Google Drive, Microsoft Office, or project management software, allowing for seamless workflow integration.

Examples of popular interactive online board platforms include Miro, MURAL, Jamboard, Microsoft Whiteboard. These platforms are used in various contexts, including education, business, design, and project management, to facilitate collaboration, ideation, and visual communication.

VII Actual Circuit diagram used in a laboratory with related equipment rating.

a. Online white board diagram for a laboratory experiment.

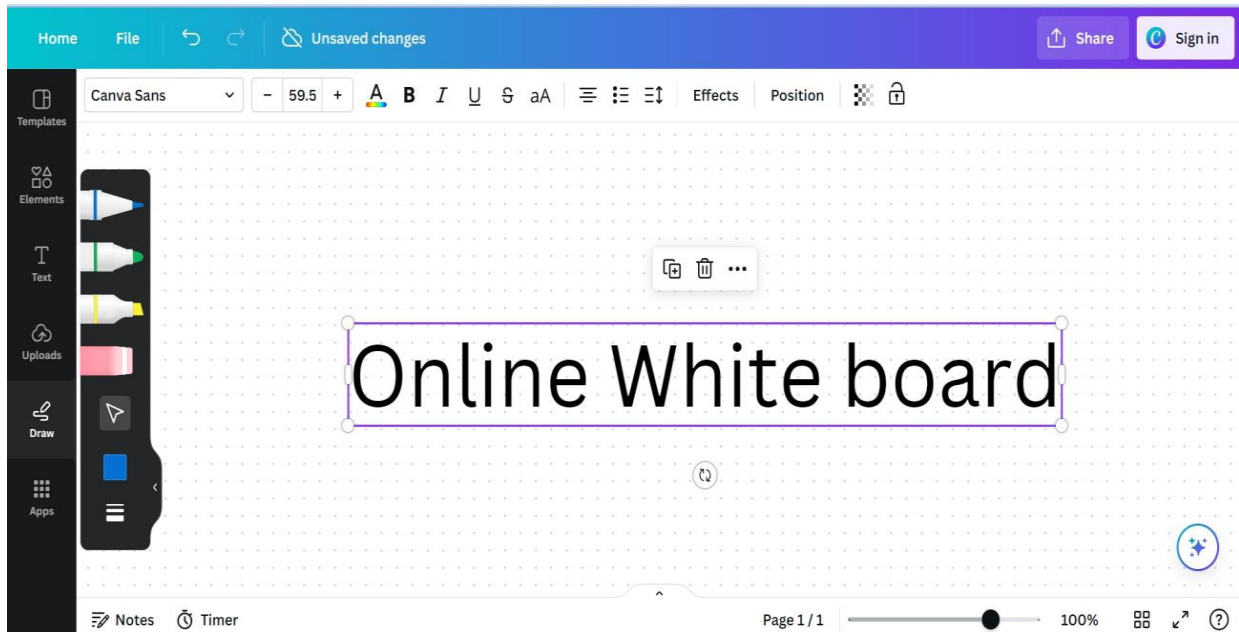

Figure 28.1. Online white board

b. Diagram for Actual online white board used in a laboratory. (Students can attach/paste printout of Online white board)**VIII Required Resources/apparatus/equipment with specifications:**

Sr. No.	Instruments/Components	Specifications	Quantity
01	Personal Computer	PC with Windows 10	01
02	Internet Connection	2 MBPS wifi connection	-

IX Precautions to be followed (Safety instructions / Rules / Standards)

- 1 Switch on Personal computer after proper connection of power supply.

X Procedure:

1. Test the wires/cables/Electronic Components used for connections properly. If they are faulty then keep it in the proper E-waste bin.
2. Connect PC to internet and Select an online whiteboard platform in google chrome. You can select any online white board such as Miro, MURAL, Jamboard, Microsoft Whiteboard.
3. Sign up for an account on the chosen platform if required, or simply log in if you already have an account.
4. Once logged in, you will typically have the option to start a new whiteboard session. Click on "New Board" or a similar option to create a new whiteboard.
5. Some platforms allow you to customize settings such as the background color, gridlines, or access permissions. Adjust these settings according to your preferences.
6. Depending on the platform, you will have different options for sharing the whiteboard with others. You may be able to generate a unique link to share, invite specific users via email, or collaborate with team members who are already part of the platform.

7. If you're collaborating with others, invite them to join the whiteboard session by sharing the link or sending invitations via email.
8. Select various tools and features available on the online whiteboard platform such as drawing tools, text boxes, shapes, sticky notes, media integration, and collaboration features as per your requirement.
9. Begin collaborating with your team or group by using the tools available on the whiteboard. You can draw, write, add images, upload documents, and manipulate objects in real-time.
10. Use built-in communication features such as chat or video conferencing (if available) to communicate with your collaborators as you work on the whiteboard.
11. Once you've completed your work or reached a stopping point, save your progress. Many online whiteboard platforms allow you to save your boards either automatically or manually. You may also have the option to export the board as an image, PDF, or other file formats for further use or sharing.
12. When you're finished using the online whiteboard, close the session or log out of the platform if necessary.

XI Required Resources

Sr. No.	Instruments/Components	Specifications	Quantity
1			
2			
3			
4			

XII Actual procedure followed

.....

.....

.....

.....

.....

.....

.....

.....

.....

.....

.....

.....

.....

.....

.....

.....

.....

.....
.....
XIII Observation table:

Sr. No	Function to be used	Instruction required to fulfill the given function
1	For New design/document	
2	To Write text	
3	To Draw circle	
4	To Erase data	
5	To Draw table	
6.	To Draw flowchart	

XIV Result(s):

.....
.....

XV Interpretation of Results:

.....
.....

XVI Conclusions and Recommendations:

.....
.....

XVIII References/Suggestions for further reading: include websites/links/Virtual lab Link

1. <https://www.canva.com/design/play?type=TAewJH6TtA8&category=tAEv8Hh5on0&locale=en>
2. <https://www.smarttech.com/en/lumio/why-lumio/how-lumio-works>
3. <http://mimio.hu/en-NA/Products/Interactive-Whiteboards.html>

XIX Assessment Scheme:

Performance Indicators		Weightage
Process Related (15 Marks)		60%
01	Identification of different blocks on trainer kit	10%
02	Connection made on kit	20%
03	Observation and Measurement taken	20%
04	Handling of equipment and Working in team	10%
Product Related (10 Marks)		40%
05	Interpretation of Results	15%
06	Conclusions	05%
07	Practical Related Questions	15%
08	Submission of Journal in time	05%
Total (25 Marks)		100 %

Marks Obtained			Dated Signature of Teacher
Process Related (15)	Product Related (10)	Total (25)	

Practical No. 29: Assess the quality of video conferencing session.

I Practical Significance:

Assessing the quality of a video conferencing session involves considering factors such as video and audio quality, connection stability, user interface, compatibility, security, engagement, and technical support. By evaluating these aspects, you can determine the effectiveness of the video conferencing platform and identify areas for improvement.

II Industry / Employer Expected outcome(s)

The aim of this practical is to attend the following industry/employer expected outcome through various teaching learning experiences.

Maintain various consumer electronic appliances/equipment.

III Course Level Learning outcome(s)

- Maintain various office automation appliances.

IV Laboratory Learning outcome(s)

- Test the audio video setting for video conferencing session

V Relevant Affective Domain related outcome(s)

1. Handle equipment carefully.
2. Follow safety precautions.

VI Relevant Theoretical Background.

Videoconferencing is becoming more popular, developing to advanced forms (such as telepresence), and being offered by various service providers both as a free or a premium service. Videoconferencing is being used in a variety of fields ranging from private consumer applications to more advanced purposes, such as business, education, and health-care related applications. Despite the rapid advancements of communication technologies, different factors such as the transmission techniques, hardware, the information coding systems, and the users' viewing condition can have high impact on the perceived quality of the transmitted audiovisual content and the overall communication quality.

Assessing the quality of a video conferencing session involves evaluating several key aspects:

1. **Connection Stability:** A good session should have a stable connection without frequent interruptions or dropouts. Assess if there were any instances of frozen screens, lagging audio, or disconnections.
2. **Video Quality:** Look for clear, sharp video resolution with minimal pixilation or blurring. Factors such as camera quality, internet bandwidth, and platform capabilities contribute to video quality.

3. **Audio Clarity:** Clear and consistent audio is essential for effective communication. Evaluate if participants' voices were clear without distortion or background noise interference.
4. **Platform Functionality:** Assess the ease of use and reliability of the video conferencing platform. Consider features such as screen sharing, chat functionality, and participant management tools.
5. **User Experience:** Evaluate the overall user experience, including ease of joining the session, navigation within the interface, and any technical issues encountered.
6. **Engagement and Interaction:** Consider the level of engagement and interaction among participants. A good session fosters active participation, collaboration, and effective communication.
7. **Content Sharing:** Evaluate the ability to share presentations, documents, or other multimedia content seamlessly during the session.
8. **Security and Privacy:** Ensure that the video conferencing platform prioritizes security measures to protect sensitive information and maintains user privacy.

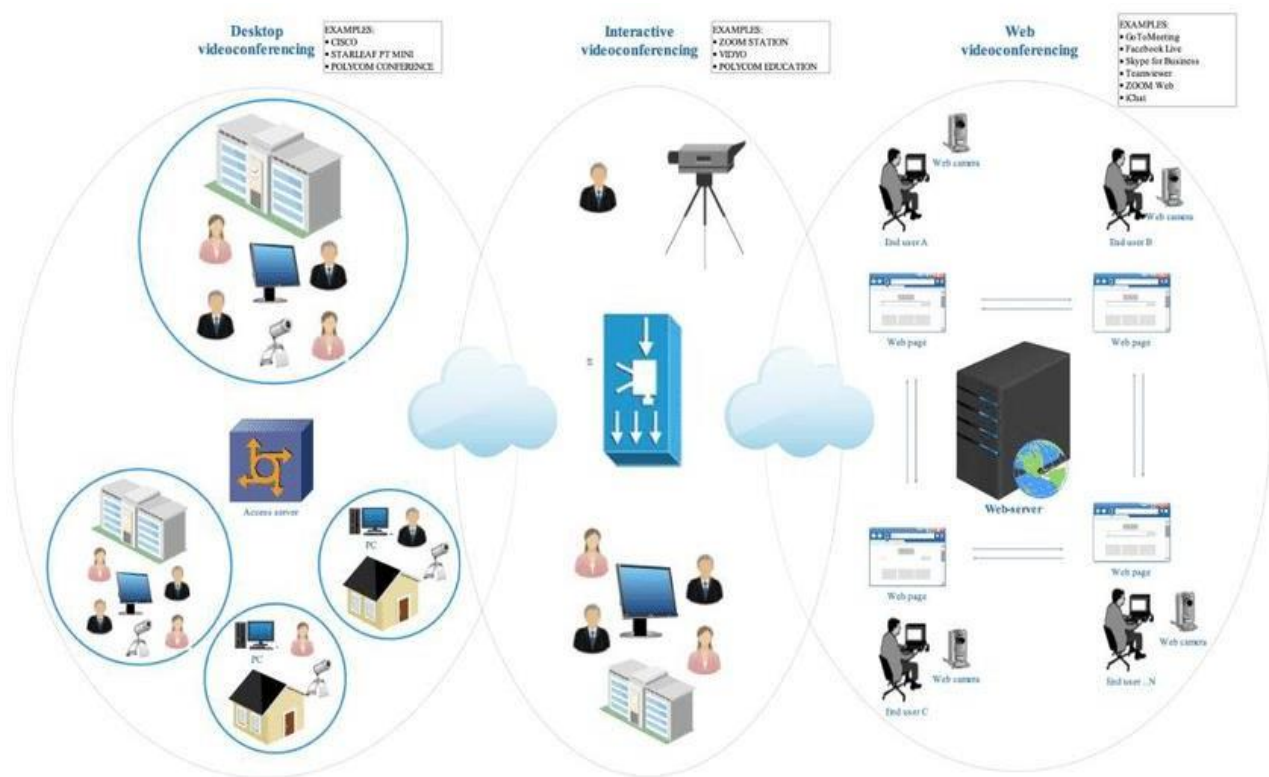

Figure 29.1: Visual illustration of video conferencing

VII Circuit diagram used in a laboratory with related equipment rating.

a. Suggested Video Conferencing diagram

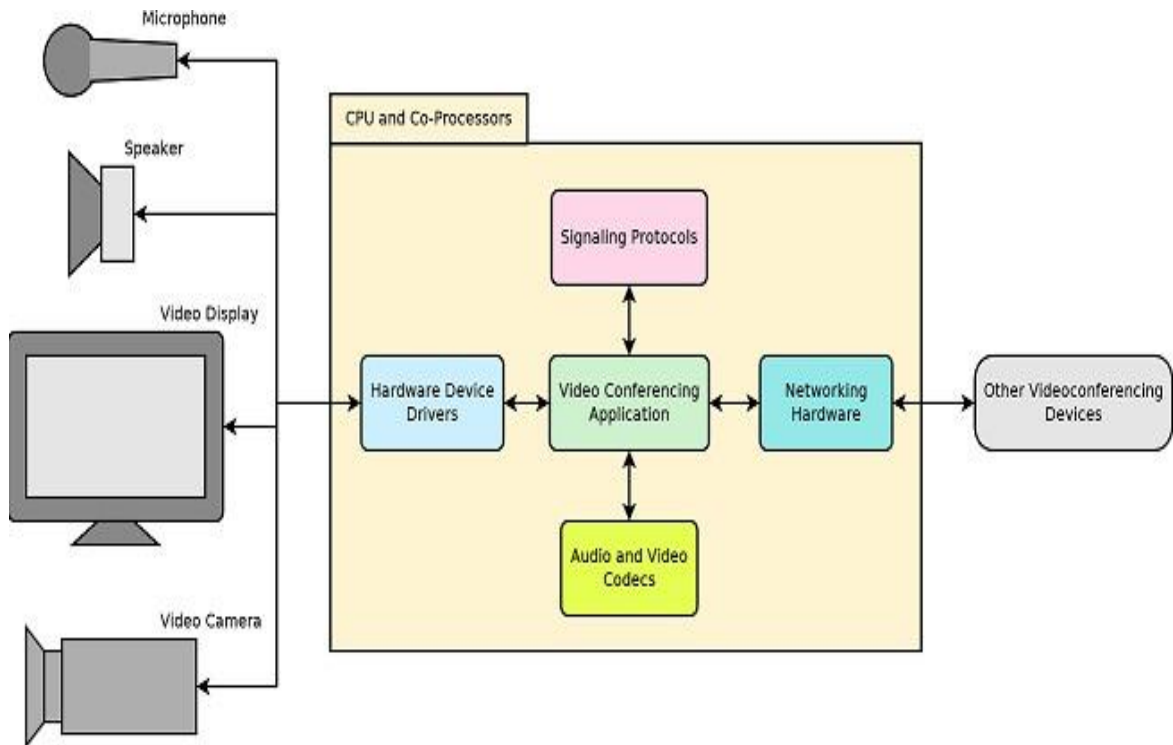

Figure 29.2: Block diagram of video conferencing room

b. Actual Circuit diagram/Kit used in a laboratory.

VIII Required Resources/apparatus/equipment with specifications:

Sr. No.	Instruments/Components	Specifications	Quantity
01	Desktop or PC with video conferencing platform such as Zoom, Microsoft Teams, or Google Meet with camera, microphone and speaker and high speed internet	PC with Windows 10	01

IX Precautions to be followed (Safety instructions / Rules / Standards)

- 1 Switch on Personal computer after proper connection of power supply.

X Procedure:

1. Test the wires/cables/Electronic Components used for connections properly. If they are faulty then keep it in the proper E-waste bin.
2. To assess the quality of video conferencing, procedure is divided into three main sessions:
 1. Preparation and joining the session.
 2. During the session.
 3. Post session.

1. Preparation and joining the session.

1. Ensure that all hardware components such as cameras, microphones, speakers, and internet connectivity are functioning properly.
2. Make sure the video conferencing software (e.g., Zoom, Microsoft Teams, Google Meet) is updated to the latest version and configured correctly.
3. Create a link through Zoom or google meet for video conferencing and share it to the people who are going to join the session.
4. Before joining, assess your internet connection speed using tools like Speedtest.net to ensure it meets the minimum requirements for video conferencing (usually around 1 Mbps upload/download for standard definition video).
5. Verify that your microphone and camera are working properly before starting the video conference.
6. Start your video conferencing session.

2. During the session.

1. Evaluate the video resolution and frame rate. Look for clarity, sharpness, and smoothness of video motion.
2. Assess the clarity and volume of audio. Check for any echo, background noise, or interruptions. Poor audio quality can significantly impact communication.
3. Note the delay between speaking and hearing others' responses (audio latency) and any delay in video transmission (video latency). Low latency is crucial for real-time communication.
4. Evaluate the ease of use and intuitiveness of the video conferencing platform's interface.

Consider factors like navigating between screens, accessing features like screen sharing or chat, and managing participants.

5. Test specific features such as screen sharing, recording, virtual backgrounds, and chat functions to ensure they work as expected without glitches.
6. Gather feedback from participants about their experience during the session. Ask about audio/video quality, ease of interaction, and any technical issues encountered.
7. Assess how engaged participants are during the session. Factors like attentiveness, active participation in discussions, and overall communication flow can indicate the effectiveness of the session.

3. Post session.

1. If the session was recorded, review the recording to assess the quality from an observer's perspective. Note any issues that may not have been apparent during the live session.
2. Analyze feedback collected from participants to identify recurring issues or areas for improvement.
3. Document any technical issues encountered during the session, including their impact on the user experience and potential causes.

XI Required Resources

Sr. No.	Instruments/Components	Specifications	Quantity
1			
2			
3			
4			

XII Actual procedure followed

.....

.....

.....

.....

.....

.....

.....

.....

.....

.....

.....

XIII Observation table:

- 1 Internet speed at your laboratory: _____Mbps
- 2 Video conferencing Software available at your laboratory: _____

Sr. No.	Parameters to be observed	Observations	Actions needs to improve quality
1	Internet speed		
2	Quality of video		
3	Quality of sound		
4	Availability of Screen sharing during session		
5	Availability of Chats during session		
6	Availability of managing participants during session		
7	Recordings of the video conferencing		

XIV Result(s):

.....

XV Interpretation of Results:

.....

XVI Conclusions and Recommendations:

.....

XVIII References/Suggestions for further reading: include websites/links/Virtual lab Link

- 1 <https://vocal.com/wp-content/uploads/2022/04/Video-Conferencing-Device.png>
- 2 <https://in.images.search.yahoo.com/search/images>
- 3 <https://youtu.be/GEvnanpHx5g?si=6arhmT0FnMGxi1XZ>

XIX Assessment Scheme:

Performance Indicators		Weightage
Process Related (15 Marks)		60%
01	Identification of different blocks on trainer kit	10%
02	Connection made on kit	20%
03	Observation and Measurement taken	20%
04	Handling of equipment and Working in team	10%
Product Related (10 Marks)		40%
05	Interpretation of Results	15%
06	Conclusions	05%
07	Practical Related Questions	15%
08	Submission of Journal in time	05%
Total (25 Marks)		100 %

Marks Obtained			Dated Signature of Teacher
Process Related (15)	Product Related (10)	Total (25)	

Practical No. 30: Determination of speed and capacity of shredding machine.

I Practical Significance:

A paper shredding machine is a mechanical device designed to destroy paper documents into smaller pieces, primarily for the purpose of maintaining confidentiality, data security, and preventing identity theft. Determining the speed and capacity of a shredding machine is essential for optimizing operational efficiency, productivity, resource planning, cost management, output quality, environmental impact, and ensuring safety and maintenance compliance. These factors collectively contribute to the effective utilization of shredding technology across various industries and applications.

II Industry / Employer Expected outcome(s)

The aim of this practical is to attend the following industry/employer expected outcome through various teaching learning experiences.

Maintain various consumer electronic appliances/equipment.

III Course Level Learning outcome(s)

- Maintain various office automation appliances.

IV Laboratory Learning outcome(s)

- Determine the shredding capacity and speed of a paper shredding machine.

V Relevant Affective Domain related outcome(s)

1. Handle equipment carefully.
2. Follow safety precautions.

VI Relevant Theoretical Background.

Paper shredding machines play a crucial role in maintaining information security and privacy in various settings, from homes and offices to large organizations and document destruction services. Understanding their components, types, and operational considerations helps users choose the right shredder for their specific needs while ensuring efficient and secure document destruction

Components of a Paper Shredding Machine:

1. **Feed Slot:** This is where documents are inserted into the shredder for destruction. It may include features like auto-feed for convenience.
2. **Cutting Mechanism:** The cutting mechanism varies based on the type of shredder:
 - **Strip-cut:** Cuts documents into long strips.
 - **Cross-cut:** Cuts documents into small particles, enhancing security compared to strip-cut.
 - **Micro-cut:** Shreds documents into tiny pieces, providing the highest level of security.

Blades or cutting elements are typically made from hardened steel to effectively cut through paper.

3. **Motor and Drive System:** Powers the cutting mechanism to shred paper efficiently. It needs to be robust enough to handle continuous shredding and prevent overheating.
4. **Waste Bin:** Collects shredded paper particles. The size of the waste bin varies depending on the shredder's capacity and intended use (home, office, industrial).
5. **Safety Features:** Include sensors that detect paper jams or overheating, automatically shutting down the shredder to prevent damage.
6. **Control Panel:** Contains buttons or switches for powering the shredder on/off, reversing the shredding direction to clear jams, and sometimes selecting different shred sizes.
7. **Overload Protection:** Prevents the motor from overheating due to excessive use or attempting to shred beyond its capacity.

Types of Paper Shredders:

- **Personal Shredders:** Designed for light use in homes or small offices, typically strip-cut or cross-cut.
- **Office Shredders:** Higher capacity than personal shredders, often cross-cut or micro-cut, suitable for medium to heavy use in offices.
- **Industrial Shredders:** Heavy-duty machines capable of shredding large volumes of paper continuously, often used in large offices or document destruction services.

VII Circuit diagram used in a laboratory with related equipment rating.

a. Suggested Circuit diagram/Kit



Figure 30.1: Shredder machine diagram

b. Actual Circuit diagram/Kit used in a laboratory.**VIII Required Resources/apparatus/equipment with specifications:**

Sr. No.	Instruments/Components	Specifications	Quantity
01	Paper shredding machine	Any suitable shredder machine	01
02	Sample Papers for shredding	Rough papers for shredding	10

IX Precautions to be followed (Safety instructions / Rules / Standards)

1. Do not switch on the power supply unless you have checked the supply connection.

X Procedure:

1. Test the wires/cables/Electronic Components used for connections properly. If they are faulty then keep it in the proper E-waste bin.
2. Switch on the machine and select shredder mode.
3. Insert sample papers to be shredded in the machine
4. Measure time required to cut single paper.
5. Count the number of papers that can be shredded at a time in the machine.

XI Required Resources

Sr. No.	Instruments/Components	Specifications	Quantity
1			
2			
3			
4			

XII Actual procedure followed

.....
.....
.....
.....

XIII Observation table:

Sr. No.	Parameter	Observations
1	Count of Total number of papers that can be inserted at a time in the in machine.	
2	Time required to cut single paper in Seconds	

IV Result(s):

.....
.....

XV Interpretation of Results:

.....
.....

XVI. Conclusions and Recommendations:

.....
.....
.....

XVII Practical Related Questions:

Note: Below given are few sample questions. Teachers must design such questions to ensure achievement of identified CO.

- 1 List the types of materials that can be used in a shredder machine for shredding?
- 2 Which type of cut does the shredder produce at your laboratory? (strip-cut, cross-cut, micro-cut)?
- 3 Does the shredder have anti-jamming features?
- 4 Write application of shredder machine.

XVIII References/Suggestions for further reading: include websites/links/Virtual lab Link

1. Ankit, B. R, Vinayak.D.W and Bhushan. G.P., “ Design and Fabrication of Paper Shredder.
2. https://cdn.shopify.com/s/files/1/1098/8162/articles/shredder_machine_1024x1024.jpg?v=1512407737

XIX Assessment Scheme:

Performance Indicators		Weightage
Process Related (15 Marks)		60%
01	Identification of different blocks on trainer kit	10%
02	Connection made on kit	20%
03	Observation and Measurement taken	20%
04	Handling of equipment and Working in team	10%
Product Related (10 Marks)		40%
05	Interpretation of Results	15%
06	Conclusions	05%
07	Practical Related Questions	15%
08	Submission of Journal in time	05%
Total (25 Marks)		100 %

Marks Obtained			Dated Signature of Teacher
Process Related (15)	Product Related (10)	Total (25)	