

Mission Success
Ensign-Bickford Aerospace & Defense Company (EBAD) is dedicated to supporting our customers in the aerospace and defense industry through on-time delivery of innovative products that exceed expectations and assure mission success.

NEA® Model 9040 Miniature

EBAD™ is the global leader in non-pyrotechnic Hold Down & Release Mechanisms (HDRM) for the spacecraft market. HDRMs are offered in a range of sizes. The NEA® Model 9040 supports release loads up to 1,100 N (250 lbf).

Principle of Operation

The NEA® HDRM is an electrically initiated, one-shot release mechanism that can carry a preload until commanded to release. The preload is applied through a release rod held in place by two separable spool halves, which are in turn held together by tight winding of restraining wire. The restraint wire is held in place by the electrical fuse wire. When sufficient electrical current is applied, the restraint wire unwinds, allowing the spool halves to separate, releasing the release rod and the associated preload.

NEA® Model 9040 Miniature Hold Down & Release Mechanism (HDRM)

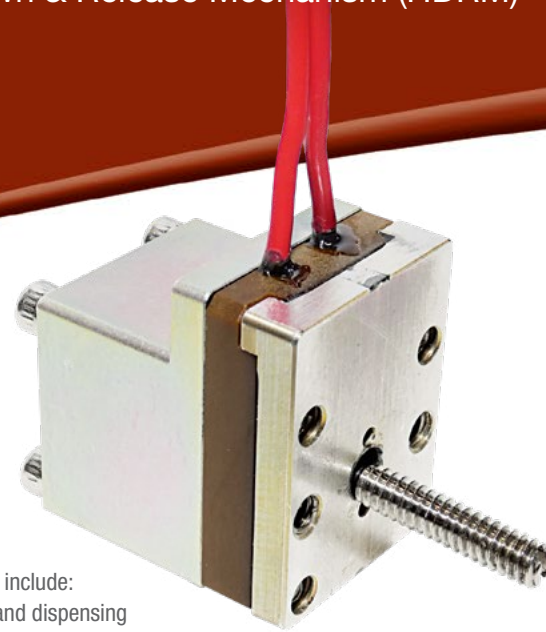

Applications

- Typical applications include:
- CubeSat release and dispensing
 - Scientific instruments
 - Satellite, Spacecraft, and Payloads

Key Features

- Low cost
- Low mass
- Extremely low release shock
- Single circuit activation (not redundant)
- One-time use

NEA® Model 9040 Miniature Hold Down & Release Mechanism (HDRM)

NEA® Model 9040 Miniature Technical Specifications

Parameter	Capability
Proof Load Rating	300 lbf (1,300 N)
Release Load Rating	250 lbf (1,100 N)
Output Shock @ Preload¹	<300 g's @ 250 lbf (1,112 N)
Fuse Wire Resistance	0.8 - 1.8 Ω
Actuation Current²	3.0 Amps for 50 ms
No-Fire Current³ (continuity)	250 mA
Release Time⁴	<50 ms
Temperature Range⁵	-60°C to 125°C
Maximum Angular Misalignment	3° Cone
Mass⁶	<25 g (.055 lbf)

Notes:

- ¹ Shock is preload & setup dependent, contact applications engineering for shock at other preloads.
- ² Actuation can be achieved using a range of current, the value in the table is the value for qualifying this device.
- ³ No fire current for 5 minutes or less at ambient temperature, consult EBAD applications engineers for other no-fire current requirements.
- ⁴ Release time is dependent on actuation current, preload, and temperature. Contact applications engineering for more specific information on actuation time as a function of current.
- ⁵ The values presented for qualification temperature range are not a measure of the limits of the device.
- ⁶ Includes mass of 24" lead wire.

NEA® Model 9040 Miniature Mechanical Interface Drawing

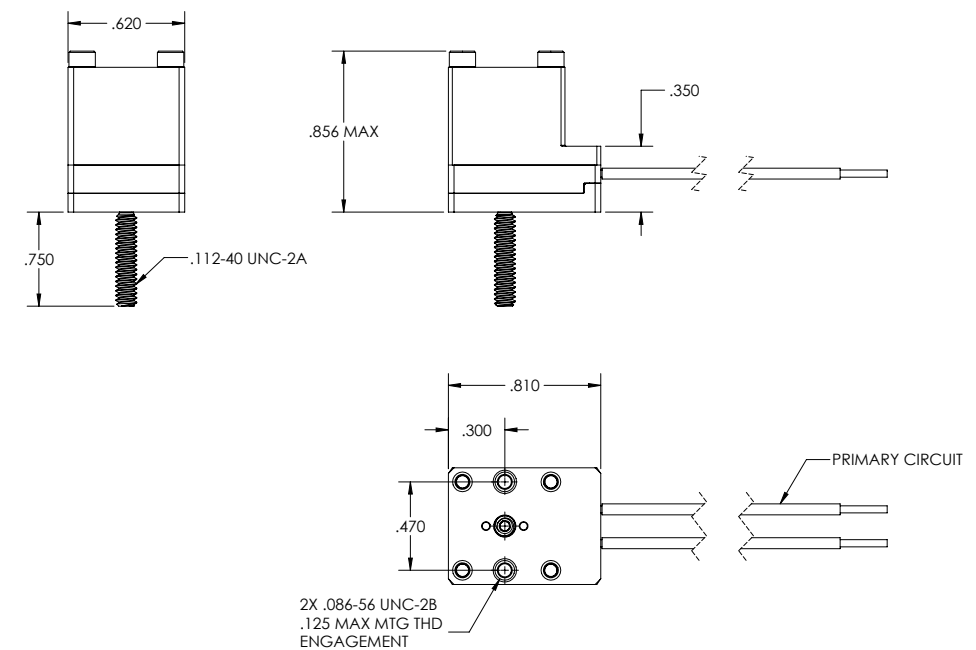

ENSIGN-BICKFORD AEROSPACE & DEFENSE COMPANY
640 HOPMEADOW STREET, P.O. BOX 429, SIMSBURY, CT 06070, USA www.EBAD.com

NEA® is a registered trademark of NEA Electronics, Inc. This product and its components are protected under U.S. Patent Numbers 6,433,990 / 6,249,063 as well as France Patent Numbers 125567 / 9903335, U.K. Patent Number 1255675 and Germany Patent Number 6011923.1.

Attention: The information and recommendations described in this brochure cannot possibly cover every application of the products or variation of conditions under which the products are used. The recommendations here in are based on the manufacturer's experience, research and testing. They are believed to be accurate, but no warranties are made, express or implied. In addition, the specifications contained herein are all nominal which represent our current production. The products described may be subject to change. Please feel free to contact Ensign-Bickford Aerospace & Defense Company for verification. No Warranties or Liabilities: THE PRODUCTS DESCRIBED HEREIN are sold "AS IS" and without any warranty or guaranty, express, or implied, arising by law or otherwise including without limitation any warranty of merchantability or fitness for a particular purpose. Buyer and user agree further to release and discharge seller from any and all liabilities whatsoever arising out of the purchase or use of any product described herein whether or not such liability is occasioned by seller's negligence or based upon strict products liability or upon principles of indemnity or contribution. Content©2022 Ensign-Bickford Aerospace & Defense Company, Simsbury, CT 06070, U.S.A.