

ALEV200 Series DC Contactor Specification 200Amps / 900VDC



Features

HIGH CURRENT AND HIGH VOLTAGE

Contact chamber is filed with inert gas to minimize arcing, up to 900VDC load is available.

COMPACT STRUCTURE, LOW NOISE

Contact design yields reduced unit size, low noise while carrying or switching current.

HIGH SAFETY

There is no arc leakage due to tight sealing.

HIGH CONTACT RELIABILITY

Stable contact resistance no matter how harsh the environment with sealed contacts

NO SPECIAL MOUNTING REQUIREMENT

Light weight actuator is less impacted by gravity with no special mounting orientation requirements.

EU ROHS DIRECTIVE (2011/65/EU) COMPLIANT



Nomenclature

Example

ALEV200

C

T

Series code:

"ALEV200" = ALEV200 Series

Coil Voltage Code:

"B" = 12VDC

"C" = 24VDC

"E" = 48VDC

"F" = 72VDC

Options (applied in this order):

Blank = Std. Options (Bottom Mount, Coil Wires, Without Aux. Contact & Polarized Load Terminals)

"A" = With Aux. Contact (SPST-NO)

"S" = Side Mount Version

"T" = Threaded Coil Terminal (not available with Aux contact)

ALEV200 Series DC Contactor Specification 200Amps / 900VDC



Performance Data

MAIN CONTACT		LIFE		
Contact Arrangement	1 Form X (SPST-NO, DM)	200A @ 450VDC	5000 Cycles	
Operating Voltage	12-900vdc	Mechanical Life	200,000 Cycles	
Rated Current	200A	AUX. CONTACT		
Maximum short circuit current	2,000A@320vdc 1 cycle	Aux. Contact arrangement	1 Form A	
Withstand Voltage *1	Between open contacts: 4,000 VDC, ≤ 1mA Between contact and coil: 2,500VAC, ≤ 1mA	Aux. Contact Current Max	2A@30VDC/ 3A@125VAC	
Insulation Resistance*1	Terminal to Terminal /Terminal to Coil New product: Minimum 100 MΩ @500vdc	Aux. Contact Current Min	100mA@8V	
		Aux. Contact Resistance	0.417 ohms @320VDC 0.150 ohms @125VAC	
Voltage Drop (@200A)	≤80mV			
ENVIRONMENTAL DATA		OPERATE / RELEASE TIME		
Shock, 11ms ½ Sine, Operating	20G Peak	Close (not including bounce)	30ms, Max. @20°C	
Vibration, Sine, Peak, 20G	80–2,000Hz	Release Time	12ms, Max. @20°C	
Operating Temperature	-40 to +85°C			
Weight	1.32 lb. (0.60 kg)			
COIL DATA				
Voltage Rating	12 Vdc	24 Vdc	48 Vdc	72 Vdc
Voltage (Max.)	15 Vdc	30 Vdc	60 Vdc	90 Vdc
Pick-up Voltage (20 °C)	9.0 Vdc	19.0 Vdc	38.0 Vdc	57.0 Vdc
Drop-out Voltage (20 °C)	0.5 - 4.0 Vdc	1.0 - 6.0 Vdc	3.0 - 10.0 Vdc	4.0 - 14.0 Vdc
Coil Current (20°C, Nominal Voltage)	1.1A	0.6A	0.3A	0.2A
Rated Coil Resistance±5% (20°C)	11 Ω	40 Ω	145 Ω	357 Ω

Note:

*1: Does not meet Dielectric & IR after test.

ALEV200 Series DC Contactor Specification 200Amps / 900VDC



Current Carry Curve

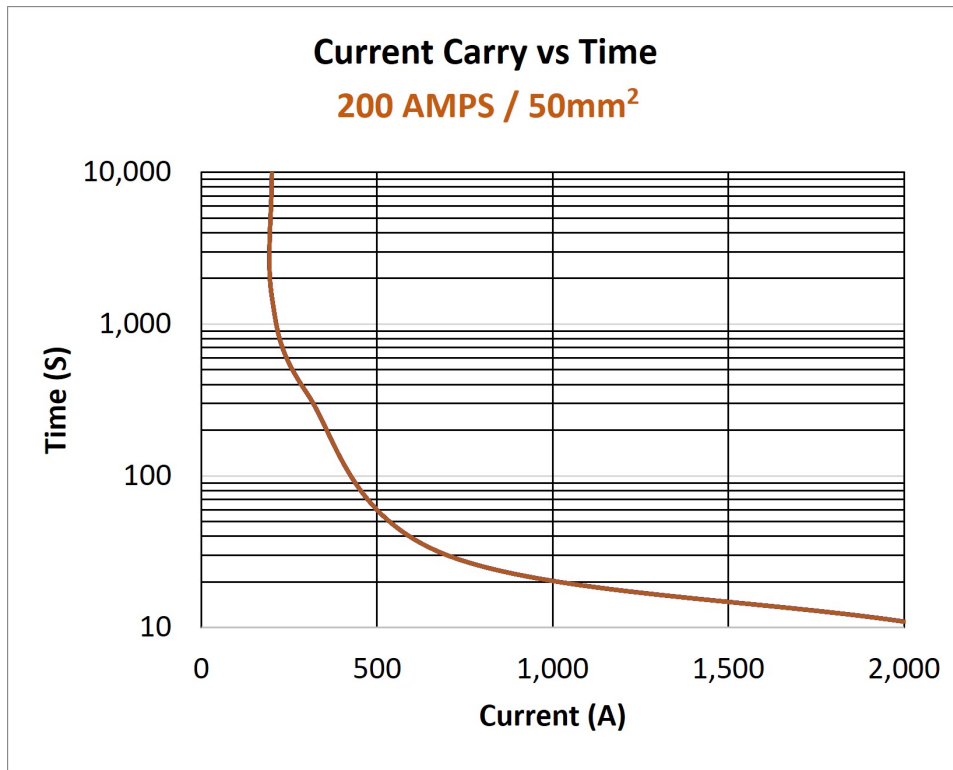

Note:

*When we using a higher conductor size,
the current will increase

ALEV200 Series DC Contactor Specification 200Amps / 900VDC



Outline Dimensions : inches (mm)

A. Bottom mount:

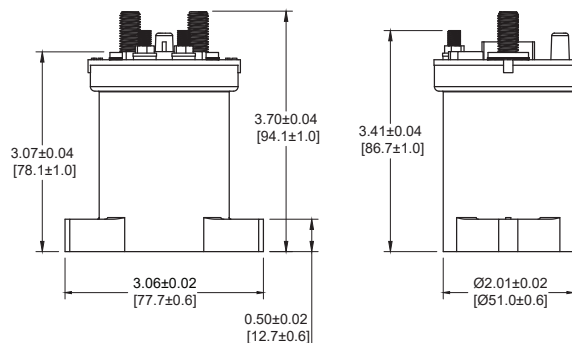
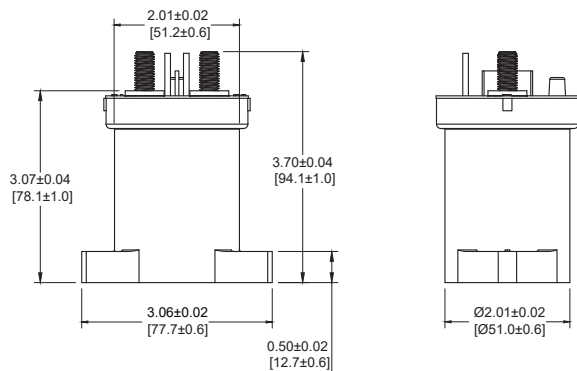
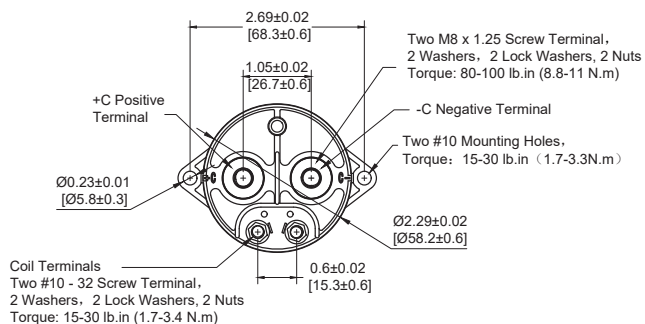
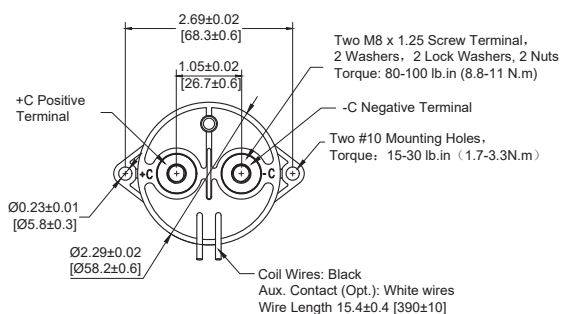

B. Side mount:

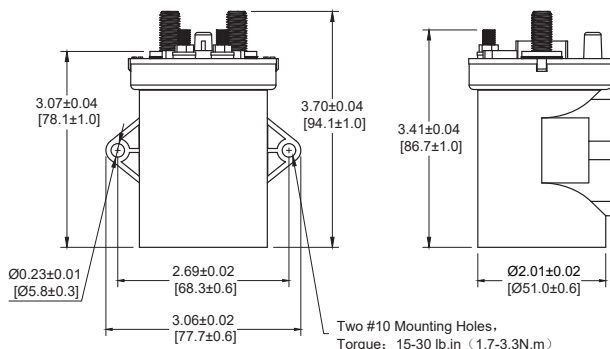
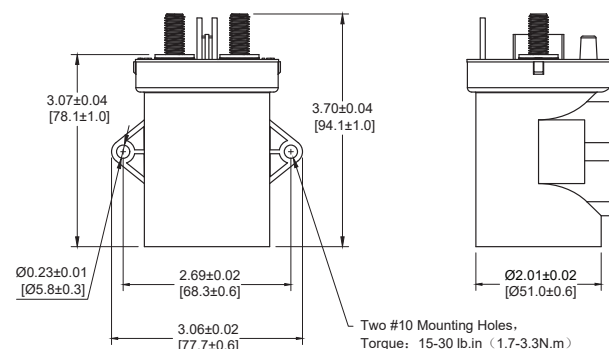
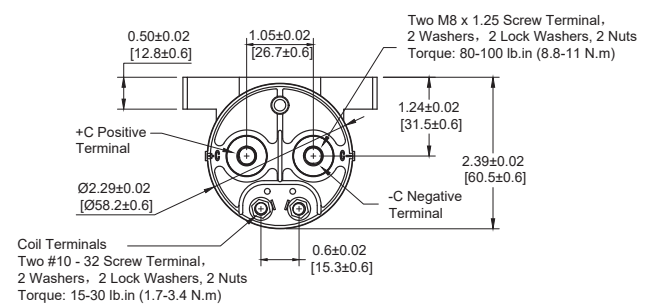
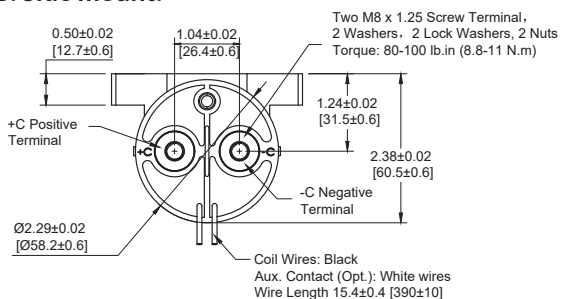

Note:

When stud terminals are specified for coil connections, the electrical connection is made at the base of the stud.

ALEV200 Series DC Contactor Specification 200Amps / 900VDC



Application Note:

1. Be sure to use washer to prevent screws from loosening, all the terminals or copper bar must be in direct contact with the contactor's terminals. Screw tightening torque is specified below. Exceeding the maximum torque can lead to product failure.
 - Contact torque (M8): 80 - 100 lb.in (8.8 - 11 N.m)
 - Mounting torque: 15 - 30 lb.in (1.7 - 3.3 N.m)
2. Contact terminals are polarized so refer to drawing during connecting. We suggest using a varistor rather than diode as a surge protector.
3. Do not use if dropped.
4. Avoid installing in a strong magnetic field (close to a transformer or magnet), or near a heat source.
5. Electrical life:
Use per load capability and life cycle limits so as not to cause a function failure (treat the contactor as a product with specified life and replace it when necessary). It is possible to make parts burn around the contactor once operating failure occurs. It is necessary to take layout into account and to make sure power shall be cut off within 1 second.
6. Lifetime of internal gas diffusion The contactor is sealed and filled with gas, lifetime of gas diffusion is determined by temperature in contact chamber (ambient temperature + temperature generated by contact operation). Operate only in an ambient temperature from -40 to +85 °C.
7. Drive power must be greater than coil power or it will reduce performance capability.
8. Avoid debris or oil contamination on the main terminals to optimize contact and avoid excess heat generation.
9. After continuous rated voltage / current has been applied to the coil and contacts, turning off the coil and immediately re-energizing the coil will result in a higher pick-up voltage than the rated value. This is due to increased coil resistance (coil temperature rise) of the device.