



# **AEQ FORUM IP**

**COMPACT DIGITAL AUDIO MIXER  
FOR BROADCAST APPLICATIONS**

## **USER'S MANUAL ED. 01/25**

V. 1.1 - 19/05/2025  
Software version 4.43, May 2025

## CONTENTS

<b>1. INTRODUCTION.....</b>	<b>5</b>
1.1. General description.....	5
1.2. Functional specifications.....	7
<b>2. PHYSICAL DESCRIPTION OF THE UNIT.....</b>	<b>9</b>
2.1. Description of the control surface.....	9
2.1.1. Channels.....	9
2.1.1.1. Routing keys.....	11
2.1.1.2. SELECT.....	11
2.1.1.3. Channel display.....	12
2.1.1.4. CUE.....	12
2.1.1.5. Indicators of active processes.....	13
2.1.1.6. ON AIR LED.....	13
2.1.1.7. Fader.....	13
2.1.1.8. Channel activation keys.....	14
2.1.2. Control and monitoring section.....	15
2.1.2.1. Control VU meters.....	16
2.1.2.2. Programmable keys.....	16
2.1.2.3. Main screen.....	17
2.1.2.4. Control room monitoring section.....	17
2.1.2.5. Studio room monitoring section.....	19
2.1.2.6. Talkback.....	20
2.1.3. Ventilation grille.....	20
2.1.4. Wrist-rest and side trims.....	21
2.2. Description of the rear panel and connections.....	22
2.2.1. Power supply.....	23
2.2.2. System common I/O's.....	24
2.2.2.1. GPIO.....	24
2.2.2.1.1. Opto-coupled GPI.....	25
2.2.2.1.2. Opto-coupled GPO.....	25
2.2.2.1.3. Physical contact GPO.....	26
2.2.2.2. Ethernet ports.....	27
2.2.2.3. Synchronism.....	28
2.2.2.4. Control and studio monitors.....	28
2.2.2.5. Control and studio headphones.....	29
2.2.2.6. Orders microphone.....	29
2.2.2.7. Optional MADI communications module.....	29
2.2.3. Audio inputs/outputs modules.....	30
2.2.3.1. FR02 Digital inputs/outputs module.....	31
2.2.3.2. FR03 / FR03S Mic/Line inputs module.....	33
2.2.3.3. FR04 Analogue line inputs module.....	34
2.2.3.4. FR05 Analogue line outputs module.....	35
2.2.3.5. FR14 AoIP module.....	36
2.2.3.6. FR22 USB inputs/outputs module.....	37
2.2.3.7. FR33 Telephone hybrid module.....	38
2.2.4. Wiring.....	38
<b>3. DESCRIPTION OF THE INTERNAL MENU.....</b>	<b>40</b>
3.1. "CLOCK" menu.....	40
3.2. "LOGIN/LOGOUT" menu.....	42
3.3. "MEMORY" menu.....	43
3.4. "MAIN MENU".....	44
3.4.1. "INFO" menu.....	45
3.4.2. "SETUP" menu.....	46
3.4.3. "SELECT" menu.....	47
3.4.3.1. "INPUT" menu.....	47
3.4.3.1.1. Dynamics menu: Compressor/Limiter and Noise Gate.....	49

3.4.3.1.2. Equalizer and filter menu.....	51
3.4.3.1.3. Expanded information menu.....	52
3.4.3.1.3.1. "CFG" menu.....	53
3.4.3.1.3.2. "FADER" menu.....	54
3.4.3.1.3.3. "ROUTE" menu.....	54
3.4.3.2. "OUTPUT" menu.....	55
<b>4. CONFIGURATION SOFTWARE.....</b>	<b>57</b>
4.1. "Administration" menu.....	60
4.1.1. "Configurations" submenu.....	60
4.1.1.1. Dante Configuration.....	64
4.1.2. "User Levels" submenu.....	69
4.1.3. "User Configuration" submenu.....	73
4.1.4. "About Forum IP Setup" submenu.....	75
4.2. "Hardware Configuration" menu.....	75
4.2.1. "Board Configuration" submenu.....	76
4.2.1.1. "Module Configuration" section.....	78
4.2.1.2. "Internal Module/Virtual - Configuration" section.....	79
4.2.2. "Mixer Bus Configuration" submenu.....	83
4.2.2.1. Configuration of MPX buses menu. "Clean Feed" mode.....	85
4.2.3. "I/O Configuration" submenu.....	90
4.2.3.1. Advanced configuration of input channels menu.....	91
4.2.3.2. Advanced configuration of output channels menu.....	95
4.2.4. "Monitoring Configuration" submenu.....	96
4.2.4.1. "Studio Room Section".....	97
4.2.4.2. "Control Room Section".....	97
4.2.5. "Visual Radio" submenu.....	98
4.2.6. "NTP Client Configuration" submenu.....	100
4.2.7. "Vumeters" submenu.....	101
4.2.8. "Options" submenu.....	102
4.3. "Programmable Configuration" menu.....	103
4.3.1. "Routing Configuration" submenu.....	103
4.3.2. "Programmable Keys" submenu.....	105
4.3.2.1. Basic configuration of programmable keys.....	106
4.3.2.2. Configuration of "General" programmable keys.....	107
4.3.2.3. Configuration of "Salvo" programmable keys.....	109
4.3.2.4. Configuration of "Codec" programmable keys.....	111
4.3.2.5. Configuration of "Multiplex" programmable keys.....	114
4.3.2.6. Configuration of "Cue Reset" programmable key.....	115
4.3.2.7. Configuration of "Orders" programmable keys.....	115
4.3.2.8. Configuration of "Memory" programmable keys.....	116
4.3.2.9. Configuration of "Studio Monitor Attenuation" programmable keys.....	117
4.3.2.10. Configuration of "Auto Cue" programmable key.....	117
4.3.2.11. Configuration of "A/B Mode" programmable key.....	118
4.3.2.12. Configuration of "To Mixer Bus" programmable keys.....	118
4.3.2.13. Configuration of "Split CUE" programmable keys.....	119
4.3.2.14. Configuration of "Remote Production" programmable keys.....	119
4.3.3. "Mic Group Configuration" submenu.....	121
4.3.4. "Preset Configuration" submenu.....	123
4.3.4.1. Advanced configuration of Compressor/Limiter.....	125
4.3.4.2. Advanced configuration of Noise Gate.....	126
4.3.4.3. Advanced configuration of Equalizer.....	127
4.3.4.4. Advanced configuration of Low Pass Filter.....	128
4.3.4.5. Advanced configuration of High Pass Filter.....	128
4.3.5. "SnapShot Configuration" submenu.....	129
4.3.5.1. Advanced configuration of inputs.....	134
4.3.5.2. Advanced configuration of outputs.....	136
4.4. "Firmware Upgrade" menu.....	137
4.4.1. "Tree View" submenu.....	137
4.4.2. "Upgrade View" submenu.....	140

4.4.3. "Log View" submenu.....	141
<b>5. A.E.Q. GUARANTEE.....</b>	<b>142</b>
<b>APPENDIX A. SIGNALLING CONNECTION.....</b>	<b>143</b>
<b>APPENDIX B. ADDITIONAL INFORMATION.....</b>	<b>147</b>

## 1. INTRODUCTION.

### 1.1. General description.

**AEQ FORUM** and **AEQ GRAND FORUM** (and their editions **IP** and **V2**) are digital audio mixers for Broadcast applications, specifically designed for ON AIR applications and highly adaptable to different operational situations. They incorporate all the basic features needed in such environments: automatic monitors muting, cough muting, fader-start, signalling control, control signals for external equipment automation, management of external communications, intercoms, etc.

The modular design and reduced size make those mixers perfectly adaptable to many different scenarios: self-control, control-studio, audio control in television, sound production, mixed configurations, integration in large systems, etc.

One of the main qualities of both them is the extensive internal routing capacity which provides: up to 64 inputs/outputs for analogue, digital or microphone audio signals, and another 64 input/output multichannel audio over a MADI link (in order to activate this function, you must purchase a user license).



NOTE: The exterior of the equipment and some screens or displays may vary depending on version.

The power of control and simplicity are combined in **AEQ FORUM** to cover both basic and advanced operating needs, starting with a 4 faders control surface that can easily be expanded to 8 or 12 faders; in the case of **AEQ GRAND FORUM**, it can be expanded up to 16 or 20 faders.

All basic functions of activation, level adjustment and routing have their specific controls on each channel of the FORUM surface, while less common adjustments are included in a set of contextual controls common to all channels and accessible with just one or two keystrokes: simplicity and clarity of use for dynamic control without handling error.

The flexibility offered through the configuration of the system enables the free assignment of any audio input of the system to any control channel, and changing the distribution of signals from the surface itself or the associated configuration software.

The digital mixer includes memory banks that store the settings for each signal: control surface signal distribution, routing to the output buses, management of parameters and activation of the different available audio processes. This allows the console to adapt easily to different programs with different technical requirements.

Its two Ethernet ports enable the local or remote interconnectivity, facilitating set-up and maintenance, monitoring and control.

Forum has also been designed to ensure interoperability with communications equipment and future developments by AEQ or other manufacturers.

There is also a version of the console, named **AEQ FORUM IP SPLIT**, where the control surface is separated from the "core" or "engine" (where all the audio inputs/outputs, routing, sum and processing electronics is included) and the control surface modules can be also installed separately (Split style). The interconnection of control surface and "core", as well as the control surface module, is made through standard shielded CAT5 cables (with RJ45 connectors). It's possible to install up to **24 fader channels**.

From a configuration and operational point of view, **AEQ FORUM IP SPLIT** console does not differ from the original self-contained version. The configuration software ("**Forum IP Setup**") and "FORUM Screen" and "FORUM Virtual" applications are supported by this version of the console.



The data and power supply output from console to control surface is located at the right of the power supply input of the "core". It is designed for use with straight Ethernet cabling, but also carries proprietary **power supply lines**. Please use the cable provided with the unit only. If necessary, this connection could be made by means of a cable of up to 250 meters, using a continuous **CAT5E shielded** (FTP) cable (or better) and checking that the **shield** is connected to the connectors case.

**IMPORTANT NOTE: Do not connect this output to any device but the control and monitoring module** (there is a severe risk of damage to other equipment or even the "core" itself). In order to avoid any damage to the unit is **VERY IMPORTANT** to turn off the unit before connecting or disconnecting this cable.

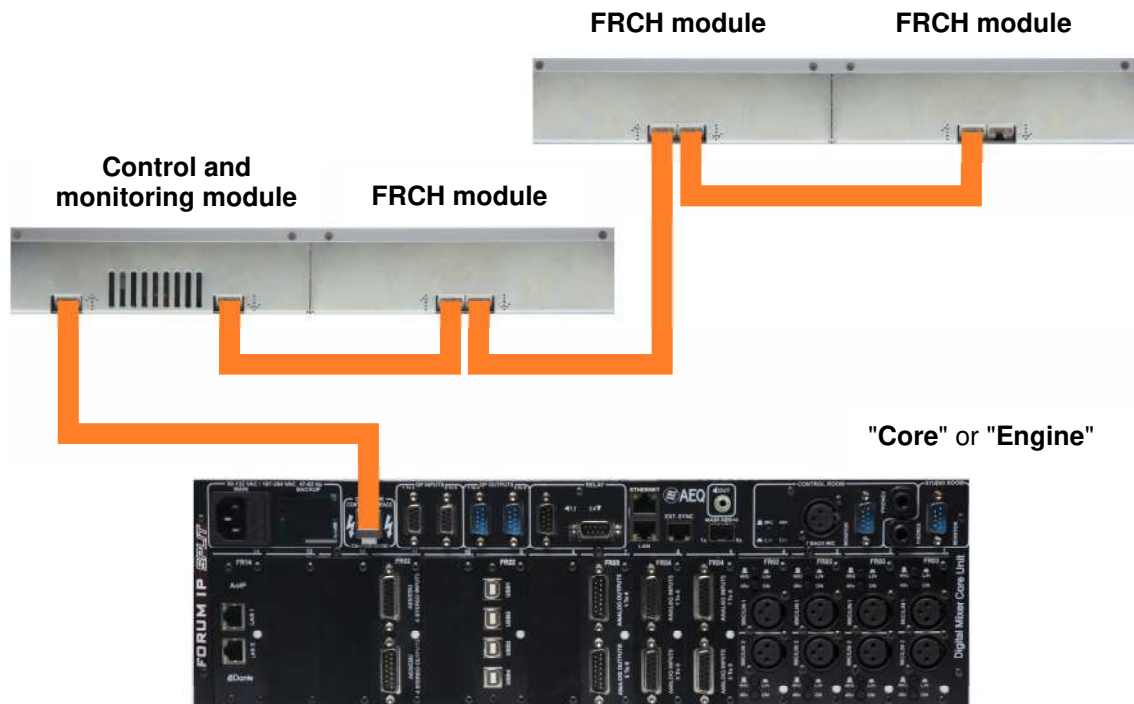

The example shows the connection diagram of **AEQ FORUM IP SPLIT** console. The data and power supply output from "core" must be **always** connected to the **left RJ45** connector of control and monitoring module (rear view). The first FRCH module is also connected by means of a straight Ethernet cable from the right RJ45 connector of control and monitoring module to the left RJ45 connector of FRCH module (rear view). In order to connect the following FRCH modules, straight Ethernet cables must be used from the right RJ45 connector of a FRCH module to the left RJ45 connector of the following FRCH module (rear view).

## 1.2. Functional specifications.

- Self-contained Design (except in the case of AEQ FORUM IP SPLIT).
- Configurable size of 4, 8 or 12 faders (up to 16 or 20 faders for AEQ GRAND FORUM and up to 24 faders for AEQ FORUM IP SPLIT). Conductive plastic faders 100mm.
- Internal sampling rate 48 KHz - 24 bits (96 KHz under request). Variable through external clock reference.
- Modular design that allows you to adjust the number of inputs and outputs of the equipment to the requirements of each facility. Front removable modules for easy maintenance.
  - Up to 14 modules of multiple inputs and outputs, out of which 4 can be double micro- line and 2 digital hybrids.
  - Electronically balanced microphone inputs with phantom power.
  - Electronically balanced analogue line Inputs and outputs. Adjustable gain  $\pm 12$ dB. Balance/panoramic control selectable for all channels. Selective phase inversion. Adjustable gain for up to 128 signals, including hidden signals.
  - Transformer balanced digital inputs and outputs with adjustable gain  $\pm 12$  dB. Balance/panoramic control selectable for all channels. Selective phase inversion. Adjustable gain for up to 128 signals, including hidden signals.
  - Sample rate converter (SRC) for all digital inputs. Supports AES/EBU and S-PDIF digital signal formats.

- Additional input, integrated talk-back and auto-control micro-line.
- Integrated monitor and headphone outputs for control and studio. Cough mute, ON-AIR signalling for studio and control, fader-start, remote PFL, talk-back, automatic monitors muting. Monitoring can be configured for any of the system signals.
- CUE output and integrated CUE speaker (no speaker in the case of AEQ FORUM IP SPLIT).
- Headphone outputs integrated into the chassis.
- PFL Monitor integrated in chassis (except in the case of AEQ FORUM IP SPLIT).
- Optional 64 channels digital MAD1 optical fiber connection (available by means of user license).
- Test tone (1KHz) generator.
- 8 Opto-coupled GPIs and GPOs and 4 relay contact GPOs.
- 4 direct routing buttons on each channel.
- Internal Routing 64x64 mono, with additional capability for routing signals from the optional MAD1 interface (available by means of user license).
- All signals assignable to any control channel.
- Configuration of up to 10 MPX internal buses.
- 2 precision stereo VU meters.
- Externally synchronized clock, timer and stopwatch.
- Control of external equipment (AEQ hybrids and audiocodecs) integrated in the programmable key section.
- Communication control via Ethernet 10/100 connection through TCP / IP protocol. For more information see chapter "4. CONFIGURATION SOFTWARE" of this manual.
- Memory banks for mixer snapshots or settings of all the available signals: up to 10 available memories.
- Processing of audio signals including system defaults to the basic configuration.
  - Audio processing capacity for up to 20 stereo signals (up to 12 in Fader and 8 hidden).
  - All audio processes are predefined but always allow manual adjustment in real time and associated non-volatile memory storage system.
  - Audio effects are available: parametric equalizer, high and low pass filters, compressor/limiter and noise gate.
- Noiseless natural convection. AEQ FORUM is particularly suitable for self-operation formats.
- Optional redundant power supply.

## 2. PHYSICAL DESCRIPTION OF THE UNIT.

AEQ FORUM is a self-contained (except in the case of AEQ FORUM IP SPLIT), compact digital mixing console, which means that its two functional blocks are housed in the same physical chassis. On one hand the control surface, where the controls and status indicators are located and on the other, the "audio engine" which contains all electronics for audio inputs and outputs as well as routing blocks, summing and processing.

Both functional blocks will be separately described below.

### 2.1. Description of the control surface.

Control surface is the operator's work area of the console. All the operational organization, management and implementation of the audio program is accomplished from this area. The control surface incorporates all the keys, screens, faders, encoders and VU meters required to easily operate the equipment.

There are two different areas on the control surface: the area that corresponds to the audio channels controlled through faders (each module includes 4 faders) and the "CONTROL AND MONITORING MODULE" which is normally located to the right.

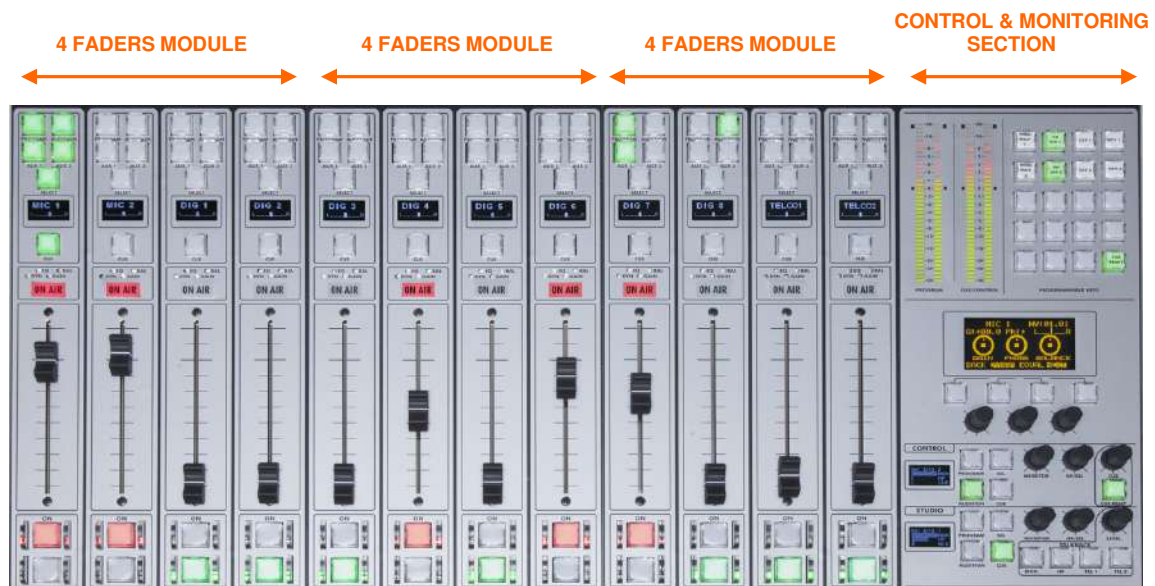

**NOTE:** From the firmware versions of MSC and FSC of January 2025, when "Screensaver" mode is active, a "soft" turn off function is added in order to reduce consumption and protect lifetime of displays and keys: when the control surface remains unused for an hour, all LEDs and keys that are on are turned off, the vumeters are turned off and the displays contrast is set to minimum (or turns off, depending on the series of the installed display). This turn off function can also be performed manually by keeping pressed for 5 seconds the first contextual key (the leftmost one) of the main screen. In this status, any action detected on the control surface makes it returns to its normal status. For more information, see section 4.2.8 of this manual.

#### 2.1.1. Channels.

The control surface is built on independent modules of 4 faders called "FRCH". The control surface capacity can be expanded from a basic configuration of 4 channel faders to 8 and up to **12 channel faders**. For **AEQ GRAND FORUM** it can be expanded up to **20 faders** and for **AEQ FORUM IP SPLIT** up to **24 faders**.

The assignment of signals to channel faders is completely user definable. It is possible to assign any signal to any channel fader at any time. This allows for the re-distribution channels to adapt to different programs or operators.

In addition, different channel assignment of signals can be stored in memory to be used by different users or applications.

In addition to the signals on channel faders present on the control surface that can be mixed, processed and sent to any output channel, the AEQ FORUM is capable of routing and adjusting the levels for other hidden signals up to 128x128 audio signals.



Located in the upper part of the channel are 4 routing keys ("PROGRAM", "AUDITION", "AUX1" and "AUX 2") and a "SELECT" button to assign the channel to advanced settings common control (gain, dynamics, EQ and balance). By means of a long press (more than 2 seconds), the "SELECT" key provides quick access to the signal selection on the fader.

Beneath this section, an OLED display shows channel name and status for balance or pan. Immediately under the display is located the Pre-listen button "CUE", 4 status indicators LEDs that alerts with regards to the activation of equalization ("EQ"), dynamics ("DYN"), balance ("BAL") and gain ("GAIN"). Also in this section, a luminous label indicating that the channel is activated and is sending signal to the output buses ("ON AIR").

By pressing the "SELECT" button the advanced configuration functions are enabled. These configurations are accomplished within the integrated multifunction display in the control and monitoring section at the far right of the control surface. Its operation is based on rotary encoders and graphical menus and short-cut function keys, depending on the information shown on screen.



Among the general functions are the instant activation and adjustment of audio effects (EQ, filters, limiters, etc.), configurations and memories management, disconnection of applied effects, phase change, inserting of a test signal, as well as clock, timer and stopwatch for timing control, etc. For more information see chapter "3. DESCRIPTION OF THE INTERNAL MENU" of this manual.

The Channel module is completed with plastic conductive sliding faders and the Channel ON and OFF buttons.

#### 2.1.1.1. Routing keys.

There are four keys on the top of the channel that routes the channel signal to the corresponding output bus. Activation is indicated through the integrated LEDs in each of these keys, and indicates the creation of a cross point between the input signal on the channel and the output channel corresponding to the key.



From left to right and top to bottom, the four keys of direct routing are "**PROGRAM**" (sending to master 1), "**AUDITION**" (sending to master 2), "**AUX1**" (sending to auxiliary 1) and "**AUX2**" (sending to auxiliary 2). The allocation of physical outputs associated with these signals and the physical circuits of the inputs/outputs modules on the back of AEQ FORUM is accomplished from the configuration software. For more information, please refer to chapter "4. CONFIGURATION SOFTWARE" of this manual.

#### 2.1.1.2. SELECT.

The control surface of AEQ FORUM offers the usual controls for a mixing console on each channel, but AEQ FORUM also offers a wide range of possibilities for routing and processing, beyond the physical options included in each channel. These possibilities have been distributed in a logical manner within internal menus accessible from the main screen of the Control and Monitoring section.

The operation is intuitive, always beginning with pressing the "SELECT" button on the channel that you want to process and moving to the main screen of the Control and Monitoring section of the console to accomplish the activations or adjustments. For further details please refer to section 3.4.3.1 of this manual.

By means of a long press (more than 2 seconds), the "SELECT" key provides quick access to the signal selection on the fader. See section 3.4.3.1.3.2 of this manual.

### 2.1.1.3. Channel display.

Each of the 12, 8 or 4 channels (depending on the AEQ FORUM configuration ordered) integrates a two-colour OLED display showing:

- Name of the associated audio signal (maximum 6 characters, editable via the configuration software). For more information see chapter "4. CONFIGURATION SOFTWARE" of this manual.
- Status of balance between left (L) and right signal (R) in stereo signals (or panoramic for monophonic signals).



**NOTE:** For firmware version 2.03 of FSC (or 1.14 for earlier editions of the board) or higher, the order of this information changes, with the signal name appearing below and the status of balance or panoramic above. In addition, when the surface enters low lighting mode (after remaining about 5 minutes without being used), a lateral scroll of that information starts in order to protect the lifetime of the displays (that scroll can be deactivated: see section 4.2.8 of this manual). Additionally, from the firmware versions of FSC of January 2025, a "soft" turn off function is added (for more information, see section 4.2.8 of this manual).

### 2.1.1.4. CUE.

This button allows you to activate a pre-fader listening to the audio channel for monitoring and control. When activated the integrated LED is lit. It is possible to send the audio signals of several channels to the CUE bus, acting as a summing bus. There is a type of programmable keys ("Auto Cue") that allows you to modify the working mode of these keys (see section 4.3.2.10 of this manual).

There is the option of setting one of the programmable keys on the Control and Monitoring section (C&M) as a general "CUE RESET" that disconnects all active signals from the CUE bus. In the case of **FORUM IP**, there is a specific key in the **control room monitoring section** that execute that function (although it's also possible to associate it simultaneously to a programmable key).

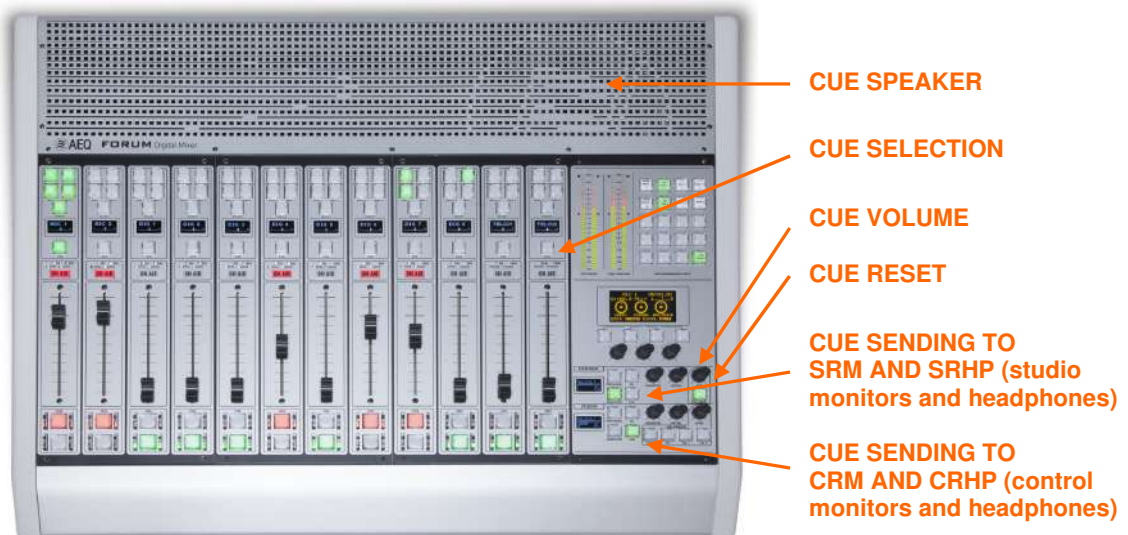

CUE signal associated controls

The CUE speaker is built-in in the upper right of the control surface, beneath the ventilation grille, and the volume control is through an encoder in the Control and Monitoring section of the control surface. In the case of AEQ FORUM IP SPLIT, there is CUE output but no built-in speaker.

### 2.1.1.5. Indicators of active processes.

Under the "CUE" button there are four LEDs with corresponding labels, from left to right and top to bottom, "EQ" (equalizer), "BAL" (balance), "DYN" (dynamic processor) and "GAIN". The lit status indicates the activation of any of the four processes previously mentioned in a certain fader channel.



These four processes (EQ, dynamics, balance and gain) are controlled from the internal menu associated with the "SELECT" button on the main screen of the Control and Monitoring section.

### 2.1.1.6. ON AIR LED.

Under the lights of active processes is located the "ON AIR" warning light. This light is ON when the audio signal present at the input of the channel is sent to any of the outputs previously described (see section 3.4.3.1.3.3 of this manual).

For this, two conditions must be met simultaneously:

- Channel fader is located in any position except at minimum of travel of the fader.
- Channel ON key is activated.



### 2.1.1.7. Fader.

100mm conductive plastic fader. The fader travel is printed with 11 bands, the last upper one corresponding to maximum gain (+12dB), and the third band from above to unity gain or nominal setting (+0dB). Both of these marks are differentiated in size from the rest.

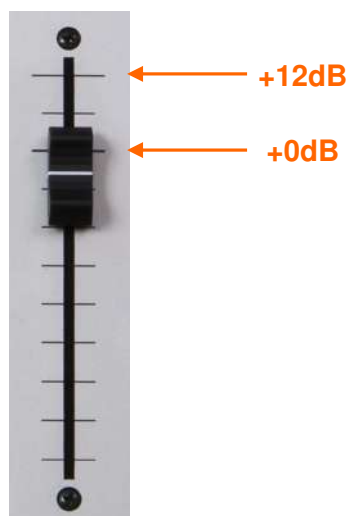

There is an option in the configuration software ("**Fader Mode**") that allows you to modify the position of that nominal operating setting (see section 4.2.1 of this manual).

The response mode of the fader is logarithmic, producing great attenuation of the level at the bottom of the fader travel and less adjustment at the top.

The bottom position of the fader travel, triggers gain  $-\infty$ dB or absence of signal, which is also reflected in the channel "ON AIR" indicator (it turns off).

#### 2.1.1.8. Channel activation keys.

The channel activation keys, "CHANNEL ON/OFF", enable or disable the sending of the audio signal present at the channel input to the outputs previously defined. If the sliding fader is located in any position of the fader travel other than the minimum, the channel on or off activation will be reflected through the "ON AIR" indicator previously described.

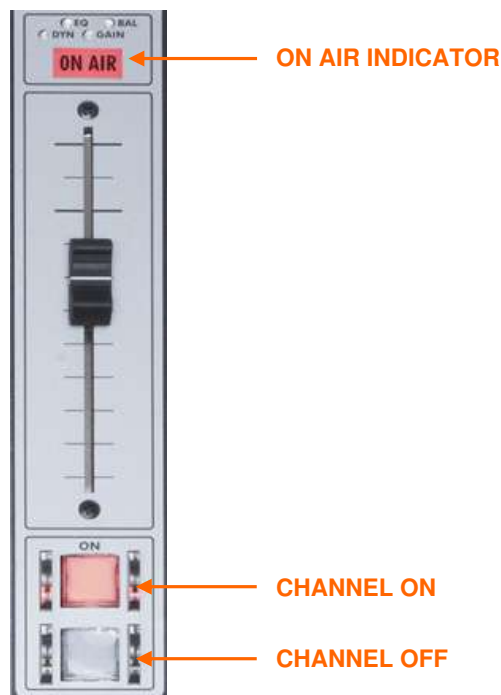

The **upper** key is associated with **ON** function and has a red light built in and the **lower** key is associated with **OFF** function and has a yellow light. The operation is exclusive, both keys can not be turned on simultaneously. This is the **NORMAL** working mode.

As indicated below in section 3.3, when a new configuration memory or snapshot is loaded, the audio of the activated channel or channels (ON AIR) will not be interrupted (and the associated routing will remain) provided that in the new memory those channels are placed in the same fader positions. When the option "**Snapshot: Blink when the signal has not been loaded**" is also activated in the configuration (see section 4.2.8 of this manual), the **upper activation key** of those activated channels will start blinking to indicate that they keep the previous configuration.

There are 3 additional working modes for the channel activation keys that can be activated in the corresponding configuration memory or snapshot. In these modes, the **upper** key is associated with **ON/OFF** function and the **lower** key works as follows:

- **ORDERS:** when you press and keep pressed the key you send the orders microphone to the output channel associated with the input present at the channel (Talkback functionality).
- **A/B:** if you press the key for more than 500 ms, when you release it a fast change of the input assigned to the channel is accomplished (it is shown in the channel display).

- **GPO:** when you press and keep pressed the key you activate the physical or virtual GPO output associated with the input present at the channel (the GPO is deactivated when you release the key).

For more information about these modes, see section 4.3.5 of this manual.

These keys can be activated remotely by GPI. To configure remote activation, see section 4.2.3.1 of this manual.

### 2.1.2. Control and monitoring section.

The control and monitoring section (C&M) of the control surface is usually located to the right. This section enables the overall management of the signals on the system, including routing and control processes, as well as monitoring of the signals used in developing the final program, by means of the VU-Meters, and CUE control.

This control and monitoring section is divided into four main areas:

- **Control VU meters:** allows you to monitor visually the level of the audio signals from the master output and the CUE bus (or the control monitoring bus, when there are no channels sent to CUE).
- **Programmable keys:** dedicated buttons with special functions defined through the configuration software.
- **Main screen:** it displays the internal menus. This section also incorporates contextual keys and encoders.
- **Studio, Control and Talk-back monitoring:** where you can manage the audio signals sent to the headphones and speakers, for the control room and the studio room, as well as the talk-back functions for the intercom for both areas.

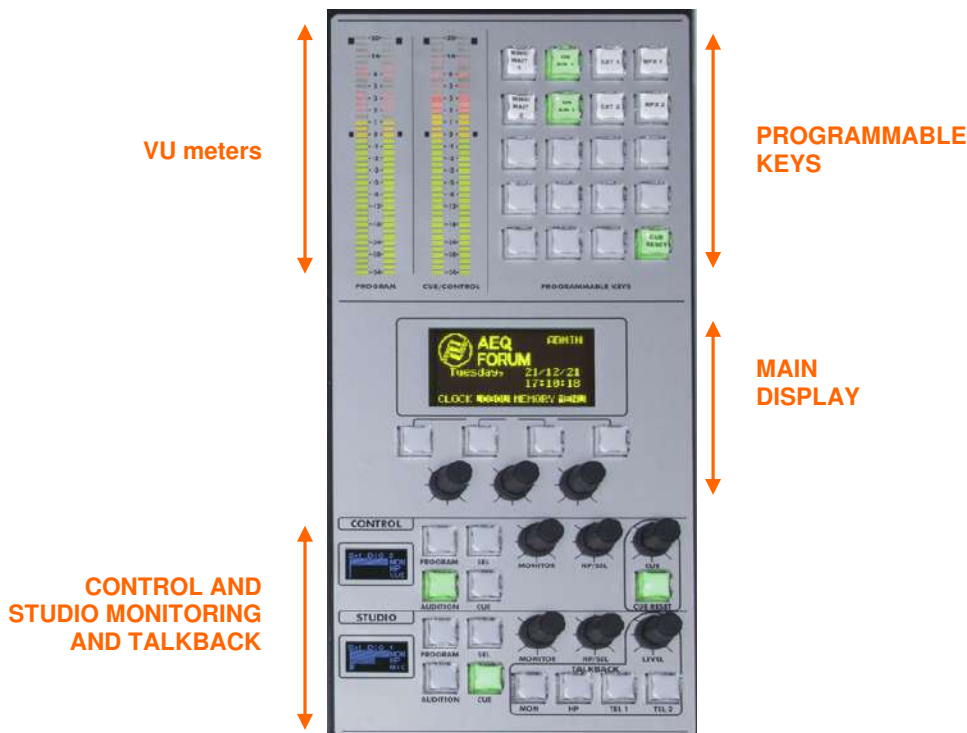

**IMPORTANT NOTE:** In the 2 editions (for **FORUM IP** and **FORUM V2**) of the board that form the control and monitoring section, the control VU meters and the programmable keys are placed in vertical position, while in the edition for **FORUM** they are placed in horizontal position. The operation is not different from the described in the following sections; the only detail to take into account is that in that case the VU meter that shows the Program output is the upper one and the one that shows the CUE bus (or the control monitoring one) is the lower one.

### 2.1.2.1. Control VU meters.

There are two 40 segment LED stereo VU meters. The left one (for **FORUM IP** and **FORUM V2**) shows the **Program** output and the right one (for **FORUM IP** and **FORUM V2**) the **CUE** bus (or the **control monitoring** bus, when there are no channels sent to CUE).

From left to right, the first 25 LEDs are green, followed by an area of 5 yellow LEDs to finish with an area of 10 red LEDs. 0dB point or nominal value corresponds to the yellow LED adjacent to the first red LED.



Both VU meters are set to function as IEC268-10: 5ms/-2dB (vu-meter only) and the peak-meter IEC268-17: 300 ms (vu-meter & Flying PPM) superimposed.

**NOTE:** From the firmware versions of MSC of January 2025, when “Screensaver” mode is active, a “soft” turn off function is added: when the control surface remains unused for an hour, the vumeters are turned off (among other actions aimed at reducing consumption and protect lifetime of displays and keys). For more information, see section 4.2.8 of this manual.

### 2.1.2.2. Programmable keys.

The Control and Monitoring area of the **AEQ FORUM IP** includes 20 programmable keys in 5 rows of 4 columns; 5 rows of 3 columns (15 keys) in the case of **FORUM V2** and 3 rows of 5 columns (15 keys) in the case of **FORUM**.

These programmable keys can be configured through software to perform specific functions such as salvos, GPI, GPO, external codecs control. For more information see section 4.2.1.2 of this manual.



The operation of the programmable keys allows two possibilities:

- **NORMAL:** the pressing of the key triggers the execution of the programmed action. Pressing it again will produce the end of the previously launched action, or in the case of SALVOS, even the opposite action or disconnection of the SALVO.
- **PTT (PUSH-TO-TALK):** the pressing of the key will trigger the execution of the programmed action but only remains active as long as you keep the button pressed.

All keys can be easily labelled, removing the translucent plastic cover and inserting a text label. AEQ supplies with the equipment a template that allows you to create these labels on clear acetate or plain paper.

### 2.1.2.3. Main screen.

The main screen is a two coloured OLED (yellow/black) 128x64 pixel resolution display, that shows the entire internal advanced menu of the console. For more information see section "3. DESCRIPTION OF THE INTERNAL MENU" of this manual.

To simplify operations in the internal menu shown on this screen there are four short-cut keys and three associated rotary encoders. Depending on the information shown on the last line of the menu screen visible on the main display, these short-cut keys will have a function or another.

At most, the last line will have four menu options visible from left to right, and they are directly associated with short-cut keys from left to right.



The three rotary encoders are related to the remaining lines of the menu. Each screen is described in chapter 3 of this manual but the thumb-rule for the association of the rotary encoder to the visible functions is: option visible to the left or in the upper part of the menu is controlled from the encoder located to the left. In many cases the encoders are represented and labelled on the screen for easy operation.

**NOTE:** For firmware version 3.09 of MSC (or 1.56 for previous edition of the board) or higher, after remaining about 5 minutes without being used, the display enters low lighting mode in order to protect its lifetime. Additionally, from the firmware versions of MSC of January 2025, a “soft” turn off function is added that can also be performed manually by keeping pressed for 5 seconds the first contextual key (the leftmost one) of the main screen. For more information, see section 4.2.8 of this manual.

### 2.1.2.4. Control room monitoring section.

Located at the lower part of the AEQ FORUM IP control surface are a two-coloured display, three rotary encoders and four keys.

- In the two-coloured OLED display are shown the output levels for the control monitoring signals and the selected sources in each case, for control headset, control speakers and CUE.



**NOTE:** For firmware version 3.09 of MSC (or 1.56 for previous edition of the board) or higher, when the surface enters low lighting mode (after remaining about 5 minutes without being used), a lateral scroll of that information starts in order to protect the lifetime of the display (that scroll can be deactivated: see section 4.2.8 of this manual). Additionally, from the firmware versions of MSC of January 2025, a “soft” turn off function is added (for more information, see section 4.2.8 of this manual).

- The three rotary encoders, from left to right, are:
  - **"MONITOR"**: it controls the audio level for the physical output for the control room monitors. To decrease the level, turn the encoder to the left. To increase the level, turn the encoder to the right.
  - **"HP/SEL"**: it controls the audio level for the physical output for the control headphones. To decrease the level, turn the encoder to the left. To increase the level, turn the encoder to the right. This encoder can also be used to select the signal to monitor associated with the key "SEL": press to access a list of signals, and turn the encoder to move up or down in the list of signals; pushing the encoder a second time confirms the selection of the highlighted signal.



- **"CUE"**: it controls the audio level of the CUE speaker of the AEQ FORUM. To decrease the level, turn the encoder to the left. To increase the level, turn the encoder to the right.
- The four keys at the right of the display, from top to bottom and left to right, allows to select the signal to monitor on control speakers and headset, from left to right:
  - **"PROG"**: allows you to monitor the audio signal **Program**.
  - **"AUD"**: allows you to monitor the audio signal **Audition**.
  - **"SEL"**: allows you to monitor any signal of the console previously selected by means of "HP/SEL" encoder.
  - **"CUE"**: allows you to monitor the audio signal present on the CUE bus.

These four keys can have two working modes that are selected from the Configuration Software (see section 4.2.4 of this manual):

- **"Mixer"**: each key pressed adds the signal to be monitored to the summing bus.
- **"Exclusive"**: each key pressed connects the signal to the summing bus and disconnects any signal previously selected.

In case there are no channels sent to CUE, the signal or signals selected in this section will be shown in the lower control VU meter (see section 2.1.2.1 of this manual).

There are two types of programmable key ("**Auto Cue**" and "**Split CUE**") that allow you to modify the working mode of this section (see sections 4.3.2.10 and 4.3.2.13 of this manual).

- The **"CUE RESET"** key (only in the case of **FORUM IP**) allows to disconnect all active signals sent to the CUE bus and turn off the "CUE" buttons activated on the corresponding channels. There is also the option of setting one of the programmable keys as "CUE RESET" key (see section 4.3.2.6 of this manual).

**NOTE:** There is a type of programmable key ("**Remote Production**") that allows you to modify the working mode of this section (see section 4.3.2.14 of this manual).

### 2.1.2.5. Studio room monitoring section.

Located at the lower part of the AEQ FORUM IP control surface are a two-coloured display, two rotary encoders and four keys.

- In the two-coloured OLED display are shown the output levels for the studio monitoring signals and the selected sources in each case, for studio headset, studio speakers and CUE.

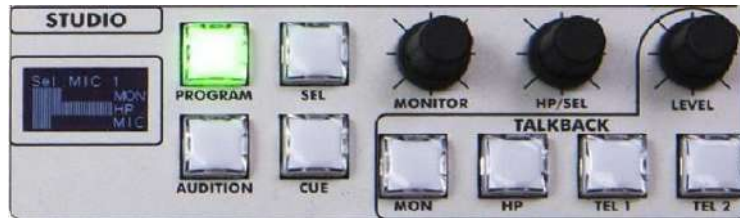

**NOTE:** For firmware version 3.09 of MSC (or 1.56 for previous edition of the board) or higher, when the surface enters low lighting mode (after remaining about 5 minutes without being used), a lateral scroll of that information starts in order to protect the lifetime of the display (that scroll can be deactivated: see section 4.2.8 of this manual). Additionally, from the firmware versions of MSC of January 2025, a “soft” turn off function is added (for more information, see section 4.2.8 of this manual).

- The two rotary encoders, from left to right, are:
  - **"MONITOR"**: it controls the audio level for the physical output for the studio room monitors. To decrease the level, turn the encoder to the left. To increase the level, turn the encoder to the right.
  - **"HP/SEL"**: it controls the audio level for the physical output for the studio headphones. To decrease the level, turn the encoder to the left. To increase the level, turn the encoder to the right. This encoder can also be used to select the signal to monitor associated with the key "SEL": press to access a list of signals, and turn the encoder to move up or down in the list of signals; pushing the encoder a second time confirms the selection of the highlighted signal.



- The four keys at the right of the display, from top to bottom and left to right, allows to select the signal to monitor on studio speakers and headset, from left to right:
  - **"PROG"**: allows you to monitor the audio signal **Program**.
  - **"AUD"**: allows you to monitor the audio signal **Audition**.
  - **"SEL"**: allows you to monitor any signal of the console previously selected by means of "HP/SEL" encoder.
  - **"CUE"**: allows you to monitor the audio signal present on the CUE bus.

These four keys can have two working modes that are selected from the Configuration Software (see section 4.2.4 of this manual):

- **"Mixer"**: each key pressed adds the signal to be monitored to the summing bus.
- **"Exclusive"**: each key pressed connects the signal to the summing bus and disconnects any signal previously selected.

**NOTE:** There is a type of programmable key (**"Remote Production"**) that allows you to modify the working mode of this section (see section 4.3.2.14 of this manual).

### 2.1.2.6. Talkback.

Talk-back section allows the console operator to communicate directly with the studio and remote guests (lines).

The default intercom channels for the AEQ FORUM are between the control room and the studio, independent between monitors and headphones. You can set additional channels of intercom to facilitate communications. For example, talk-back can be established between studio or control to the different audio returns to hybrids or audiocoders. The talk-back microphone can also be used as an auto-control microphone if so defined.

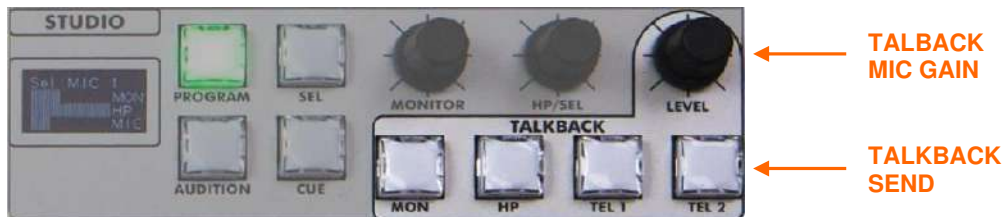

The talk-back section of the control surface consists of 1 rotary encoder and 4 key buttons at the lower part of the Control and Monitoring section.

The encoder "**LEVEL**" (Talkback Level) controls the gain of the TALKBACK microphone. To decrease the level, turn the encoder to the left. To increase the level, turn the encoder to the right.

Regarding the keys, from left to right are:

- "**MON**": talk-back to studio monitors.
- "**HP**": talk-back to studio headphones. The default configuration of the AEQ FORUM does not differentiate between primary and secondary headphones. It is possible to establish a secondary group of headphones creating a salvo to be triggered from the programmable keys.
- "**TEL 1**": talk-back to the telephone hybrid line 1 (AEQ FORUM allows a maximum of 2 single line digital telephone hybrid modules **FR33**, but has up to 10 MPX internal buses hidden that can be used with dedicated lines, external audiocoders or telephone hybrids. The talk-back to dedicated lines, external audiocoders or telephone hybrids can be established through the use of the programmable keys).
- "**TEL 2**": talk-back to the telephone hybrid line 2.

**NOTE:** There is a type of programmable key ("**Remote Production**") that allows you to dynamically configure the signal to be used as orders/autocontrol microphone (see section 4.3.2.14 of this manual).

### 2.1.3. Ventilation grille.

The base of the equipment and the top of the control surface have micro-perforations to allow the passing of a stream of air naturally created by convection due to the heat dissipated by the equipment electronics. The distance from the equipment base to the table top has to be respected by at least the height of the equipment rubber feet and it is paramount not to obstruct the ventilation grille on the top of the control surface.

The AEQ FORUM design does not include a fan or mechanical heat sink thus ensuring silent operation, perfect for self-control facilities or applications that require absolute silence.

The right side of the vent area integrates the CUE speaker (except in the case of AEQ FORUM IP SPLIT).

#### **2.1.4. Wrist-rest and side trims.**

The AEQ FORUM has a frame around the sides and bottom of the control surface, forming part of the chassis that houses all the electronics. This framework is transformed into a wrist-rest at the bottom.

The standard AEQ FORUM is delivered with wooden side trims and a wrist-rest for desktop installation of the mixer. As an option, the AEQ FORUM can be provided without the side trims and with L-shaped metal profiles to allow the countersunk installation of the mixing console.

## 2.2. Description of the rear panel and connections.

The ease of installation and set-up has been a priority in the design of AEQ FORUM. The equipment is self-contained (except in the case of AEQ FORUM IP SPLIT) and can be installed either desktop or countersunk.

To connect cough cut, remote control of external devices, ON AIR lights, etc... AEQ FORUM has 8 general purpose inputs (GPI), 8 general purpose outputs (GPO) and another 4 relay outputs. The AEQ FORUM has a set of predefined control and studio monitors and headphones including auto-control and orders microphone. Remote configuration and control are via two Ethernet connections.

AEQ FORUM also features 246 **virtual** GPIs and 242 **virtual** GPOs; these virtual GPIs and GPOs are general purpose inputs and outputs that are respectively related to virtual GPOs and GPIs of other units through an IP network, so the control is carried through the IP network between different units.

AEQ FORUM has an optional bi-directional MADi interface (available by means of user license) that can carry up to 64 digital inputs and outputs as well as 14 slots for analogue or digital I/O and digital telephone hybrid modules.

For ease of wiring and avoid errors in the installation process, audio and data cables and DB connectors required to connect the console can be optionally supplied. In any event, it is necessary to use shielded and balanced audio cables and that the connection to the DB connectors is made by technically qualified personnel and properly verified before connecting the equipment. Further, optional power supplies and wiring for control and studio signalling and GPIO can be supplied.



The AEQ FORUM's 14 available slots for inputs/outputs modules are labelled from 1 to 14 starting from the right of the console, rear view, reserving the number 15 for the system common I/O module (except in the case of AEQ FORUM IP SPLIT, where this area is located in the upper part of the "core"), and the name AES10 MADi for the MADi interface option (available by means of user license). These references are the same as those used in the configuration software. For more information see chapter "3. DESCRIPTION OF THE INTERNAL MENU" of this manual.



### 2.2.1. Power supply. A

On the left side of rear FORUM is placed the power supply module which incorporates the DC/DC converters that provides the internal circuitry power of the console. Externally you can see the 48V DC Speak-On connector to which the external 48V DC power supply is connected. The power supply provided is switching and supports between 100 and 240VAC, delivering 160W-3, 34A @ 48 V DC.



AEQ FORUM external power supply

On request, a redundant 2RU rack-mounted power supply can be delivered. In the case of installing this redundant power supply, it has to be adequately located so as to avoid the hum of the fans installed in the power supply being picked up by any microphone.



Redundant power supply for AEQ FORUM

In the case of **AEQ FORUM IP SPLIT**, the power supply module is located at the left of the "core" back panel. It supplies the internal voltages to "core" and control surface. It consists on a universal auto-range switching power supply that can operate with worldwide mains: 90 - 132 V AC & 187 – 264 V AC, 47/63Hz. Optionally, a second (backup) internal power supply can be installed in order to have redundancy. If two power supplies are used, it is recommended that one of them is connected to a UPS while the other can be connected to regular mains.



The data and power supply output from console to control surface is located at the right of the power supply input. It is designed for use with straight Ethernet cabling, but also carries proprietary **power supply lines**. Please use the cable provided with the unit only. If necessary, this connection could be made by means of a cable of up to 250 meters, using a continuous **CAT5E shielded** (FTP) cable (or better) and checking that the **shield** is connected to the connectors case.

**IMPORTANT NOTE: Do not connect this output to any device but the control and monitoring module** (there is a severe risk of damage to other equipment or even the "core" itself). In order to avoid any damage to the unit is **VERY IMPORTANT** to turn off the unit before connecting or disconnecting this cable.



## 2.2.2. System common I/O's. B

This section of the AEQ FORUM rear panel includes inputs and outputs required to integrate the equipment in a broadcast facility such as audio outputs to several external speakers and headphones, general purpose inputs and outputs allowing remote options or talk-back microphone.



In the case of **AEQ FORUM IP SPLIT**, this area is located in the upper part of the "core"



AEQ FORUM IP SPLIT also includes in this area a stereo line output for **CUE** or prelisten speakers on TRS 3,5 mm 1/8" jack, unbalanced connection. This connector (typical of self amplified PC speakers) has been chosen to simplify the selection of this component among a wide range of cost-effective solutions. **IMPORTANT:** This is not a power output, so you cannot connect speakers that are not self amplified.



### 2.2.2.1. GPIO.

AEQ FORUM incorporates several electronic general purpose interfaces (GPIO), either of the opto-coupled or physical contact type and always available on the rear panel of the unit. AEQ FORUM also features virtual GPIOs over IP network.

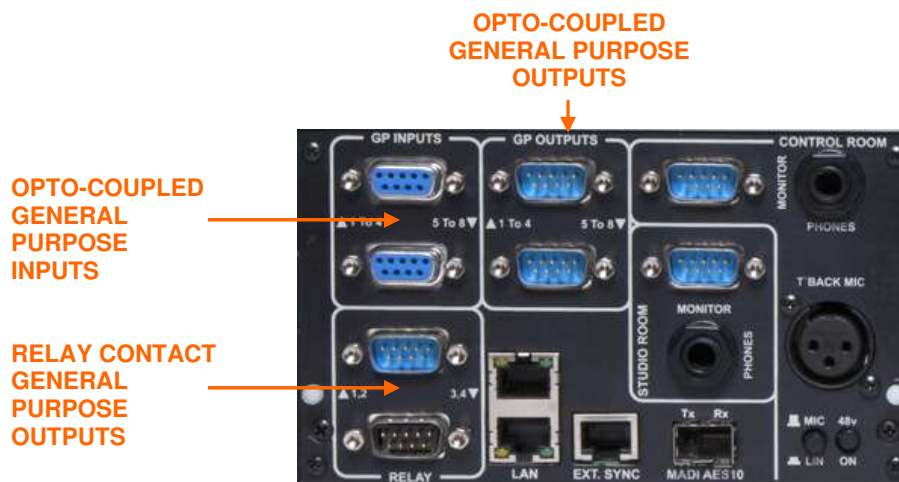

### 2.2.2.1.1. Opto-coupled GPI.

The AEQ FORUM includes 8 electronic interfaces of opto-coupled type GPIs through the two female DB9 connectors in the "**GP INPUTS**" section. One of them houses the GPIs numbered from 1 to 4 and the other one from 5 to 8.

Specifications:

- Opto-coupler protected inputs (TLP127).
- Maximum Input Current: 50mA.
- Applicable voltage: from 5V to 24V.

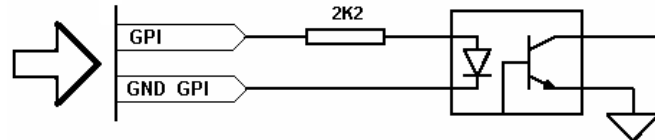

Electronic associated with opto-coupled GPI

In order to simplify the installation, AEQ offers a prefabricated wiring kit specifically for GPI inputs: FR-CAB-GPI, male DB9 connector soldered to 4 meters of cable open-end termination for GPI. More information in section 2.2.4 of this manual.

GPI inputs (2 x SUB-D female 9 pin):

Pin	GP INPUTS 1 To 4 connector	GP INPUTS 5 To 8 connector
1	GPIN1	GPIN5
2	GPIN2	GPIN6
3	GPIN3	GPIN7
4	GPIN4	GPIN8
5	Not connected	Not connected
6	GND GPIN1	GND GPIN5
7	GND GPIN2	GND GPIN6
8	GND GPIN3	GND GPIN7
9	GND GPIN4	GND GPIN8

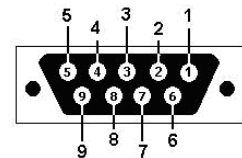

On request, this wiring kit can be supplied with connectors explicitly specified by the customer. For more information, please refer to AEQ sales department or authorised distributors.

### 2.2.2.1.2. Opto-coupled GPO.

The AEQ FORUM includes 8 electronic interfaces of opto-coupled type GPOs through the two male DB9 connectors in the "**GP OUTPUTS**" section. One of them houses the GPOs numbered from 1 to 4 and the other one from 5 to 8.

Specifications:

- Opto-coupler protected outputs (TLP127).
- Maximum current: 80mA.
- Recommended Maximum voltage: 200V.
- Maximum power: 100mW at 40 ° C.
- Requires external power.

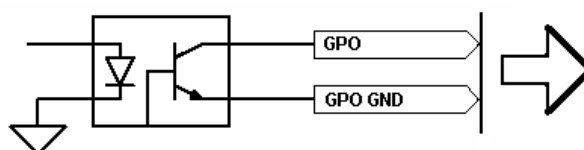

Electronic associated with opto-coupled GPO

In order to simplify the installation phase, AEQ offers a prefabricated wiring kit specifically for GPO outputs: FR-CAB-GPO, female DB9 connector soldered to 4 meters of cable open-end termination for GPO. More information in section 2.2.4 of this manual.

GPO outputs (2 x SUB-D male 9 pin):

Pin	GP OUTPUTS 1 To 4 connector	GP OUTPUTS 5 To 8 connector
1	GPOUT1	GPOUT5
2	GPOUT2	GPOUT6
3	GPOUT3	GPOUT7
4	GPOUT4	GPOUT8
5	Not connected	Not connected
6	GND_GPOUT1	GND_GPOUT5
7	GND_GPOUT2	GND_GPOUT6
8	GND_GPOUT3	GND_GPOUT7
9	GND_GPOUT4	GND_GPOUT8

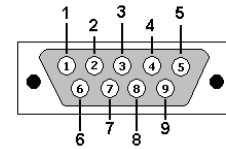

On request, this wiring kit can be supplied with connectors explicitly specified by the customer. For more information, please refer to AEQ sales department or authorised distributors.

### 2.2.2.1.3. Physical contact GPO.

The AEQ FORUM includes 4 physical contact type GPOs through the two male DB9 connectors in the "RELAY" section. One of them houses the GPOs numbered from 1 to 2 and the other one from 3 to 4.

Specifications:

- Contact closure relay.
- Maximum current: 1 A @ 30 v. DC, 0.3 A @ 125 V AC.
- Maximum voltage: 60 V DC or 125 v. AC.
- Maximum power: 30 VA.

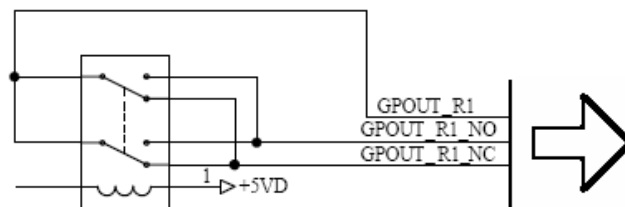

Electronic associated with physical contact GPO

In order to simplify the installation phase, AEQ offers a prefabricated wiring kit specifically for GPO outputs: FR-CAB-RELE, female DB9 connector soldered to 4 meters of cable open-end termination for GPO. More information in section 2.2.4 of this manual.

GPO Relay outputs (2 x SUB-D male 9 pin):

Pin	RELAY 1,2 connector	RELAY 3,4 connector
1	GPOUT_RL1_COM	GPOUT_RL3_COM
2	GPOUT_RL1_NO	GPOUT_RL3_NO
3	Not connected	Not connected
4	Not connected	Not connected
5	GPOUT_RL2_NC	GPOUT_RL4_NC
6	Not connected	Not connected
7	GPOUT_RL1_NC	GPOUT_RL3_NC
8	GPOUT_RL2_COM	GPOUT_RL4_COM
9	GPOUT_RL2_NO	GPOUT_RL4_NO

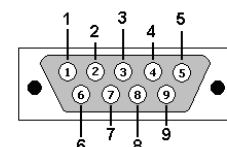

COM: common  
NO: normally open  
NC: normally close

On request, this wiring kit can be supplied with connectors explicitly specified by the customer. For more information, please refer to AEQ sales department or authorised distributors.

### 2.2.2.2. Ethernet ports.

In the area of common inputs and outputs of the AEQ FORUM are two 10/100 Base T RJ45 Ethernet connectors to interconnect the mixing console with external devices using IP communication protocols.



LAN (lower) and ETHERNET (top) connectors

Any of the two connectors can be used to interconnect the AEQ FORUM with an external computer that is running the configuration software. By default, the IP address associated with "LAN" port is 172.31.34.1 and the one associated with "ETHERNET" port is 172.26.34.1: both addresses can be modified if you have the right user level (see section 3.4). For further information see chapter "4. CONFIGURATION SOFTWARE" of this manual.

**IMPORTANT NOTE 1: The IP addresses of both Ethernet ports must not be configured into the same network.** For instance, if "LAN" port is configured with 172.31.34.1 IP address and 255.255.0.0 mask, the IP address of the "ETHERNET" port should be different from 172.31.x.x (where x is any number between 0 and 255).

**IMPORTANT NOTE 2: The "ETHERNET" port is the one that must be necessarily used for connecting to "FORUM SCREEN" or for using the "Visual Radio" functionality (as all the vumeters are only sent by this interface) and also if you want to use virtual GPIs or GPOs.**

The RJ45 pin-out is as follows:

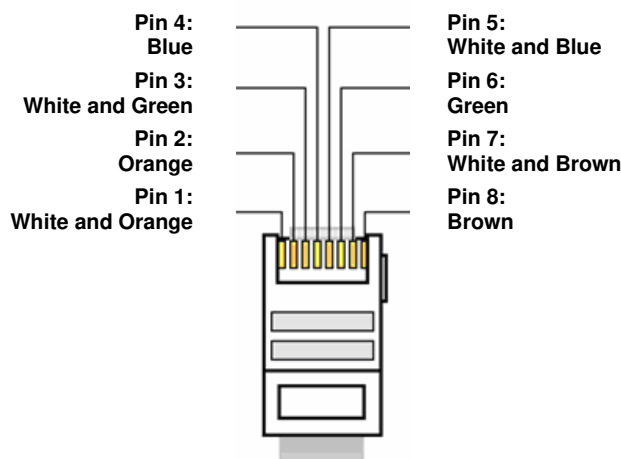

### 2.2.2.3. Synchronism.

AEQ FORUM has an external sync input for AES 11 and TTL formats. The input connector is an RJ45 on the rear panel of the unit identified as "**EXT. SYNC**".

Pin	EXT.SYNC connector
1	TTL SYNC IN
2	TTL SYNC IN GND
3	TTL SYNC OUT
4	GND
5	AES SYNC OUT+
6	AES SYNC OUT-
7	AES SYNC IN+
8	AES SYNC IN-
Case	Earth

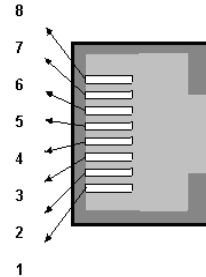

### 2.2.2.4. Control and studio monitors.

AEQ FORUM includes monitor outputs for Studio and Control monitors. These outputs are provided on a male DB9 connector.

The speaker output for the control is called "**MONITOR**" and within the "**CONTROL ROOM**" section on the rear panel of the equipment.

The speaker output for the studio is called "**MONITOR**" and within the "**STUDIO ROOM**" section on rear panel of the equipment.

In order to simplify the installation phase, AEQ offers a prefabricated wiring kit specifically for monitoring outputs: FR-CAB-MON, female DB9 connector soldered to 4 metres of cable open-end termination for two monitor outputs. More information in section 2.2.4 of this manual.

Control / Studio Monitoring outputs (SUB-D male 9 pin):

Pin	MONITOR STUDIO connector	MONITOR CONTROL connector
1	GND	GND
2	OUT L-	OUT L-
3	Not connected	Not connected
4	GND	GND
5	OUT R-	OUT R-
6	OUT L+	OUT L+
7	Not connected	Not connected
8	Not connected	Not connected
9	OUT R+	OUT R+

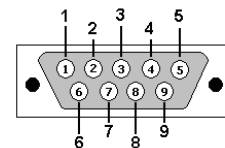

On request, this wiring kit can be supplied with connectors explicitly specified by the customer. For more information, please refer to AEQ sales department or authorised distributors.

**IMPORTANT NOTE:** If you want to connect any of the outputs to an unbalanced input, you must unbalance the output, using the corresponding positive and GND pins and leaving the negative pin unconnected. Also keep in mind that unbalancing the output will reduce its level by 6dB.

### 2.2.2.5. Control and studio headphones.

AEQ FORUM includes studio and control headphones outputs on asymmetric connection 1/4" (6,3 mm) Phone Jack Connectors.

The control headphones output is identified as "**PHONES**" in the "**CONTROL ROOM**" section on the rear panel of the equipment.

The studio headphones output is identified as "**PHONES**" in the "**STUDIO ROOM**" section on the rear panel of the equipment.

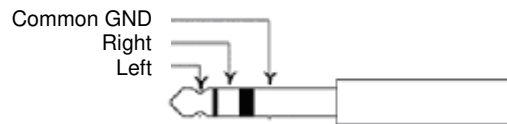

### 2.2.2.6. Orders microphone.

Talk-back or orders microphone input is identified as "**T'BACK MIC**" in the "**CONTROL ROOM**" section on the rear panel of the AEQ FORUM. The input includes MIC/LINE and Phantom ON/OFF selectors. XLR - Female 3p. Balanced connection.

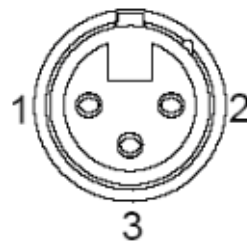

Pin 1 → GND  
Pin 2 → Input +  
Pin 3 → Input -

**IMPORTANT NOTE 1:** Regarding the wiring, the chassis of microphones must be connected to the chassis of the console frame in order to protect the microphone inputs against uncontrolled static shocks. Pin 1 (Ground) must be connected to the metal case of XLR connector in the available terminal for this purpose, so any static shock will be downloaded to ground through the frame chassis. This rule must be followed in every connector throughout the cable in case of connections by means of aerial connectors. In the same way, for AES3 or USB digital signals, the chassis of PCs or other digital audio devices must be also connected to the chassis of the console frame.

**IMPORTANT NOTE 2:** In the case of **AEQ FORUM IP SPLIT**, there is an edition of the common I/O's module that doesn't include MIC/LINE and Phantom ON/OFF selectors as that configuration is accomplished from configuration software (see section 4.3.5.1 of this manual) or from the "CFG" menu in the main display of the Control and Monitoring section in the control surface (see section 3.4.3.1.3.1 of this manual).



### 2.2.2.7. Optional MADI communications module.

On the rear panel of AEQ FORUM you can find the physical connector for the AES10 - MADI interface built into the console. The connector is an SFP chassis (Small Form-Factor Pluggable - SFP) where you allocate the optional fiber-optic transceiver.

MADI protocol, which stands for multichannel audio digital interface is a professional standard of data transmission for digital audio signals over 56 channels on a single cable. MADI protocol is documented in the standard AES10-1991 and ANSI s4.43-1991.

AES10 MADI multichannel interface is an extension of AES3 protocol for interconnection of multi-channel. MADI protocol, as defined in the AES10 standard allows connection of up to 64 audio channels (linearly quantified data) with a resolution of 24 bits per sample and a sampling rate frequency of 48 kHz/s. Transmission is accomplished in a serial mode and if transmission is done on a single 75 ohm coaxial cable with BNC connectors the distance reached is greater than 50 m. If transmission is accomplished on a multi-mode fiber-optic interface the distance is up to 2 km.



The audio samples may have a maximum of 32 bit quantization. Additionally, by using this protocol, the bits of validity user status and parity of AES3 are maintained. The MADI protocol allows you to connect 64 audio channels with a single pair of wires. The data bit rate is 100 Mbits/s corresponds to a synchronous connection.

MADI Interface Specifications:

- Optical fiber connector, FDDI PMD type.
- Nominal range: 2.000 meters
- Fiber Type: 62.5 / 125  $\mu$ m MULTIMODE MULTIMODO
- Transmission: LED, 1300 nm

**NOTE 1:** In order to activate this function, you must purchase a user license.

**NOTE 2:** **MADI** functionality is not compatible with **AoIP** (audio over IP) functionality, both options can't be active at the same time.

### 2.2.3. Audio inputs/outputs modules. C

FORUM AEQ includes enough space in its rear panel to accommodate a maximum of 14 independent modules of audio inputs and/or outputs in various formats. Depending on the type of audio processed, each of these modules receives a specific identifier within the family of products AEQ FORUM. AEQ is continuously developing new features for AEQ FORUM in order to meet the market demands for different solutions.

Below is the list of modules currently available:

- **FR02:** 4 inputs and 4 outputs, digital stereo AES/EBU or SPDIF module.
- **FR03 / FR03S:** 2 mic/line (selectable) inputs module.
- **FR04:** 8 analogue mono line level inputs module.
- **FR05:** 8 analogue mono line level outputs module.
- **FR14:** 32 mono input channels and 32 mono output channels for audio over IP (AoIP).
- **FR22:** 4 inputs and 4 outputs, digital stereo USB module.
- **FR33:** digital telephone hybrid module.

Using the modules described above, in the numbers and available free position of the 14 available slots on the rear panel of AEQ FORUM, each customer can customize their AEQ FORUM mixing console to exactly fit its specific requirements and applications.

In order to simplify the installation phase, AEQ offers a prefabricated wiring kits for the different audio inputs and outputs modules available. More information in section 2.2.4 of this manual.

**IMPORTANT NOTE:** Regarding the wiring, the chassis of microphones must be connected to the chassis of the console frame in order to protect the microphone inputs against uncontrolled static shocks. Pin 1 (Ground) must be connected to the metal case of XLR connector in the available terminal for this purpose, so any static shock will be downloaded to ground through the frame chassis. This rule must be followed in every connector throughout the cable in case of connections by means of aerial connectors. In the same way, for AES3 or USB digital signals, the chassis of PCs or other digital audio devices must be also connected to the chassis of the console frame.

### 2.2.3.1. FR02 Digital inputs/outputs module.

The AEQ FORUM FR02 module includes 4 AES/EBU or SPDIF stereo digital inputs and 4 AES/EBU or SPDIF stereo digital outputs on two DB15 connectors.



The 4 digital inputs on the FR02 are available through a female DB15 connector identified as "AES/EBU 4 STEREO INPUTS". The 4 digital outputs on the FR02 are available through a male DB15 connector identified as "AES/EBU 4 STEREO OUTPUTS".

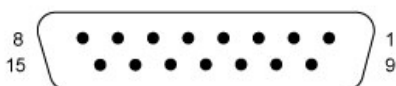

DB15 female connector pin-out detail

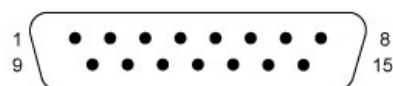

DB15 male connector pin-out detail

Pin	AES/EBU 4 STEREO INPUTS connector
1	IN1+
2	GND
3	IN2+
4	GND
5	IN3+
6	GND
7	IN4+
8	GND
9	IN1-
10	GND
11	IN2-
12	GND
13	IN3-
14	GND
15	IN4-

Pin	AES/EBU 4 STEREO OUTPUTS connector
1	OUT1+
2	GND
3	OUT2+
4	GND
5	OUT3+
6	GND
7	OUT4+
8	GND
9	OUT1-
10	GND
11	OUT2-
12	GND
13	OUT3-
14	GND
15	OUT4-

The module FR02 includes SRC (Sample-Rate-Converters) for all inputs. The digital audio format for each input is irrelevant in the process of installation and configuration since it is being managed automatically and transparently to the user.

By changing some jumpers on the FR02 module you can work with digital signals in SPDIF format. In the module you can see, for each one of the 4 inputs and 4 outputs, the jumpers position in order to configure them as AES3 or SPDIF:

<b>Jumpers</b>		<b>Jumpers</b>	
<b>Digital input 1</b>	J1, J2, J3, J5 and J7	<b>Digital output 1</b>	J4, J6, J8 and J9
<b>Digital input 2</b>	J10, J11, J12, J14 and J16	<b>Digital output 2</b>	J13, J15, J17 and J18
<b>Digital input 3</b>	J20, J21, J22, J26 and J28	<b>Digital output 3</b>	J25, J27, J29 and J30
<b>Digital input 4</b>	J31, J32, J34, J36 and J38	<b>Digital output 4</b>	J35, J37, J39 and J42

**Position 1-2: AES3**  
**Position 2-3: SPDIF**

**IMPORTANT NOTE:** Regarding the wiring, the chassis of microphones must be connected to the chassis of the console frame in order to protect the microphone inputs against uncontrolled static shocks. Pin 1 (Ground) must be connected to the metal case of XLR connector in the available terminal for this purpose, so any static shock will be downloaded to ground through the frame chassis. This rule must be followed in every connector throughout the cable in case of connections by means of aerial connectors. In the same way, for AES3 or USB digital signals, the chassis of PCs or other digital audio devices must be also connected to the chassis of the console frame.

### 2.2.3.2. FR03 / FR03S Mic/Line inputs module.

The AEQ FORUM FR03 / FR03S module includes 2 switchable monophonic microphone/line level on two female XLR connectors.



Each of the two Mic/Line inputs available on the FR03 module includes separate controls on dedicated hardware button to select your operation as microphone or line input, as well as the activation or deactivation of the +48V **Phantom** power available.

The modification or activation of any of these options can be monitored from the internal menu available in the main screen of the Control and Monitoring section and monitors in the control surface FORUM AEQ. For more information see section "3.4.3.1.3. Expanded information menu" in this manual.

XLR - Female 3p. Balanced connection.

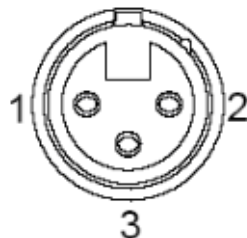

- Pin 1 → GND
- Pin 2 → Input +
- Pin 3 → Input -

**NOTE 1:** The physical location of the FR03 / FR03S modules present in a normal configuration of AEQ FORUM is limited to the first 4 of the 14 available slots on the rear panel of console. Therefore, the maximum number of microphones present in any AEQ FORUM console is 9, 8 through the FR03 modules connected and one more microphone connected to "T'BACK MIC" input.

**NOTE 2:** Only when the FR03 module edition is previous to edition 4 and the firmware version of the CPU module of BASE PBA is previous to 1.44, in case you use a microphone that needs **Phantom** power it's important that you activate that option only when the microphone is already connected to the corresponding input, in order to avoid unconfigure the gain of the rest of the microphones (anyway it's possible to recover those gains configuration just by refreshing the gain of at least one microphone per module).

**IMPORTANT NOTE 1:** Regarding the wiring, the chassis of microphones must be connected to the chassis of the console frame in order to protect the microphone inputs against uncontrolled static shocks. Pin 1 (Ground) must be connected to the metal case of XLR connector in the available terminal for this purpose, so any static shock will be downloaded to ground through the frame chassis. This rule must be followed in every connector throughout the cable in case of connections by means of aerial connectors. In the same way, for AES3 or USB digital signals, the chassis of PCs or other digital audio devices must be also connected to the chassis of the console frame.

**IMPORTANT NOTE 2:** There is an edition of the Mic/Line inputs module that doesn't include MIC/LINE and Phantom ON/OFF selectors as that configuration is accomplished from configuration software (see section 4.3.5.1 of this manual) or from the "CFG" menu in the main display of the Control and Monitoring section in the control surface (see section 3.4.3.1.3.1 of this manual). The serigraph of that edition identifies the module as **FR03S**.



### 2.2.3.3. FR04 Analogue line inputs module.

The AEQ FORUM FR04 module incorporates 8 electronically balanced monophonic line level inputs and are available physically through two DB15 female connectors identified as "ANALOG INPUTS 1 To 4" (upper) and "ANALOG INPUTS 5 To 8" (lower).

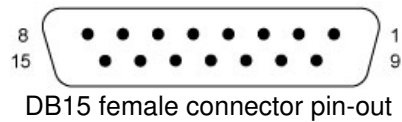
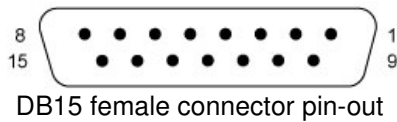

Pin	ANALOG INPUTS 1 To 4 connector
1	IN1+
2	GND
3	IN2+
4	GND
5	IN3+
6	GND
7	IN4+
8	GND
9	IN1-
10	GND
11	IN2-
12	GND
13	IN3-
14	GND
15	IN4-

Pin	ANALOG INPUTS 5 To 8 connector
1	IN5+
2	GND
3	IN6+
4	GND
5	IN7+
6	GND
7	IN8+
8	GND
9	IN5-
10	GND
11	IN6-
12	GND
13	IN7-
14	GND
15	IN8-

Depending on the specific application or installation required, the 8 monophonic inputs can be configured as 4 stereo inputs using the configuration software. For more information see section "4.2.3. I/O Configuration submenu" of this manual.

#### 2.2.3.4. FR05 Analogue line outputs module.

The AEQ FORUM FR05 module incorporates 8 electronically balanced monophonic line level outputs and are available physically through two DB15 male connectors identified as "ANALOG OUTPUTS 1 To 4" (upper), and "ANALOG OUTPUTS 5 To 8" (lower).

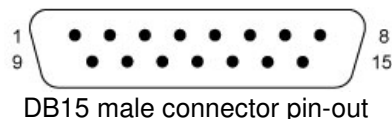
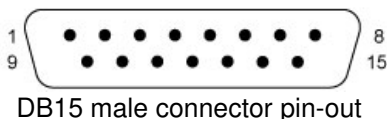

Pin	ANALOG OUTPUTS 1 To 4 connector
1	OUT1+
2	GND
3	OUT2+
4	GND
5	OUT3+
6	GND
7	OUT4+
8	GND
9	OUT1-
10	GND
11	OUT2-
12	GND
13	OUT3-
14	GND
15	OUT4-

Pin	ANALOG OUTPUTS 5 To 8 connector
1	OUT5+
2	GND
3	OUT6+
4	GND
5	OUT7+
6	GND
7	OUT8+
8	GND
9	OUT5-
10	GND
11	OUT6-
12	GND
13	OUT7-
14	GND
15	OUT8-

Depending on the specific application or installation, the 8 mono outputs can be configured as 4 stereo outputs from the configuration software. For more information see section "4.2.3. I/O Configuration submenu" of this manual.

**IMPORTANT NOTE:** If you want to connect any of the outputs to an unbalanced input, you must unbalance the output, using the corresponding positive and GND pins and leaving the negative pin unconnected. Also keep in mind that unbalancing the output will reduce its level by 6dB.

#### 2.2.3.5. FR14 AoIP module.

The AEQ FORUM FR14 AoIP module is installed as any other input/output module on the rear panel of the console and gives you up to 32 input audio channels and up to 32 output audio channels.

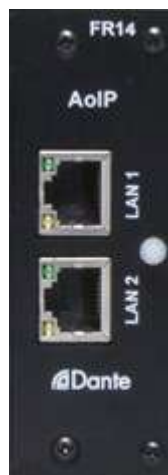

The module has 2 Ethernet connectors identified as "LAN 1" (main interface) and "LAN 2" (secondary interface), both with its corresponding signalling LEDs. Those LEDs indicate the status of audio local network connection:

- Off: no local network connection.
- Blinking green: link established at data level.
- Fixed yellow: link established at physical level.

**IMPORTANT NOTE:** The maximum number of FR14 modules present in any AEQ FORUM console is 2, and these will always be installed in **slots 13 and 14** of the 14 available slots on the rear panel. When there is only one FR14 module installed, it will be placed in **slot 14**.

**AoIP** (audio over IP) functionality is not compatible with **MADI** functionality, both options can't be active at the same time.

#### 2.2.3.6. FR22 USB inputs/outputs module.

The AEQ FORUM FR22 module includes 4 USB stereo digital inputs and 4 USB stereo digital outputs on four female USB B type connectors.

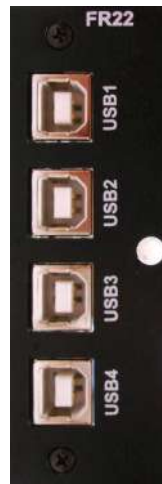

One stereo digital input and one stereo digital output are available through each one of the four USB connectors.

When you connect a USB module to a PC through any of the USB ports, the PC will automatically recognize it as a new audio device (it will be shown as "USB Audio CODEC"). To this device you can send audio from any audio playback application in the same way as if it was an external professional audio board. It is also possible to record any audio from the mixing console in the computer by using any recording application.

These boards are "plug&play" on Microsoft Windows™ and Apple Computer Mac OS™ operative systems, no specific driver is needed. When you connect several USB ports from one or several USB modules to the same PC, the operative system will show a new audio device for each one, that will be identified as "USB Audio CODEC", "USB Audio CODEC (2)"...

Supported input sampling frequencies are 32 KHz, 44.1 KHz and 48 KHz, with sampling rate converters (SRC) to 48 KHz that corresponds to the internal sampling rate of the system.

**IMPORTANT NOTE 1:** It's necessary to use shielded cable in order to establish connection between USB module and PC.

**IMPORTANT NOTE 2:** Regarding the wiring, the chassis of microphones must be connected to the chassis of the console frame in order to protect the microphone inputs against uncontrolled static shocks. Pin 1 (Ground) must be connected to the metal case of XLR connector in the available terminal for this purpose, so any static shock will be downloaded to ground through the frame chassis. This rule must be followed in every connector throughout the cable in case of connections by means of aerial connectors. In the same way, for AES3 or USB digital signals, the chassis of PCs or other digital audio devices must be also connected to the chassis of the console frame.

### 2.2.3.7. FR33 Telephone hybrid module.

The AEQ FORUM can incorporate up to two modules FR33 as internal digital telephone hybrids, each of which have the capacity to manage a single telephone line.



Each FR33 module includes two RJ11 connectors, one is labelled "**LINE**" and to which the telephone line connection is accomplished. The other is labelled as "**SET**" and used to connect an external telephone terminal from where you can dial the required number or answering a call prior to placing the call ON-AIR.

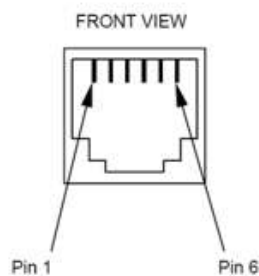

RJ11 connector

The configuration of the signals present in the FR33 module and associated controls is accomplished from the configuration software. For more information, please refer to section "4.2. Hardware Configuration menu" of this manual.

Depending on the version of firmware installed the configuration options related to the FR33 Digital Telephone Hybrid module may not be available. It may be necessary to use external communication devices and for which the programmable keys of the AEQ FORUM can be used. For more information, please refer to section "4.3.2.4. Configuration of Codec programmable keys" of this manual.

### 2.2.4. Wiring.

All wiring kits described below are optional and have been designed by AEQ to simplify the installation of the unit. To facilitate the quick connection of the console in almost any installation, AEQ can supply audio and data cables with the corresponding DB-type connectors that are used to connect the unit. These cables can be cut to desired lengths and soldered on patch panels, punched into connector strips or fitted with the corresponding connectors to be used directly connected to the peripheral equipment.

- FR-CAB-GPI: DB9 male connector connected to a 4-meter cable with open-end termination, for GPI.

- FR-CAB-GPO: DB9 female connector connected to a 4-meter cable with open-end termination, for opto-coupled GPOs.
- FR-CAB-RELE: DB9 female connector connected to a 4-meter cable with open-end termination, for physical contact (relay) GPOs.
- FR-CAB-MON: DB9 female connector connected to a balanced and shielded four pair, 4-meter cable with open-end termination, for 2 monitor outputs.
- FR-CAB-INP: DB15 male connector connected to a balanced and shielded four pair, 4-meter cable with open-end termination, for 4 audio inputs.
- FR-CAB-OUT: DB15 female connector connected to a balanced and shielded four pair, 4-meter cable with open-end termination, for 4 audio outputs.

AEQ can upon request provide fully finished cables and in special lengths. For more information, please refer to AEQ sales department or authorised distributors.

**IMPORTANT NOTE:** Regarding the wiring, the chassis of microphones must be connected to the chassis of the console frame in order to protect the microphone inputs against uncontrolled static shocks. Pin 1 (Ground) must be connected to the metal case of XLR connector in the available terminal for this purpose, so any static shock will be downloaded to ground through the frame chassis. This rule must be followed in every connector throughout the cable in case of connections by means of aerial connectors. In the same way, for AES3 or USB digital signals, the chassis of PCs or other digital audio devices must be also connected to the chassis of the console frame.

### 3. DESCRIPTION OF THE INTERNAL MENU.

The AEQ FORUM internal menu is displayed on the main screen of the Control and Monitoring section of the control surface.

Most of them allow you to modify the values shown (although some screens of the internal menu are merely informative), changing routing, gains or applying processes to the audio signals. For this purpose, the three rotary encoders and the four contextual keys associated with this screen will be used.

Depending on the information shown on the last line of the menu display, the four contextual keys immediately beneath the display will have different functions. This last line of the menu will have a maximum of four visible options.

The three rotary encoders are associated with the options shown in the menu (each specific screen will be explained in detail later in this manual). The specific association of the encoders is following the next thumb rule: the menu option that is shown farthest to the left or in the highest position is controlled from the encoder located farthest to the left.

The default screen in AEQ FORUM shown in the main Control and Monitoring section display includes the AEQ logo, the product name, the active user and current date and time.



The four options visible on the last line of the display are associated with the four contextual keys below, from left to right:

- **"CLOCK"**: allows you to access to the system date and time configuration menu, as well as to the chronometer and countdown available functions.
- **"LOGOU"/"LOGIN"**: allows you to access to the users registration menu ("LOGIN") or leave the current active user ("LOGOU").
- **"MEMORY"**: allows you to access to the system snapshot memory bank. There are 10 memory positions available in order to store different configurations.
- **"MENU"**: allows you to access to the advanced menu for audio inputs/outputs, routing and processing configuration.

In the upper right part of the display the active user at that moment is shown. For more information, please refer to section **"3.2. LOGIN/LOGOUT menu"** of this manual.

#### 3.1. "CLOCK" menu.

This menu enables you to set the date and time displayed in the system (but not the option of synchronization with an external master clock, which is only configurable from the configuration software: see section 4.2.5 in this manual), as well as activate and control the Chronometer and Countdown functions.

The initial screen shows the current system time (HH/MM/SS) and, up on the right, the date (DD/MM/YY).



The four options visible on the last line of the display are associated with the four contextual keys below, from left to right:

- **"BACK"**: returns to the previous menu screen.
- **"SET"**: enables you to access to the date and time configuration menu. When you access to this menu, the **time configuration** is available (a flashing arrow is displayed next to the current time) by means of using the 3 rotary encoders (turning the first one allows you to change the hour, the second one the minutes and the third one the seconds).

When you press the **"DATE"** contextual key, you access to the **date configuration** menu (the flashing arrow changes its position and the "DATE" changes to **"TIME"**): by pressing the first encoder you can change between day of the week and day of the month and by turning it allows you to change the selected option; you can configure the month by turning the second encoder and the year by turning the third one.

Once date and time are configured, you can press the **"SET"** key in order to save the changes and return to the previous screen or the **"BACK"** key in order to return to that screen without changes saving.



- **"CDOWN"**: lets you configure and activate the AEQ FORUM Countdown option through the associated rotary encoders. The format on screen is HOURS:MINUTES:SECONDS. You can configure the hours by turning the first encoder, the minutes by turning the second one and the seconds by turning the third one. The **"START"** contextual key launches the countdown, the **"STOP"** key (the same key that changes its function) brings it to a stop, and the **"RESET"** key re-establishes the initially configured value (even when the countdown is launched). The **"BACK"** key allows you to return to the previous screen (it also stops the countdown and re-establishes the initial value).



- "CHRONO"**: enables you to configure and activate the chronometer option. The format on screen is HOURS:MINUTES:SECONDS.  
 The **"START"** contextual key initiates the chronometer, the **"STOP"** key (the same key that changes its function) stops it, and the **"RESET"** key re-establishes the initial zero value (even when the chronometer is launched). The **"BACK"** key allows you to return to the previous screen (it also stops the chronometer and re-establishes the initial zero value).



### 3.2. "LOGIN/LOGOUT" menu.

This menu allows AEQ FORUM users/operators to register in the system, so that the equipment recognizes their user level by the associated password, and assigns them an access level for subsequent operation in the different console submenus.

AEQ FORUM allows up to 17 different user levels.

There are 4 user levels defined by default in the console: "ADMINISTRATOR", "ADVANCED", "BASIC" and "NOT LOGGED". The "ADMINISTRATOR" level has all the available permissions. The "NOT LOGGED" level corresponds to a generic user with no associated password, which is accessed by pressing the **"LOGOU"** contextual key in the console's initial menu (that key changes to **"LOGIN"**).

The permissions associated with each user level can be checked in the "User Levels" submenu of the "Forum IP Setup" application. Section 4.1.2 of this manual details this submenu, as well as the process for creating and modifying the system user levels.

The system available users (and the password and user level associated with each of them) can be checked in the "User Configuration" submenu of the "Forum IP Setup" application. Section 4.1.3 of this manual details this submenu, as well as the process for creating and modifying the system users.

The **"LOGIN"/"LOGOU"** contextual key has two possible uses: LOGIN to register yourself (depending on the password used you will access to a certain level) and LOGOUT to de-register (this way you gain access to "NOT LOGGED" user level). When you register through the option **"LOGIN"**, the "PASSWORD" screen appears: six spaces are displayed on screen associated with the six digits (as maximum) of the password. The password must be configured previously from the configuration software (see section **"4. CONFIGURATION SOFTWARE"** of this manual). The password supplied by default for **"Admin"** user ("ADMINISTRATOR" user level) is **1234**.



The procedure for entering the password requires the use of the contextual keys beneath the display and any of the three associated encoders.

By **turning** any of the 3 encoders you can select the desired digit; by **pressing** any of the 3 encoders you can confirm your selection as part of the password and change to the following position (when you press an encoder after selecting the sixth digit, it's equivalent to press the "OK" key).

The four contextual keys are associated with the four options displayed in the bottom line of the display:

- **"BACK"**: pressing this key allows you to return to the previous menu screen.
- **"PREV"**: enables you to move to the left through the six positions that make up the password.
- **"NEXT"**: enables you to move to the right through the six positions that make up the password.
- **"OK"**: allows you to confirm that all the digits of the password have been entered and, if password is correct, change to the associated user (the main display shows then the initial AEQ FORUM screen with the user up on the right and the second contextual key identified as "LOGOU"). When you enter an incorrect combination of digits, a **"WRONG PASSWORD"** message is displayed (the "BACK" key allows you to return to the previous screen in order to insert the password once again).



### 3.3. "MEMORY" menu.

This menu enables you to manage the configuration memories as snapshots. In two consecutive screens, up to 10 memory positions are shown, which are the ones available for storing configurations. For each system user, only the snapshots assigned to that user (or to all users) and the first snapshot (always available) are shown: see section 4.3.5 of this manual.

Each one of these memory positions stores all of the parameters in use at that time in each one of the console channels: gain, phase and balance configuration, "PROGRAM", "AUDITION", "AUX1", "AUX2" and/or "CUE" routing activation, configuration/activation of equalizers, filters and/or dynamics processes and channels activation/deactivation (ON/OFF). No fader position is stored, because these are set manually. The memory position also stores the activation of signals sending to control and studio monitoring (by means of the keys placed under the corresponding displays), but not the position of the 3 associated encoders.

The first of these screens displays the first 4 memory positions, the second shows the following 4 memory positions and the third one the last 2 memory positions. You can shift between these screens by turning any of the associated encoders as you move through the complete list of snapshots stored at that time. The memory that is selected at any time is highlighted.



Each stored memory is identified by its name and the date on which it was created. The names of the memories are editable from the configuration software (see section 4.3.5 in this manual).

The options available through the contextual keys below the screen, from left to right, are:

- **"BACK"**: pressing this key allows you to return to the previous menu screen. No change you may have made is saved.
- **"SAVE"**: stores in the selected memory position the configuration of the console at that moment. The system will ask for your confirmation (in the screen that appears, you can confirm by pressing "SAVE" again or return to the memories list by pressing "BACK").
- **"LOAD"**: allows you to load the configuration you stored previously in the selected memory position. The system will ask for your confirmation (in the screen that appears, you can confirm by pressing "LOAD" or return to the memories list by pressing "BACK").

**IMPORTANT NOTE:** For firmware versions 1.73 of CPU and 1.31 of DSP Router or higher, when a new configuration memory or snapshot is loaded, the audio of the activated channel or channels (ON AIR) will not be interrupted (and the associated routing will remain) provided that in the new memory the activated channels are placed in the same fader positions. The routing toward MPX internal summing buses of any signal will also remain (whether the signal is ON AIR or not).

You can also create snapshots with different configurations from the configuration software. See section 4.3.5 of this manual.

### 3.4. "MAIN MENU".

Pressing the "MENU" key in the initial screen will take you to the "MAIN MENU" screen. From this advanced configuration menu you can control, among other parameters, audio inputs/outputs, internal routing and processes. The four options visible on the last line of the display are associated with the four contextual keys below, from left to right:

- **"BACK"**: pressing this key allows you to return to the previous menu screen.
- **"INFO"**: essentially a maintenance menu displaying information about the IP addresses of the two network ports ("LAN" and "ETHERNET") present in the rear panel of the unit and firmware versions installed in the several console operating modules, as well as the routing and process DSPs percentage of use.
- **"SETUP"**: which displays and allows you to change the IP configuration associated with the two Ethernet ports available on the rear panel of the equipment ("LAN" and "ETHERNET": see section 2.2.2.2 of this manual) in the form of IP address (IP1 or IP2), subnet mask (MASK) and gateway (GWAY). Only level 3 users can modify these parameters (the "SETUP" key is shown to other users but is not active).
- **"SELECT"**: advanced configuration of audio inputs/outputs, internal routing and processes.



### 3.4.1. "INFO" menu.

This is a menu specifically for technical maintenance. The "INFO" menu lets you display the IP configuration associated with the two Ethernet ports available on the rear panel of the equipment ("LAN" and "ETHERNET": IP address, subnet mask and gateway are shown), the firmware versions installed in the several console operating modules and the routing and process DSPs percentage of use.



The three options visible on the last line of the display are associated with three of the four contextual keys below, from left to right:

- **"BACK"**: pressing this key allows you to return to the previous menu screen.
- **"FIRMW"**: in successive screens, which are accessed by turning any of the associated encoders, you can display the firmware versions installed in the different modules that make up the console: the 4 modules that make up the main board of the console (CPU, FPGA, Routing DSP and Process DPS) are shown as "MAIN BOARD" and the MSC module (control and monitoring section) and the FSC modules (4 faders modules or FRCH) are shown as "CONTROL SURFACES".  
Each line is identified by the specific module and its reference, as well as the version and the date of the currently installed specific firmware.

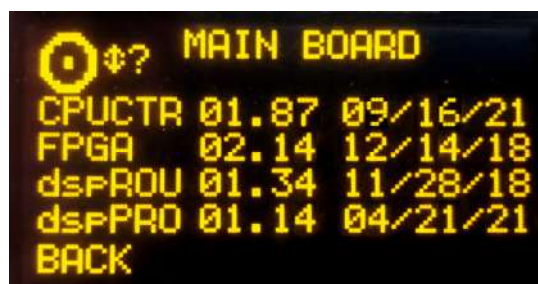

- **"STATUS"**: allows you to access to the information regarding the routing and process DSPs percentage of use. In case the working limit of any of them is exceeded the indication "OVL" (Overload) is shown.

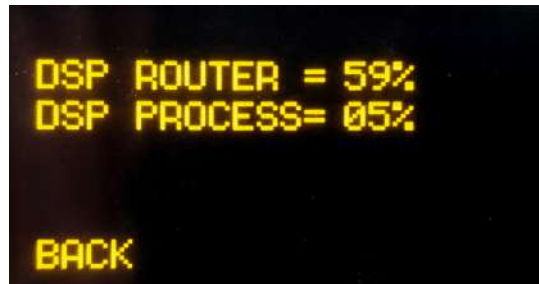

### 3.4.2. "SETUP" menu.

Through the "IPSET" option in a contextual key, this menu enables you to display and modify the IP configuration associated with the two Ethernet ports available on the back panel of the equipment ("LAN" and "ETHERNET": see section 2.2.2.2 of this manual) in the form of IP address, subnet mask (MASK) and gateway (GWAY). Only level 3 users are allowed to modify these parameters (the "SETUP" key is shown to other users but is not active).

**IMPORTANT NOTE: the IP addresses of both Ethernet ports must not be configured into the same network.** For instance, if "LAN" port is configured with 172.31.34.1 IP address and 255.255.0.0 mask, the IP address of the "ETHERNET" port should be different from 172.31.x.x (where x is any number between 0 and 255).

As in many other AEQ FORUM console submenus, the icon in the upper left-hand corner indicates that browsing and configuration are performed by using the associated rotary encoders.

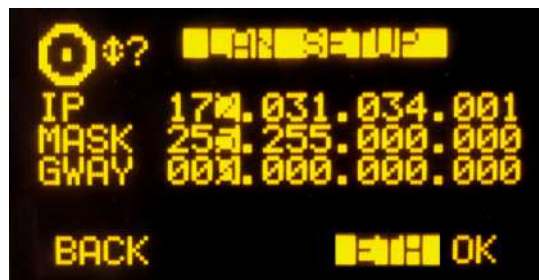

From left to right, the three rotary encoders are associated with "IP", "MASK" and "GWAY" fields respectively. Each one of these fields consist of 4 number separated by dots and named bytes.

A flashing cursor indicates the byte that is subject to be changed at that moment by turning the associated encoder. Pressing any of the 3 encoders allows you to change from one byte to the next one. This process is repeated from left to right until the IP address is complete, as well as the associated subnet mask and gateway.

The "OK" contextual key allows you to validate and save the changes, returning then to the previous screen. The "BACK" contextual key allows you to return to the previous screen without changes saving.

The "ETH"/"LAN" contextual key allows you to alternate the on-screen presentation and, therefore, to edition of the IP configuration parameters associated with the two network ports available on the rear panel of the unit: "LAN" and "ETHERNET".

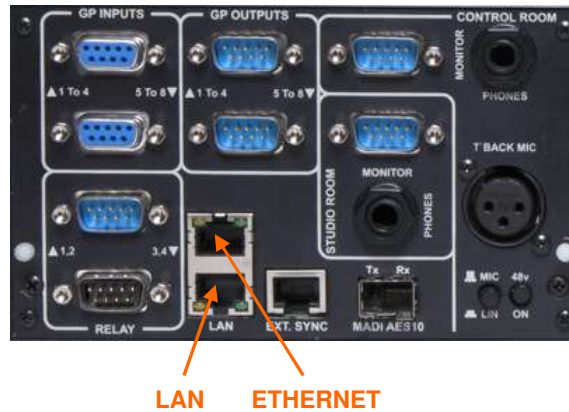

### 3.4.3. "SELECT" menu.

This menu enables you to perform advanced configuration operations on audio inputs/outputs, processes and internal routing of all of the signals present in the console.



The options available through the contextual keys below the screen, from left to right, are:

- **"BACK"**: pressing this key allows you to return to the previous menu screen.
- **"INPUT"**: configuration of input audio signals, as well as processes and routing associated with those signals.
- **"OUTPUT"**: configuration of output audio signals, as well as associated routing and tones activation.

#### 3.4.3.1. "INPUT" menu.

This menu shows a list of all the audio input logical signals defined in the system from the configuration software. For more information, see section **"4. CONFIGURATION SOFTWARE"** in this manual.



You can access a more complete description of each one of the input audio channels by turning any of the 3 associated encoders and pressing then the "OK" contextual key or any of these encoders. The information showed on this screen, from top to bottom and left to right, is:

- **Name of the channel**, in alphanumeric format containing up to 6 characters. This is the same identifier as the one shown in the channel display. See section "2.1.1.3. Channel display" in this manual.



- **Hardware** corresponding to the audio input of this channel, in format HW: xx.yy, where xx is the number of the slot where this inputs/outputs module is installed, and yy is the audio channel of this inputs/outputs module. In stereo channels, yy represents the audio channel corresponding to the left channel of the stereo pair. The right channel corresponds to the number just above.
- Graphic representation of three **encoders** associated with the **GAIN**, **PHASE** and **BALANCE** fields. By operating on the rotary encoders associated with the main screen in the Control and Monitoring section, you can change the values.
  - **GAIN**: configurable between -12dB and +12dB for line level inputs and between -36dB and +19dB for mic level inputs. The field is configured with the default value of 0dB. Any modification of the initial value of this gain will illuminate the dedicated "**GAIN**" LED on the corresponding fader of the control surface (see section "2.1.1.5. Indicators of active processes" of this manual).
  - **PHASE**: allows you to modify the input signal phase among +/+, +/-, -/+ and -/- for stereo signals, and among + and - for mono signals.
  - **BALANCE**: enables you to modify the balance between the L and R channels in stereo signals. The operation of this indicator will activate the dedicated "**BAL**" LED on the corresponding fader of the control surface (see section "2.1.1.5. Indicators of active processes" of this manual).

**By pressing this encoder**, you can configure the sending mode of the stereo input signal toward the stereo outputs that it is routed to. The options that appear successively when you press the encoder are: **L-L** (only the L input channel is sent to L and R output channels), **R-R** (only the R input channel is sent to L and R output channels) and **R-L** (the R input channel is sent to the L output channel and the L input channel is sent to the R output channel). If you press the encoder once more, it returns to the normal working mode (**L-R**).

**NOTE:** When the input audio channel selected in the "INPUTS" list is assigned to a fader channel, you can also access to this advanced information screen by pressing the "**SELECT**" key of the corresponding channel (see section "2.1.1.2. SELECT" of this manual), working this key as a quick access to this submenu. Using any of both access ways, the LED of the "SELECT" will be activated.

The four contextual keys under the display are associated with the four options shown in the bottom line of the screen:

- "**BACK**": pressing this key allows you to return to the previous menu screen.
- "**DYNAM**": allows you to access to the menus for configuration and activation of dynamics effects included in AEQ FORUM: Compressor/Limiter and Noise Gate.
- "**EQUAL**": allows you to access to the menu for configuration and activation of Equalizers and Filters included in AEQ FORUM.
- "**NEXT**": allows you to access the additional information menu about the audio signal present in this input channel, where you can also change the signal assigned to that channel and modify its internal routing.

### 3.4.3.1.1. Dynamics menu: Compressor/Limiter and Noise Gate.

#### COMPRESSOR / LIMITER:

Pressing the "**DYNAM**" contextual key from the advanced information menu of an audio input channel will give you access to the menu to configure the Compressor/Limiter.

Dynamics processors are used to modify the dynamic ranges of an audio signal to adapt it to specific needs or to produce certain sound effects. A compressor enables you to reduce the dynamic range of the signal. Your purpose may be to adapt a signal with a very broad dynamic range to a circuit that will not support such wide variations in level, or to generate certain sonority in a signal.

The "**Compressor / Limiter**" function acts as a "constant gain" compressor; that is, below the threshold, all input signals are amplified (or not amplified) equally, while above the threshold, the input levels are reduced to a greater or lesser degree according to the compression ratio.

If the compression range selected is the maximum, the function will act as a limiter in such a way that the signals that exceed the selected threshold at input will not exceed a certain level at output. For example, with a threshold = 0 dB, a gain of 10 dB and a compression ratio of 1:50, you will ensure that all the signals that exceed 10 dB at input will also be output at 10 dB, while the signals that are below the threshold will have an overall gain of 10 dB.



From top to bottom and left to right, the information displayed on the Compressor/Limiter configuration and control screen comprehends:

- **"THR" (Threshold):** this is the threshold above which the compressor will act. Signal levels that exceed this threshold will be affected by the compressor settings. The threshold range varies from -42dB to +22dB.
- **"ATT" (Attack Time):** this is the time it takes the compressor to react to an increase in the input signal. The shorter this time, the more sensitive the compressor will be to pulse signals, and the higher the action on this type of signals. With a long attack time, the compressor will not respond so well to pulse changes in the input signal. It ranges between 0.5 and 95 ms.
- **"REL" (Release Time):** this is the maintenance time during which the compressor keeps acting, even when the level of the input signal has fallen below the threshold. A long release time will maintain uniform compression, even when there are quick level fluctuations in the signal. A short time will enable the compressor to adapt more quickly to pulse fluctuations in the signal. It ranges between 10 and 9500 ms.
- **"RAT" (Compression Ratio):** this is the compression ratio. A ratio of 1:1 does not involve any variation in the signal, as the level of the input signal is maintained at the output. A ratio of 2:1 indicates that the level of an input signal which exceeds the threshold will be reduced to half at the output. The highest ratio available is 50:1, which will be used to implement signal limiters. The limiter must reduce all signals exceeding a certain level to that level.
- **"G" (Gain):** this enables you to apply a general gain to the signal. This entails a general increase of the signal level, which will be especially noted at low input levels that are under the threshold set. A general increase in the level of the signal may generate saturation at the output, even when the signal is being limited. It ranges between 0 and +40dB.

A cursor blinks over the fields placed on the left or on the right to indicate the fields that can be modified at that moment. To change from the one to another just press any of the three associated encoders. When you select the fields on the left, turning the first encoder allows you to change "THR", the second one changes "ATT" and the third one changes "REL"; when you select the fields on the right, turning the first encoder allows you to change "RAT" and the second one changes "G" (the third one has no function in this case).

NOTE: To correctly set a limiter, a threshold between 0 and +22 dB should be selected, with a compression ratio of 50:1 and a gain of 0 dB.

The "**COMP**" contextual key enables you to activate the compressor whose parameters are shown at that time on the screen. The activation of the compressor is confirmed by the activation of the **LED** of the contextual key and the **LED "DYN"** of the selected mixer channel (see section "**2.1.1.5. Indicators of active processes**" of this manual). The "**COMP**" contextual key also enables you to return to the Compressor/Limiter menu when you are in the Noise Gate menu (in that case, the associated LED lights for a moment and then it turns off).

IMPORTANT NOTE: The dynamics process, and especially the Compressor/Limiter, requires either extensive experience or caution and time to check, while off the air, the result obtained on the signal. Without these precautions, you may generate sound effects that can be perceived as dirty sound, lack of definition, distortion and other defects in general.

By pressing the "**NGATE**" contextual key you will access the screen dedicated to the control and configuration of the Noise Gate for that input channel (the associated LED lights for a moment and then it turns off).

#### NOISE GATE:

A noise gate is a dynamics processor that lets signals through whose level exceeds a certain threshold, strongly attenuating the signal levels below that threshold and thus muting noise. It enables its user to eliminate extraneous noise from a signal source, whether it is background noise in the studio, in the case of a microphone, or the background noise generated by a playback device, for example, a tape.

From top to bottom and left to right, the information shown in the Noise Gate configuration and control screen is as follows:

- "**ATT**": Attack Time. It ranges between 0 and 95 ms.
- "**REL**": Release Time. It ranges between 0 and 9000 ms.
- "**HOL**": Hold Time. It ranges between 0 and 2000 ms.
- "**THR**": Threshold. It ranges between -72 and 0dB.
- "**R**": Range. It ranges between 0 and 90dB.



A cursor blinks over the fields placed on the left or on the right to indicate the fields that can be modified at that moment. To change from the one to another just press any of the three associated encoders. When you select the fields on the left, turning the first encoder allows you to change "ATT", the second one changes "REL" and the third one changes "HOL"; when you select the fields on the right, turning the first encoder allows you to change "THR" and the second one changes "R" (the third one has no function in this case).

When establishing the settings, the threshold for the noise gate will be much lower than in the case of the compressor, as its operation is the opposite. The noise gate prevents the passing of lower levels of the signal that could be considered noise. Therefore, the range of settings is different. In addition, there is an additional parameter for noise gates, which is "Hold Time." This is a safety period used to prevent the gate from accidentally closing if a signal is suddenly absent, for example, in speech.

In addition, the threshold must be adjusted to a level slightly higher than the level of the noise to be avoided. Thus, the threshold will be set at a very low level. Above the threshold, the noise gate does not act (unity gain), letting the rest of the signal through without processing it. The gate remains closed; i.e. when the signal surpasses the threshold level, the gate opens. The attack time is the time the gate takes to open (unity gain) when it receives a signal whose amplitude exceeds the threshold level; this time must be short to avoid cutting off the beginning of a sentence or song. The release time is the time the gate takes to close when the signal level falls below the threshold. The hold time is the minimum time during which the gate remains open; it is used to prevent the gate from closing when the signal level drops briefly—for example, when an announcer pauses while speaking. The hold time prevents the gate from opening and closing constantly in the presence of a signal whose level fluctuates in a range close to the threshold level.

The **"NGATE"** contextual key enables you to activate the noise gate whose parameters are shown at that time on the screen. The activation of the noise gate is confirmed by the activation of the **LED** of the contextual key and the **LED "DYN"** of the selected mixer channel (see section **"2.1.1.5. Indicators of active processes"** of this manual). The **"NGATE"** contextual key also enables you to return to the Noise Gate menu when you are in the Compressor/Limiter menu (in that case, the associated LED lights for a moment and then it turns off).

#### 3.4.3.1.2. Equalizer and filter menu.

Pressing the **"EQUAL"** contextual key from the advanced information menu of an audio input channel will give you access to the menu to configure the equalizer and filters.

The upper part of the screen shows the channel identifier name and the middle area of the screen shows the graphic representation of the response curve of the equalizer and filters that are active at that time.



The four options visible on the last line of the display are associated with the four contextual keys below, from left to right:

- **"BACK"**: pressing this key allows you to return to the previous menu screen.
- **"HPF"**: allows you to activate the configured high pass filter (the associated LED will light). Pressing this contextual key for three seconds opens the cut-off frequency configuration menu: this configuration is accomplished by turning the first associated encoder and pressing the "BACK" contextual key to return to the previous screen once this parameter is configured (between 20 and 1000Hz).



- **"LPF"**: allows you to activate the configured low pass filter (the associated LED will light). Pressing this contextual key for three seconds opens the cut-off frequency configuration menu: this configuration is accomplished by turning the first associated encoder and pressing the "BACK" contextual key to return to the previous screen once this parameter is configured (between 1000 and 20000Hz).



- **"EQ"**: allows you to activate the equalizer whose frequency response is shown at that time on the screen (the associated LED will light). This frequency response is controlled from the associated encoders by working from left to right on the base, mid-range and treble bands, respectively. The frequency deviation permitted ranges from -18dB to +18dB (the default value is +0dB). Pressing this contextual key for three seconds opens the equalizer advanced configuration menu, where 3 rows appear for base ("LOW"), mid-range ("MID") and treble ("HIG") bands respectively. You can change from one band to another by pressing any of the three associated encoders. In the selected band (a flashing arrow is displayed), you can change the **central frequency** ("F(Hz)" column) by turning the first encoder, the **Q** ("Q" column) by turning the second encoder and the **gain** ("G(dB)" column) by turning the third encoder. The "HPF", "LPF" and "EQ" contextual keys in this screen allows you to activate filters and equalizer; the "BACK" key allows you to return to the graphic configuration screen.

### 3.4.3.1.3. Expanded information menu.

Pressing the **"NEXT"** contextual key from the advanced information menu of an audio input channel will give you access to the advanced information section of that channel. It maintains a structure similar to the base menu. Information shown on this screen:



- **Name of the channel**, in alphanumeric format containing up to 6 characters. This is the same identifier as the one shown in the channel display. See section "2.1.1.3. Channel display" in this manual.
- **Hardware** corresponding to the audio input of this channel, in format HW: xx.yy, where xx is the number of the slot where this inputs/outputs module is installed, and yy is the audio channel of this inputs/outputs module. In stereo channels, yy represents the audio channel corresponding to the left channel of the stereo pair. The right channel corresponds to the number just above.
- **Channel type**: mic/line, analogue, digital, USB, MADI or AoIP.
- Indication of **MONO** or **STEREO** signal.
- In **mic/line** channels, indication of the position of the switch that selects the nominal level of the signal as mic or line (located in the relevant input module on the back panel of the unit). It changes from "MIC" to "LINE" and vice versa when you change the switch position.
- In **mic/line** channels configured as mic, indication of the position of the phantom power switch (located in the relevant input module on the back panel of the unit). It changes from "PHANTOFF" to "PHANTON" and vice versa when you change the switch position.

The contextual keys under the display are associated with the three options shown in the bottom line of the screen:

- **"BACK"**: pressing this key allows you to return to the previous menu screen.
- **"CFG"**: allows you to configure the mic/line channels as microphone or line and to activate/deactivate the Phantom power. This option only appears for that type of channels when the edition of the common I/O's module or the Mic/Line inputs module (FR03S) doesn't include selectors to accomplish that configuration.
- **"FADER"**: allows you to assign another input channel to the physical fader where this signal is currently found.
- **"ROUTE"**: gives you access to the menu for control and configuration of the internal routing of the equipment.

#### 3.4.3.1.3.1. "CFG" menu.

This menu only appears in **mic/line** channels and it allows you to configure those channels as microphone or line and to activate/deactivate the Phantom power. It only appears when the edition of the common I/O's module or the Mic/Line inputs module (FR03S) doesn't include selectors to accomplish that configuration.



The operation of the contextual keys, from left to right, is as follows:

- **"BACK"**: pressing this key allows you to return to the previous menu screen.
- **"M/L"**: when the channel is configured as microphone enables you to change it to line and vice versa. When pressed the configuration is changed and it returns to the previous screen.
- **"PHM"**: when the Phantom power is deactivated enables you to activate it and vice versa. When pressed the configuration is changed and it returns to the previous screen. This key is only operative when the channel is configured as microphone.

**Mic/Line inputs** are configured as microphone with no Phantom feed by default.

### 3.4.3.1.3.2. "FADER" menu.

This submenu is displayed as a list of all the inputs available in the system (except the ones that are yet assigned to a fader) and allows you to assign another input signal to the selected channel. It is also possible to access this menu by means of a long press (more than 2 seconds) of the "SELECT" key of the channel.

You can make your selection by turning any of the associated encoders and then pressing any of them or the "OK" contextual key to confirm the selection that is highlighted at that moment. The "BACK" contextual key allows you to return to the previous menu screen without changed the assigned signal.

### 3.4.3.1.3.3. "ROUTE" menu.

From this internal submenu you can manage the internal routing of signals in the console. You can access from the advanced information menu of an audio input channel and that submenu shows an alphabetical list of all of the outputs present in the console, followed by the internal summing buses ("Program", "Audition", "Aux1" and "Aux2"), the monitoring buses ("Cue", "Studio" and "Control") and finally the MPX buses.

The operation of the three associated encoders is as follows:

- Left: turning this encoder allows you to scroll through the several audio outputs and buses on the list. Pressing this encoder allows you to return to the previous menu screen (the changes you may have made are saved).
- Centre: turning this encoder has no associated function. Pressing this encoder allows you to return to the previous menu screen (the changes you may have made are saved).
- Right: turning this encoder enables you to modify the gain in the cross-point of the highlighted output or bus between -99.8dB and +24dB. By default, all of the cross-points will be configured with a 0dB gain. Pressing this encoder allows you to return to the previous menu screen (the changes you may have made are saved).



The operation of the contextual keys, from left to right, is as follows:

- **"BACK"**: pressing this key allows you to return to the previous menu screen (the changes you may have made are saved).
- **"ADD"**: enables you to create the cross-point toward the output signal or bus that is highlighted at that moment.
- **"DEL"**: enables you to delete the cross-point toward the output signal or bus that is highlighted at that moment.
- **"OK"**: pressing this key allows you to return to the previous menu screen (the changes you may have made are saved).

The routing toward the "Program", "Audition", "Aux1" and "Aux2" internal buses works in a different way depending on the assignment of the selected input to a fader or not:

- when the input is assigned to a fader and, in the previous list, you select "Program" bus (for instance), when you press the "ADD" key the routing key ("PROGRAM" in this case) of the channel is activated (the associated LED is lighted). In the display, the cross-point toward that bus appears for a moment and then disappear. The "DEL" key has no associated function in that case (you must press the "PROGRAM" channel key to deactivate that routing). If now you press the "ON" key of the channel, the cross-point appears now in the display (if you rise the fader, the "ON AIR" indicator will light); in that case, the "DEL" key allows you to deactivate the routing toward that bus (the cross-point disappear and the "PROGRAM" channel key turns off).
- when the input is not assigned to a fader and, in the previous list, you select "Program" bus (for instance), pressing the "ADD" key is equivalent to set that input "ON AIR" (the cross-point appears and, if gain is not configured at its minimum value, signal is sent to that bus). The "DEL" key allows you to deactivate that routing (the cross-point disappears).

It is possible to configure the operation mode of the sends to the internal summing buses in two ways, depending on whether the **"Pre-fader Sends"** option is activated or not (see section **4.2.8 "Options" submenu**). When this option is deactivated, the send level of a certain input to the system buses is linked to the fader, so that the variation of the channel fader affects those sends. When that option is activated, it's possible to unlink any of those sends from the channel fader; for this, the central encoder of the three located under the main display is used: by pressing it that send is activated/deactivated as pre-fader (when activated it is indicated by an arrow to the right inscribed in the cross point).



In the example, the send from "MIC 6" input to the summing bus "Aux 1" is linked to the fader (there is no arrow in the cross point) and the send to "Aux 2" is pre-fader (there is an arrow in the cross point).

### 3.4.3.2. "OUTPUT" menu.

This menu shows a list of all the audio output logical signals defined in the system from the configuration software, followed by the internal summing buses ("Program", "Audition", "Aux1" and "Aux2"), the monitoring buses ("Cue", "Studio" and "Control") and finally the MPX buses. For more information, see section **"4. CONFIGURATION SOFTWARE"** in this manual.

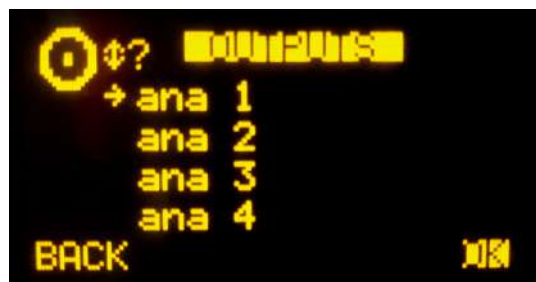

You can access a more complete description of each one of the output audio channels by turning any of the 3 associated encoders and pressing then the "OK" contextual key or any of these encoders. The information showed on this screen, from top to bottom and left to right, is:

- **Name of the channel**, in alphanumeric format containing up to 6 characters.
- **Hardware** corresponding to the audio output of this channel, in format HW: xx.yy, where xx is the number of the slot where this inputs/outputs module is installed, and yy is the audio channel of this inputs/outputs module. In stereo channels, yy represents the audio channel corresponding to the left channel of the stereo pair. The right channel corresponds to the number just above.
- Graphic representation of an **encoder** associated with the **GAIN** field. By turning the first associated encoder, you can configure gain between -12dB and +12dB. The field is configured with the default value of 0dB.
- Indication of audio signal type: analogue, digital, USB, MADI or AoIP.
- Indication of **MONO** or **STEREO** signal.



The contextual keys under the display are associated with the three options shown in the bottom line of the screen:

- **"BACK"**: pressing this key allows you to return to the previous menu screen. The gain configuration you may have made is saved. You can also return to the previous screen by pressing any of the three associated encoders.
- **"TONE"**: controls the 1KHz calibrated tone generator associated with that physical output. Its activation is identified through the **LED** of the contextual key. To modify its level, you need only to change the output gain associated with that channel from the rotary encoder associated with "GAIN" control.
- **"ROUTE"**: this submenu allows you to manage the internal routing of the signals in the console toward that output signal or bus. It is displayed as a list of all the inputs channels connected to that output at that moment. By turning the first encoder you can go round the cross-points list. You can activate or deactivate the selected routing by means of "ADD" and "DEL" contextual keys and you can modify the cross-point gain (between -99.8dB and +24dB) by turning the third encoder.



#### 4. CONFIGURATION SOFTWARE.

The AEQ FORUM IP console is ready for use once the mixer inputs and outputs have been properly connected.

The console is shipped with the Audio inputs/outputs modules as requested by each customer. However, the name tags used for the channel audio inputs and outputs are generic (MIC 1, ANA 3, DIG 5 ...) and routing and effects programmed are AEQ standards that are used for functional testing of the console, whereas these settings may not be entirely to the preferences of the client.

This equipment is delivered with a Configuration Software for Windows 2000, XP, Vista, 7, 8, 10 and 11.

This configuration software allows the user to modify the original configuration to its exact requirements at any time.

The auto run USB key furnished with the console contains the executable file that installs the configuration software. You can find it going through the following screens:



Installing the application is simply a matter of executing this file and following the on-screen instructions as they come up.

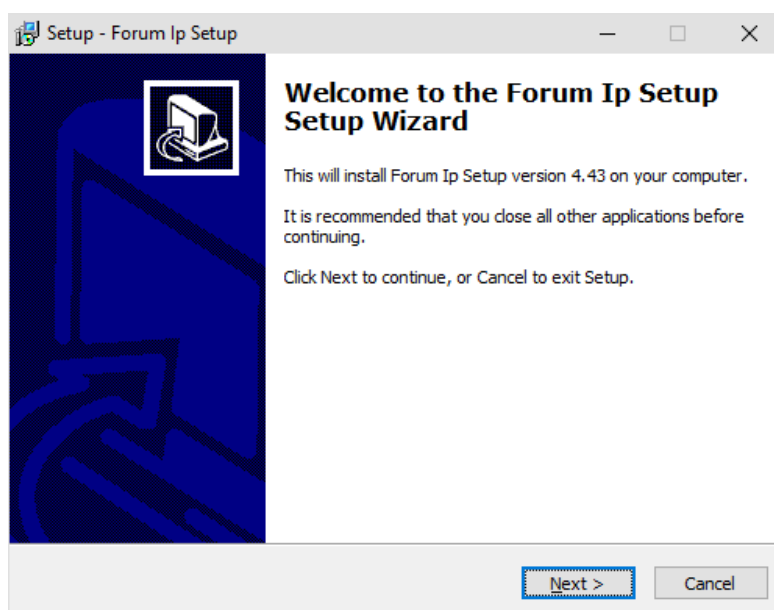

Once the "**Forum IP Setup**" application is installed (by default, in C:\Program files \ForumIpSetup), you can start it up by double-clicking the icon displayed on the desktop:



The configuration program will also be accessible from the Start menu. This version of the application is valid also for **AEQ FORUM IP SPLIT**.

**IMPORTANT NOTE:** In addition to the one corresponding to AEQ FORUM IP, there is another edition of the board that form the control and monitoring section also with the control VU meters and the programmable keys placed in vertical position: for that board edition there is a specific version of the application (**Forum V2 Setup**) with the programmable keys placed that way. On the other hand, the initial edition of AEQ FORUM console has also a specific version of the application (**Forum Setup**). The auto run USB key furnished with the unit contains the software version corresponding to the specific hardware of the console. V2 version is installed by default in C:\Program files \ForumV2Setup and the icon on the desktop indicates V2; version associated to the initial hardware is installed by default in C:\Program files \ForumSetup:

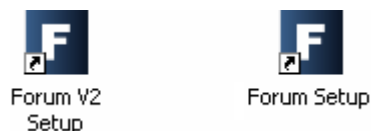

When the application starts up, the access screen will appear asking user to introduce name and password.



Only the users defined as administrators ("ADMINISTRATOR" access level) can access to this application. User and password supplied by default are:

**Login: ADMIN**  
**Password: 1234**

You may modify these parameters later in the "Administration" → "User Configuration" menu of the application. Please refer to section 4.1.3 of this manual.

After entering the correct user-name and password, the program shows the main-screen where you can access the different options.

There are two main areas in this workspace:

- Left side of the screen: pull-down menus and submenus area.
- Right side of the screen: larger area containing parameter settings for each of the menus and submenus.



This initial screen shows information regarding the software version and the current user logged into the application. On the left side of the screen all the relevant menus and submenus are available. These are drop-down menus and are activated by clicking on the desired option.

The list of available menus is:

- **"Administration"**: allows you to manage the user levels and the authorized users of the mixing console and control the communication between the remote configuration software and the mixer.
- **"Hardware Configuration"**: allows you to configure the physical audio inputs and outputs modules that are installed in the mixer and the logical audio channels that are created based on these. Further, the configuration of the monitoring sections, the "Visual Radio" functionality, the time synchronization, the vumeters transmission mode and the operation mode of the sends to the summing buses and of the channel activation keys are accomplished from here.
- **"Programmable Configuration"**: allows you to configure the internal routing of audio signals and the functions associated with the programmable keys, as well as define mics groups, create processes presets and manage the configuration memories (snapshots) of the unit.
- **"Firmware Upgrade"**: is a maintenance menu to accomplish future firmware upgrades of the mixer.

To exit the application, simply press the exit icon located in the upper right corner of the screen. The application will ask for confirmation.

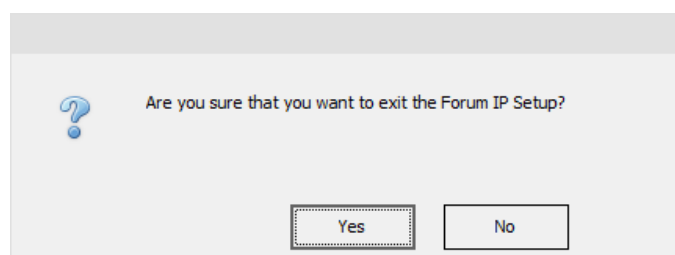

#### 4.1. "Administration" menu.

This menu allows you to manage levels of users that can operate the mixer and control the communication between the remote configuration software and the mixer. Clicking on the "Administration" section of the main screen the complete list of submenus is shown:

- **"Configurations"**: allows you to manage the configuration exchange between the software application and the connected AEQ FORUM mixing console.
- **"User Levels"**: allows you to define the user levels to operate the AEQ FORUM mixing console.
- **"User Configuration"**: allows you to define the users with access to operate the AEQ FORUM mixing console.
- **"About Forum IP Setup"**: this screen shows information regarding the software version and the current user logged into the application.

##### 4.1.1. "Configurations" submenu.

"Configurations" submenu is accessed, from the drop-down menu "Administration", by clicking on the icon:



"Configurations" submenu handles the exchange of configurations created in the software application between this software and the AEQ FORUM mixer.

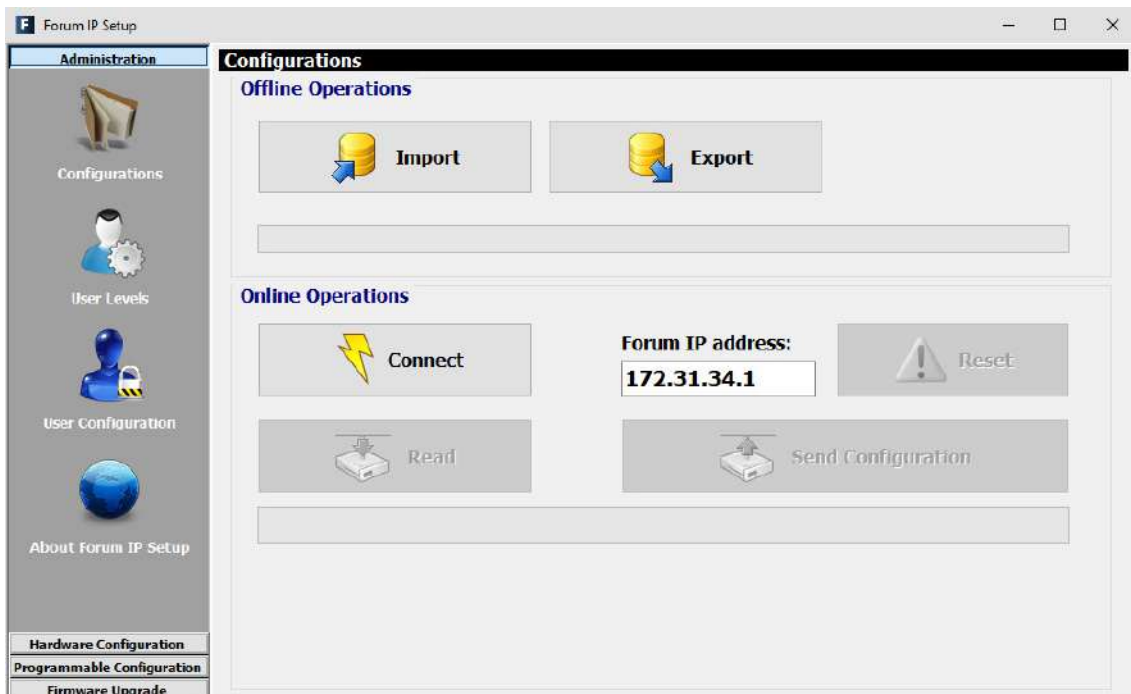

There are two distinct areas in this submenu:

- **"Offline Operations"**: allows you to execute actions where it is not necessary that the "Forum IP Setup" application is in direct communication with the AEQ FORUM mixer. These actions are available:

- **"Import"**: allows you to load in the application complete configurations previously stored in a source file. By clicking the "Import" button, a standard Windows "browse for file" window will open to locate the file to import. The files must be of the proprietary type **FSC** (Forum Setup Configuration). These files are encrypted for reasons of security.

You can find the "DemoConfiguration.FSC" file in C:\Program files \ForumSetup\Demos.

**IMPORTANT NOTE:** when you load a configuration using this option, the active configuration at that moment in the application is overwritten and get lost (unless you previously save it by means of "Export" option). Therefore, you will be asked for confirmation:

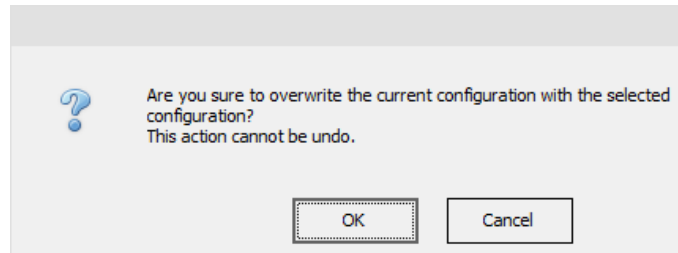

- **"Export"**: allows you to download the complete configuration, as shown in the application at any given moment, to a target file. Clicking on the "Export" button a standard Windows "save as" window will open allowing you to choose the folder and output file name to be stored. These files will have the **FSC** extension.
- **"Online Operations"**: allows you to execute actions where it is necessary that the "Forum IP Setup" application is in direct communication with the AEQ FORUM IP mixer, which "LAN" port, located on the rear panel of the mixer, has the default IP address displayed on the screen. When the connection is made through the "ETHERNET" port, the default IP address is 172.26.34.1.

The "Connect" button initiates the communication process between the "Forum IP Setup" application and the AEQ FORUM IP Mixer. If the connection is established correctly the 3 associated buttons become active and the "Connect" button changes to "Disconnect" (and allows you to end that communication).

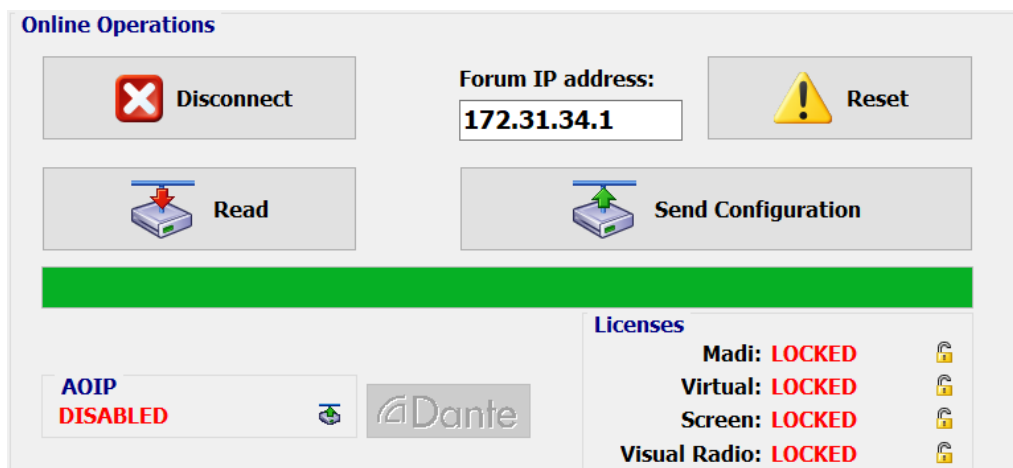

In case there is no connection to the mixer, those options are not activated and the following message is displayed:



The associated buttons functions are the following ones:

- **"Read"**: allows you to read the configuration currently active in the AEQ FORUM mixer and download it in the "Forum IP Setup" application.

**IMPORTANT NOTE 1:** the active configuration at that moment in the application is overwritten and get lost (unless you previously save it by means of "Export" option).

**IMPORTANT NOTE 2:** for firmware versions 1.73 of CPU and 1.31 of DSP Router or higher, the routing toward MPX internal summing buses is saved on console configuration and it will appear in the "Routing Configuration" submenu when the active configuration is read.

- **"Send Configuration"**: allows you to send the currently selected configuration to the AEQ FORUM mixing console, thus becoming the valid configuration in operation. The audio will be interrupted a few seconds while the new configuration is being activated. During the sending, a bar shows the process. If the process is properly done, the message **"Send Configuration: OK"** is displayed.
- **"Reset"**: replaces the currently active configuration on the AEQ FORUM mixing console with the configuration stored in the first memory or snapshot defined (please refer to section 4.3.5 of this manual). It is equivalent to "LOAD" that first snapshot from "MEMORY" menu of the console (see section 3.3). The audio will be interrupted a few seconds while the new configuration is being loaded (unless in that first memory the ON AIR channel or channels are placed in the same fader positions).
- **"AOIP"**: allows you to active at physical level the AoIP (audio over IP) function. When you press the associated button, a window will appear allowing you to configure the maximum number of channels that could be activated: 32 (1 FR14 module) or 64 (2 FR14 modules).

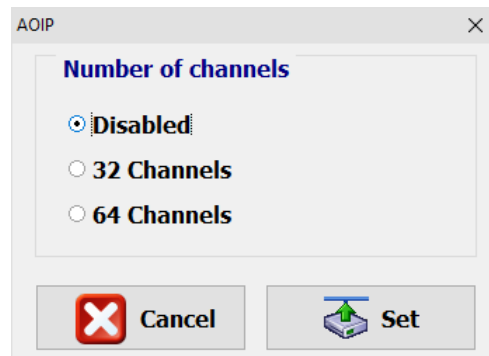

Once activated, it is shown like this:

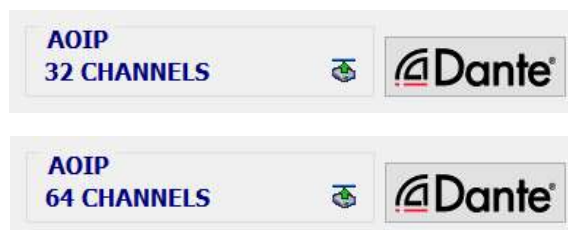

The **"Dante"** button gives you access to the unit's AoIP module configuration (see section 4.1.1.1 of this manual).

- **"Licenses"**: allows you to activate the MADi link and/or the "Forum Virtual" and "Forum Screen" applications functionality, as well as the "Visual Radio" functionality. For any of the 4 options, you must purchase a user license.

When you press the padlock associated with any of the 4 options, a window will appear allowing you to introduce the key associated with the corresponding functionality.

For MADI functionality:

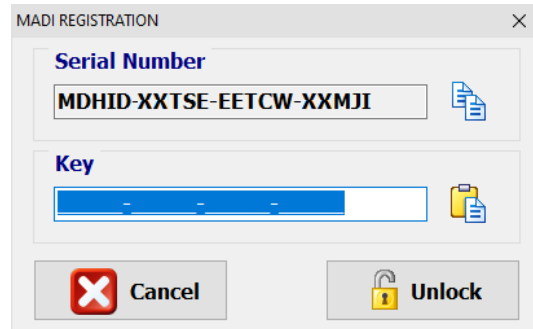

MADI REGISTRATION

**Serial Number**  
MDHID-XXTSE-EETCW-XXMJI

**Key**

Cancel Unlock

for the "Forum Virtual" application:

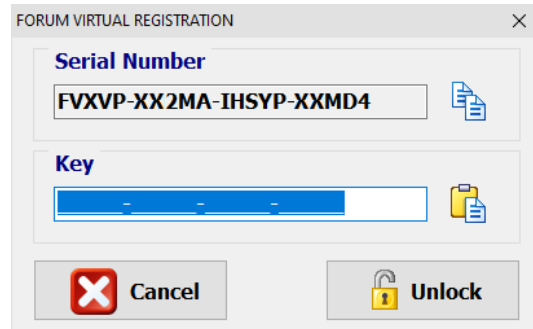

FORUM VIRTUAL REGISTRATION

**Serial Number**  
FVXVP-XX2MA-IHSYP-XXMD4

**Key**

Cancel Unlock

for the "Forum Screen" application:

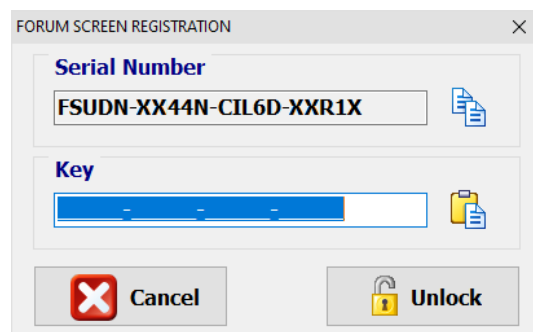

FORUM SCREEN REGISTRATION

**Serial Number**  
FSUDN-XX44N-CIL6D-XXR1X

**Key**

Cancel Unlock

or for the "Visual Radio" functionality:

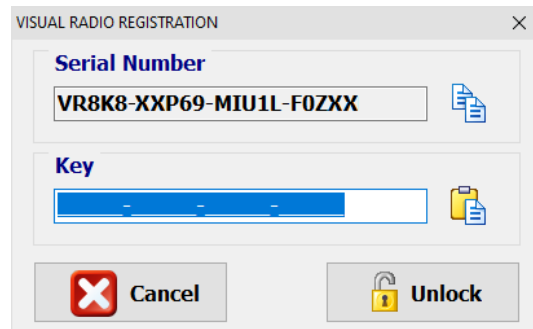

VISUAL RADIO REGISTRATION

**Serial Number**  
VR8K8-XXP69-MIU1L-F0ZXX

**Key**

Cancel Unlock

In case your order includes any of those functionalities, the console is supplied from Factory with the functionality activated. If you want to activate it a posteriori, you must copy the "Serial Number" by means of the associated button and send it to AEQ in order to generate the associated "Key" and send it back to you (you must paste it by means of the associated button).

The "Unlock" button allows you to confirm the key and, when it's correct, activate the function.

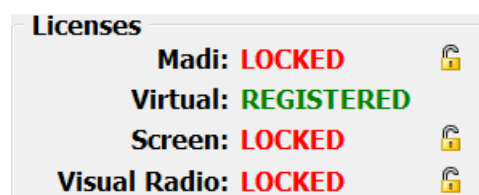

**Licenses**

Madi: **LOCKED**

Virtual: **REGISTERED**

Screen: **LOCKED**

Visual Radio: **LOCKED**

In case the key is not the right one, a warning message will appear:



**IMPORTANT NOTE: MADI** functionality is not compatible with **AoIP** (audio over IP) functionality, both options can't be active at the same time.

#### 4.1.1.1. Dante Configuration.

The "Dante" button gives you access to the configuration window of the unit's AoIP module. Please note that if "Dante Controller" or "Dante Firmware Update Manager" applications are not installed on the PC, this button appears disabled and, below it, the indication "DanteDiscovery service not found" is shown in red.



This option allows you to configure the device/s name at Dante level.

It also allows you to rename the transmission and reception channels of the AoIP module/s with the names of the logical channels defined in the "I/O Configuration" submenu (see section 4.2.3 of this manual). If any line is configured as stereo, at Dante level the 2 associated lines will be renamed with the L and R ending.

Finally, this option also allows you to modify the clock configuration at Dante level, taking into account the way that the device's synchronization is configured at local level.

When you press the "Dante" button, the following window appears:

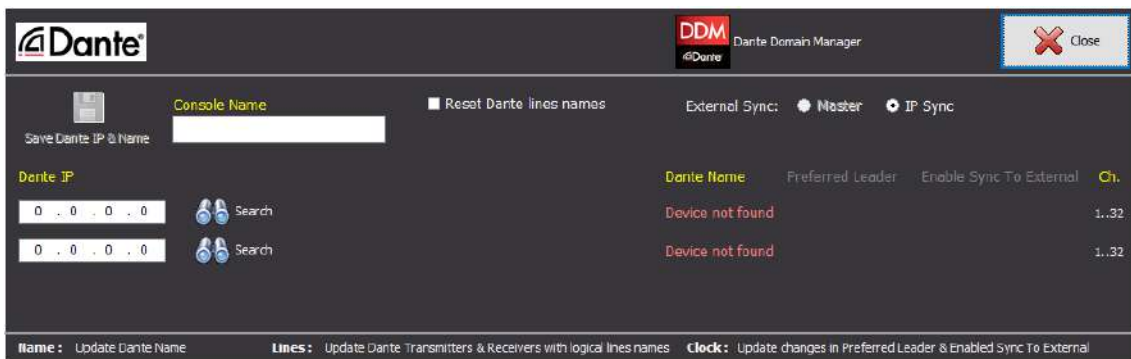

In case there's only one AoIP module configured, only the first line will appear:



The first thing to do is configure the IP addresses of the Dante modules in the “Dante IP” fields and press the associated “Search” button.

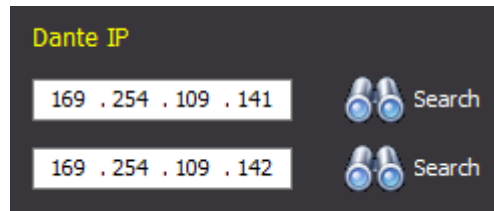

When connection to the first Dante module (the one installed in slot 14) is established, the previous window changes to:



When connection to the second Dante module (the one installed in slot 13) is established, the previous window changes to:



**IMPORTANT NOTE:** If changes are made to the AoIP module/s from the "Dante Controller" application (for example, its name is changed), we must close and open again this window in order to refresh the information.



The button **Save Dante IP & Name** allows to save in the database the IP addresses of the Dante modules that have been configured so you don't need to write it every time you enter this window. If you close the window and open it again, the connection to the Dante modules is established automatically. Additionally, if the “Console Name” field located on the right is filled out, it allows to define and save the device name at local level.

If the device has been given a name, at the right of the “Dante IP” field appears the name defined in this application (adding “-2” for the second module) and in the “Dante Name” field appears the modules name defined in “Dante Controller” (if they don't match, the second ones appear in red):

**Dante IP**

169 . 254 . 109 . 141 FORUM-ST1

169 . 254 . 109 . 142 FORUM-ST1-2

**Dante Name**

FORUM-17377-1

FORUM-17377-2

In the central part of the window, the **"Name"**, **"Lines"** and **"Clock"** tic-boxes allow you to select which changes you want to make to the Dante module: its name, the name of the Dante channels and/or the clock configuration. Once one or more of these tic-boxes is selected, the "Send" button is enabled, allowing the configuration to be sent to the Dante module.

Name  Lines  Clock

When you check the **"Name"** box and then press the **"Send"** button, the name of the Dante module (the one that appears in the "Dante Controller" application) is changed to the device name defined in "Forum IP Setup":

Name  Lines  Clock

Once the change is made, the name is refreshed and no longer appears in red in the "Dante Name" field:

**Dante Name**

FORUM-ST1

If you want to change the name of both modules at once, you must check the "Name" box of both modules and then press the new **"Send All"** button above:

Name  Lines  Clock

Name  Lines  Clock

Name  Lines  Clock

When you check the **"Lines"** box and then press the **"Send"** button, the names of the transmission and reception channels of the Dante module (the ones that appear in the "Dante Controller" application) are changed to the names of the associated lines defined in "Forum IP Setup":

Name  Lines  Clock

Likewise, you can also change the names of the channels of both modules by using the **"Send All"** button.

The **"Reset Dante lines names"** tic-box allows you to rename the transmission and reception channels of the Dante module with the default names, as they leave the Factory, that is:

FORUM\_1L, FORUM\_1R, FORUM\_2L, etc.

In order to do that, just check that box (automatically, the "Lines" box is also checked) and press the "Send" button:

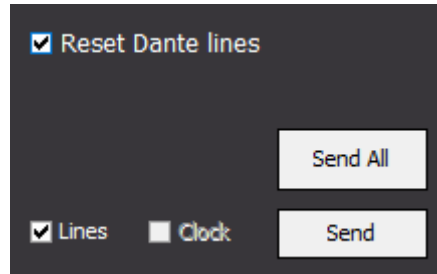

Likewise, you can also reset the names of the channels of both modules by using the **"Send All"** button.

In the upper right part of the window, the **"External Sync"** informative section appears, which shows the way that the device's synchronization is configured at local level:



If you want to change that configuration, you must do it from the "Forum IP Setup" application (see section 4.2.1.2 of this manual).

Below this section, the information about the way that clock should be configured at Dante level appears (and, at the right, the available Dante channels of the module):

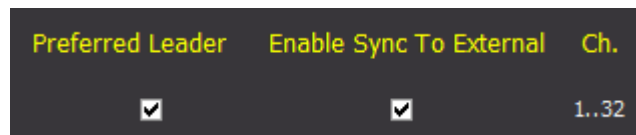

Depending the way the synchronization is configured at local level, the clock should be configured at Dante level, and vice versa (see section 4.7.4.3 of the AEQ AoIP user's manual). If configuration is correct, the information will appear as in the image above; if not, in the **"Preferred Leader"** and/or **"Enable Sync To External"** boxes the "Change" indication will appear in red and it will indicate the way that the associated box in "Dante Controller" should be (checked or not):

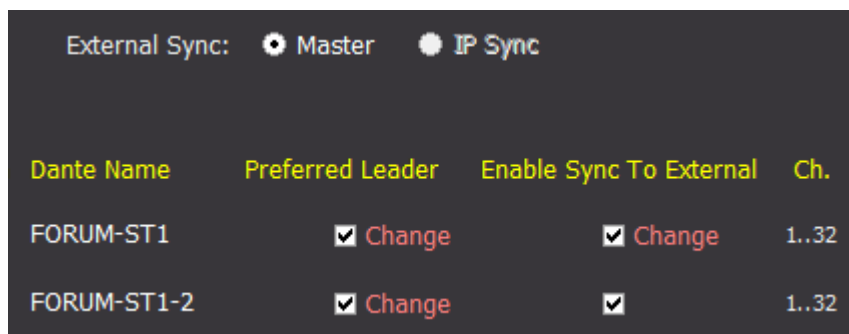

In this example, the unit is configured as "Master" at local level and therefore the "Preferred Leader" and "Enable Sync To External" boxes of both modules should be checked in "Dante Controller", but they are not checked in the first module and the first box is not checked in the second module (so the "Change" indication appears). In order to change it, you can do it from the "Dante Controller" application or, if you prefer, from this window, by checking the "Clock" box and then pressing the "Send" button of each module, or by checking both boxes and pressing "Send All":

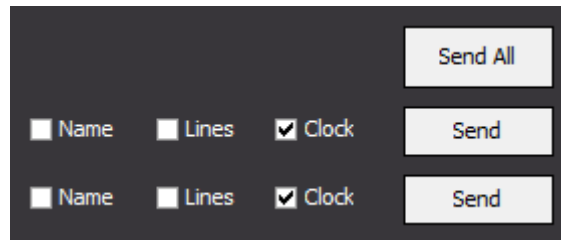

The "Change" indications then disappear to indicate that configuration is now correct:

Dante Name	Preferred Leader	Enable Sync To External	Ch.
FORUM-ST1	<input checked="" type="checkbox"/>	<input checked="" type="checkbox"/>	1..32
FORUM-ST1-2	<input checked="" type="checkbox"/>	<input checked="" type="checkbox"/>	1..32

The "**Dante Domain Manager**" button enables connection to a DDM server. To view enrolled devices, the user must connect to the DDM server using their configured DDM credentials, and then select the appropriate domain for viewing.



When you press it, the following window appears. By pressing the "Edit Config" button, it is possible to edit the fields that appear below:

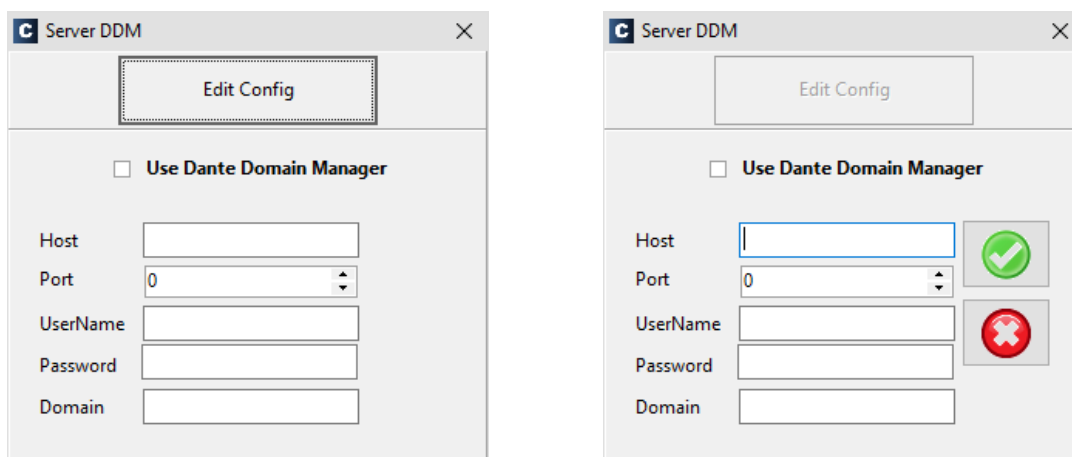

The "Host" and "Port" fields allow to configure IP address and port of DDM server. The "UserName" and "Password" fields allow to configure user and password to access the server. The "Domain" field allows to configure the name of the domain to which the device we want to see is associated.

By checking the "Use Dante Domain Manager" box, the connection to DDM server whose parameters have been configured is activated.

#### 4.1.2. "User Levels" submenu.

"User Levels" submenu is accessed, from the drop-down menu "Administration", by clicking on the icon:



"User Levels" submenu allows you to define the user levels to operate the AEQ FORUM mixing console. Within this submenu there are two distinct areas on the screen:

- The left side shows the list of created user levels.
- The right side shows the list of the permissions that are part of the level selected at that moment in the left part of the screen.



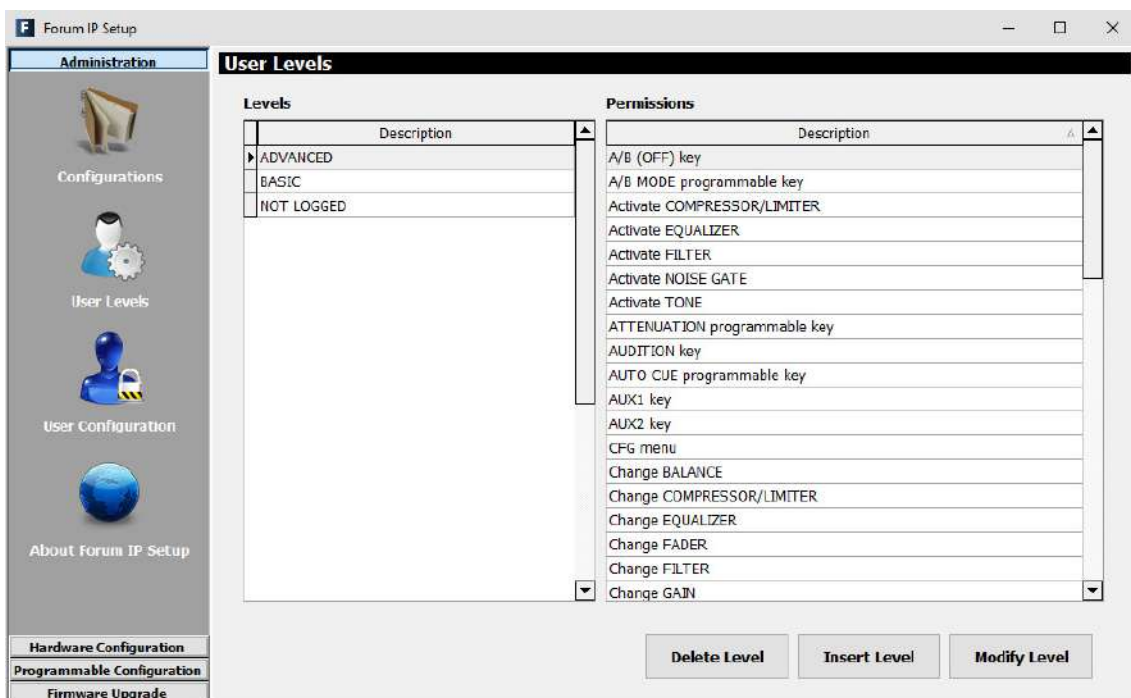

There are 4 user levels defined by default in the AEQ FORUM mixing console: "ADMINISTRATOR", "ADVANCED", "BASIC" and "NOT LOGGED". The "ADMINISTRATOR" level has all the available permissions and does not appear in the list on the left because it cannot be modified or deleted. The "NOT LOGGED" level, which is accessed by pressing the "LOGOU" contextual key in the console's initial menu, can be modified but not deleted. Up to 13 more levels can be defined.

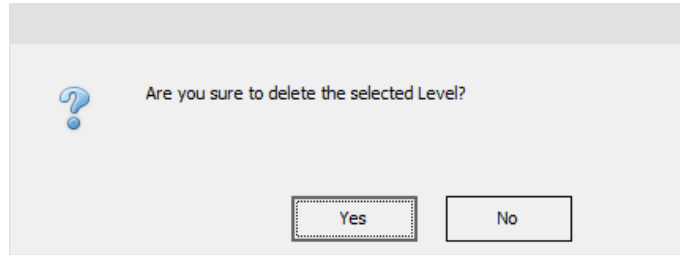

The three buttons at the bottom of the screen allow you to manage the list of user levels and their individual configuration.

- **"Delete Level"**: deletes the selected user level. Confirmation is requested. As previously indicated, the "NOT LOGGED" level cannot be deleted. When a level is associated with a certain user, it cannot be deleted until that user is deleted or a different level is associated with it.



- **"Insert Level"**: allows you to create a new user level and select the permissions to be included through the following menu options:
  - **"Level"**: name for the user level.
  -  adds ALL permissions from the "Available permissions" column to the "Level permissions" column.
  -  adds ONLY the permission selected from the "Available permissions" column to the "Level permissions" column.
  -  removes ONLY the permission selected from the "Level permissions" column back to the "Available permissions" column.
  -  removes ALL the permissions from the "Level permissions" column back to the "Available permissions" column.
  - **"OK"**: allows you to accept the created or edited configuration.
  - **"Cancel"**: allows you to reject the created or edited configuration. No change you may have made is saved.

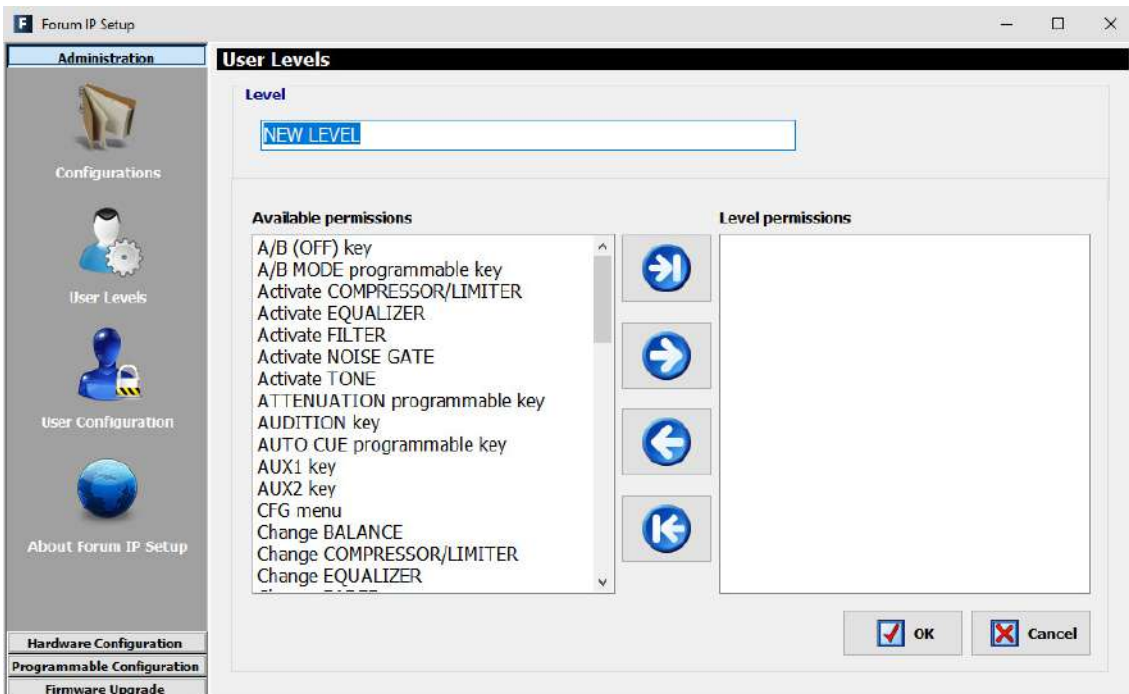

- **"Modify Level"**: allows you to modify the selected and previously created user level. The menu is identical to previously described for "Insert Level" option.

The available permissions are the following ones:

- "A/B (OFF) key": allows to activate the channel OFF key when it works in A/B mode.
- "A/B MODE programmable key": allows to activate/deactivate the "A/B Mode" type programmable key.
- "Activate COMPRESSOR/LIMITER": allows to activate/deactivate the compressor/limiter.
- "Activate EQUALIZER": allows to activate/deactivate the equalizer.
- "Activate FILTER": allows to activate/deactivate the filter.
- "Activate NOISE GATE": allows to activate/deactivate the noise gate.
- "Activate TONE": allows to activate/deactivate the test tone.
- "ATTENUATION programmable key": allows to activate/deactivate the "Studio Monitor Attenuation" type programmable keys.
- "AUDITION key": allows to activate/deactivate the "AUDITION" direct routing key.
- "AUTO CUE programmable key": allows to activate/deactivate the "Auto Cue" type programmable key.
- "AUX1 key": allows to activate/deactivate the "AUX1" direct routing key.
- "AUX2 key": allows to activate/deactivate the "AUX2" direct routing key.
- "CFG menu": allows to access the "CFG" menu and activate/deactivate the available options of that menu.
- "Change BALANCE": allows to modify the signal balance.
- "Change COMPRESSOR/LIMITER": allows to change the configuration parameters of the compressor/limiter.
- "Change EQUALIZER": allows to change the configuration parameters of the equalizer.
- "Change FADER": allows fader position changes to vary the signal level.
- "Change FILTER": allows to change the configuration parameters of the filter.
- "Change GAIN": allows to modify the signal gain.
- "Change IP ADDRESS": allows to access the "IPSET" option of "SETUP" menu and modify the console IP address.
- "Change NOISE GATE": allows to change the configuration parameters of the noise gate.
- "Change PHASE": allows to modify the signal phase.
- "Change ROUTING": allows to modify the signal routing.
- "Change SEL signal in CONTROL": allows to change the signal associated to "SEL" key of control monitoring.
- "Change SEL signal in STUDIO": allows to change the signal associated to "SEL" key of studio monitoring.
- "Change SIGNAL": allows to change the signal assigned to a certain channel.
- "CLOCK menu": allows to access the "CLOCK" menu and activate/deactivate the available options of that menu.
- "CODEC programmable key": allows to activate/deactivate the "Codec" type programmable keys.
- "CONTROL headphones level": allows to modify the level of the control monitoring headphones.
- "CONTROL monitor level": allows to modify the level of the control monitoring speakers.
- "CONTROL MONITORING keys": allows to activate/deactivate the selection keys of the control monitoring.
- "CUE key, CUE level & CUE RESET": allows to activate/deactivate the "CUE" channel keys, modify the level of the CUE speakers and press the "CUE RESET" key.
- "CUE RESET programmable key": allows to activate/deactivate the "Cue Reset" type programmable key.
- "GENERAL programmable key": allows to activate/deactivate the "General" type programmable keys.
- "GPO (OFF) key": allows to activate the channel OFF key when it works in GPO mode.
- "INPUTS menu": allows to access the console inputs menu.
- "Load SNAPSHOTS": allows to load the selected configuration memory or snapshot.
- "MAIN MENU": allows to access the console advanced configuration menu.

- "MEMORY menu": allows to access the "MEMORY" menu with the system configuration memories or snapshots.
- "MEMORY programmable key": allows to activate/deactivate the "Memory" type programmable keys.
- "MULTIPLEX programmable key": allows to activate/deactivate the "Multiplex" type programmable keys.
- "OFF key": allows to activate the channel deactivation key.
- "ON key": allows to activate the channel activation key.
- "ORDERS (OFF) key": allows to activate the channel OFF key when it works in ORDERS mode.
- "ORDERS programmable key": allows to activate/deactivate the "Orders" type programmable keys.
- "OUTPUTS menu": allows to access the console outputs menu.
- "PROGRAM key": allows to activate/deactivate the "PROGRAM" direct routing key.
- "REMOTE PRODUCTION programmable key": allows to activate/deactivate the "Remote Production" type programmable keys.
- "SALVO programmable key": allows to activate/deactivate the "Salvo" type programmable keys.
- "Save SNAPSHOTS": allows to store in the selected configuration memory or snapshot the configuration of the console at that moment.
- "SELECT key": allows to activate/deactivate the "SELECT" channel key.
- "SPLIT CUE programmable key": allows to activate/deactivate the "Split CUE" type programmable keys.
- "STUDIO headphones level": allows to modify the level of the studio monitoring headphones.
- "STUDIO monitor level": allows to modify the level of the studio monitoring speakers.
- "STUDIO MONITORING keys": allows to activate/deactivate the selection keys of the studio monitoring.
- "TALKBACK keys": allows to activate/deactivate the Talkback section keys.
- "TALKBACK level": allows to modify the Talkback microphone gain.
- "TO MIXER BUS programmable key": allows to activate/deactivate the "To Mixer Bus" type programmable keys.

In some cases, it's necessary to assign several permissions to a certain level in order to perform certain options.

For example, if we assign the "Load SNAPSHOTS" (or "Save SNAPSHOTS") permission to a user level, we must also assign the "MEMORY menu" permission to be able to access the menu where any of these two options are executed.

Another example is given if we assign the "Activate TONE" permission to a user level: in this case, we must also assign the "MAIN MENU" and "OUTPUTS menu" permissions to be able to access the menu where that test tone can be activated/deactivated.

Another example is given if we assign the "A/B (OFF) key", "GPO (OFF) key" or "ORDERS (OFF) key" permission to a user level: in this case, we must also assign the "OFF key" permission to be able to activate any of the previous options.

### 4.1.3. "User Configuration" submenu.

"User Configuration" submenu is accessed, from the drop-down menu "Administration", by clicking on the icon:



"User Configuration" submenu allows you to define the users (and associate them a certain level) with access to operate the AEQ FORUM mixing console.

The display in this submenu shows the list of registered users and their associated parameters:

- **"User"**: alphanumeric name of the user. The maximum number of digits is limited to 32. In the upper right part of the main display the name of the active user at that moment is shown.
- **"Password"**: password associated with the user: number combination of up to 32 digits from zero to nine, although a **maximum of 6 digits** is recommended (a password with more than 6 digits could be used just to access the software, but couldn't be used in the console). This password is used to access all the permitted actions in advanced menu, from the main screen of the Control and Monitoring section of AEQ FORUM. For more information see section 3.2 of this manual.
- **"Access Level"**: user level associated with the name and password previously configured (you can check the password associated with a user by means of edition button). AEQ FORUM allows up to 17 different user levels.

There are 4 user levels defined by default in the console: "ADMINISTRATOR", "ADVANCED", "BASIC" and "NOT LOGGED". The "ADMINISTRATOR" level has all the available permissions. The "NOT LOGGED" level cannot be selected in the "Access Level" column: it corresponds to a generic user with no associated password, which is accessed by pressing the "LOGOU" contextual key in the console's initial menu.

The permissions associated with each user level can be checked in the "User Levels" submenu of the application. Section 4.1.2 of this manual details this submenu, as well as the process for creating and modifying the system user levels.

- **"ID"**: internal reference number for each user automatically and sequentially assigned.

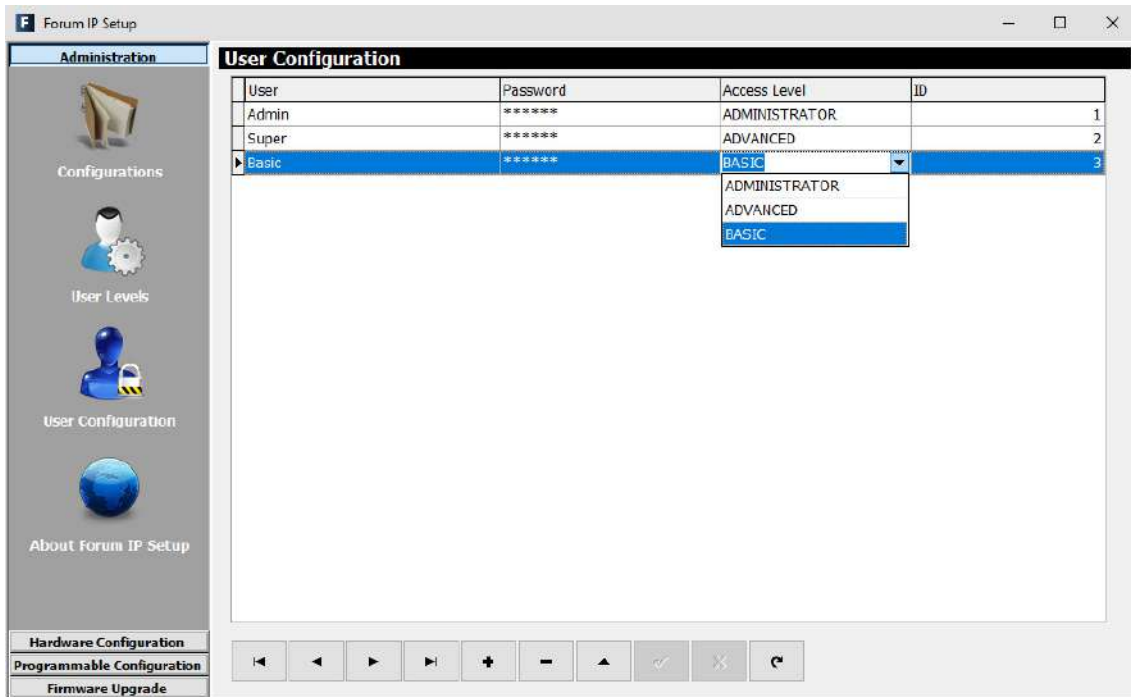



The lower part of the "User Configuration submenu includes a set of standardized buttons to manage the list of registered users:

- 

Allows you to scroll to the top of the list.
- 

Allows you to move to the position immediately above in the list.
- 

Allows you to move to the position immediately below in the list.
- 

Allows you to scroll to the last position of the list.
- 

Allows you to insert a new entry in the list.
- 

Allows you to delete the selected entry from the list. Confirmation is requested.
- 

Allows you to edit the selected entry and check the password associated with that user.
- 

Allows you to accept changes to the selected entry.
- 

Allows you to reject changes to the selected entry.
- 

Allows you to refresh the information shown in the list.

#### 4.1.4. "About Forum IP Setup" submenu.

"About Forum IP Setup" submenu is accessed, from the drop-down menu "Administration", by clicking on the icon:



"About Forum IP Setup" submenu simply shows information regarding the software version and the current user logged into the application.



#### 4.2. "Hardware Configuration" menu.

This menu allows you to configure the system inputs and outputs modules as well as the logical audio channels created from the physical inputs and outputs. Clicking on the "Hardware Configuration" section on the left side of the screen displays the full list of submenus, which includes:

- **"Board Configuration"**: allows you to define the settings of faders, audio inputs/outputs modules and GPIOs of the Mixing Console, as well as define the digital nominal level and configure MAD1 and AoIP functionalities.
- **"Mixer Bus Configuration"**: allows you to define the configuration of the internal summing buses of the mixing console.
- **"I/O Configuration"**: enables the configuration of logical audio channels based on the physical audio inputs and outputs as defined in the "Board Configuration" submenu.
- **"Monitoring Configuration"**: allows you to define the operation of the Control and Monitoring sections that are associated with the control and studio rooms.
- **"Visual Radio"**: allows you to configure the "Visual Radio" functionality.
- **"NTP Client"**: allows you to configure and activate time and date synchronization with a remote NTP server. Once configured this server will work as the master clock for the local time of the AEQ FORUM.
- **"Vumeters"**: allows you to configure the vumeters transmission mode.

- **"Options"**: allows you to configure the operation mode of the sends to the summing buses and of the channel activation keys.

In order to access to any of these submenus, it's necessary to have a configuration loaded in the application: in case there's no configuration, the message **"Empty configuration. Please read configuration before use"** would be displayed and you should have to either connect to AEQ FORUM console and read its configuration or load a configuration by means of "Import" option (see section 4.1.1 of this manual; you can find the "DemoConfiguration.FSC" file in C:\Program files\ForumIpSetup\Demos).

#### 4.2.1. "Board Configuration" submenu.

"Board Configuration" submenu is accessed, from the drop-down menu "Hardware Configuration", by clicking on the icon:



"Board Configuration" submenu enables the definition of fader settings, audio inputs/outputs modules and GPIOs of the mixing console, as well as define the digital nominal level and configure MADi and AoIP functionalities.

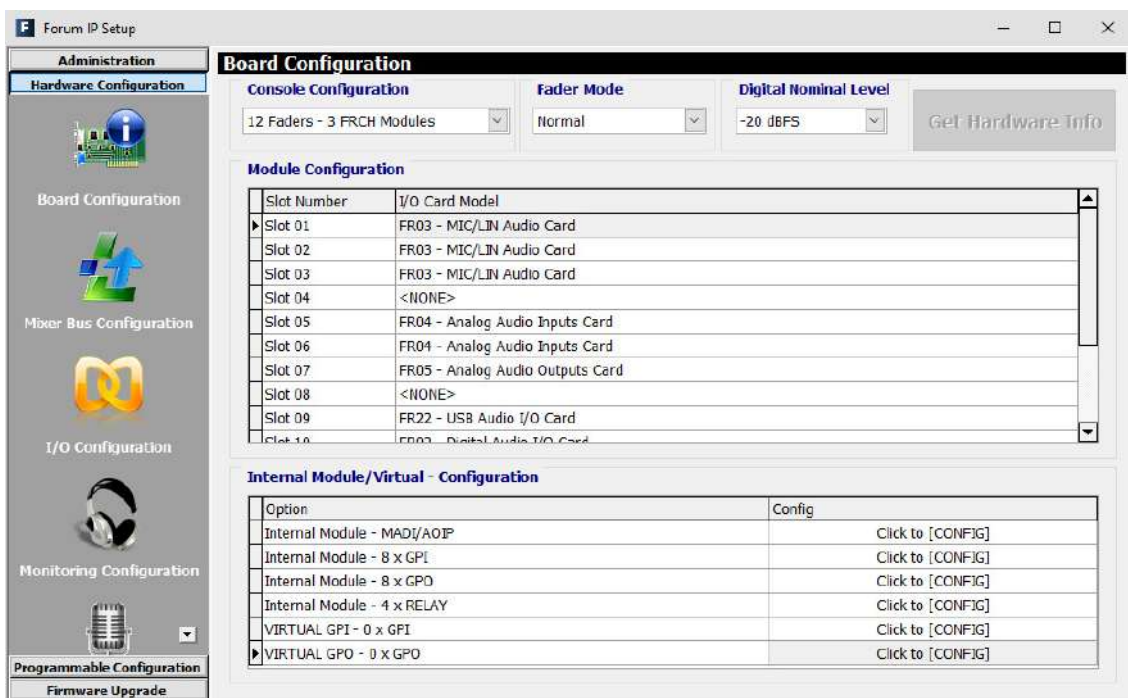

From left to right and from top to bottom the available options are:

- **"Console Configuration"**: here you can set the number of 4 faders modules (FRCH) that are installed in **AEQ FORUM / GRAND FORUM / FORUM SPLIT**:
  - **1 FRCH module** corresponds to **4 faders** in the control surface. The remaining space should be filled with 2 FR20 blank modules.
  - **2 FRCH modules** correspond to **8 faders**. The remaining space should be filled with a FR20 blank module.
  - **3 FRCH modules** correspond to **12 faders**.
  - **4 FRCH modules** correspond to **16 faders**. The remaining space should be filled with a FR20 blank module (only for **GRAND FORUM** and **SPLIT**).

- **5 FRCH modules** correspond to **20 faders** (only for **GRAND FORUM** and **SPLIT**).
- **6 FRCH modules** correspond to **24 faders** (only for **FORUM SPLIT**).
- **"Fader Mode"**: allows you to configure the position of the nominal operating setting (**+0dB**) of the console faders. When "Normal" option is selected that gain is placed at the third band from above, while when "Full Throw" is selected that gain is placed at the upper position of fader.

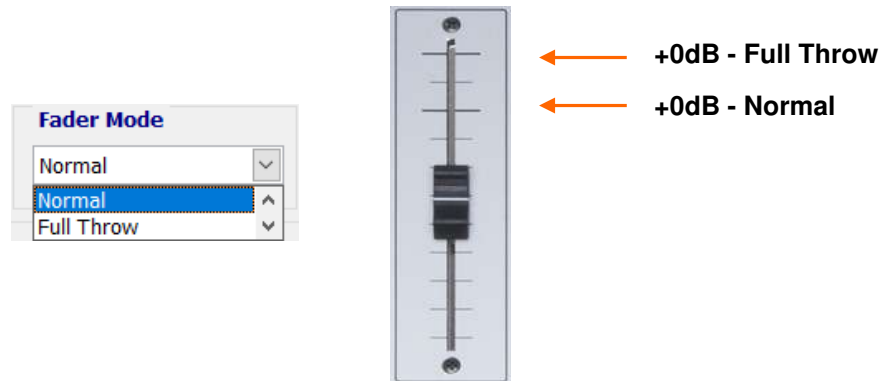

- **"Digital Nominal Level"**: allows you to configure the digital nominal level of the console. By default, the nominal level of AEQ consoles for digital signals is **-20dBFS**. There is an adjustment margin of  $\pm 12\text{dB}$  by means of gains configuration.

By means of the drop-down menu it's possible to modify the digital nominal level to **-14dBFS** or **-18dBFS**. There is also an adjustment margin of  $\pm 12\text{dB}$ .

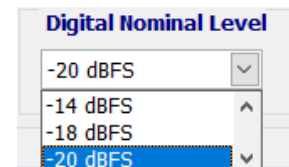

- **"Get Hardware Info"**: allows you to load automatically in the application the configuration of hardware modules integrated into the console. By clicking on this option, the ForumSetup software communicates with the AEQ FORUM mixing console (therefore, there should be connection between the computer where is running the configuration software and one of the network ports of the mixing console) and retrieves the hardware configuration as installed in your system.

**IMPORTANT NOTE:** when there is a configuration loaded yet in the application, this option overwrites that configuration, changing the name of logical lines, routing... That's why you will be asked for a confirmation:

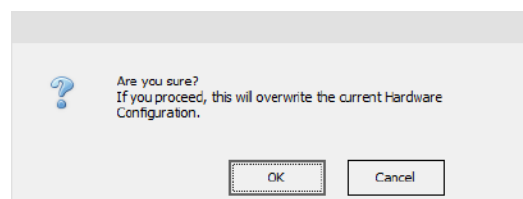

Therefore, we recommend you to previously save the loaded configuration by means of **"Export"** option (see section 4.1.1) and, when a new configuration is being prepared, to use this hardware synchronization option as first step of the process, before configuring any other parameter.

- **"Module Configuration"**: it shows the audio inputs and outputs modules of the 14 different slots available on the rear panel of AEQ FORUM. This option also allows you to configure manually (as opposed to the automatic option "Get Hardware Info") the type of module placed in each slot.
- **"Internal Module/Virtual - Configuration"**: allows you to configure the general purpose inputs and outputs GPIO (both the physical contact relays, the opto-coupled and the virtual GPIOs) that are available on the rear panel in the section of common inputs and outputs of the AEQ FORUM. It also allows you to configure the operation of the optional

multi-channel AES10 MADI communications module (available by means of user license: see section 4.1.1 of this manual) and the AoIP functionality.

#### 4.2.1.1. "Module Configuration" section.

"Module Configuration" section of "Board Configuration" submenu shows you a list of the audio inputs and outputs modules of the 14 different slots available on the rear panel of AEQ FORUM. This option also lets you configure manually (as opposed to the automatic option "Get Hardware Info") the type of module placed in each slot.

The fields in this list are:

- **"Slot number"**: identifies the physical position of this module on the 14 slots rear panel of AEQ FORUM.
- **"I/O Card Model"**: type of configured audio inputs/outputs module. Each one of these 14 positions corresponds to the 14 physical slots at the rear panel of the console and can be configured as follows:
  - **<NONE>**: no module inserted or detected.
  - **FR02 - Digital Audio I/O Card.**
  - **FR03 - MIC/LIN Audio Card.** Used for both FR03 and FR03S modules.  
**IMPORTANT NOTE:** only slots 1 to 4 can be used for this type of module. When you try to configure it in another slot an error message appears:

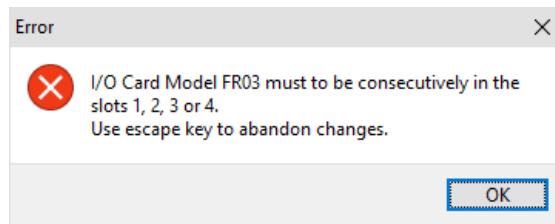

- **FR04 - Analog Audio Inputs Card.**
- **FR05 - Analog Audio Outputs Card.**
- **FR14 - AOIP Audio I/O Card.**  
**IMPORTANT NOTE:** AEQ FORUM supports up to two FR14 modules per console and these can be installed only in slots 13 and 14 (when there is only one module, it will be placed in slot 14). When you try to configure it in another slot an error message appears.
- **FR22 - USB Audio I/O Card.**
- **FR33 - Hybrid Audio Card.**  
**IMPORTANT NOTE:** AEQ FORUM supports up to two FR33 modules per console; when you try to configure more than 2 modules, an error message appears:

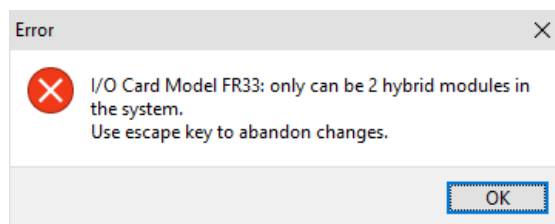

For more information about each of these audio inputs and outputs modules, please refer to section "2.2.3. Audio inputs/outputs modules" of this manual.

#### 4.2.1.2. "Internal Module/Virtual - Configuration" section.

"Internal Module/Virtual - Configuration" section of "Board Configuration" submenu allows you to configure the general purpose inputs and outputs **GPIO** (both the physical contact relays and the opto-coupled) that are available on the rear panel in the section of common inputs and outputs of the AEQ FORUM (please refer to section 2.2.2.1 of this manual), as well as the virtual GPIOs. It also allows to configure the operation of the optional multi-channel **AES10 MADI** communications module (please refer to section 2.2.2.7 of this manual; this module is available only by means of user license) and the **AoIP** functionality.

**IMPORTANT NOTE: MADI and AoIP** (audio over IP) functionalities are not compatible, both options can't be active at the same time.

There are six distinct areas in this section:

1. **MADI/AOIP:** allows you to configure MADI and AoIP functionalities. The advanced configuration menu of this optional module is accessed by clicking "**Click to [CONFIG]**" and then clicking again on the "**Config**" button that will appear. A window with 2 tabs will appear (in order to change from one tab to the other the selected option must be "**Disabled**").
  - **MADI:** is an optional communication module within the system common I/O section (available by means of user license: see section 4.1.1 of this manual). This is a bi-directional fiber-optic multi-channel audio link. The physical interface is a transceiver and the implemented standard is AES10-2003. The configuration options are:
    - "**Disabled / Enabled**": deactivates or activates the module.
    - "**Sync**": allows you to configure whether the console will use the synchronism extracted from MADI link ("Slave") or not ("Master").
    - "**Used**": allows you to configure how many of the 64 mono channels available are actually in use.

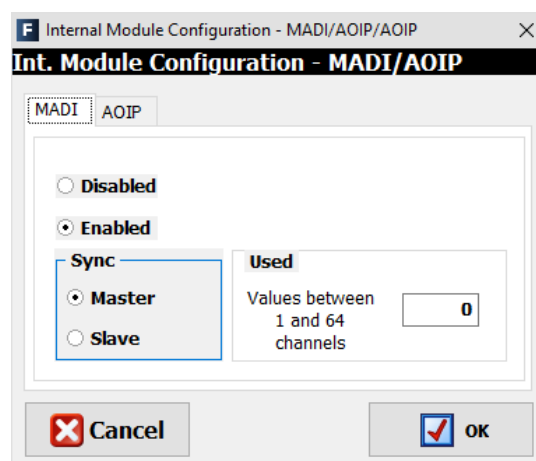

- **AOIP:** FR14 AoIP modules are installed as any other input/output module on the rear panel of the console and give you up to 32 input audio channels and up to 32 output audio channels per module. The maximum number of FR14 modules present in any AEQ FORUM console is 2. The configuration options are:
  - "**Disabled / 32 Channels / 64 Channels**": allows you to deactivate this option or select between 32 or 64 channels (depending on how many FR14 modules will be installed: one or two).
  - "**Sync**": allows you to configure whether the console will use the synchronism extracted from AoIP link ("Slave"; when there are 2 FR14 modules, the one placed in slot 14 prevails over the one in slot 13) or not ("Master").

- **"Used"**: allows you to configure how many of the 32 or 64 mono channels available are actually in use.

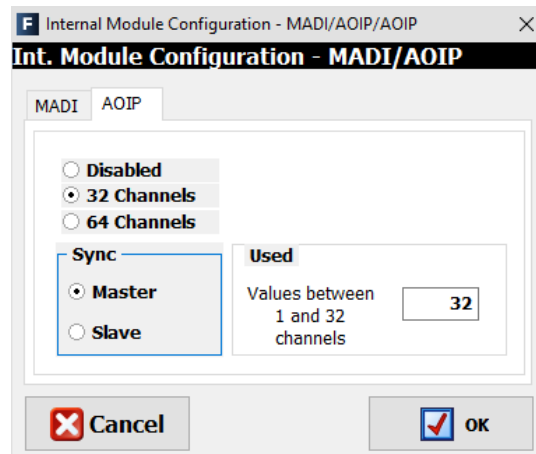

2. **GPI**: General Purpose Inputs. AEQ FORUM incorporates 8 opto-coupled GPIs on open-collector transistors.

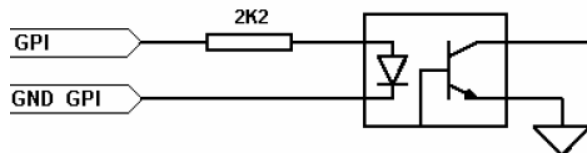

The advanced configuration menu of GPIs is accessed by clicking **"Click to [CONFIG]"** and then clicking again on the **"Config"** button that will appear. The configuration options are:

- Edit the "Label" to identify the assigned role.
- Configure the working mode ("Level" column) of each GPI. The options are:
  - "High": GPI activated on high level.
  - "Low": GPI activated on low level.
  - "On Change": GPI activated by transitions from high to low or the inverse.
  - "TH02": GPI to accept the particular signalling that is generated by the AEQ TH-02EX MkII digital hybrid, as well as to enable the remote control of this particular equipment.

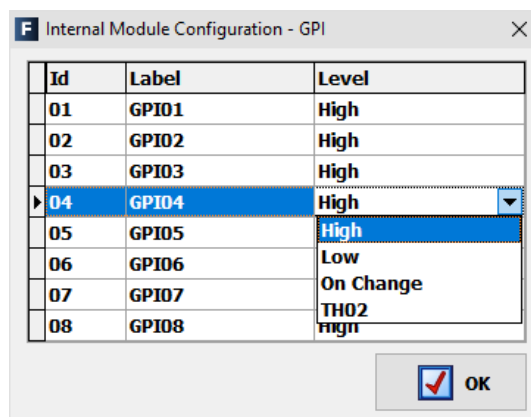

3. **GPO**: General Purpose Outputs. AEQ FORUM incorporates 8 opto-coupled GPOs on open collector transistors.

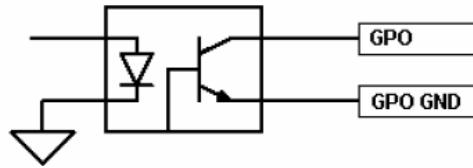

The advanced configuration menu of GPOs is accessed by clicking "**Click to [CONFIG]**" and then clicking again on the "**Config**" button that will appear. The configuration options are:

- Edit the "Label" to identify the assigned role.
- Configure the working mode ("Level" column) of each GPO. The options are:
  - "Level High": GPO activated on high level.
  - "Level Low": GPO activated on low level.
  - "On Change": GPO is activated by transitions from high to low or the inverse.
  - "Pulse High": output in the form of a high level pulse with a duration that is defined in milliseconds in the field "Duration".
  - "Pulse Low": output in the form of a low level pulse with a duration that is defined in milliseconds in the field "Duration".

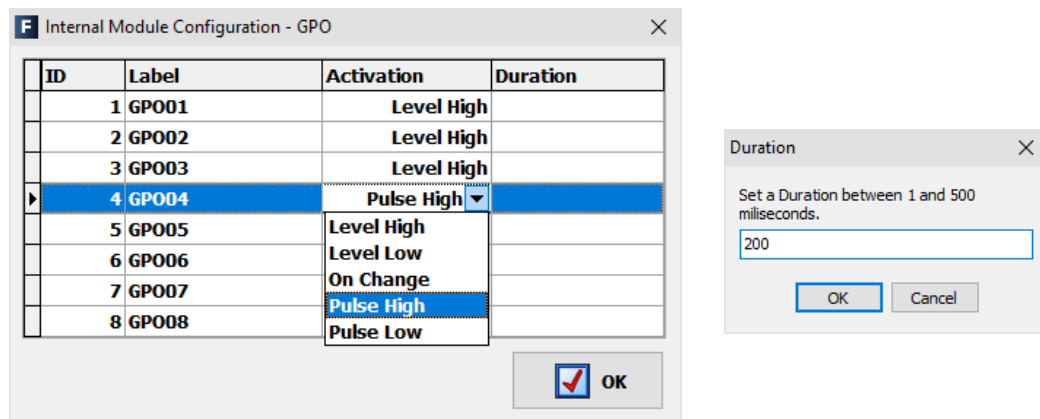

ID	Label	Activation	Duration
1	GP001	Level High	
2	GP002	Level High	
3	GP003	Level High	
4	GP004	Pulse High	
5	GP005	Level High	
6	GP006	Level Low	
7	GP007	On Change	
8	GP008	Pulse High	
		Pulse Low	

4. **RELAY:** allows you to configure the GPO outputs on physical contact relays as opposed to the opto-coupled GPOs on open collector transistors. There are four contact relays or contacts.

The advanced configuration menu of GPOs is accessed by clicking "**Click to [CONFIG]**" and then clicking again on the "**Config**" button that will appear. This configuration menu is exactly like the previously detailed for GPOs.

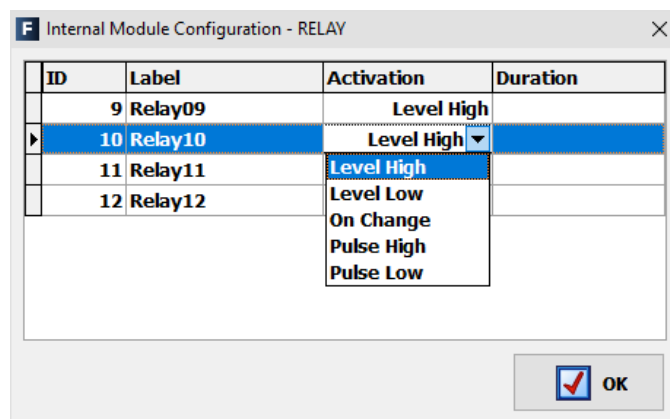

ID	Label	Activation	Duration
9	Relay09	Level High	
10	Relay10	Level High	
11	Relay11	Level High	
12	Relay12	Level Low	
		On Change	
		Pulse High	
		Pulse Low	

5. **VIRTUAL GPI:** allows you to configure the Virtual GPIs, General Purpose Inputs that come into the unit through an IP connection. Up to **246** virtual GPIs can be configured.

The advanced configuration menu of Virtual GPIs is accessed by clicking "**Click to [CONFIG]**" and then clicking again on the "**Config**" button that will appear.

The window that appears allows you to create and edit virtual GPIs.

The available options of this configuration window are:

- **IP:** **optional** field that allows you to edit the IP address in order to define the origin of the received orders.
- **Id Number:** allows you to assign an order number to virtual GPI into the unit, that must be less than 256. Id Number can not be duplicate.
- **Label:** allows you to assign a label to virtual GPI in order to identify it into the unit. When no label is assigned, it's identified as "Virtual GPI *Id Number* - *IP*".

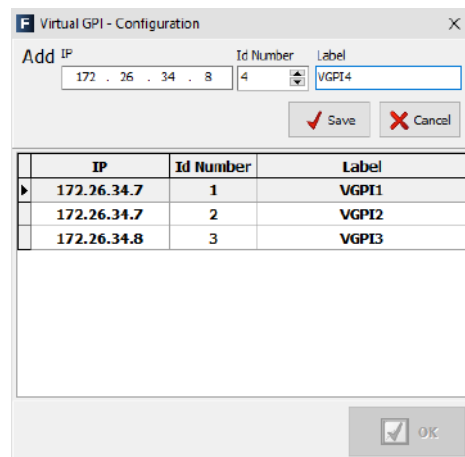
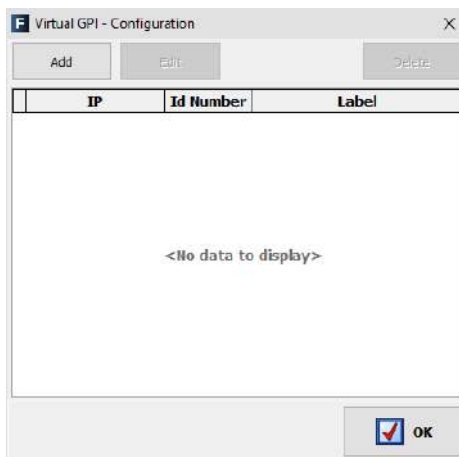

6. **VIRTUAL GPO:** allows you to configure the Virtual GPOs, General Purpose Outputs that are sent to other units through an IP connection. Up to **242** virtual GPOs can be configured.

The advanced configuration menu of Virtual GPIs is accessed by clicking "**Click to [CONFIG]**" and then clicking again on the "**Config**" button that will appear.

The window that appears allows you to create and edit virtual GPOs.

The available options of this configuration window are:

- **IP:** **mandatory** field that allows you to edit the IP address in order to define the destination of the generated orders.
- **Id Number:** allows you to assign an order number to virtual GPO into the unit, that must be less than 256. The same virtual GPO can be sent to different units, in that case the same Id Number must be assigned to different IP addresses.
- **Label:** allows you to assign a label to virtual GPO in order to identify it into the unit. When no label is assigned, it's identified as "Virtual GPO *Id Number* - *IP*".

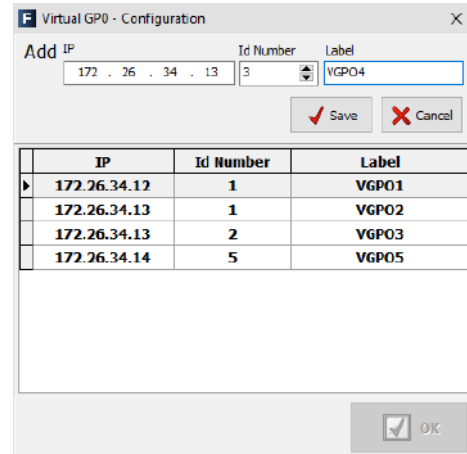
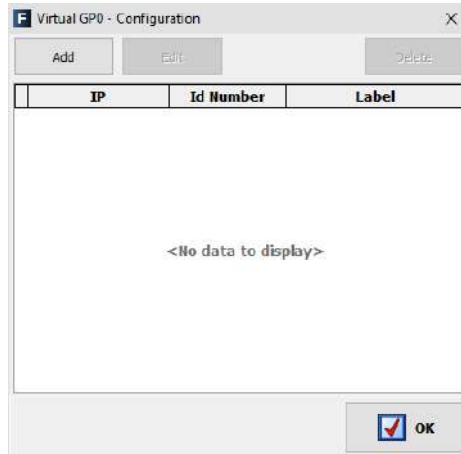

**IMPORTANT NOTE:** The "ETHERNET" port is the one of the two Ethernet connectors that must be necessarily used if you want to use **virtual GPIs** or **GPOs**.

#### 4.2.2. "Mixer Bus Configuration" submenu.

"Mixer Bus Configuration" submenu is accessed, from the drop-down menu "Hardware Configuration", by clicking on the icon:



"Mixer Bus Configuration" submenu allows you to define the configuration of the internal summing buses of the mixer. AEQ FORUM is supplied configured with the following factory default buses:

- **"Program"**: stereo and with working mode defined as "Program".
- **"Audition"**: stereo and with working mode defined as "Audition".
- **"Aux 1"**: stereo and with working mode defined as "Aux 1".
- **"Aux 2"**: stereo and with working mode defined as "Aux 2".
- **"Cue"**: PFL bus, stereo and with working mode defined as "Cue".
- **"Studio"**: output bus toward studio monitors and headphones, stereo and with working mode defined as "Studio".
- **"Control"**: output bus toward control monitors and headphones, stereo and with working mode defined as "Control".
- **"MPX 1"**: mono and with working mode defined as "MPX 1".
- **"MPX 2"**: mono and with working mode defined as "MPX 2".
- **"MPX 3"**: mono and with working mode defined as "MPX 3".
- **"MPX 4"**: mono and with working mode defined as "MPX 4".
- **"MPX 5"**: mono and with working mode defined as "MPX 5".
- **"MPX 6"**: mono and with working mode defined as "MPX 6".

You can edit the "Label" for each mixer bus. If a mixer bus in factory configured as stereo is reconfigured to mono, the liberated channel will pop up on the configuration screen as available. The opposite would happen if you change the settings for an initially mono bus, "MPX 1" for instance: when you reconfigure it for stereo operation, the next bus line, "MPX 2" in this case, will disappear from the available buses on the configuration screen since this bus will be added to "MPX 1".

You can define up to 32 mono or 16 stereo mixer buses, including the 7 predefined stereo buses and the 6 MPX (N-1) mono buses as described above. The remainder of mixing buses can be defined as "Internal"; 4 of them could be defined as mono buses with "MPX 7", "MPX 8", "MPX 9" or "MPX 10" working mode.

**IMPORTANT NOTE:** For firmware versions 1.73 of CPU and 1.31 of DSP Router or higher, the routing toward MPX internal summing buses is saved on console configuration and it will appear in the "Routing Configuration" submenu when the active configuration is read.

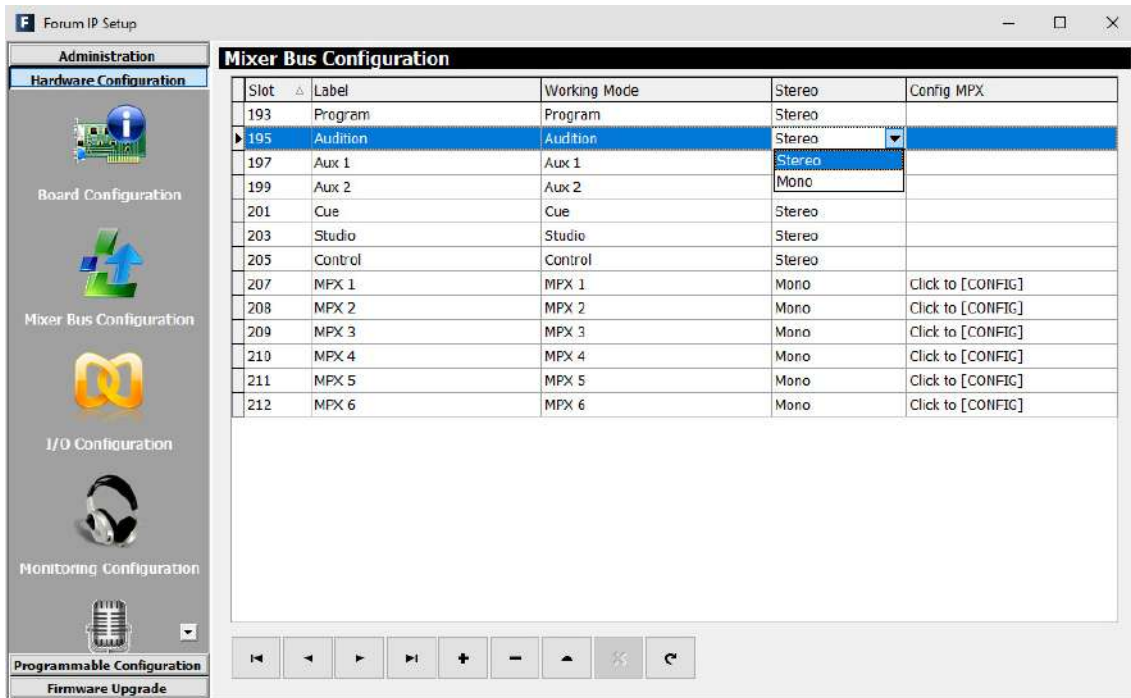

The mixer bus configuration table has the following fields:



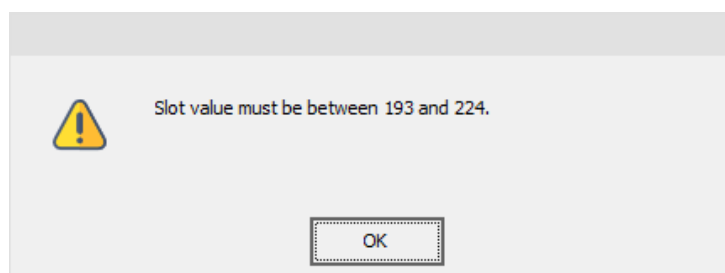





- **"Slot"**: indicates the internal position of this signal in the digital audio bus of the mixer. The 32 available slots are numbered between 193 and 224 both inclusive. A warning message will appear when you try to define a bus above those 32 available slots:



- **"Label"**: name of the bus. Maximum number of characters recommended is 6.
- **"Working Mode"**: is the description provided by the system regarding the functionality of each bus: Program, Audition, Aux 1, Aux 2, Cue, Studio, Control, MPX 1 to 10 or Internal.
- **"Stereo"**: allows you to configure the bus as a mono or stereo one.
- **"Config MPX"**: allows you to configure the working mode of the selected MPX bus as "Multiplex" or "Clean Feed". To access, click on **"Click to [CONFIG]"** and then clicking again on the **"Config"** button that will appear. See sections 4.2.2.1 and 4.3.2.5 of this manual.

By clicking on each column header, the table will be sorted in accordance to this column.

The lower part of the "Mixer Bus Configuration" submenu includes a set of standardized buttons to manage the list of internal buses:

-  Allows you to scroll to the top of the list.
-  Allows you to move to the position immediately above in the list.
-  Allows you to move to the position immediately below in the list.
-  Allows you to scroll to the last position of the list.
-  Allows you to insert a new entry in the list.
-  Allows you to delete the selected entry from the list. Confirmation is requested.
-  Allows you to edit the selected entry.
-  Allows you to reject to the selected entry.
-  Allows you to refresh the information shown in the list.

#### 4.2.2.1. Configuration of MPX buses menu. "Clean Feed" mode.

When you press the "Config" button, that appears after clicking on "Click to [CONFIG]", the following window will appear:

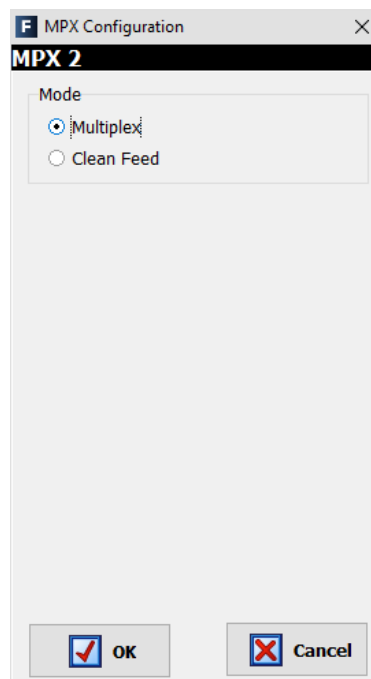

When the selected bus maintains the "Multiplex" option selected (this is the default option), the working mode is the usual for these buses: see section 4.3.2.5 of this manual.

When the "Clean Feed" option is selected, the window will change to:

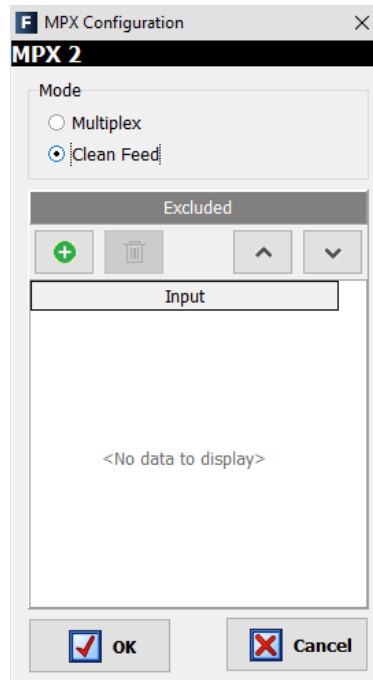

and allows you to configure a special group of multiplex named "Clean Feed", that allows to **automatically** establish a routing of the active signals in a certain moment toward that bus, with no need of explicitly routing.

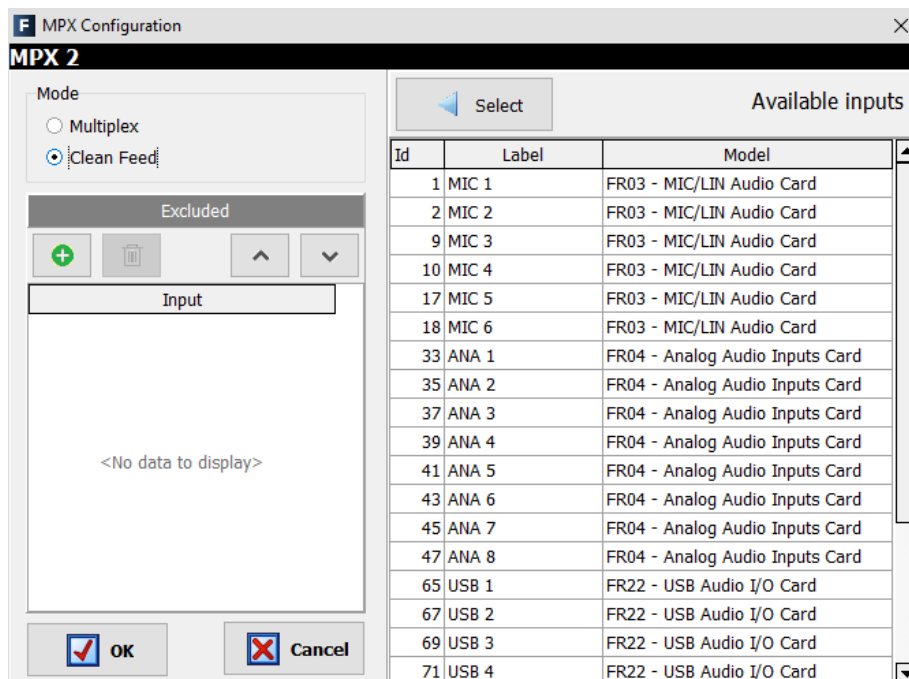

The input signal or signals that will be excluded from that "Clean Feed" group must be added in "Excluded" section. When the button  is pressed a list of all the system available inputs will appear at the right:

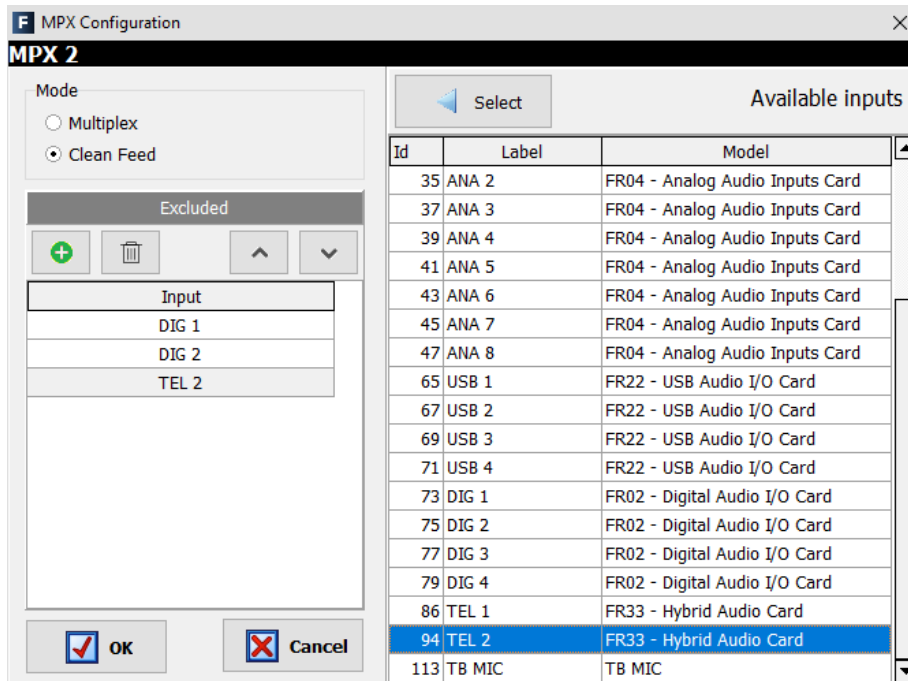

In order to exclude an input from the group just select it in the list and press the "Select" button.



In the example, the "DIG 1", "DIG 2" and "TEL 2" inputs have been excluded from the group associated with "MPX 2" bus. The **order is very important** in this kind of "Clean Feed" groups because the first selected input will establish the operative **priority** in that group in each moment.

You can eliminate an input from the "Excluded" section by means of the button  and you can modify the order of the selected inputs (when there is more than one, obviously) by means of the buttons  and .

When you press "OK" creation of the group is confirmed and the window is closed. If you open it again, by pressing the "CONFIG" button, you can check the excluded signals and edit this selection (add/eliminate inputs or modify the order):

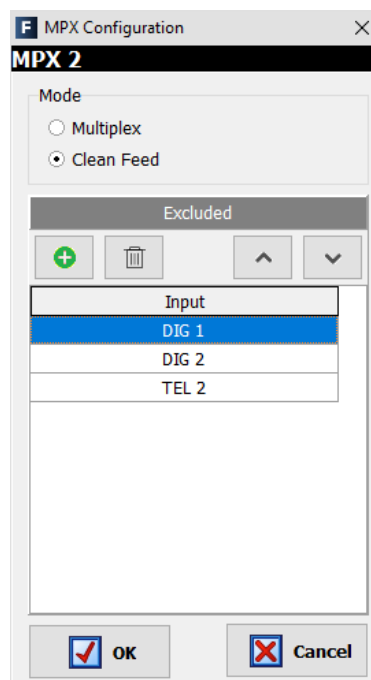

Once the group is defined ("MPX 2" in the example) the operation is as follows:

- Priority 5:** Let's suppose that the starting point is that none of the routing keys ("PROGRAM", "AUDITION", "AUX 1" and "AUX 2") of the inputs in control surface is activated.  
 All the inputs in control surface that are active in a certain moment (by pressing the "ON" key of the channel) will send signal to the "MPX 2" bus, except the ones that appears in "Excluded" section ("DIG 1", "DIG 2" and "TEL 2" in the example).
- Priority 4:** If we activate now in "DIG 1" channel (the one that appears in first place in "Excluded" section) the "AUX 2" routing key (whether the channel is active or not), this will be the new operative priority of the group, so only the active channels ("ON" key pressed) with also the "AUX 2" routing key activated (and NOT the other routing keys) will send now signal to the "MPX 2" bus.
- Priority 3:** If we activate now in "DIG 1" channel the "AUX 1" routing key (whether the channel and the "AUX 2" key are active or not), this will be the new operative priority of the group, so only the active channels ("ON" key pressed) with also the "AUX 1" routing key activated (and NOT the "PROGRAM" and "AUDITION" keys) will send now signal to the "MPX 2" bus.
- Priority 2:** If we activate now in "DIG 1" channel the "AUDITION" routing key (whether the channel and the "AUX 1" and "AUX 2" keys are active or not), this will be the new operative priority of the group, so only the active channels ("ON" key pressed) with also the "AUDITION" routing key activated (and NOT the "PROGRAM" key) will send now signal to the "MPX 2" bus.
- Priority 1:** If we activate now in "DIG 1" channel the "PROGRAM" routing key (whether the channel and the other routing keys are active or not), this will become the new operative priority: only the active channels ("ON" key pressed) with also the "PROGRAM" key activated will send signal to "MPX 2" (these channels may have the other routing keys activated or not, it doesn't matter).

As seen, the routing of "DIG 1" input defines the operative priority and therefore the inputs that will send signal to "MPX 2" group in a certain moment, being the sending to "PROGRAM" the higher priority (1) and all the sending deactivated the lower priority (5).

For instance, when the configuration of channels activation and routing in control surface in a certain moment is as follows:



In this case, the "DIG 1" signal defines an operative **priority 1** because the "PROGRAM" routing key is activated (it doesn't matter that the "AUDITION" key is also activated and the channel is not active). "DIG 1", "DIG 2" and "TEL 2" signals will not be sent to "MPX 2" bus because they are excluded from the group.

This way, "MIC 1", "DIG 5" and "TEL 1" signals will be sent to "MPX 2" because these channels are active and their "PROGRAM" routing keys are activated. However, "MIC 2", "MIC 4" and "DIG 4" will not be sent to "MPX 2" because they are active but the "PROGRAM" routing key is not activated. Finally, "MIC 3", "DIG 3" and "DIG 6" signals will not be sent to "MPX 2" because these channels are not active.

If we deactivate now the "PROGRAM" key of "DIG 1" we change to **priority 2** because the sending to "AUDITION" is still activated. This way, only "MIC 4" signal will be sent now to "MPX 2" because it's the only active channel with the "AUDITION" key activated and the "PROGRAM" key deactivated ("DIG 2" has also the same situation but this channel is excluded from the group).

Finally, if we deactivate now the "AUDITION" key of "DIG 1" we change to **priority 5**. This way, only "MIC 2" signal will be sent to "MPX 2" because it's the only active channel with no routing keys activated.

In next example, in addition to that "MPX 2" group, a second group, "MPX 3", is created excluding the "MIC 1" input from it:

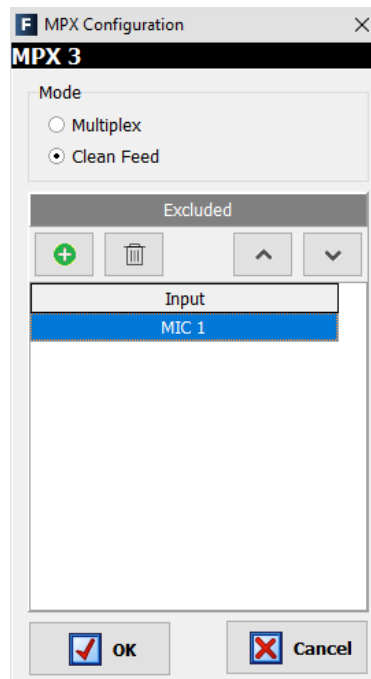

Supposing the configuration of channels activation and routing of the previous image, the "MIC 1" signal defines also in this case an operative **priority 1** for "MPX 3" group because the "PROGRAM" routing key is activated (it doesn't matter that the "AUDITION" and "AUX 2" keys are also activated). This signal will not be sent to "MPX 3" bus because it's excluded from this group.

This way, "DIG 5" and "TEL 1" signals will be sent to "MPX 3" because both channels are active and their "PROGRAM" routing keys are activated. However, "MIC 2", "MIC 4", "DIG 2" and "DIG 4" channels will not be sent to "MPX 3" because they are active but the "PROGRAM" routing key is not activated, and neither "DIG 1" channel because the "PROGRAM" key is activated but the channel is not active. Finally, "MIC 3", "DIG 3", "DIG 6" and "TEL 2" signals will not be sent to "MPX 3" because these channels are not active.

If we deactivate now the "PROGRAM" key of **"MIC 1"** we change to **priority 2** because the sending to **"AUDITION"** is still activated. This way, now "MIC 4" and "DIG 2" signals will be sent now to "MPX 3" because these are the only active channels with the "AUDITION" key activated and the "PROGRAM" key deactivated.

Then, if we deactivate now the "AUDITION" key of **"MIC 1"** we change to **priority 4** because the sending to **"AUX 2"** is still activated. This way, now only "DIG 4" signal will be sent to "MPX 3" because it's the only active channel with just the "AUX 2" key activated.

Finally, if we deactivate now the "AUX 2" key of **"MIC 1"** we change to **priority 5**. This way, only "MIC 2" signal will be sent to "MPX 3" because it's the only active channel with no routing keys activated.

**NOTE:** If you define a "Multiplex" programmable key and you assign to that key an MPX bus configured as "Clean Feed", when you press and keep pressed the key, the "SELECT" key of the channels that are sending signal toward that bus will turn on. As previously mentioned, that sending is **automatic** because "Clean Feed" mode is used, while the routing is usually activated/deactivated manually when "Multiplex" mode is used. Although it's not the usual operation, you can temporarily deactivate the sending of a certain channel toward the MPX bus by keeping pressed the programmable key and pressing the "SELECT" key of the channel; this sending will be automatically recovered when you deactivate and reactivate the channel by means of the "ON" key (o when you deactivate and reactivate the routing key) or manually by pressing again the programmable key and then the "SELECT" key.

#### 4.2.3. "I/O Configuration" submenu.

"I/O Configuration" submenu is accessed, from the drop-down menu "Hardware Configuration", by clicking on the icon:



This submenu allows you to configure the logical audio channels from the physical audio inputs and outputs modules and as previously defined in the "Board Configuration" submenu.

There are two distinct parts in this submenu; upper part of the screen is dedicated to the input channels configuration and the lower part of the screen is for the output channels configuration. In both parts of the screen the tables have the following fields:

- **"Id"**: indicates the equipment internal position of the signal.
- **"Label"**: alphanumeric name of the channel. Maximum number of characters recommended is 6. This is the name that appears in all displays and menus of the AEQ FORUM control surface.
- **"Model"**: type of the physical inputs/outputs module present in the rear panel of the unit. This field will be populated automatically once the "Board Configuration" has been accomplished (see section 4.2.1.1 of this manual).
- **"Config"**: access to advanced settings menu for the selected logical channel. To access, click on **"Click to [CONFIG]"** and then clicking again on the **"Config"** button that will appear.

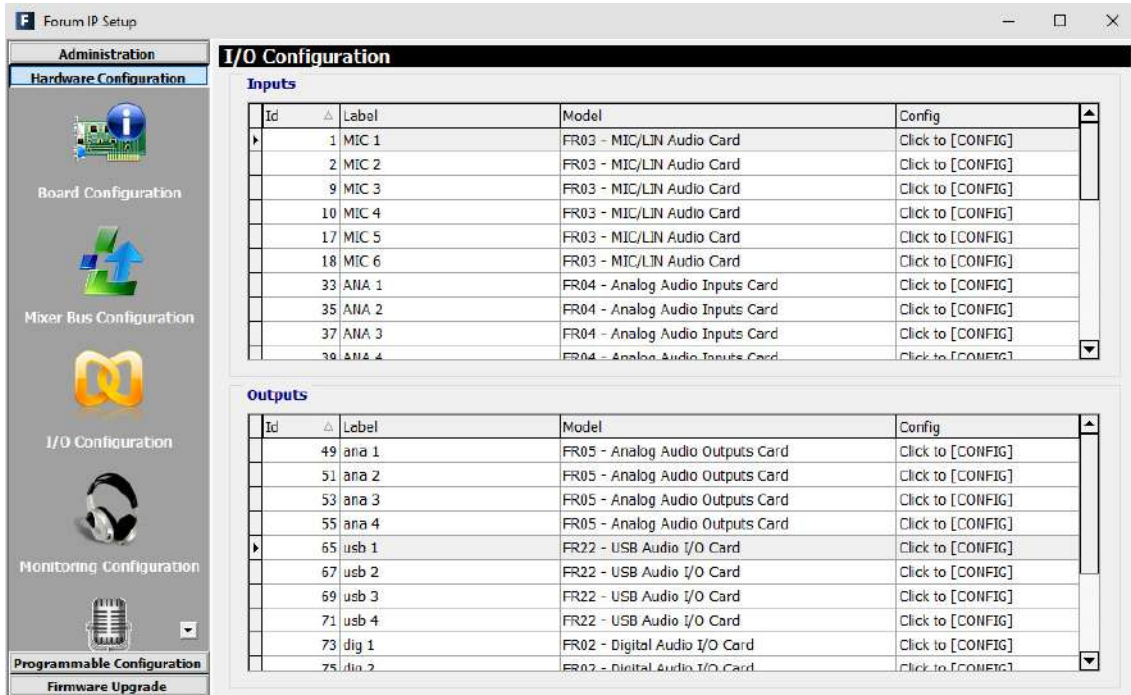

#### 4.2.3.1. Advanced configuration of input channels menu.

Even if all configuration options and possibilities are explained hereunder, it should be taken into account the on-screen options may vary depending on the inputs/outputs module that the logical audio channel has been configured for:

- **Headers:** indicates the type and position of the module that is configured at that moment.
  - **"FRzz Input configuration"** means that we are setting the input of a FR"zz" type card.
  - **"INPUT HW:xx.0y"** means that we are setting the input "y" of the card located in slot xx.
- **"Label":** alphanumeric name of the channel. Maximum number of characters recommended is 6. This is the name that appears on all displays and menus of the AEQ FORUM control surface.
- **"Fader Start":** allows you to select a physical or virtual GPO (from the list defined in section 4.2.1.2) to perform the Fader-start function for this channel. You can not associate the same GPO to several channels. "None" indicates there is no Fader-start function associated with that channel.

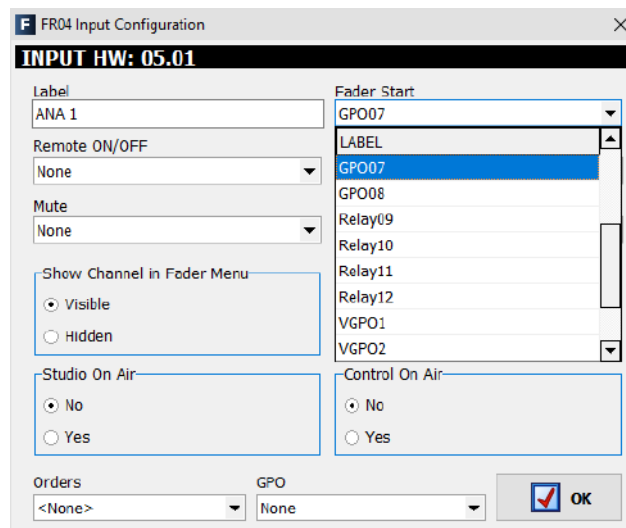

- **"Remote ON/OFF"**: allows you to select a physical or virtual GPI (from the list defined in section 4.2.1.2) to perform the remote start function for this channel (Channel ON/OFF keys on control surface: see paragraph 2.1.1.8 of this manual). "None" indicates there is no Remote ON/OFF function associated with that channel.

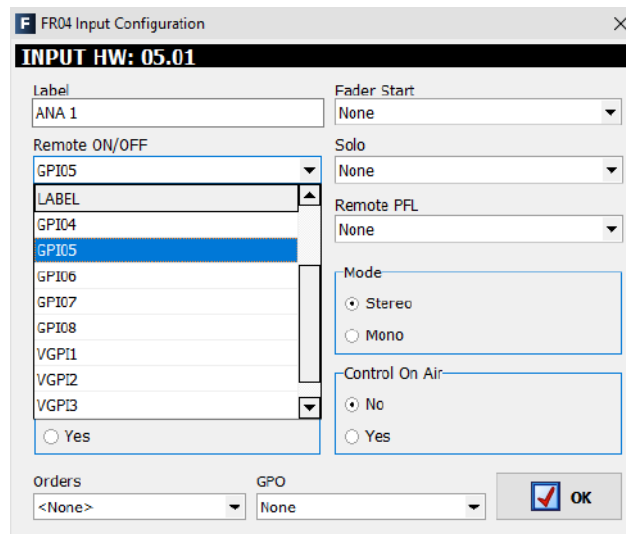

- **"Solo"**: allows you to select a physical or virtual GPI (from the list defined in section 4.2.1.2) to remotely cut the audio of all the inputs except the one that has been associated with the SOLO function. This is useful when for example multiple microphones are used for the invited guests and the moderator needs to cut all the mics except his own. You can not associate the same GPI to several channels. "None" indicates there is no SOLO function associated with that channel.

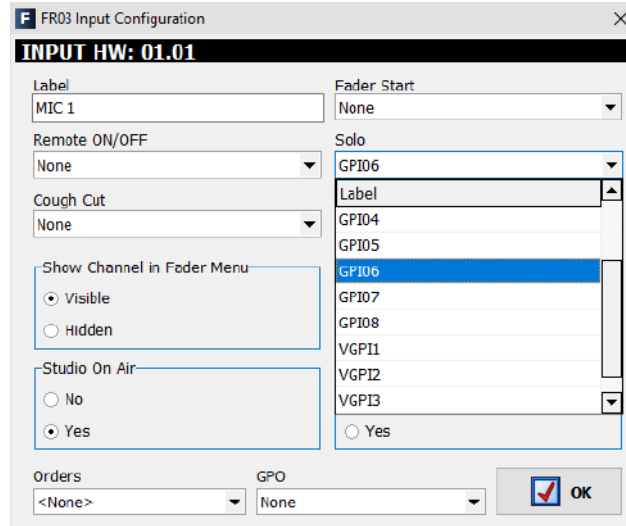

- **"Cough Cut"**: allows you to select a physical GPI (from a wired STUDIOBOX or SCR-03 for instance) or a virtual GPI (from a NETBOX 4 MH for instance), from the list defined in section 4.2.1.2, to perform the cough-cut function for this channel. This option is only available for **microphone** channels. "None" indicates there is no cough-cut function associated with that channel.

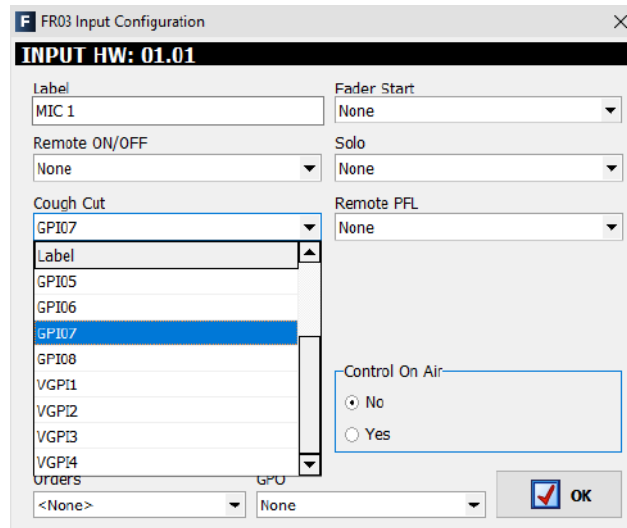

- **"Remote PFL"**: allows you to select a physical GPI (from a wired STUDIOBOX or SCR-03 for instance) or a virtual GPI (from a NETBOX 4 MH for instance), from the list defined in section 4.2.1.2, associated with the sending of the input channel to the CUE output. You can not associate the same GPI to several channels. "None" indicates there is no Remote PFL function associated with that channel.
- **"Mute"**: allows you to select a physical GPI (from a wired push button for instance) or a virtual GPI (from a NETBOX 4 MH, 8 AD or 32 AD for instance), from the list defined in section 4.2.1.2, associated with the function to mute the channel selected upon receiving a remote command. This option is **not** available for **microphone** channels. "None" indicates there is no Mute function associated with that channel.

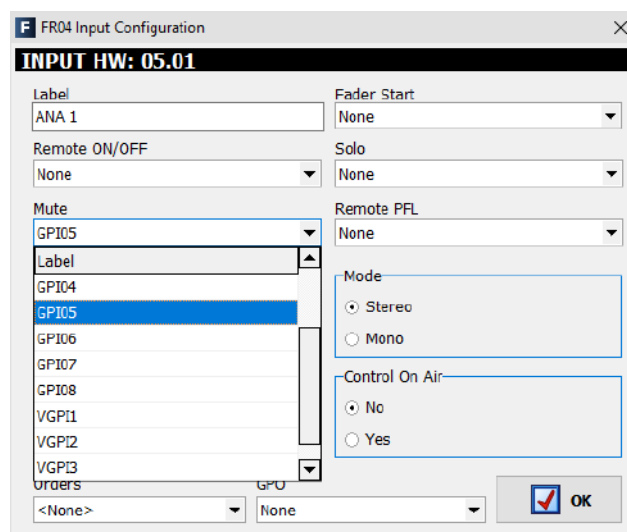

- **"Show Channel in Fader Menu"**: allows you to select whether the selected input channel can be associated ("Visible") or not ("Hidden") to a channel from AEQ FORUM control surface through "FADER" menu (see section 3.4.3.1.3.2). An example of a typically "Hidden" signal would be the time TOPS.
- **"Mode"**: allows you to define whether the selected input channel is Mono or Stereo. By default, all the input channels (except the microphone inputs and the internal telephone hybrid ones) of AEQ FORUM are defined as Stereo. If any channel is re-configured to Mono it will result in an incremented number of the listed available input channels: one Stereo Channel is converted into two Mono channels. This option is **not** available for **microphone** channels and neither for internal **telephone hybrid** channels.

- **"Studio On Air"**: associates the activation of Channel ON/OFF keys of this channel with the triggering of a GPO for the "ON-AIR" lights of the Studio room (see section 4.2.4.1 of this manual). It also associates the studio monitors muting (or attenuation: see section 4.3.2.9 of this manual). Typically, you would associate this function to microphone channels.
- **"Control On Air"**: associates the activation of Channel ON/OFF keys of this channel with the triggering of a GPO for the "ON-AIR" lights of the Control room (see section 4.2.4.1 of this manual). It also associates the muting of the control monitors and the CUE bus. Typically, you would associate this function to auto-control microphone channel.

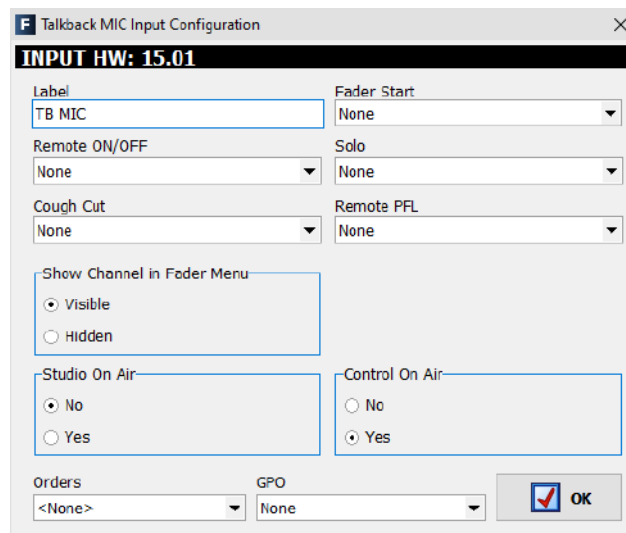

- **"Orders"**: associates an output channel to the selected input channel where you'll send the orders microphone when you press and keep pressed the lower activation key of the control surface channel that input signal is assigned to. In order to work this way, the "Orders" ON/OFF mode must be activated in the corresponding configuration memory or snapshot (for more information, see section 4.3.5 of this manual).

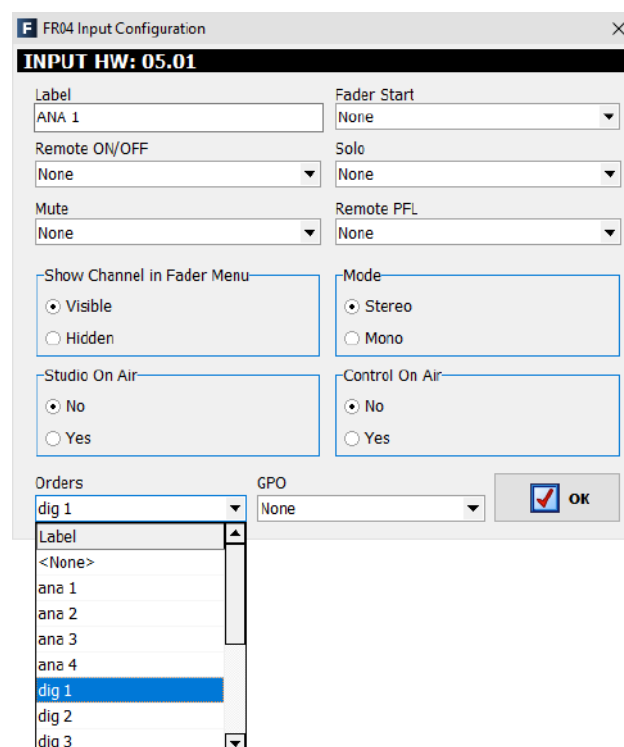

- **"GPO"**: associates a physical or virtual GPO output to the selected input channel that will be activated when you press and keep pressed the lower activation key of the control surface channel that input signal is assigned to (the GPO will be deactivated when you release the key). In order to work this way, the "GPO" ON/OFF mode must be activated in the corresponding configuration memory or snapshot (for more information, see section 4.3.5 of this manual). You can not associate the same GPO to several channels.

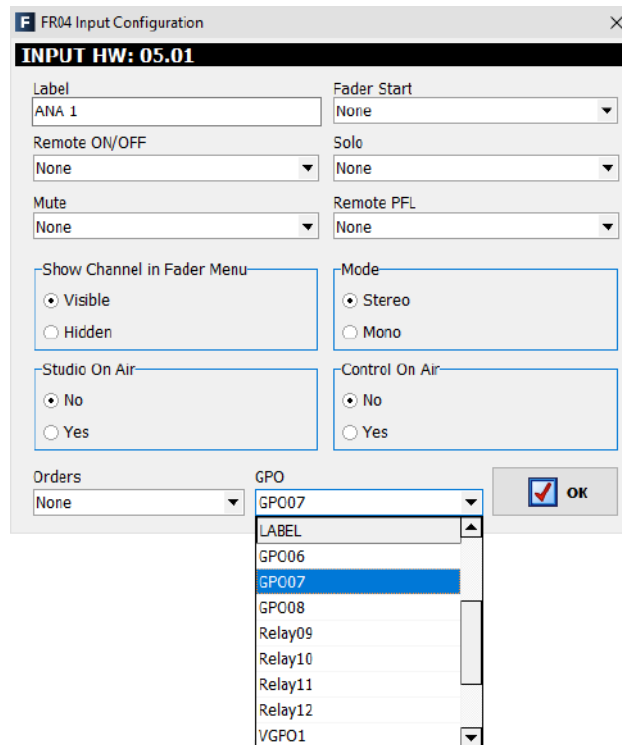

#### 4.2.3.2. Advanced configuration of output channels menu.

Even if all configuration options and possibilities are explained hereunder, it should be taken into account that the on-screen options may vary depending on the inputs/outputs module that the logical audio channel has been configured for.

- **Header**: indicates the position of the module that is configured at that moment.
  - **"OUTPUT HW:xx.0y"** means that we are setting the output "y" of the card located in slot xx.
- **"Label"**: alphanumeric name of the channel. Maximum number of characters recommended is 6. This is the name that appears on all displays and menus of the AEQ FORUM control surface.
- **"Default Routing"**: allows you to configure the signal routed by default to that output channel. You can select any input channel ("Inputs" in "Type" column) or any of the internal summing buses ("Mixer" in "Type" column; see section 4.2.2 of this manual).
- **"Mode"**: allows you to configure the logical output channel as Mono or Stereo. By default, all the outputs channels of AEQ FORUM are defined as Stereo. If any channel is re-configured to Mono it will result in an incremented number of the listed available output channels: one Stereo Channel is converted into two Mono channels. This option is **not** available for internal **telephone hybrid** channels.

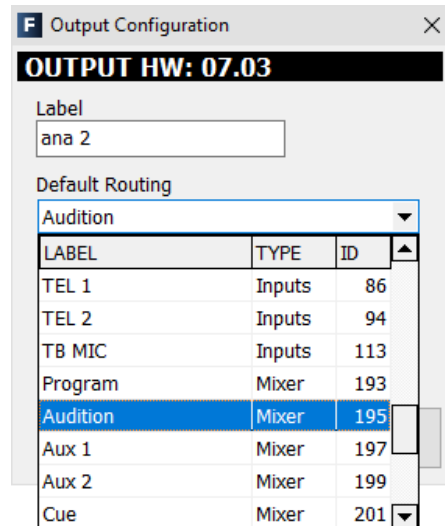
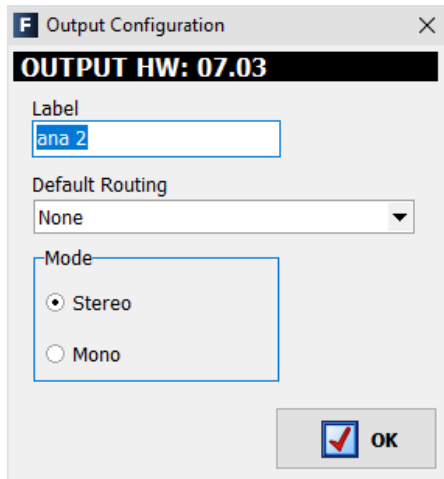

#### 4.2.4. "Monitoring Configuration" submenu.

"Monitoring Configuration" submenu is accessed, from the drop-down menu "Hardware Configuration", by clicking on the icon:



"Monitoring Configuration" submenu allows you to define the operation of the Control and Monitoring sections associated with the control room and the studio room. Please refer to sections 2.1.2.4 and 2.1.2.5 of this manual.



There are two distinct parts in this submenu: the upper part is dedicated to the configuration of the Studio Room section and the lower to the Control Room section.

An example of signalling connection appears in appendix A of this manual.

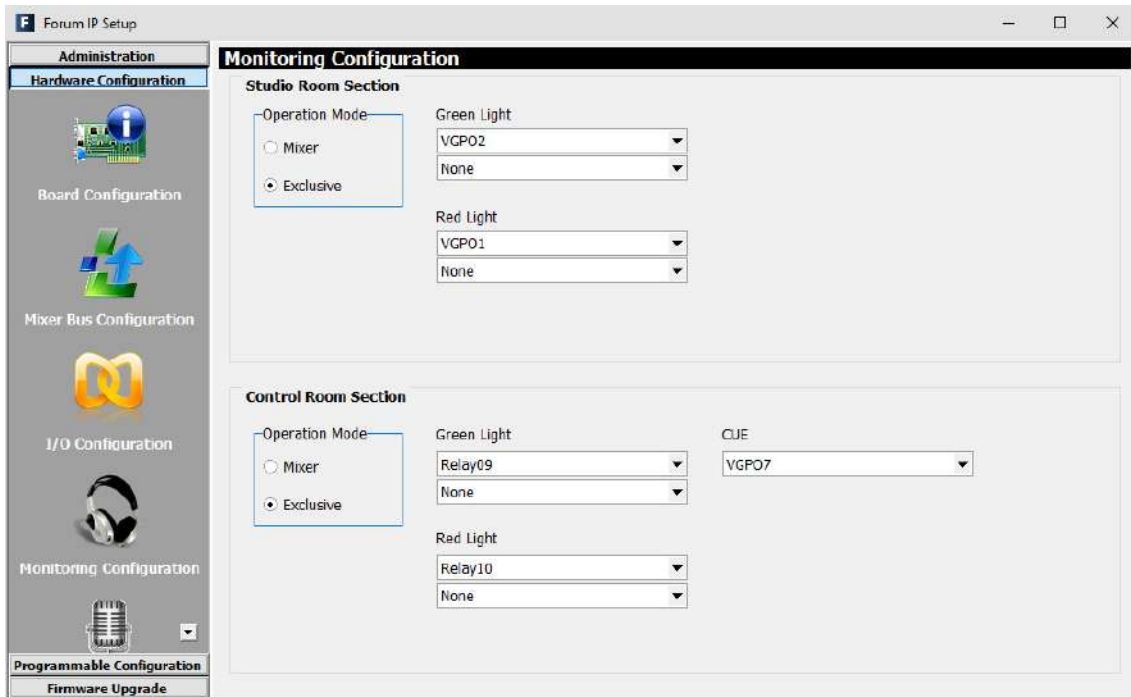

#### 4.2.4.1. "Studio Room Section".

This section of "Monitoring Configuration" submenu lets you choose how the four keys under the display of the **Studio Room** Control and Monitoring section shall work, either in "**Mixer**" or "**Exclusive**". If the option "Mixer" is selected, the output bus associated with "Studio" monitor and headphones will act as a summing bus and therefore may be more than one of the four keys simultaneously activated, thus mixing the signals corresponding to each of the four keys on the studio monitor and headphones. On the other hand, in the "Exclusive" mode, this output bus will not act as a summing bus and therefore may not be more than one key activated at any given time (this effectively means that by pressing any of the four keys, the previously activated one will be disconnected from the summing bus and replaced by the new selection).

In this section you can also assign the **GPO** outputs associated with Studio "OFF AIR" green light (indicates that there are no sources, typically microphones, activated in the studio room) and "ON AIR" red light (indicates that there are sources, typically microphones, activated in the studio room). It's possible to assign **up to 2 GPOs** to each option. You can choose between the opto-coupled GPOs (1 to 8), the virtual GPOs or the contact relay GPOs (9 to 12): these last ones are recommended, except for long distances and shared studios where using virtual GPOs could be a better option. See section 2.2.2.1 of this manual. When a GPO or relay already used is selected, a warning message will appear and a different one must be selected.

The previous image shows an example where the Studio Room lights are managed through virtual GPOs, that may be sent to a NETBOX 4 MH for instance.

#### 4.2.4.2. "Control Room Section".

This section of "Monitoring Configuration" submenu lets you choose how the four keys under the display of the **Control Room** Control and Monitoring section shall work, either in "**Mixer**" or "**Exclusive**". If the option "Mixer" is selected, the output bus associated with "Control" monitor and headphones will act as a summing bus and therefore may be more than one of the four keys simultaneously activated, thus mixing the signals corresponding to each of the four keys on the studio monitor and headphones. On the other hand, in the "Exclusive" mode, this output bus will not act as a summing bus and therefore may not be more than one key activated at any given time (this effectively means that by pressing any of the four keys, the previously activated one will be disconnected from the summing bus and replaced by the new selection).

In this section you can also assign the **GPO** outputs associated with Control "OFF AIR" green light (indicates that there are no sources, typically microphones, activated in the control room) and "ON AIR" red light (indicates that there are sources, typically microphones, activated in the control room). It's possible to assign **up to 2 GPOs** to each option. You can choose between the opto-coupled GPOs (1 to 8), the virtual GPOs or the contact relay GPOs (9 to 12): these last ones are recommended. See section 2.2.2.1 of this manual.

Finally, the "**CUE**" option allows you to select a **GPO** that will be activated when one or more channels are sent to CUE and will remain activated until the last sending to CUE is deactivated or the "CUE RESET" key is pressed.

When a GPO or relay already used is selected, a warning message will appear and a different one must be selected.

The previous image shows an example where the Control Room lights are managed through 2 console relays and the activation of any sending to CUE activates a virtual GPO.

#### 4.2.5. "Visual Radio" submenu.

"Visual Radio" submenu is accessed, from the drop-down menu "Hardware Configuration", by clicking on the icon:



"Visual Radio" functionality allows you to send vumeters of any of the inputs of the unit to a certain IP address. In order to activate this function, you must purchase a user license (see section 4.1.1 of this manual).

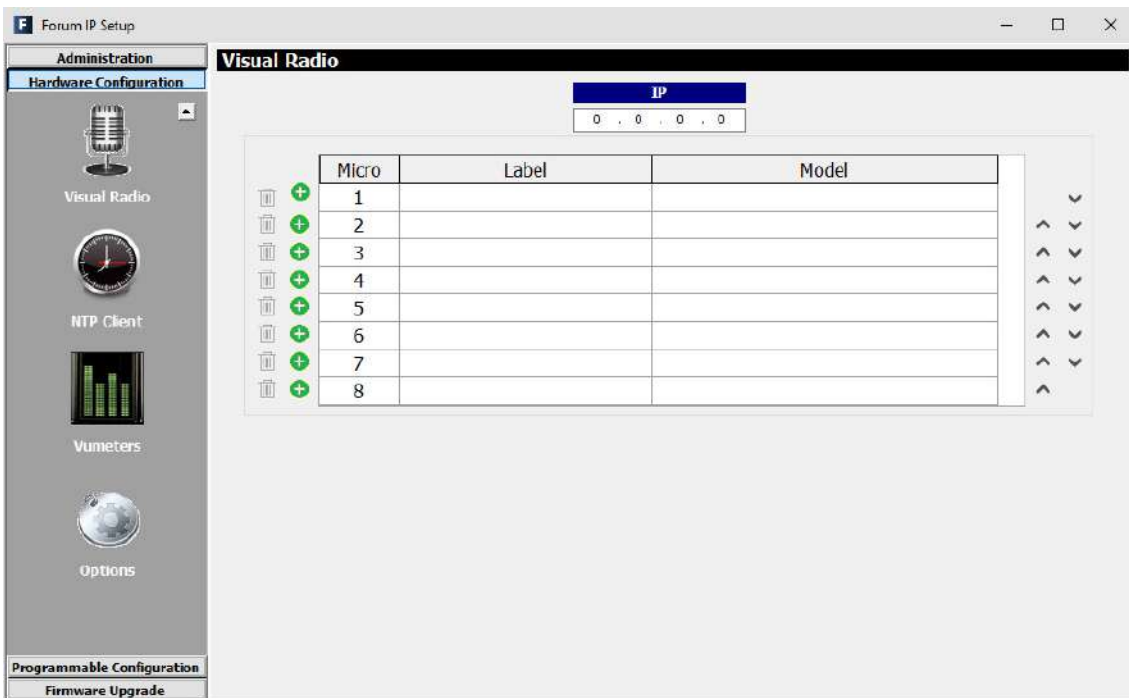

In this submenu first you must configure the destination IP address (it must be in the same subnet of the IP address associated with "ETHERNET" port) and then select the input or inputs of the unit (up to a maximum of 8) whose vumeters will be sent to that IP address.

When you press the button  a list of the available logical inputs of the system will be displayed at the lower part of the screen:

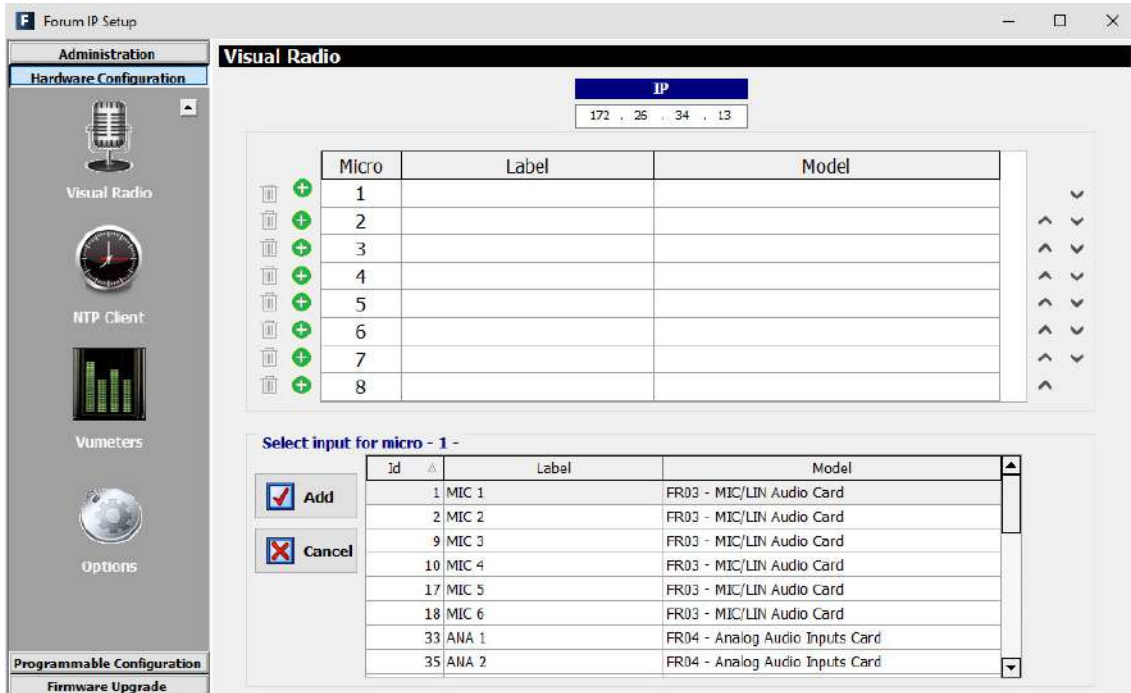

After selecting the desired input and pressing the "Add" button, this input will appear in the list of signals associated with the "Visual Radio" functionality.

The following example shows that the destination IP address is 172.26.34.13 and that the first analog input, the mics 1 and 2 and the first digital input will be sent to that address, with the "Micro" fields from 1 to 4 respectively associated:

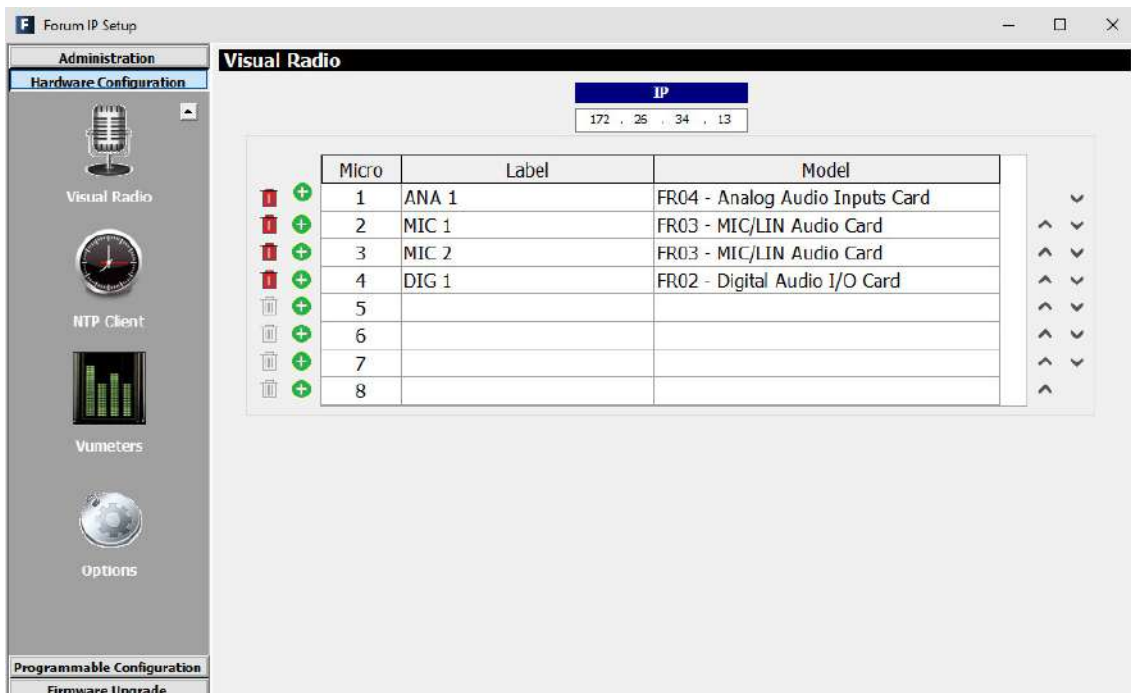

The button  allows you to eliminate any of the configured inputs.

The buttons  allows you to change the order of the listed signals.

#### 4.2.6. "NTP Client Configuration" submenu.

"NTP Client Configuration" submenu is accessed, from the drop-down menu "Hardware Configuration", by clicking on the icon:



"NTP Client Configuration" submenu allows you to enable synchronization of the date and time of the system using standard Ethernet NTP protocol, with the local AEQ FORUM clock slaved to the remote (NTP) signal.

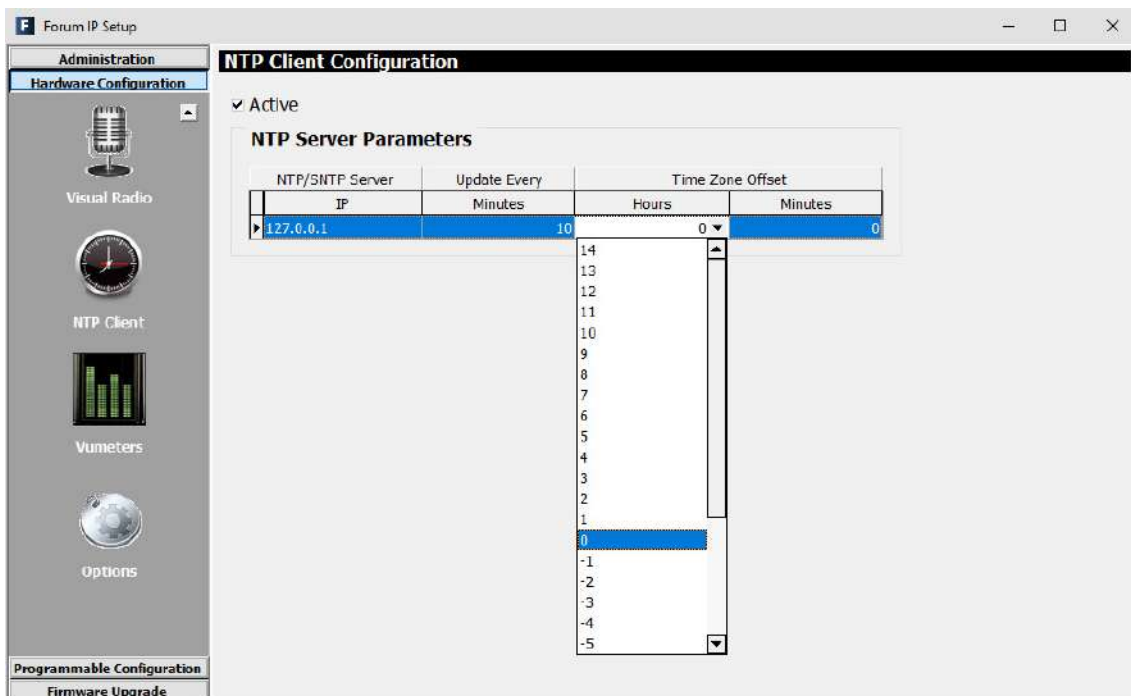

The on-screen options are the following ones (the last 4 ones only appear when the first option is active):

- **"Active"**: allows you to activate or not this option.
- **"NTP/SNTP Server - IP"**: IP address of the server with the remote master clock.
- **"Update Every - Minutes"**: refresh period, the frequency with which AEQ FORUM will contact the remote NTP time server to confirm that there are no deviations. The default value is set to 10 minutes.
- **"Time Zone Offset - Hours"**: allows you to compensate for the difference in time zone(s) between the location of the console and the time zone where the remote NTP clock is located. You can configure this field between -14 and 14 hours.
- **"Time Zone Offset - Minutes"**: allows you to compensate for the difference in time zone(s) between the location of the console and the time zone where the remote NTP clock is located. You can configure this field as 0, 15, 30 or 45 minutes.

#### 4.2.7. "Vumeters" submenu.

"Vumeters" submenu is accessed, from the drop-down menu "Hardware Configuration", by clicking on the icon:



"Vumeters" submenu allows you to configure the vumeters transmission mode and the peakmeter.

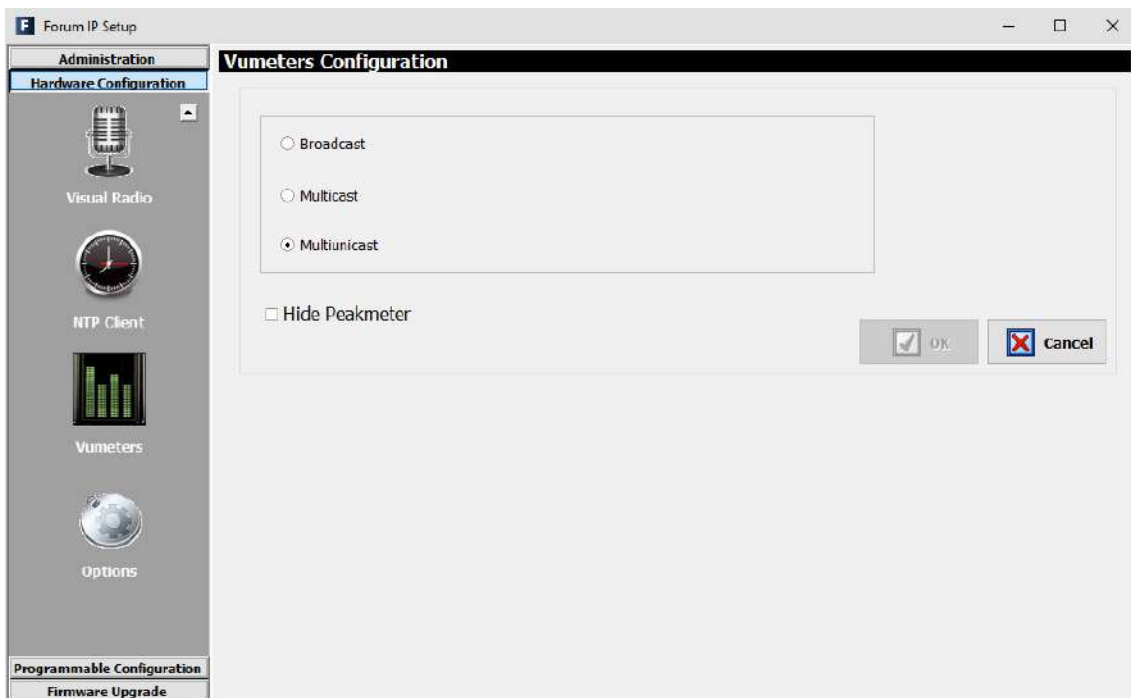

The on-screen options are:

- **"Broadcast"**: allows you to activate the Broadcast vumeters transmission. Vumeters are sent to all the LAN clients but this option would not work for a WAN because the option for distributing Broadcast frames usually is not enabled in routers.
- **"Multicast"**: allows you to activate the Multicast vumeters transmission. When this option is selected a sending group must be configured: Multicast groups are between 224.x.x.x and 239.x.x.x. In this case vumeters are distributed to all the clients subscribed to that Multicast group; routers use to allow Multicast frames, so this option is appropriate for a WAN.

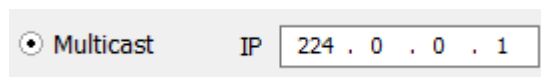

- **"Multiunicast"**: allows you to activate the Multiunicast vumeters transmission (this is the default configuration). In case that Multicast frames are not allowed in a WAN, this option should be used: the console sends UDP unicast frames to each one of the connected clients.

In addition, the **"Hide Peakmeter"** checkbox allows you to activate or not this option (by default, it's deactivated). When activated, the peakmeter of the vumeters is hidden.

#### 4.2.8. "Options" submenu.

"Options" submenu is accessed, from the drop-down menu "Hardware Configuration", by clicking on the icon:



"Options" submenu shows 4 options:

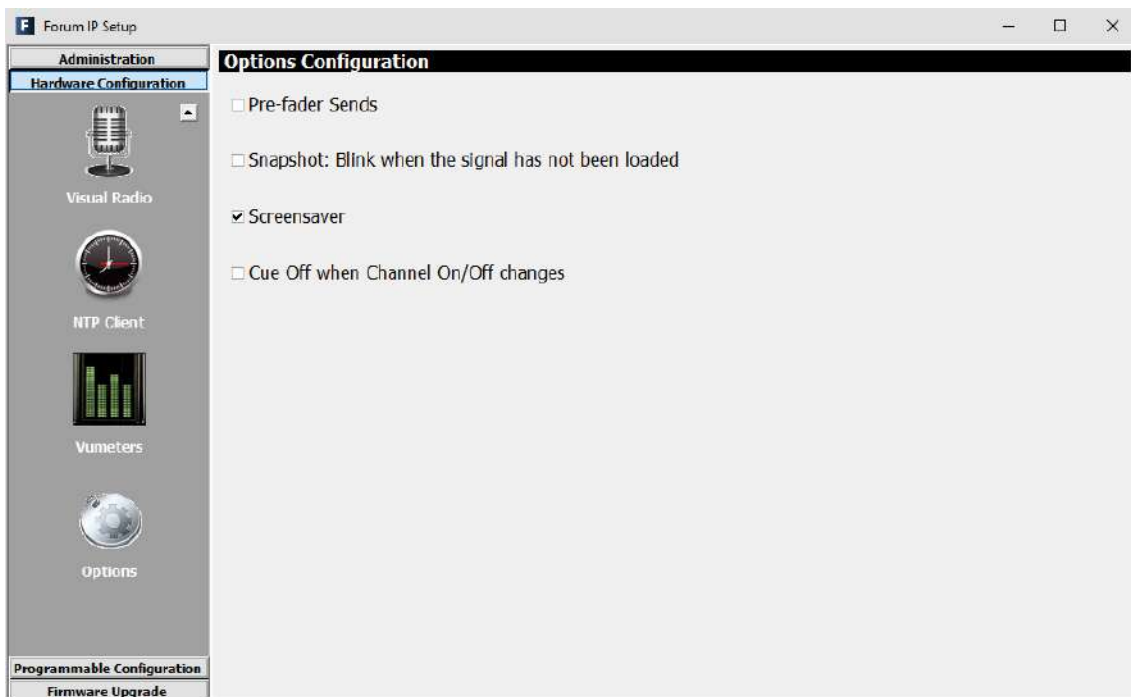

- **"Pre-fader Sends"** checkbox allows you to activate or not this option (by default, it's deactivated), that allows you to configure the operation mode of the sends to the summing buses. When activated, from the "ROUTE" menu (in the main display of the Control and Monitoring section of the control surface) it's possible to unlink the sends of a certain input to the desired system summing buses from the fader, so that the variation of the channel fader doesn't affect those sends level. See section **3.4.3.1.3.3. "ROUTE" menu**.
- **"Snapshot: Blink when the signal has not been loaded"** checkbox allows you to activate or not this option (by default, it's deactivated). As indicated in section 3.3, when a new configuration memory or snapshot is loaded, the audio of the activated channel or channels (ON AIR) will not be interrupted (and the associated routing will remain) provided that in the new memory the activated channel or channels are placed in the same fader positions. When the option "Snapshot: Blink when the signal has not been loaded" is also activated, the upper activation key (the one associated with ON function) of that activated channel or channels will start blinking to indicate that they keep the previous configuration.
- **"Screensaver"** checkbox allows you to activate or not this option (by default, it's activated). When activated, a lateral scroll of the information that appears in channel and monitoring sections displays starts when the control surface enters low lighting mode (after remaining about 5 minutes without being used).

Additionally, from the firmware versions of MSC and FSC of January 2025, when the control surface remains unused for an hour, all LEDs and keys that are on are turned off, the vumeters are turned off and the displays contrast is set to minimum (or turns off, depending on the series of the installed display). This “soft” turn off function can also be performed manually by keeping pressed for 5 seconds the first contextual key (the leftmost one) of the main screen of the control surface.

- **"Cue Off when Channel On/Off changes"** checkbox allows you to activate or not this option (by default, it's deactivated). When activated, if there's a signal sent to CUE, it's deactivated when there is a change in the status of the CHANNEL ON/OFF keys.

### 4.3. "Programmable Configuration" menu.

This menu allows you to configure the internal routing of audio signals and the functions associated with the programmable keys, as well as define mics groups, create processes presets and manage the configuration memories (snapshots) of the unit. Clicking on the section "Programmable Configuration" on the main screen of the configuration software, a list of submenus is deployed on the left side of the workspace which include:

- **"Routing Configuration"**: allows you to define the cross points between input channels or internal summing buses and output channels or internal summing buses.
- **"Programmable Keys"**: allows you to configure the actions associated with each of the 20 physical programmable keys (15 in the case of **FORUM** and **FORUM V2**) that are located in the Control and Monitoring section of AEQ FORUM IP control surface and each of the 100 virtual programmable keys (75 in the case of FORUM and FORUM V2).
- **"Mic Group Configuration"**: allows you to define microphone groups.
- **"Preset Configuration"**: allows you to create default settings associated with the various processing capabilities of AEQ FORUM: equalizers, filters, compressors/limiters and noise gates.
- **"Snapshot Configuration"**: allows you to manage the configuration memories stored in the unit.

In order to access to any of these submenus, it's necessary to have a configuration loaded in the application: in case there's no configuration, the message **"Empty configuration. Please read configuration before use"** would be displayed and you should have to either connect to AEQ FORUM console and read its configuration or load a configuration by means of "Import" option (see section 4.1.1 of this manual; you can find the "DemoConfiguration.FSC" file in C:\Program files\ForumSetup\Demos).

#### 4.3.1. "Routing Configuration" submenu.

"Routing Configuration" submenu is accessed, from the drop-down menu "Programmable Configuration", by clicking on the icon:



"Routing Configuration" submenu allows you to define the cross-points between input channels or internal summing buses and output channels or internal summing buses. The entire set of cross-points available on the mixing console is arranged in a table with the following fields:

- **"Id Source"**: internal numeric identifier for the input channel or summing bus.
- **"Source"**: "Label" of the input channel or summing bus. Please refer to sections 4.2.2 and 4.2.3 of this manual.

- **"Type"**: type of channel used in the cross-point: "Input" for input channels and "Mixer" for internal summing buses.
- **"Id Destination"**: internal numeric identifier for the output channel or summing bus.
- **"Destination"**: "Label" of the output channel or summing bus. Please refer to sections 4.2.2 and 4.2.3 of this manual.

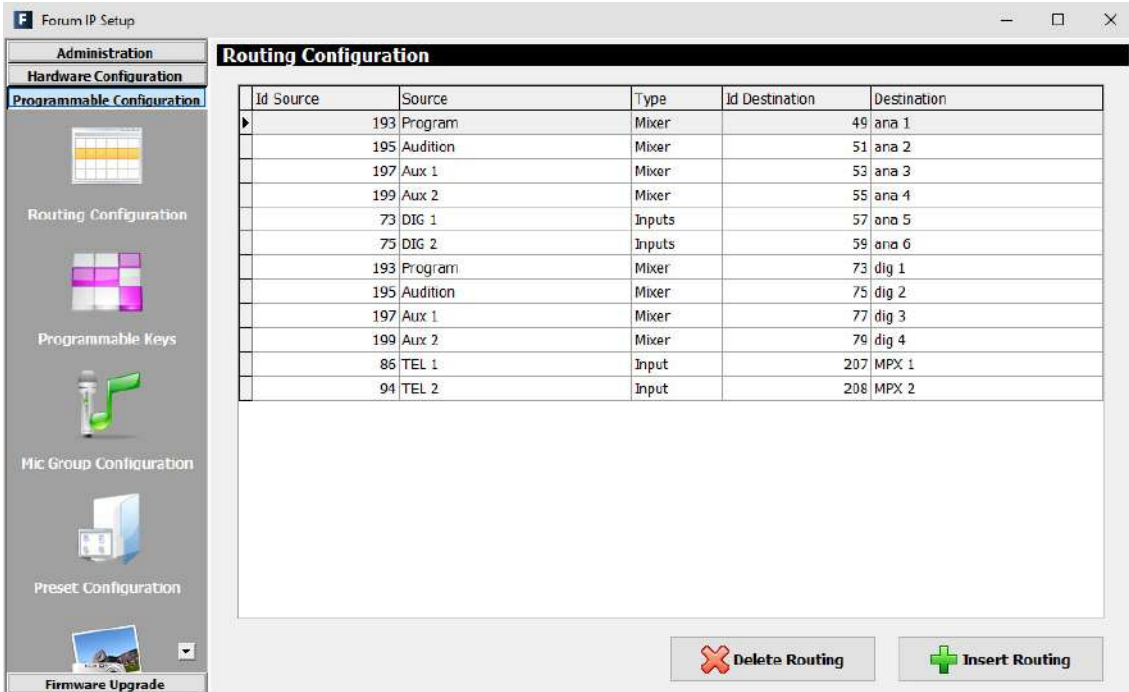

The bottom of the workspace in this submenu contains two options:

- **"Delete Routing"**: eliminates the selected cross-point. Confirmation is requested.

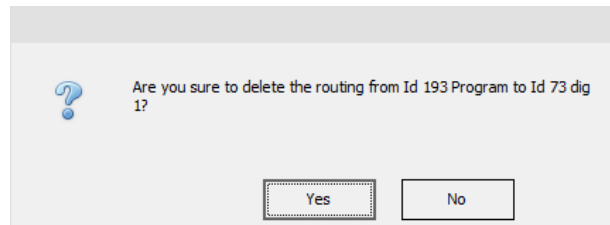

- **"Insert Routing"**: you can create a cross-point through a simple process that allows you to select an input channel or an internal summing bus as the source, and an output channel or an internal summing bus as the destination. These names or labels have been previously defined in the "I/O Configuration" submenu.

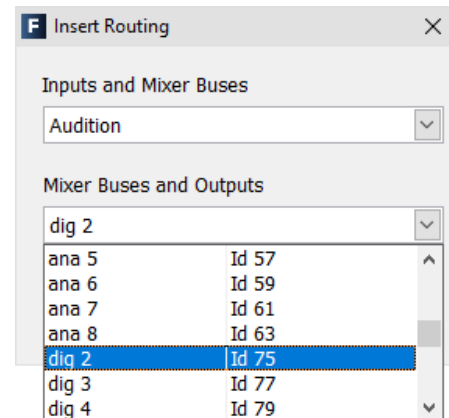
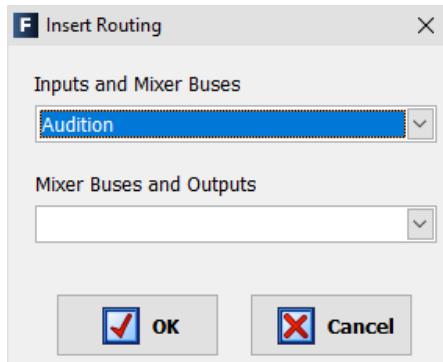

**IMPORTANT NOTE:** For firmware versions 1.73 of CPU and 1.31 of DSP Router or higher, the routing toward MPX internal summing buses is saved on console configuration and it will appear in the "Routing Configuration" submenu when the active configuration is read.

#### 4.3.2. "Programmable Keys" submenu.

"Programmable Keys" submenu is accessed, from the drop-down menu "Programmable Configuration", by clicking on the icon:



"Programmable Keys" submenu lets you configure the actions associated with each of the 20 physical programmable keys (15 in the case of **FORUM** and **FORUM V2**) found in the Control and Monitoring section of the AEQ FORUM IP control surface (please refer to section 2.1.2.2 of this manual) and each of the 100 virtual programmable keys (75 in the case of FORUM and FORUM V2).

**IMPORTANT NOTE:** There is an edition of the board that form the control and monitoring section with the control VU meters and the programmable keys placed in horizontal position, instead of vertical. For this board edition there is a specific version of configuration application (**Forum Setup**) with the programmable keys placed that way.

Within this submenu there are two distinct areas:

- **"Keyboard"**: it's the upper part of the screen that allows for the basic configuration of the 20 physical programmable keys and the 100 virtual programmable keys (15 and 75 respectively in the case of **FORUM** and **FORUM V2**). In the right part of the screen, you can select if physical or virtual keys will be configured (the virtual ones are divided into 5 groups of 20 keys, 15 in the case of FORUM and FORUM V2).
- **"Key Configuration"**: it's the lower part of the screen where the specific configuration of the selected programmable key is accomplished.

The **"Edit Label"** button allows you to assign a label to the programmable key in order to identify it in **"Forum Virtual"** application (this option is available from version **1.63** of that application). When pressed it changes to:

The field on the left allows you to enter the desired label (a maximum of 9 characters is recommended) and the buttons on the right accept or reject the change.

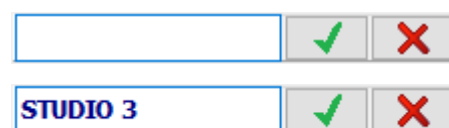

When change is accepted, it appears like this. By pressing "Edit Label" again it's possible to change it.

STUDIO 3

Edit Label

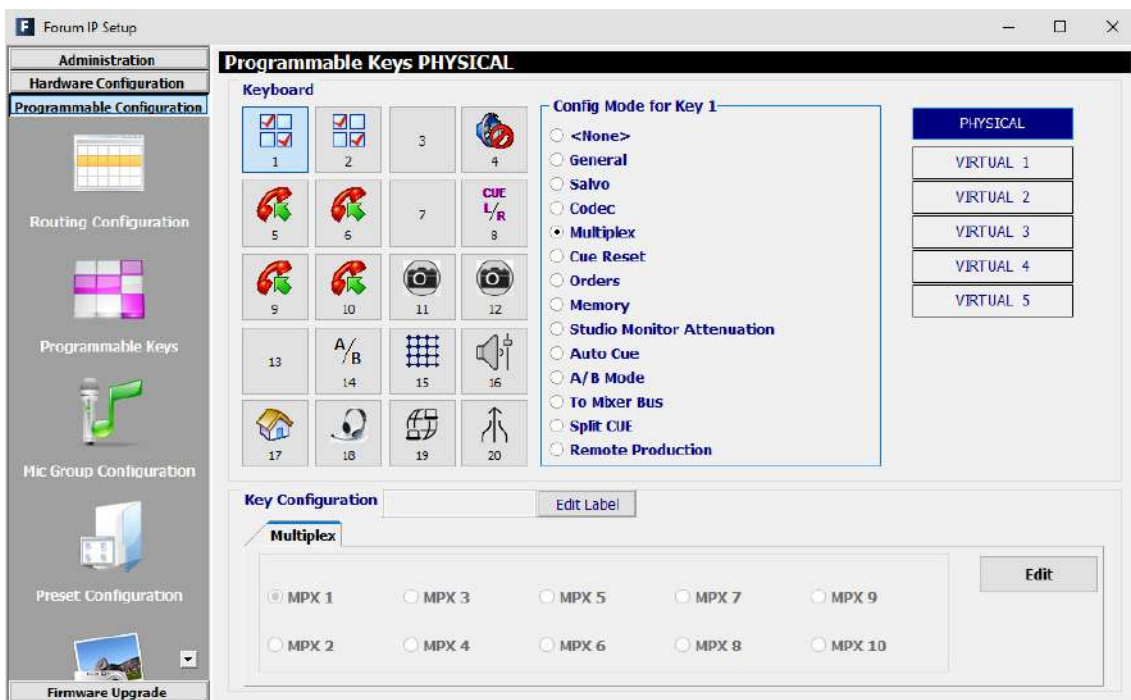

#### 4.3.2.1. Basic configuration of programmable keys.

This basic configuration section shows graphically the programmable keys corresponding to the Control and Monitoring section of the AEQ FORUM IP control surface. The programmable keys are numbered from 1 to 20 (from 1 to 15 in the case of **FORUM** and **FORUM V2**) following the order from left to right and top to bottom.

To set a programmable key, simply click on it with the mouse and select from the list on the right to associate action. The available options are:

- **"None"**: no action associated.
- **"General"**: associated with activation of physical or virtual GPIs and/or GPOs.
- **"Salvo"**: allows you to configure activation/deactivation of a Salvo.
- **"Codec"**: associated with remote control of external communications equipment through physical or virtual GPIs and GPOs.
- **"Multiplex"**: allows you to make a quick management of signal routing toward an "MPX" type internal summing bus (these buses are typically used for sending to codecs, hybrids or other auxiliary destinations).
- **"Cue Reset"**: allows you to cancel all the signals sending to the CUE bus at that moment.
- **"Orders"**: allows you to send the orders microphone to the selected output channel.
- **"Memory"**: allows you to load the selected configuration memory or snapshot.
- **"Studio Monitor Attenuation"**: allows you to replace the studio monitors muting when a studio microphone is activated with a programmable attenuation (-10dB, -15dB or -20dB) of those monitors level.
- **"Auto Cue"**: allows you to modify the working mode of the signals sending to the CUE bus and the control monitoring.
- **"A/B Mode"**: allows you to activate the A/B working mode.
- **"To Mixer Bus"**: allows you to make a quick management of signal routing toward an "Internal" type summing bus.

- **"Split CUE"**: allows you to activate/deactivate the sending of the CUE bus to one of the channels of the control monitoring.
- **"Remote Production"**: allows you to dynamically configure the signal to be used as orders/autocontrol microphone, as well as an audio output for remote monitoring.

In the case of the **virtual** programmable keys, only the **first 3 options** are available. As its name implies, these keys will not be physically available on the control surface and will have associated actions that will be activated by means of physical or virtual GPIs.

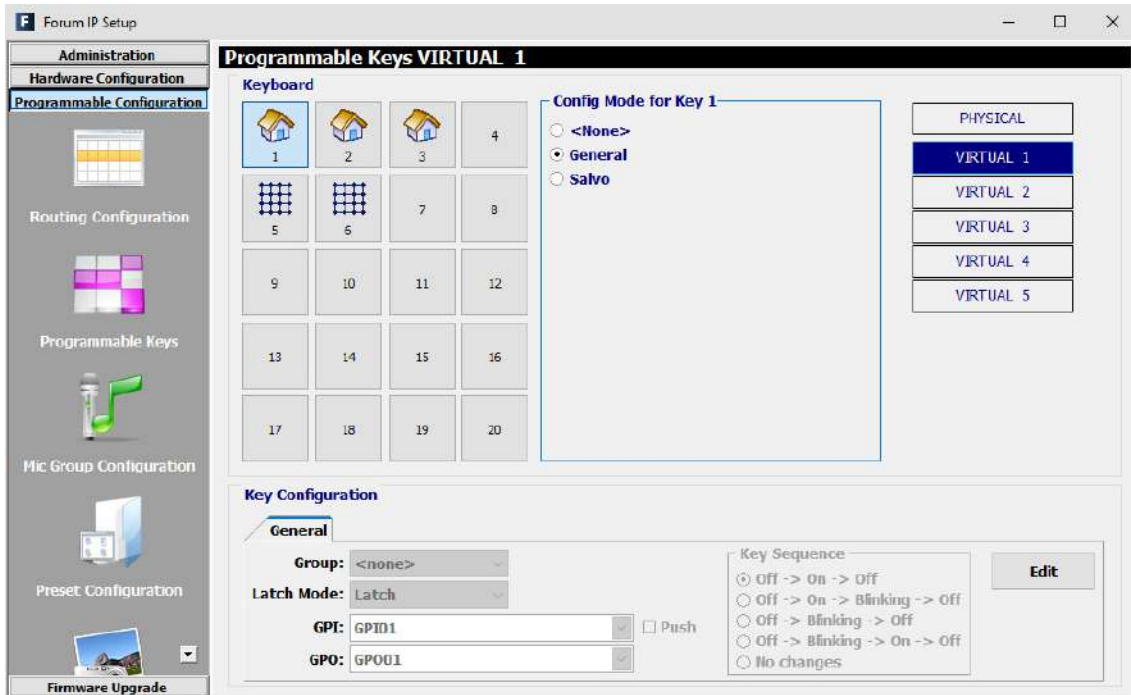

#### 4.3.2.2. Configuration of "General" programmable keys.

Programmable keys that are set to "General" are used to activate GPIs and GPOs. A key set to this function is assigned with a dedicated icon.



The lower part of the "Programmable Keys" submenu will show the associated options for "General" type keys, when this configuration mode is selected:

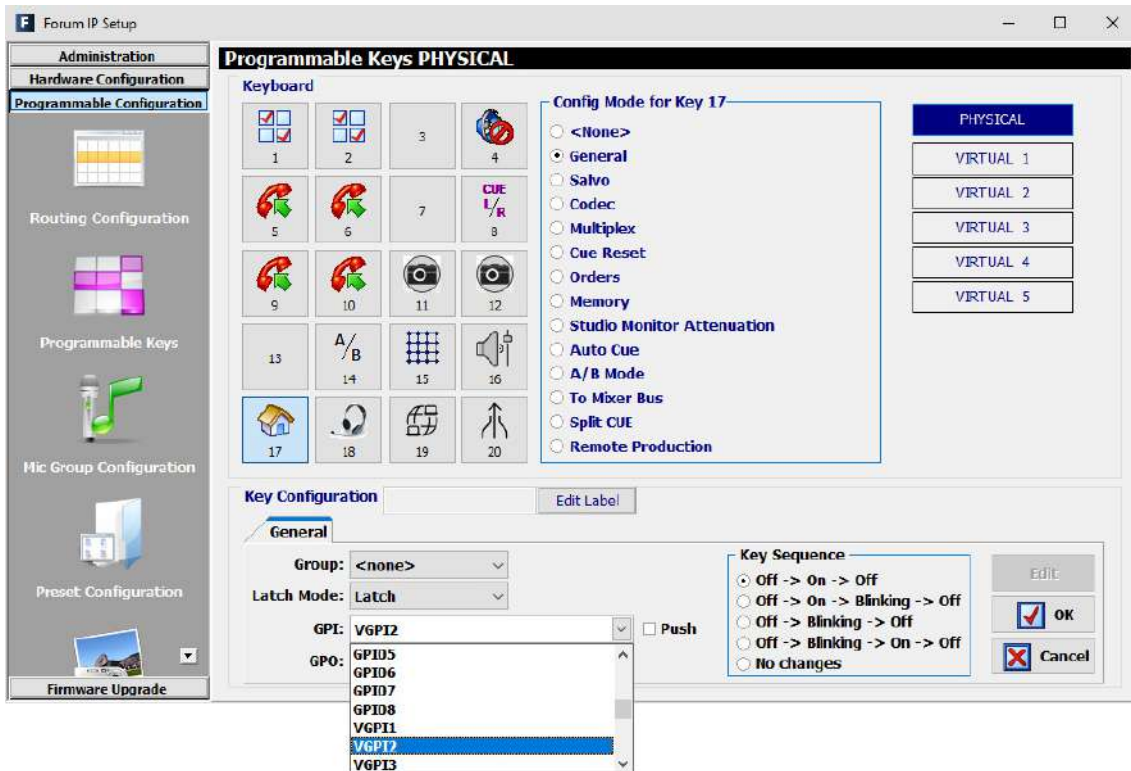

In order to be able to configure the programmable key (or edit a previously created configuration), you have to press the "Edit" button, to active and allows you to configure the following fields:

- **"Group"**: allows you to assign the programmable key to a group. Assign a key to a group when you need to define exclusive operation between various programmable keys (the activation of one of them entails the deactivation of the one active at that moment). You can create up to 8 programmable keys groups. "None" indicates that key is not assigned to a group.
- **"Latch Mode"**: allows you to configure the key as "Latch" or "Non Latch", so after you press it, the key stays fixed or not. When a key is configured as "Non Latch", it executes the associated function only while it remains pressed.
- **"GPI"**: allows you to select the physical or virtual GPI input, in the section of system common I/O's, associated with the programmable key activation.
- **"Push"**: when you associate a GPI and a GPO to the same key and you activate this checkbox, the GPO is automatically activated when GPI is received. When "Push" checkbox is not active, this automatic activation is not made. Any of them can be physical or virtual.
- **"GPO"**: allows you to select the physical or virtual GPO output, in the section of system common I/O's, associated with the programmable key activation. When a GPO already used is selected, a warning message will appear.
- **"Key Sequence"**: allows you to select the operating sequence of the programmable key:
  - **"Off-On-Off"**: initially the key is off, it turns on when the programmable key is pressed (or when the associated GPI is activated) and off when it's pressed again (or when the GPI is deactivated). From this point the cycle is re-initiated.
  - **"Off-On-Blinking-Off"**: initially the key is off, it turns on when the programmable key is pressed, starts blinking when the key is pressed again and turn off when it's pressed again. From this point the cycle is re-initiated.

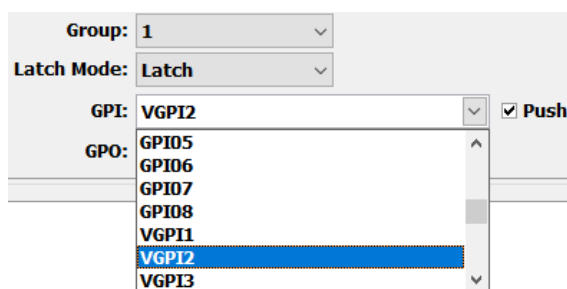

When activation is through an associated GPI, the key turns on when the GPI is activated and starts blinking when it's deactivated.

- **"Off-Blinking-Off"**: initially the key is off, it starts blinking when the programmable key is pressed (or when the associated GPI is activated) and off when it's pressed again (or when the GPI is deactivated). From this point the cycle is re-initiated.
- **"Off-Blinking-On-Off"**: initially the key is off, it starts blinking when the programmable key is pressed, turns on when the key is pressed again and turn off when it's pressed again. From this point the cycle is re-initiated. When activation is through an associated GPI, the key starts blinking when the GPI is activated and turns off when it's deactivated.
- **"No changes"**: this option is exclusively associated with GPIs. The key turns on when GPI is activated and keeps on until that GPI is deactivated, even if the key is pressed.
- **"OK"**: allows you to accept the created or edited configuration.
- **"Cancel"**: allows you to reject the created or edited configuration. No change you may have made is saved.

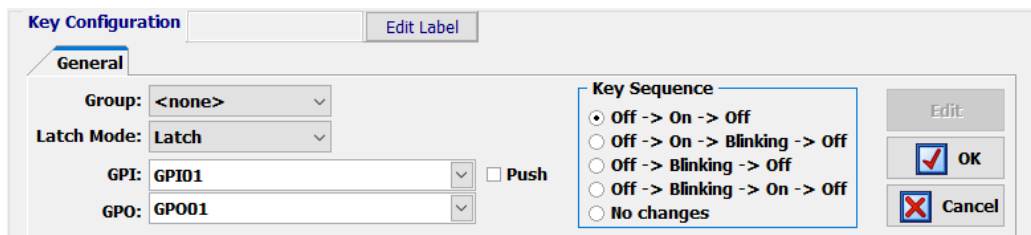

The image shows the 'Key Configuration' dialog box with the 'General' tab selected. It includes fields for 'Group' (set to '<none>'), 'Latch Mode' (set to 'Latch'), 'GPI' (set to 'GPI01'), and 'GPO' (set to 'GPO01'). There is a 'Push' checkbox which is currently unchecked. The 'Key Sequence' section has five radio button options: 'Off -> On -> Off' (selected), 'Off -> On -> Blinking -> Off', 'Off -> Blinking -> Off', 'Off -> Blinking -> On -> Off', and 'No changes'. Action buttons for 'Edit', 'OK', and 'Cancel' are also visible.

In the case of the **virtual** programmable keys, only the "GPI" that will activate the key and the associated "GPO" should be configured. Besides, the "Push" checkbox must be activated.

#### 4.3.2.3. Configuration of "Salvo" programmable keys.

Programmable keys that are set to "Salvo" are used to activate/deactivate a Salvo or group of connections and/or disconnections of several cross-points. A key set to this function is assigned with a dedicated icon.

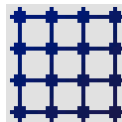

The lower part of the "Programmable Keys" submenu will allow you to configure the Salvo content.

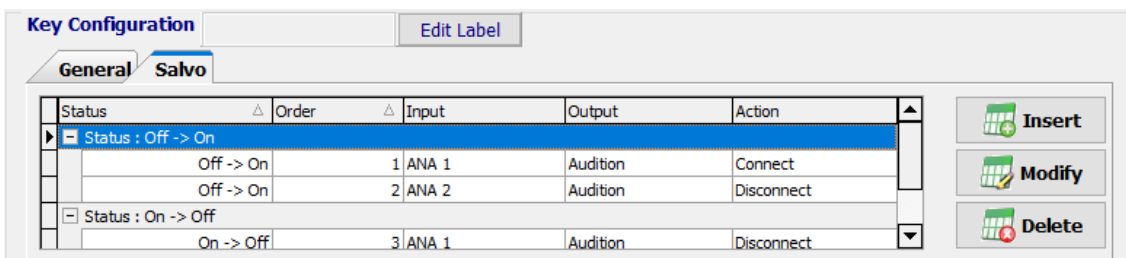

The image shows the 'Key Configuration' dialog box with the 'Salvo' tab selected. It displays a table with columns for 'Status', 'Order', 'Input', 'Output', and 'Action'. The table contains three rows of configuration data. To the right of the table are three buttons: 'Insert', 'Modify', and 'Delete'.

Status	Order	Input	Output	Action
Status : Off -> On				
Off -> On	1	ANA 1	Audition	Connect
Off -> On	2	ANA 2	Audition	Disconnect
Status : On -> Off				
On -> Off	3	ANA 1	Audition	Disconnect

There are two tabs: **"General"** and **"Salvo"**.

The **"General"** tab gives you access to a screen identical to the one described in the previous section and allows you to configure the operational sequence of the programmable key and its relationship with the system GPIs and GPOs. This way it is possible to execute a Salvo by pressing the programmable key and activating at the same time a GPO or by the remote

activation of the programmable key through GPI (for this purpose, you must activate the "Push" checkbox). When a GPO already used is selected, a warning message will appear.

The only difference in this tab with respect to the "General" type programmable keys is that the "HW Switch" option appears, which allows you to assign this working mode to a group of keys:

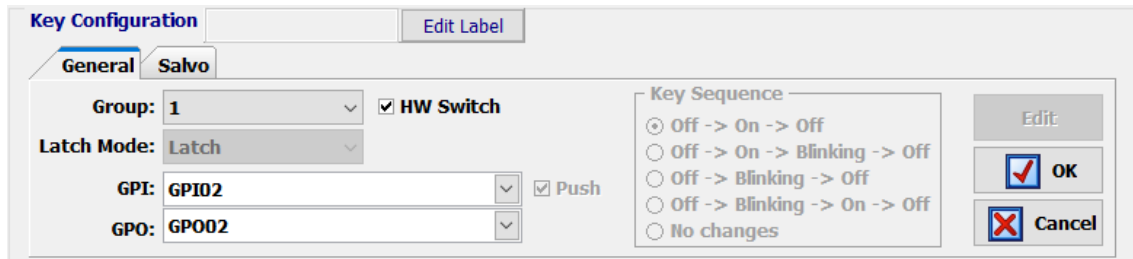

In order to activate this option, the programmable key must be assigned to a group. When activated, there are certain fields that are configured by default and cannot be modified: "Latch Mode" is configured as "Latch", "Push" is activated and "Key Sequence" is configured as "Off-On-Off". When you activate/deactivate the "HW Switch" option on a key and validate by pressing "OK", in the other programmable keys of "Salvo" type that belong to the same group, that option is automatically activated/deactivated and the configuration of the three previous fields is replicated.

The "Salvo" tab includes specific functions, including a list of actions for each of the cross-points controlled by the Salvo and the order of execution (first-up, last-down). There are three buttons below the list enabling you to configure the list of actions:

- "Insert": allows you to insert the activation or deactivation of a cross-point in the list of actions from a simple menu:
  - "Status":
    - "Off → On": the action is executed when the programmable key is activated.
    - "On → Off": the action is executed when the programmable key is deactivated.
  - "Order": allows you to set the position of this action in the general list of actions.
  - "Input": allows you to select the input channel or internal summing bus.
  - "Output": allows you to select the output channel or internal summing bus.
  - "Action": allows you to select whether the cross-point between "Input" and "Output" is connected ("Connect") or disconnected ("Disconnect").

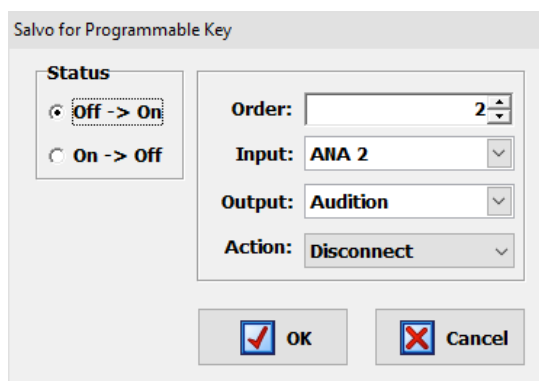

- "Modify": allows you to modify a preconfigured action. The options on this screen are identical to those described for "Insert" option.
- "Delete": allows you to delete a preconfigured action. Confirmation is requested.

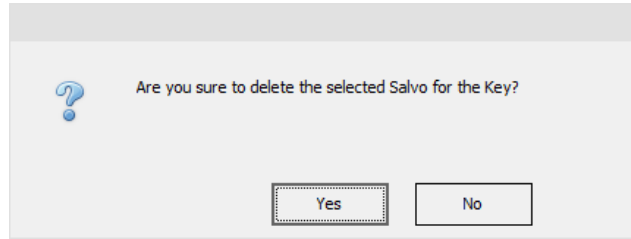

In the case of the **virtual** programmable keys, at least the "GPI" that will activate remotely the key to execute the Salvo should also be configured.

#### 4.3.2.4. Configuration of "Codec" programmable keys.

Programmable keys that are set to "Codec" enables you to assign functions associated with remote control of external communications equipment (such as audiocoders) through associated physical or virtual GPIs and GPOs. A key set to this function is assigned with a dedicated icon.



The lower part of the "Programmable Keys" submenu will show the associated options for "Codec" type keys, when this configuration mode is selected.

In order to be able to configure the programmable key (or edit a previously created configuration), you have to press the **"Edit"** button, to active and allows you to configure the following fields:

- **"Device"**: it shows a list of pre-programmed devices in the "Codec" function. The available options are:
  - **"FR33"**: optional internal digital telephone hybrid module of AEQ FORUM. For more information see section 2.2.3.5 of this manual.
  - **"TH02"**: digital telephone hybrid AEQ TH02EX. For more information, please consult the AEQ website.
  - **"Eagle"**: ISDN audiocodex AEQ EAGLE. For more information, please consult the AEQ website.
  - **"Phoenix"**: IP/ISDN audiocodex AEQ PHOENIX Studio, Stratos, Venus, Venus V2, Venus V3 or Venus V4. For more information, please consult the AEQ website.

Depending on the particular equipment selected, the following options may vary. For **FR33** module, the available options are:

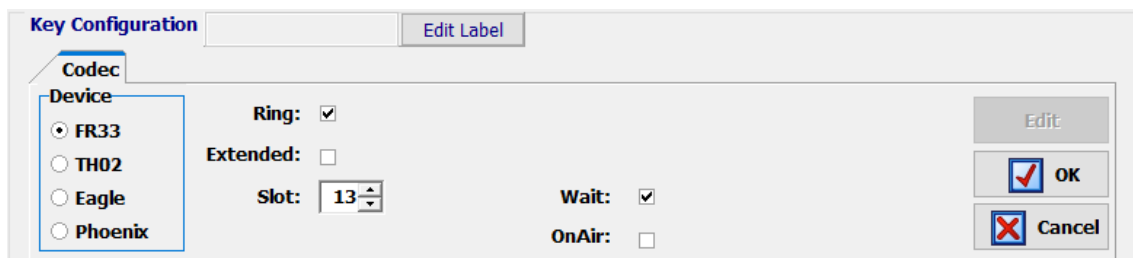

- **"Ring"**: the key starts to blink when there is an incoming call. This function can be combined in the same key with any of the following three functions.
- **"Extended"**: enables the option of frequency extender for the FR33 telephone hybrid. The key turns on when activated.

- **"Wait"**: allows you to put the call on hold (you can send audio to the telephone line, but the audio from the line is not received in the console). The key turns on when activated.
- **"OnAir"**: allows you to put the call on the air (you can send audio to the telephone line and the audio from the line is received in the console). The key turns on when activated.
- **"Slot"**: allows you to configure the position (between 1 and 14) on the rear panel of AEQ FORUM where FR33 module has been installed.
- **"OK"**: allows you to accept the created or edited configuration.
- **"Cancel"**: allows you to reject the created or edited configuration. No change you may have made is saved.

**IMPORTANT NOTE:** "Extended", "Wait" and "OnAir" functions are exclusive between them (a programmable key can have only one of the three options associated), although any of them can be combined in the same key with "Ring" function.

For **TH02** hybrid, the available options are:



- **"Ring"**: allows you to select the GPI where the incoming call signal provided by the hybrid is wired. The key starts to blink when there is an incoming call. This function can be combined in the same key with any of the following three functions.
- **"Extended"**: enables the option of frequency extender for the TH02 telephone hybrid and select the GPO used to send the remote control signal to the hybrid. The key turns on when activated.
- **"Wait GPO"**: selects and configures the physical GPO output associated with "WAIT" function. The key turns on when activated and puts the call on hold (WAIT mode).
- **"On Air GPO"**: selects and configures the physical GPO output associated with "ON AIR" function. The key turns on when activated and puts the call on the air (ON AIR mode).
- **"Line"**: for dual line hybrids such as TH02, this identifies the integrated line 1 and line 2, to assign the different GPIs and GPOs for remote control
- **"OK"**: allows you to accept the created or edited configuration.
- **"Cancel"**: allows you to reject the created or edited configuration. No change you may have made is saved.

**IMPORTANT NOTE:** "Extended", "Wait GPO" and "OnAir GPO" functions are exclusive between them (a programmable key can have only one of the three options associated), although any of them can be combined in the same key with "Ring" function. In addition, when a GPO already used is selected, a warning message will appear.

For **Eagle** audiocodec, the available options are:

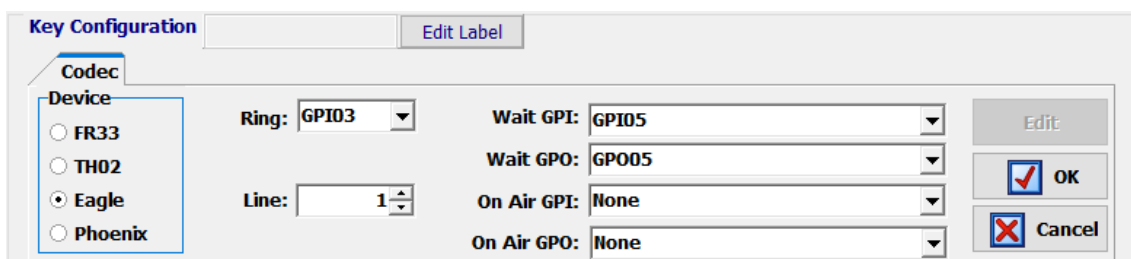

- **"Ring"**: allows you to select the GPI where the incoming call signal provided by the codec is wired. The key starts to blink when there is an incoming call. This function can be combined in the same key with any of the following four functions.
- **"Wait GPI"**: selects and configures the physical GPI input associated with "WAIT" function. The key turns on when WAIT mode (call on hold) is activated manually in the audiocodec.
- **"Wait GPO"**: selects and configures the physical GPO output associated with "WAIT" function. The key turns on when activated and puts the call on hold (WAIT mode).
- **"On Air GPI"**: selects and configures the physical GPI input associated with "ON AIR" function. The key turns on when ON AIR mode (call on the air) is activated manually in the audiocodec.
- **"On Air GPO"**: selects and configures the physical GPO output associated with "ON AIR" function. The key turns on when activated and puts the call on the air (ON AIR mode).
- **"Line"**: for dual line codecs such as Eagle, this identifies the integrated line 1 and line 2, to assign the different GPIs and GPOs for remote control.
- **"OK"**: allows you to accept the created or edited configuration.
- **"Cancel"**: allows you to reject the created or edited configuration. No change you may have made is saved.

**IMPORTANT NOTE:** The pairs of functions "Wait GPI"- "Wait GPO" and "On Air GPI"- "On Air GPO" are exclusive between them (a programmable key can have only one of the two pairs associated). In addition, when a GPO already used is selected, a warning message will appear.

For codecs it is usual to program at least two programmable keys per channel: one to share "Ring", "Wait GPI" and "Wait GPO" functions and another one to share "On Air GPI" and "On Air GPO" functions. The following screens show an example of programmable keys configuration for remote control of an AEQ EAGLE audiocodec.



**Key Configuration** Edit Label

Codec

Device

FR33

TH02

Eagle

Phoenix

Ring: GPI03

Line: 1

Wait GPI: GPI05

Wait GPO: GPO05

On Air GPI: None

On Air GPO: None

Edit

OK

Cancel

1

**Key Configuration** Edit Label

Codec

Device

FR33

TH02

Eagle

Phoenix

Ring: None

Line: 1

Wait GPI: None

Wait GPO: None

On Air GPI: GPI06

On Air GPO: GPO06

Edit

OK

Cancel

2

**Key Configuration** Edit Label

Codec

Device

FR33

TH02

Eagle

Phoenix

Ring: GPI04

Line: 2

Wait GPI: GPI07

Wait GPO: GPO07

On Air GPI: None

On Air GPO: None

Edit

OK

Cancel

3



For **Phoenix Studio, Stratos, Venus, Venus V2, Venus V3 or Venus V4** audiocodec, the available configuration options are:



- **"Ring"**: allows you to select the physical or virtual GPI where the incoming call signal provided by the codec is wired or addressed. The key starts to blink when there is an incoming call. This function can be combined in the same key with any of the following four functions.
- **"Call GPO"**: selects and configures the physical or virtual GPO output associated with "CALL" function. The key turns on when activated and makes the call from the corresponding channel.
- **"On Air GPO"**: selects and configures the physical or virtual GPO output associated with "ON AIR" function. The key turns on when activated and puts the call on the air (ON AIR mode).
- **"Line"**: for dual line codecs (all of them except Phoenix Mercury), this identifies the integrated line 1 and line 2, to assign the different GPIs and GPOs for remote control.
- **"OK"**: allows you to accept the created or edited configuration.
- **"Cancel"**: allows you to reject the created or edited configuration. No change you may have made is saved.

**IMPORTANT NOTE:** The functions "Call GPO" and "On Air GPO" are exclusive between them (a programmable key can have only one of the two functions associated). In addition, when a GPO already used is selected, a warning message will appear.

#### 4.3.2.5. Configuration of "Multiplex" programmable keys.

Programmable keys that are set to "Multiplex" enables you to make a quick management of signal routing toward an "MPX" type internal summing bus (these buses are typically used for sending to codecs, hybrids or other auxiliary destinations). A key set to this function is assigned with a dedicated icon.

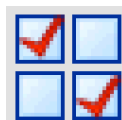

The lower part of the "Programmable Keys" submenu will show the associated options for "Multiplex" type keys, when this configuration mode is selected. In order to be able to configure the programmable key (or edit a previously created configuration), you have to press the **"Edit"** button, to active and allows you to assign to that key one of the 10 available "MPX" buses:

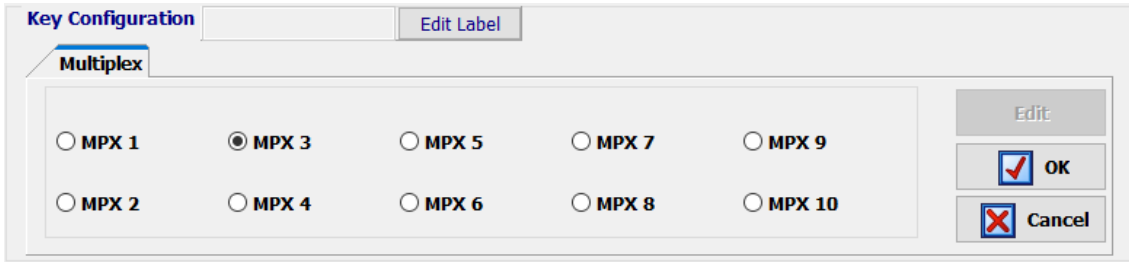

These keys work as follows: when you press and keep pressed the key you can activate the routing toward the associated "MPX" bus of any audio input channel assigned to a fader at that moment. To activate that routing, you just have to press the "**SELECT**" key of the desired channel/s (the associated LED turns on) while programmable key is pressed; by pressing again the "SELECT" key that routing is deactivated (the associated LED turns off). When you stop pressing the programmable key, the activated "SELECT" keys turns off and they recover its original function.

**NOTE:** This type of keys is usually associated with the operation of the "MPX" buses in "Multiplex" mode, although they can also be used with buses configured in "Clean Feed" mode. See section 4.2.2.1 of this manual.

**IMPORTANT NOTE:** For firmware versions 1.73 of CPU and 1.31 of DSP Router or higher, the routing toward MPX internal summing buses is saved on console configuration and it will appear in the "Routing Configuration" submenu when the active configuration is read.

#### 4.3.2.6. Configuration of "Cue Reset" programmable key.

"Cue Reset" option allows you to configure a programmable key as a key to disconnect immediately all the signal sendings to the CUE bus at that moment. A key set to this function is assigned with a dedicated icon.



The lower part of the "Programmable Keys" submenu will show no options when this configuration mode is selected.

The activation of this "Cue Reset" function will have the following result in AEQ FORUM control surface: when the key is pressed, all the circuits or channels being sent to the CUE bus of the mixer will be disconnected and the LEDs of all the "CUE" keys that may be active will be turned off.

In the case of **FORUM IP** and **FORUM IP SPLIT**, there is a specific key in the **control room monitoring section** that execute that function (although it's also possible to associate it simultaneously to a programmable key).

#### 4.3.2.7. Configuration of "Orders" programmable keys.

Programmable keys that are set to "Orders" enables you to send the orders microphone to the selected output channel (Talkback functionality). A key set to this function is assigned with a dedicated icon.



The lower part of the "Programmable Keys" submenu will allow you to configure the output associated with the programmable key. In order to be able to configure the programmable key (or edit a previously configured key), you have to press the "Edit" button, to active and allows you to assign to that key any of the outputs defined in the system.

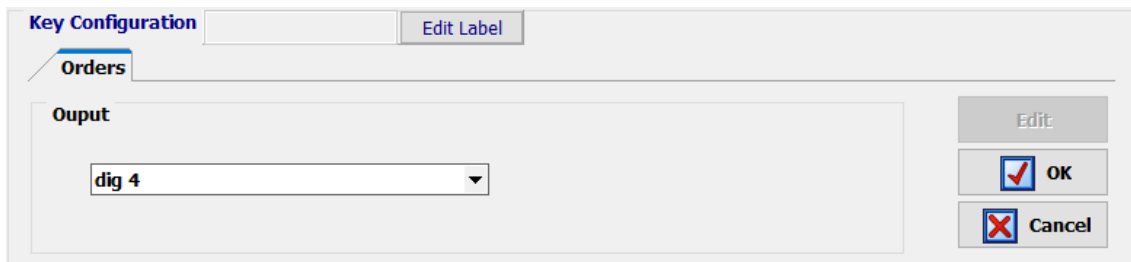

These keys work as follows: when you press and keep pressed the key you send to the selected output the orders microphone (any routing previously defined for that output is deactivated). When you stop pressing the programmable key, you stop sending the orders microphone and the previous routing is recovered.

#### 4.3.2.8. Configuration of "Memory" programmable keys.

Programmable keys that are set to "Memory" allows you to load the selected configuration memory or snapshot. A key set to this function is assigned with a dedicated icon.



The lower part of the "Programmable Keys" submenu will allow you to configure the memory or snapshot associated with the programmable key. In order to be able to configure the key (or edit a previously configured key), you have to press the "Edit" button, to active and allows you to assign to that key any of the memories defined in the system.

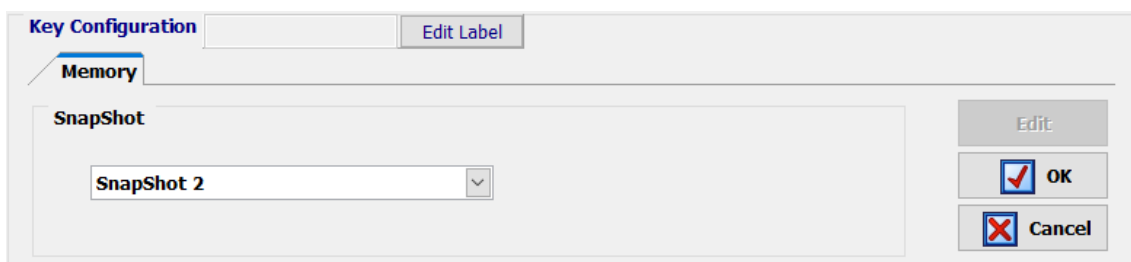

**IMPORTANT NOTE 1:** When you press the key, the configuration stored in the selected memory is directly loaded into the console. In this case no confirmation is requested (it will be required only when the memory is loaded from the "MEMORY" menu: see section 3.3 of this manual). Logically, a certain user will only be able to load the snapshots assigned to that user (or to all users) and the first snapshot (always available): see section 4.3.5 of this manual.

**IMPORTANT NOTE 2:** For firmware versions 1.73 of CPU and 1.31 of DSP Router or higher, when a new configuration memory or snapshot is loaded, the audio of the activated channel or channels (ON AIR) will not be interrupted (and the associated routing will remain) provided that in the new memory the activated channels are placed in the same fader positions. The routing toward MPX internal summing buses of any signal will also remain (whether the signal is ON AIR or not).

#### 4.3.2.9. Configuration of "Studio Monitor Attenuation" programmable keys.

Programmable keys that are set to "Studio Monitor Attenuation" allows you to replace the studio monitors muting when a studio microphone is activated (or any other channel with "Studio On Air" option activated: see section 4.2.3.1 of this manual) with a programmable attenuation (-10dB, -15dB or -20dB) of those monitors level. A key set to this function is assigned with a dedicated icon.

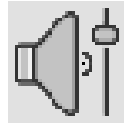

The lower part of the "Programmable Keys" submenu will allow you to configure the attenuation associated with the programmable key. In order to be able to configure the programmable key (or edit a previously configured key), you have to press the "Edit" button, to active and allows you to assign to that key any of the 3 available attenuations: -10dB, -15dB and -20dB.

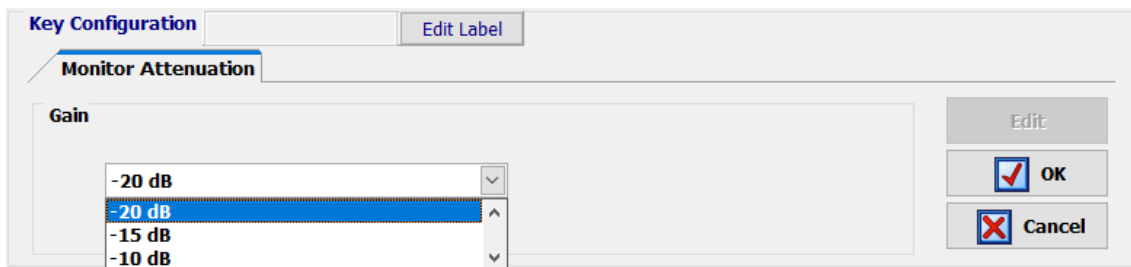

These keys work as follows: when the "Studio Monitor Attenuation" key is not pressed, the studio monitors are muted when a studio microphone is activated.

When you press the key, it turns on and the studio monitors are attenuated when a microphone is activated according to the previous programming (-10dB, -15dB or -20dB). When you press the key again, it turns off and the studio monitors returns to initial operation.

When there are several "Studio Monitor Attenuation" keys defined, the operation is exclusive, it's not possible to turn on more than one key simultaneously (the activation of one of them entails the deactivation of the one active at that moment and the corresponding modification of the attenuation).

#### 4.3.2.10. Configuration of "Auto Cue" programmable key.

"Auto Cue" option allows you to configure a programmable key to modify the working mode of the signals sending to the CUE bus and the control monitoring. A key set to this function is assigned with a dedicated icon.

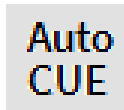

When you press the key, it turns on and, if there is one or more signals sent to CUE, they are deactivated. In addition, the CUE keys become exclusive, it's not possible to turn on more than one key simultaneously (the activation of one of them entails the deactivation of the one active at that moment). Finally, when a signal is sent to CUE, in control monitoring section the signal selected at that moment ("PROG", "AUD", "SEL" or "CUE") is no longer monitored and the last activated CUE is then monitored. When that CUE sending is deactivated, the previously selected signal is monitored again.

When this function is deactivated by pressing again the "Auto Cue" key, it turns off and, if there is a signal sent to CUE, it is deactivated. In addition, the CUE keys stop working exclusively and control monitoring returns to its normal working mode.

#### 4.3.2.11. Configuration of "A/B Mode" programmable key.

"A/B Mode" option allows you to configure a programmable key to activate the A/B working mode. A key set to this function is assigned with a dedicated icon.

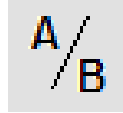

This key works as follows: when you press and keep pressed the key, it turns on and activated the A/B working mode in order to be able to accomplish a fast change of the input assigned to one or more channels. To activate that change, you just have to press the "SELECT" key of the desired channel (the associated LED turns on for a while) while programmable key is pressed in order to load the input defined as B in the snapshot for that channel and show it in the channel display. By pressing again, the "SELECT" key you can assign again signal A to the channel. If you press the "SELECT" key of a channel with no signal B defined, logically no change occurs. When you stop pressing the "A/B" programmable key, it turns off and the "SELECT" keys recover its original function.

This key allows you to configure any other operating mode of the channel activation keys (see section 4.3.5 of this manual) and momentarily switch to A/B mode without needing to load another configuration memory or snapshot.

#### 4.3.2.12. Configuration of "To Mixer Bus" programmable keys.

Programmable keys that are set to "To Mixer Bus" enables you to make a quick management of signal routing toward an "Internal" type summing bus. A key set to this function is assigned with a dedicated icon.



The lower part of the "Programmable Keys" submenu will allow you to configure the summing bus associated with the programmable key. In order to be able to configure the programmable key (or edit a previously configured key), you have to press the "Edit" button, to active and allows you to assign to that key any of the summing buses (of "Internal" type) defined in the system.

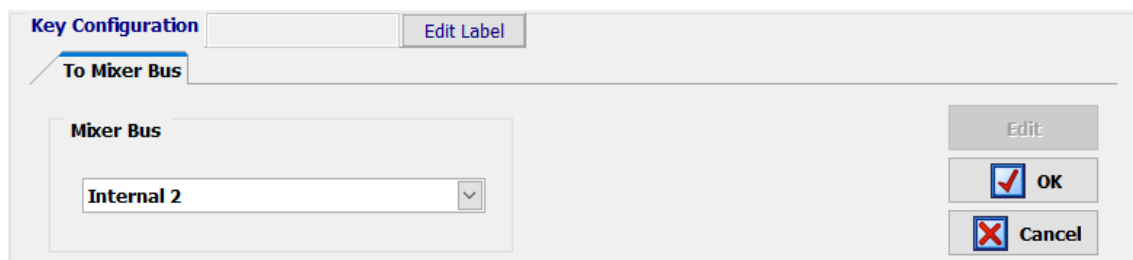

These keys work as follows: when you press and keep pressed the key you can activate the routing toward the associated summing bus of any audio input channel assigned to a fader at that moment. To activate that routing, you just have to press the "SELECT" key of the desired channel/s (the associated LED turns on) while programmable key is pressed; by pressing again the "SELECT" key that routing is deactivated (the associated LED turns off). When you stop pressing the programmable key, the activated "SELECT" keys turns off and they recover its original function.

#### 4.3.2.13. Configuration of "Split CUE" programmable keys.

Programmable keys that are set to "Split CUE" enables you to activate/deactivate the sending of the CUE bus to one of the channels of the control monitoring. A key set to this function is assigned with a dedicated icon.

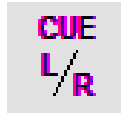

The lower part of the "Programmable Keys" submenu will allow you to select the channel of the control monitoring (left or right) you want to send the CUE bus to. In order to be able to configure the programmable key (or edit a previously configured key), you have to press the "Edit" button, to active and allows you to select the left or right channel.

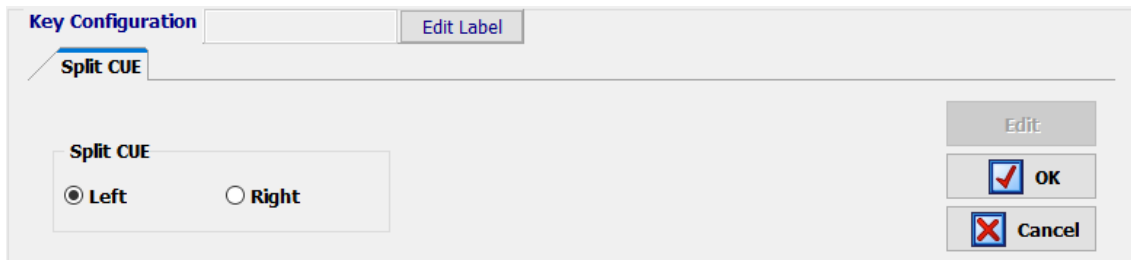

These keys work as follows: when the "Split CUE" key is not pressed, on the control speakers and headphones you will hear the signal selected in the control room monitoring section.

When you press the key, it turns on and then in the control speakers and headphones you will hear on the channel configured in the key (left or right) the signal present on the CUE bus, while on the other channel (right or left) you will hear the signal selected in the control room monitoring section. When you press the key again, it turns off and the control speakers and headphones return to initial operation.

When there are several "Split CUE" keys defined, the operation is exclusive, it's not possible to turn on more than one key simultaneously (the activation of one of them entail the deactivation of the one active at that moment). This type of keys also works exclusive with the "Remote Production" type keys.

#### 4.3.2.14. Configuration of "Remote Production" programmable keys.

Programmable keys that are set to "Remote Production" enables you to dynamically configure the signal to be used as orders/autocontrol microphone, as well as an audio output for remote monitoring. A key set to this function is assigned with a dedicated icon.



The lower part of the "Programmable Keys" submenu will show the associated options for "Remote Production" type keys, when this configuration mode is selected:

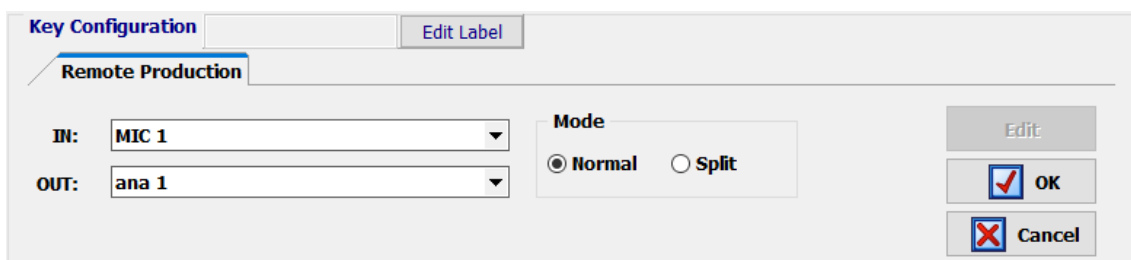

In order to be able to configure the programmable key (or edit a previously created configuration), you have to press the **"Edit"** button, to active and allows you to configure the following fields:

- **"IN"**: allows you to select the mono or stereo input channel that will be used as orders/autocontrol microphone. When the selected signal is stereo, only the L channel will be used for orders.
- **"OUT"**: allows you to select the mono or stereo output channel that will be used for remote monitoring.
- **"Mode"**: allows you to select the working mode: "Normal" or "Split". This field is only available when the channel selected in "OUT" is stereo; if that channel is mono, the mode is automatically configured as "Normal" and cannot be changed.

These keys work as follows: when the "Remote Production" key is not pressed, the operation of the control monitors and headphones and the CUE output is the usual one.

When you press the key, it starts blinking and the physical outputs of control monitors and headphones and CUE are muted. At the same time, the orders/autocontrol microphone is replaced by the input selected in **"IN"**. Additionally, the monitoring is sent to the output selected in **"OUT"** as follows:

- When **"OUT"** channel is **mono** and **"Mode"** is **"Normal"**, we'll have MON CONTROL L + MON CONTROL R + CUE L + CUE R at that output.
- When **"OUT"** channel is **stereo** and **"Mode"** is **"Normal"**, we'll have MON CONTROL L + CUE L at the L channel of that output and MON CONTROL R + CUE R at the R channel.
- When **"OUT"** channel is **stereo** and **"Mode"** is **"Split"**, we'll have MON CONTROL L + MON CONTROL R + CUE L + CUE R at the L channel of that output and MON STUDIO L + MON STUDIO R at the R channel.

In the first two cases, the control of the send level towards the "OUT" output is accomplished by means of the control of the **monitors level** of the **Control section** ("MONITOR" fader in the "Forum Virtual" application or "MONITOR" encoder in the physical surface). Furthermore, the control of the **CUE level** of that section ("CUE" fader in the "Forum Virtual" application or "CUE" encoder in the physical surface) allows to set the contribution to the sum of the signal present on the CUE bus.

This is also valid in the third case (**"Split"** mode) to control the send level to the **L channel** of the "OUT" output. On the other hand, the control of the send level towards the **R channel** of that output (where we'll have MON STUDIO L + MON STUDIO R) is accomplished by means of the control of the **headphones level** of the **Control section** ("HP" fader in the "Forum Virtual" application or "HP/SEL" encoder in the physical surface), while the signal present will be the one selected by means of the keys of the **Studio section**. In this case, when you press the "Remote Production" key, the physical outputs of studio monitors and headphones are NOT muted and the monitors and headphones level controls of the **Studio section** keep on allowing you to control the level of those outputs.

When you press the "Remote Production" key again, it turns off and both the orders/autocontrol microphone and the monitoring returns to initial operation.

When there are several "Remote Production" keys defined, the operation is exclusive, it's not possible to activate more than one key simultaneously (the activation of one of them entail the deactivation of the one active at that moment). This type of keys also works exclusive with the "Split CUE" type keys.

**IMPORTANT NOTE:** The "Remote Production" option has been designed so that remote monitoring is accomplished by means of **headset**, so that, if the orders/autocontrol microphone is set ON AIR, the audio will not be interrupted.

### 4.3.3. "Mic Group Configuration" submenu.

"Mic Group Configuration" submenu is accessed, from the drop-down menu "Programmable Configuration", by clicking on the icon:



"Mic Group Configuration" submenu allows you to define groups of microphones. Within this submenu there are two distinct areas on the screen:

- The left side shows the list of groups of microphones set up.
- The right side shows the list of the microphone inputs that are part of the group selected at that moment in the left part of the screen.

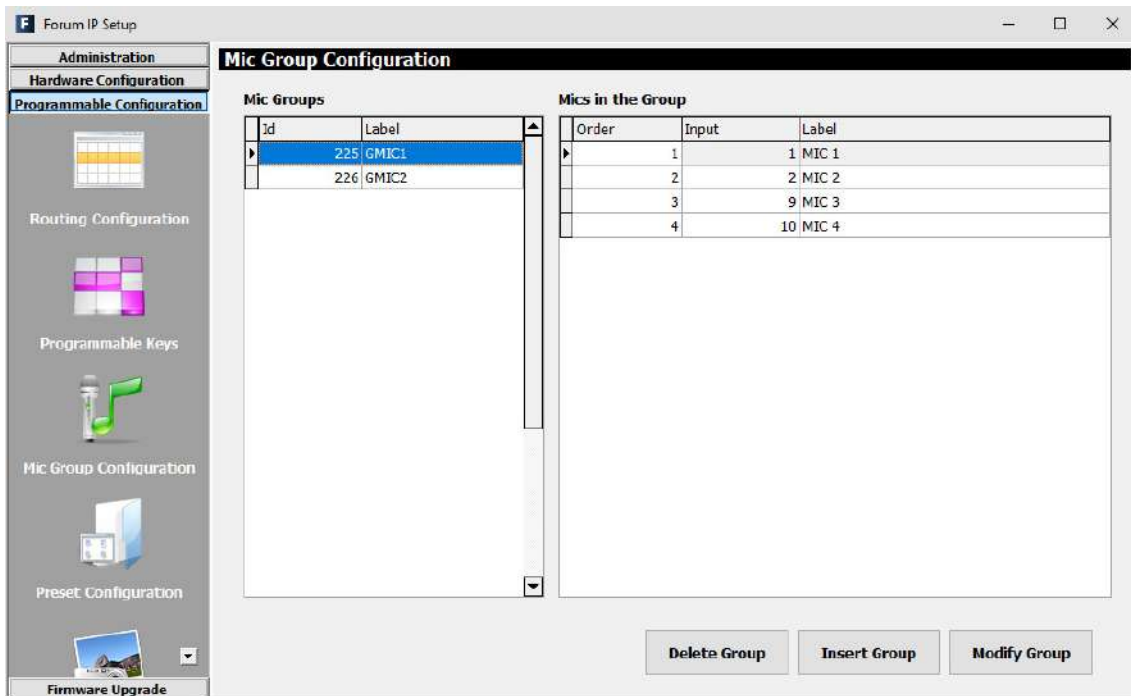



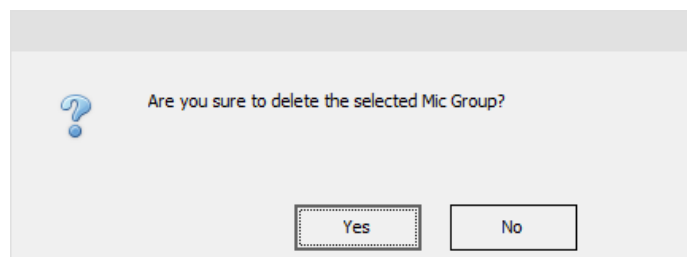

The three buttons at the bottom of the screen allow you to manage the list of groups of microphones and their individual configuration.

- **"Delete Group"**: deletes the selected group of microphones. Confirmation is requested.



- **"Insert Group"**: creates a new group of microphones and allows you to insert and set up the signals through the following menu options:

- **"Label"**: name or ID for the group of microphones. A maximum of 6 characters is recommended.
-  adds ALL microphones or audio inputs from the "Inputs available" column to the "Inputs in the Group" column.
-  adds ONLY the microphone or audio input selected from the "Inputs available" column to the "Inputs in the Group" column.
-  removes ONLY the microphone or audio input selected from the "Inputs in the Group" column back to the "Inputs available" column.
-  removes ALL the microphones or audio inputs from the "Inputs in the Group" column back to the "Inputs available" column.
- **"OK"**: allows you to accept the created or edited configuration.
- **"Cancel"**: allows you to reject the created or edited configuration. No change you may have made is saved.

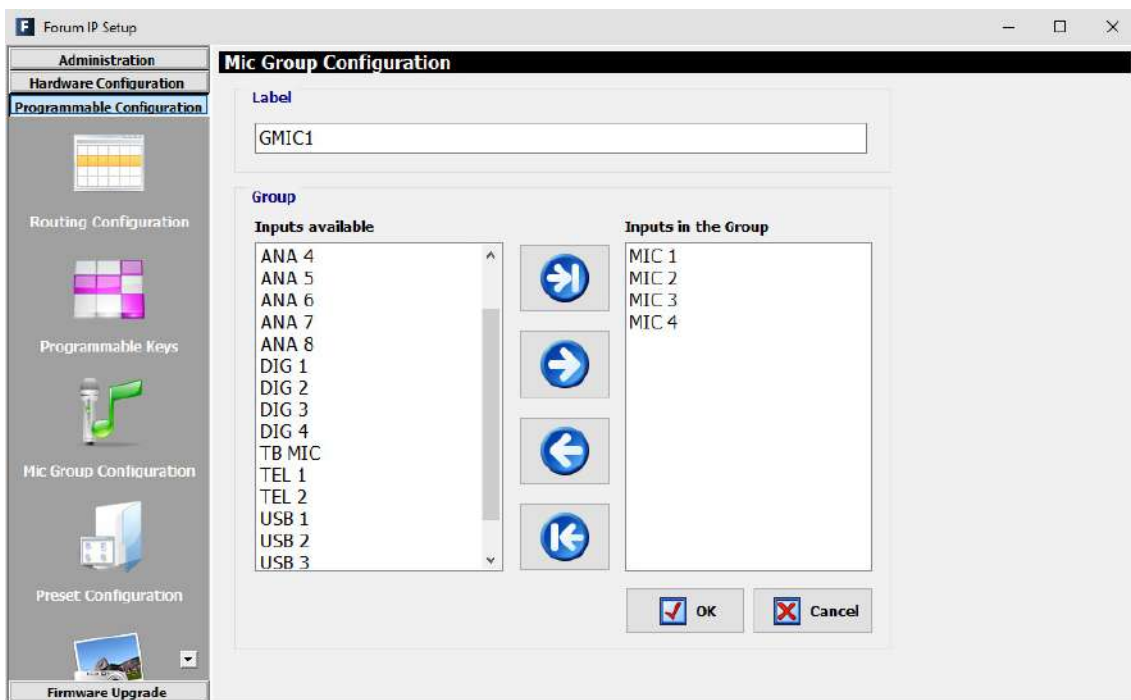

- **"Modify Group"**: allows you to modify the selected and previously created group of microphones. The menu is identical to previously described for "Insert Group" option.

#### 4.3.4. "Preset Configuration" submenu.

"Preset Configuration" submenu is accessed, from the drop-down menu "Programmable Configuration", by clicking on the icon:







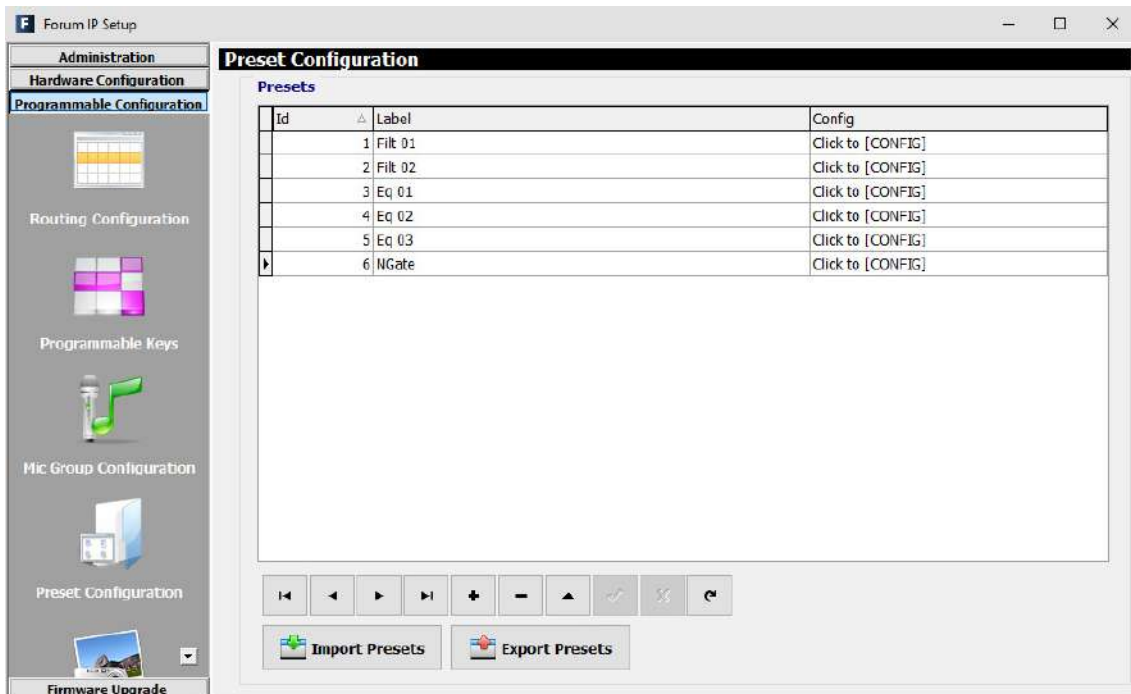





"Preset Configuration" submenu allows you to create default settings associated with the different audio processes available in AEQ FORUM: equalizers, filters, compressors/limiters and noise gates.

The main screen of this submenu is presented as a list of all the presets created ordered by their "Id" and with a "Label" or name as identifier.



The lower part of the "Preset Configuration" submenu includes a set of standardized buttons to manage the list of presets:

	Allows you to scroll to the top of the list.
	Allows you to move to the position immediately above in the list.
	Allows you to move to the position immediately below in the list.
	Allows you to scroll to the last position of the list.
	Allows you to insert a new entry in the list.
	Allows you to delete the selected entry from the list. Confirmation is requested.
	Allows you to edit the selected entry.
	Allows you to accept changes to the selected entry.
	Allows you to reject to the selected entry.
	Allows you to refresh the information shown in the list.

The main screen of this submenu has also two buttons at the bottom:

- **"Import Presets"**: allows you to import to "Forum IP Setup" application all presets stored on an AEQ FORUM IP mixing console that is connected through IP to the computer where the application is installed.
- **"Export Presets"**: allows you to export from "Forum IP Setup" application all stored presets to an AEQ FORUM IP mixing console that is connected through IP to the computer where the application is installed.

The advanced configuration menu of each one of the stored presets is accessed by clicking **"Click to [CONFIG]"** and then clicking again on the **"Config"** button that will appear. The screen you access to looks as follows:

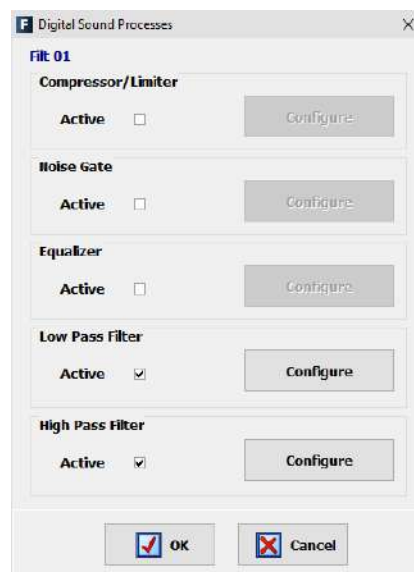

#### 4.3.4.1. Advanced configuration of Compressor/Limiter.

From the initial screen of the presets advanced information menu ("Digital Sound Processes") you can configure and activate/deactivate the Compressor/Limiter operation.

When you select the "Active" checkbox, the "**Configure**" button gets active and gives you access to the graphic display where the Compressor/Limiter associated parameters can be modified.

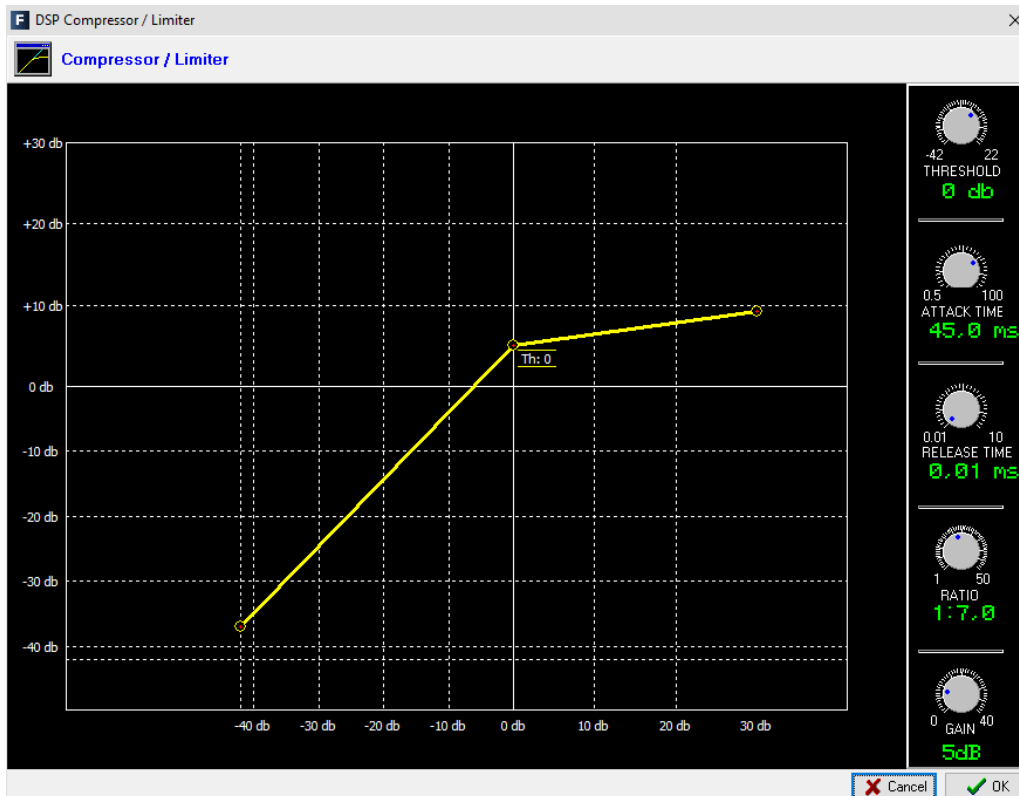

Dynamics processors are used to modify the dynamic ranges of an audio signal to adapt it to specific needs or to produce certain sound effects. A compressor enables you to reduce the dynamic range of the signal. Your purpose may be to adapt a signal with a very broad dynamic range to a circuit that will not support such wide variations in level, or to generate a certain sound in a signal.

The graph represents the variation produced in the different levels of the signal applied to this function. On the horizontal axis are the input levels, while the vertical axis shows output levels.

The "Compressor/Limiter" function acts as a "constant gain" compressor; that is, below the threshold, all input signals are amplified (or not amplified) equally, while above the threshold, the input levels are reduced to a greater or lesser degree according to the compression ratio.

If the compression range selected is the maximum, the function will act as a limiter in such a way that the signals that exceed the selected threshold at input will not exceed a certain level at output. For example, with a threshold = 0 dB, a gain of 10 dB and a compression ratio of 1:50, you will ensure that all the signals that exceed 10 dB at input will also be output at 10 dB, while the signals that are below the threshold will have an overall gain of 10 dB.

The available controls are:

- "THRESHOLD": this is the threshold above which the compressor will act. Signal levels that exceed this threshold will be affected by the compressor settings. The threshold range varies from -42dB to +22dB.

- "ATTACK TIME": this is the time it takes the compressor to react to an increase in the input signal. It ranges between 0.5 and 100 ms.
- "RELEASE TIME": this is the maintenance time during which the compressor keeps acting, even when the level of the input signal has fallen below the threshold. It ranges between 0.01 and 10 s.
- "RATIO": this is the compression ratio. A ratio of 1:1 does not involve any variation in the signal, as the level of the input signal is maintained at the output. A ratio of 2:1 indicates that the level of an input signal which exceeds the threshold will be reduced to half at the output. The highest ratio available is 50:1, which will be used to implement signal limiters. The limiter must reduce all signals exceeding a certain level to that level.
- "GAIN": this enables you to apply a general gain to the signal. This entails a general increase of the signal level, which will be especially noted at low input levels that are under the threshold set. It ranges between 0 and 40dB.
- "OK": allows you to accept the created or edited configuration. A double confirmation is required.
- "Cancel": allows you to reject the created or edited configuration. No change you may have made is saved.

#### 4.3.4.2. Advanced configuration of Noise Gate.

From the initial screen of the presets advanced information menu ("Digital Sound Processes") you can configure and activate/deactivate the Noise Gate operation.

When you select the "Active" checkbox, the "Configure" button gets active and gives you access to the graphic display where the Noise Gate associated parameters can be modified.

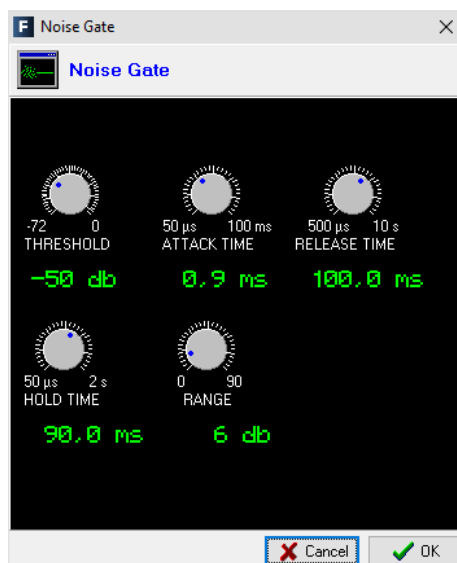

A noise gate is a dynamics processor that lets signals through whose level exceeds a certain threshold, strongly attenuating the signal levels below that threshold and thus muting noise. It enables its user to eliminate extraneous noise from a signal source, whether it is background noise in the studio, in the case of a microphone, or the background noise generated by a playback device, for example, a tape.

The available controls are:

- "THRESHOLD": determines the level above which signal is allowed through the gate.
- "ATTACK TIME": the time for the gate to react to a signal that is exceeding the threshold.
- "RELEASE TIME": the time that the gate should remain open once the signal exceeding threshold has disappeared.

- "HOLD TIME": the time that the gate should remain open when the signal falls below the threshold.
- "RANGE": the limit of dynamic range where created configuration will have effect.

The threshold must be adjusted to a level slightly higher than the level of the noise to be avoided. Thus, the threshold will be set at a very low level. Above the threshold, the noise gate does not act (unity gain), letting the rest of the signal through without processing it. The gate remains closed; i.e. when the signal surpasses the threshold level, the gate opens. The attack time is the time the gate takes to open (unity gain) when it receives a signal whose amplitude exceeds the threshold level; this time must be short to avoid cutting off the beginning of a sentence or song. The release time is the time the gate takes to close when the signal level falls below the threshold. The hold time is the minimum time during which the gate remains open; it is used to prevent the gate from closing when the signal level drops briefly—for example, when an announcer pauses while speaking. The hold time prevents the gate from opening and closing constantly in the presence of a signal whose level fluctuates in a range close to the threshold level.

#### 4.3.4.3. Advanced configuration of Equalizer.

From the initial screen of the presets advanced information menu ("Digital Sound Processes") you can configure and activate/deactivate the Equalizer operation.

When you select the "Active" checkbox, the "**Configure**" button gets active and gives you access to the graphic display where the Equalizer associated parameters can be modified.

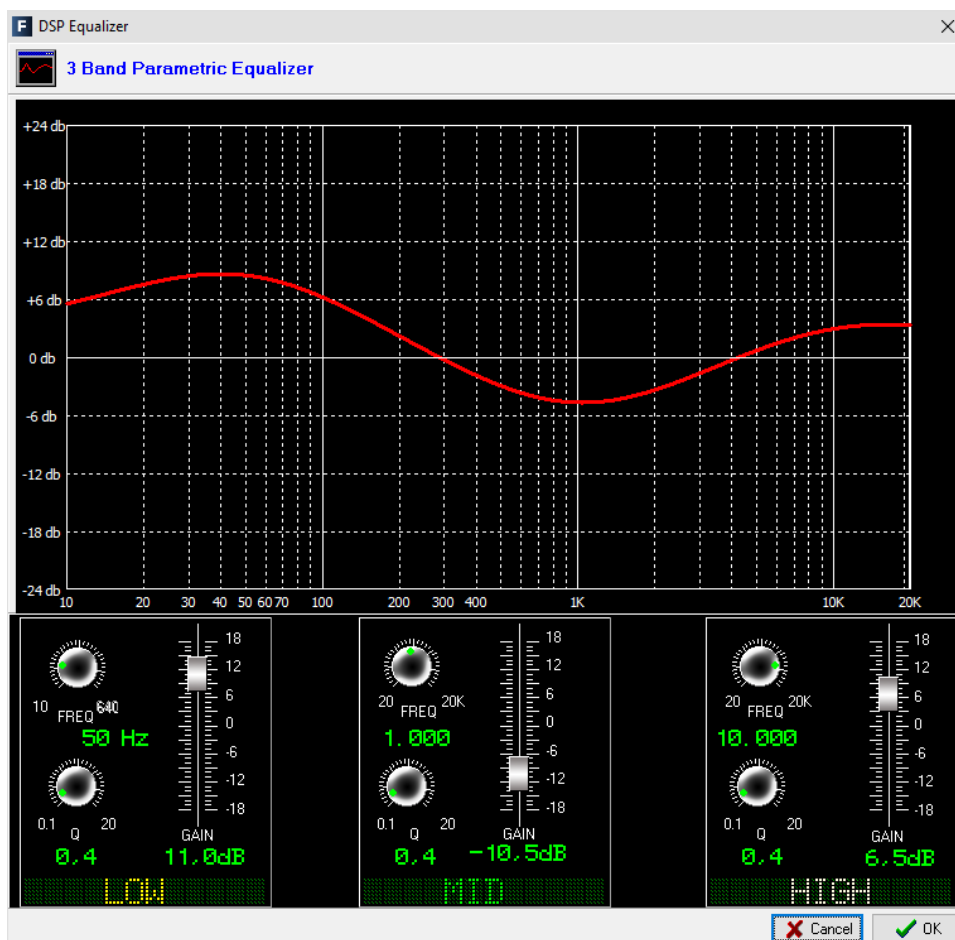

#### 4.3.4.4. Advanced configuration of Low Pass Filter.

From the initial screen of the presets advanced information menu ("Digital Sound Processes") you can configure and activate/deactivate the Low Pass Filter operation.

When you select the "Active" checkbox, the "**Configure**" button gets active and gives you access to the graphic display where the Low Pass Filter associated parameters can be modified.

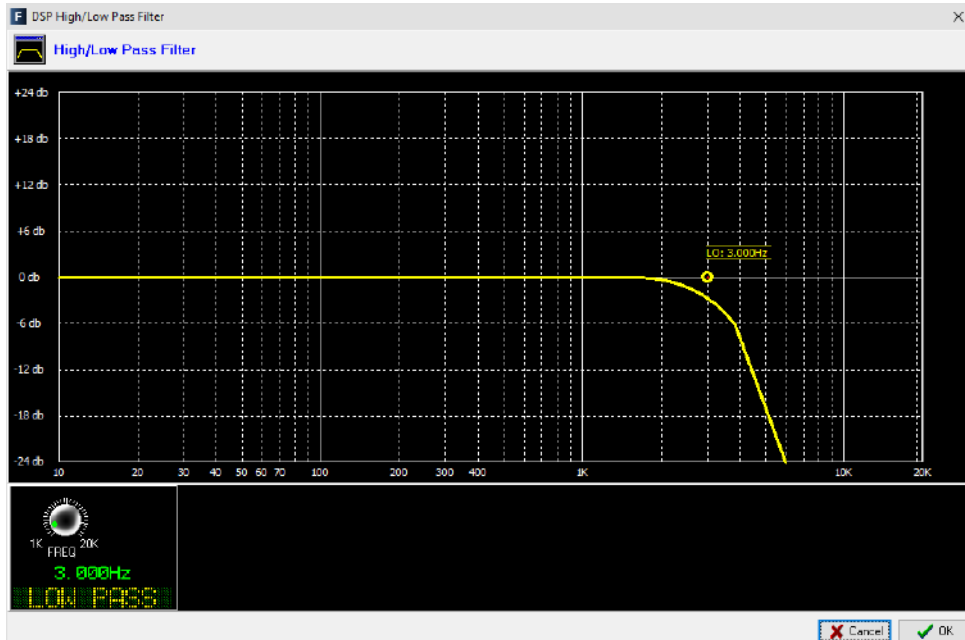

#### 4.3.4.5. Advanced configuration of High Pass Filter.

From the initial screen of the presets advanced information menu ("Digital Sound Processes") you can configure and activate/deactivate the High Pass Filter operation.

When you select the "Active" checkbox, the "**Configure**" button gets active and gives you access to the graphic display where the High Pass Filter associated parameters can be modified.

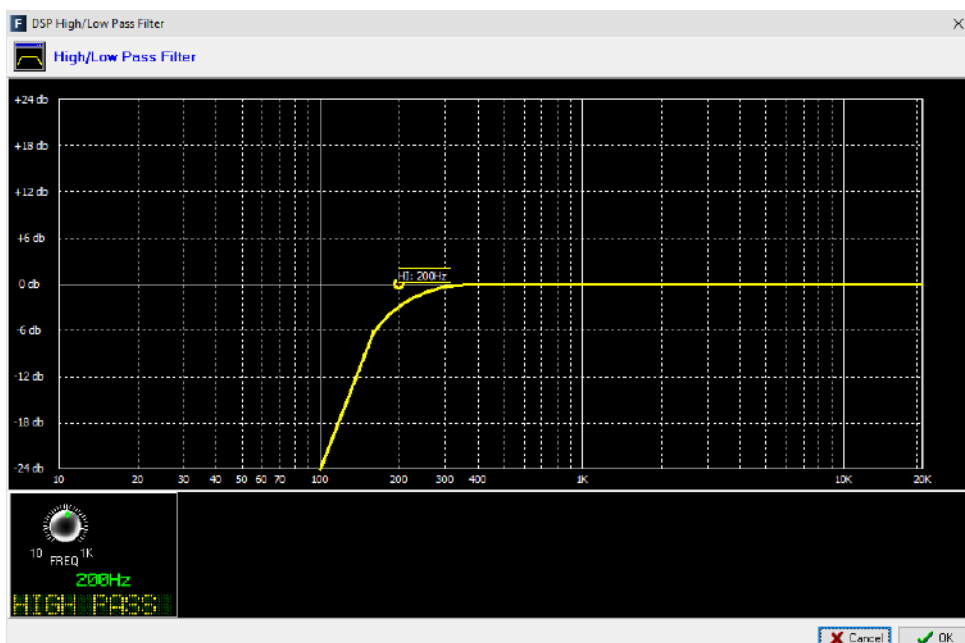

### 4.3.5. "SnapShot Configuration" submenu.

"SnapShot Configuration" submenu is accessed, from the drop-down menu "Programmable Configuration", by clicking on the icon:



"SnapShot Configuration" submenu allows you to manage the different configurations memories stored in AEQ FORUM and available to operators through the internal menu of the main screen of the Control and Monitoring section of the unit (please refer to section 3.3 of this manual).

You can also load the configuration memories into the console by means of "Memory" type programmable keys (please refer to section 4.3.2.8 of this manual).

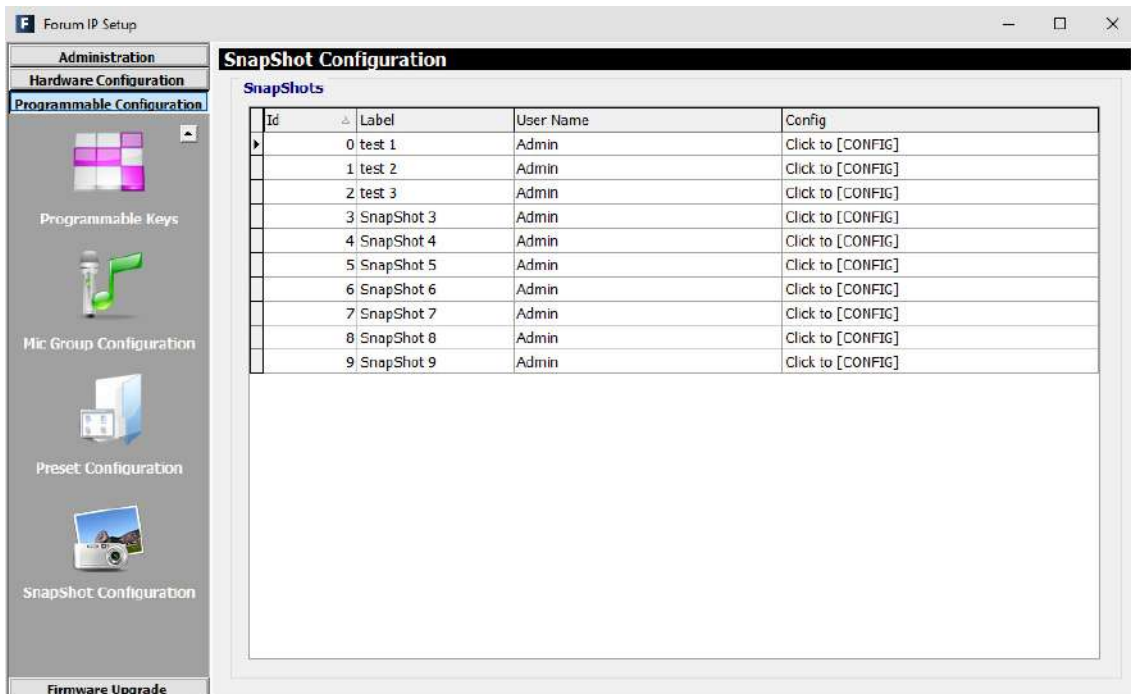

The main screen of this submenu is presented as a list of all the snapshots stored (there are up to 10 available snapshots), ordered by their "Id" and with a "Label" or name as identifier.

The "User Name" column allows you to assign each of the snapshots to a specific console user. The "<ALL>" option allows that any of the defined users can access to that snapshot. The first snapshot in the list, with "Id" 0, will also always be available to any user (even if the "LOGOU" key has been pressed and no user is loaded).

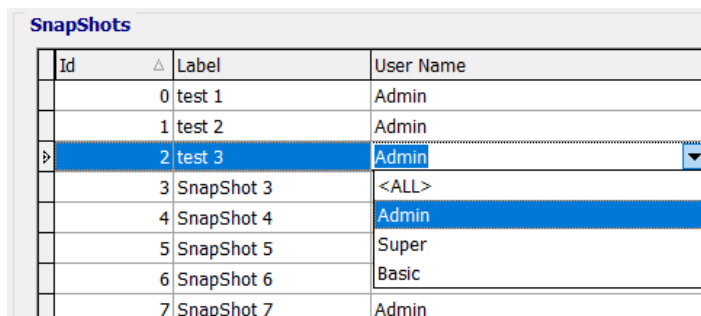

The advanced configuration menu of each one of the snapshots is accessed by clicking "**Click to [CONFIG]**" and then clicking again on the "**Config**" button that will appear. The screen you access to looks as follows:

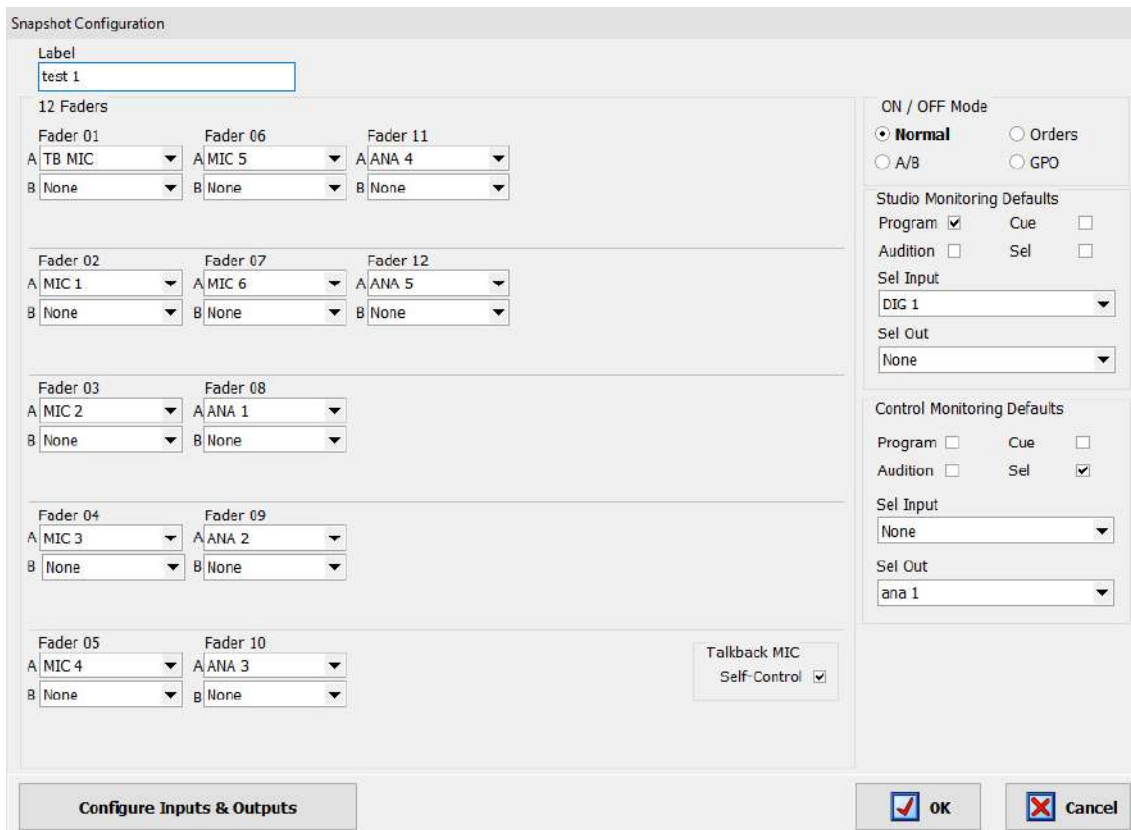

The available options in the snapshots advanced configuration menu, described from left to right and top to bottom, are:

- "**Label**": alphanumeric label for the snapshot memory.
- "**Faders**": a series of drop-down menus allow you to assign an input audio channel to each one of the physical faders of the control surface (up to 12 for FORUM, up to 20 for GRAND FORUM and up to 24 for SPLIT). The faders are numbered, from top to bottom and from left to right, 1 through the number previously defined in "Board Configuration" submenu (see section 4.2.1). The number of faders to configure is defined by the number of 4 faders modules (FRCH) installed on the FORUM control surface (1, 2 or 3 FRCH modules can be installed, providing then with a maximum of 4, 8 or 12 channels), GRAND FORUM (4 or 5 FRCH modules can be installed, providing then with a maximum of 16 or 20 channels) or SPLIT (up to 6 FRCH modules can be installed, providing then with a maximum of 24 channels).

It's also possible to associate a **channel B** to each fader: if you press the channel activation lower key for more than 500 ms and then release it, a change of the assigned input will be accomplished, as long as mode "A/B" is activated in the snapshot (see next page) or if you press the "SELECT" key, when other mode is active and "A/B" mode is activated by means of a programmable key (see section 4.3.2.11 of this manual).

- "**Talkback MIC**": allows you to configure the operation of the microphone input present in the common I/O's section at the rear panel of the AEQ FORUM. When "**Self-Control**" checkbox is **not** activated, that input is configured only as an orders microphone toward studio or return for any open communication lines (this is a typical configuration for AEQ FORUM when installed in a Studio/Control configuration). When "**Self-Control**" checkbox is activated, that input is configured as autocontrol microphone (it simultaneously works as orders microphone), so the host of the radio program is also the operator of the mixing console (this is a typical configuration when the Studio and

Control areas of the radio station are in the same room). Only when "Self-Control" checkbox is activated you can assign the talkback mic to a fader (when it's not activated, the mic will not appear in the channels list).

**NOTE:** There is a type of programmable key ("**Remote Production**") that allows you to dynamically configure the signal to be used as orders/autocontrol microphone (see section 4.3.2.14 of this manual).

- "**ON / OFF Mode**": section where you can configure the working mode of the **channel activation keys**. There are 4 options:

ON / OFF Mode

**Normal**       Orders

A/B             GPO

- "**Normal**": the upper red key is associated with **ON** function and the lower yellow key is associated with **OFF** function. The operation is exclusive, both keys can not be turned on simultaneously.
- "**Orders**": when you press and keep pressed the **lower** key you send the orders microphone to the output channel associated with the input present at the channel (Talkback functionality). The **upper** key is associated with **ON/OFF** function (allows you to activate/deactivate the channel).

When this option is selected a new field ("**Orders**") associated with each one of the faders is shown and allows to assign that output channel (it can also be defined in the advanced configuration menu of the input channel: see section 4.2.3.1 of this manual).

Snapshot Configuration

Label  
test 1

12 Faders

<b>Fader 01</b> A TB MIC B None None Orders	<b>Fader 06</b> A MIC 5 B None ana 3 Orders	<b>Fader 11</b> A ANA 4 B None None Orders
<b>Fader 02</b> A MIC 1 B None dig 1 Orders	<b>Fader 07</b> A MIC 6 B None ana 4 Orders	<b>Fader 12</b> A ANA 5 B None None Orders
<b>Fader 03</b> A MIC 2 B None dig 2 Orders	<b>Fader 08</b> A ANA 1 B None None Orders	
<b>Fader 04</b> A MIC 3 B None None Orders	<b>Fader 09</b> A ANA 2 B None None Orders	
<b>Fader 05</b> A MIC 4 B None None Orders	<b>Fader 10</b> A ANA 3 B None None Orders	

- "**A/B**": if you press the **lower** key for more than 500 ms, when you release it a fast change of the input assigned to the channel is accomplished (the new input will be shown in the channel display). The **upper** key is associated with **ON/OFF** function (allows you to activate/deactivate the channel).

When this option is selected the input selected in drop-down menu "B" is the one you'll change to by that long press.

You can also activate this working mode by means of a programmable key: in that case the signal change will be accomplished by pressing the "SELECT" key while programmable key remains pressed (see section 4.3.2.11 of this manual).

Snapshot Configuration

Label  
test 1

12 Faders

<p>Fader 01</p> <p>A TB MIC ▼</p> <p>B None ▼</p>	<p>Fader 06</p> <p>A MIC 5 ▼</p> <p>B None ▼</p>	<p>Fader 11</p> <p>A ANA 4 ▼</p> <p>B None ▼</p>
<p>Fader 02</p> <p>A MIC 1 ▼</p> <p>B DIG 1 ▼</p>	<p>Fader 07</p> <p>A MIC 6 ▼</p> <p>B None ▼</p>	<p>Fader 12</p> <p>A ANA 5 ▼</p> <p>B None ▼</p>
<p>Fader 03</p> <p>A MIC 2 ▼</p> <p>B DIG 2 ▼</p>	<p>Fader 08</p> <p>A ANA 1 ▼</p> <p>B None ▼</p>	
<p>Fader 04</p> <p>A MIC 3 ▼</p> <p>B DIG 3 ▼</p>	<p>Fader 09</p> <p>A ANA 2 ▼</p> <p>B None ▼</p>	
<p>Fader 05</p> <p>A MIC 4 ▼</p> <p>B DIG 4 ▼</p>	<p>Fader 10</p> <p>A ANA 3 ▼</p> <p>B None ▼</p>	

- "GPO": when you press and keep pressed the **lower** key you activate the physical or virtual GPO output associated with the input present at the channel (the GPO is deactivated when you release the key). The **upper** key is associated with **ON/OFF** function (allows you to activate/deactivate the channel).

When this option is selected a new field ("GPO") associated with each one of the faders is shown and allows to assign that GPO (it can also be defined in the advanced configuration menu of the input channel: see section 4.2.3.1 of this manual). You can not associate the same GPO to several channels.

Snapshot Configuration

Label  
test 1

12 Faders

Fader 01	Fader 06	Fader 11
A TB MIC	A MIC 5	A ANA 4
B None	B None	B None
None	None	None
GPO	GPO	GPO
Fader 02	Fader 07	Fader 12
A MIC 1	A MIC 6	A ANA 5
B DIG 1	B None	B None
GPO03	None	None
GPO	GPO	GPO
Fader 03	Fader 08	
A MIC 2	A ANA 1	
B DIG 2	B None	
GPO04	GPO07	
GPO	GPO	
Fader 04	Fader 09	
A MIC 3	A ANA 2	
B DIG 3	B None	
None	None	
GPO	GPO	
Fader 05	Fader 10	
A MIC 4	A ANA 3	
B DIG 4	B None	
None	None	
GPO	GPO	

- "Studio Monitoring Defaults"**: section where you can configure the initial activation of one or several keys to send signal to monitor and headphones placed under the display of the **studio** monitoring section. The available options are "Program", "Audition", "Cue" and "Sel" (when section is configured in "**Exclusive**" mode, you can activate only one key: see section 4.2.4.1 of this manual). "**Sel Input**" and "**Sel Out**" drop-down menus allow you to select a single input, output or internal summing bus to associate it initially with the "SEL" monitoring key (that selection can be modify later by means of "HP/SEL" encoder).

Studio Monitoring Defaults

Program  Cue

Audition  Sel

Sel Input  
DIG 1

Sel Out  
None

- "Control Monitoring Defaults"**: section where you can configure the initial activation of one or several keys to send signal to monitor and headphones placed under the display of the **control** monitoring section. The available options are "Program", "Audition", "Cue" and "Sel" (when section is configured in "**Exclusive**" mode, you can activate only one key: see section 4.2.4.1 of this manual). "**Sel Input**" and "**Sel Out**" drop-down menus allow you to select a single input, output or internal summing bus to associate it initially with the "SEL" monitoring key (that selection can be modify later by means of "HP/SEL" encoder).

**Control Monitoring Defaults**

Program  Cue

Audition  Sel

Sel Input

Sel Out

- **"Configure Inputs & Outputs"**: this button gives you a quick access to the advanced configuration section for audio inputs and outputs channels, presented in two consecutive columns.



**Configure Inputs & Outputs** ×

**test 1**

**Inputs**

Input	Label	Config
1	MIC 1	Click to [CON
2	MIC 2	Click to [CON
9	MIC 3	Click to [CON
10	MIC 4	Click to [CON
33	ANA 1	Click to [CON
35	ANA 2	Click to [CON
37	ANA 3	Click to [CON
39	ANA 4	Click to [CON
57	DIG 1	Click to [CON
59	DIG 2	Click to [CON
61	DIG 3	Click to [CON
63	DIG 4	Click to [CON
65	USB 1	Click to [CON
67	USB 2	Click to [CON
69	USB 3	Click to [CON
71	USB 4	Click to [CON
86	TEL 1	Click to [CON

**Outputs**

Outpu	Label	Config
49	ana 1	Click to [CONF
51	ana 2	Click to [CONF
53	ana 3	Click to [CONF
55	ana 4	Click to [CONF
57	dig 1	Click to [CONF
59	dig 2	Click to [CONF
61	dig 3	Click to [CONF
63	dig 4	Click to [CONF
65	usb 1	Click to [CONF
67	usb 2	Click to [CONF
69	usb 3	Click to [CONF
71	usb 4	Click to [CONF
85	tel 1	Click to [CONF
93	tel 2	Click to [CONF

- **"OK"**: allows you to accept the created or edited configuration.
- **"Cancel"**: allows you to reject the created or edited configuration. No change you may have made is saved.

#### 4.3.5.1. Advanced configuration of inputs.

Within the "Configure Inputs & Outputs" advanced configuration screen, the left part of the screen shows the complete list of all the available audio input channels. Three columns are shown:

- **"Input"**: shows the internal numeric identifier for the input.
- **"Label"**: shows the name or label associated with the channel.
- **"Config"**: allows you to configure the associated options for that input channel from a specific screen. You can access by clicking **"Click to [CONFIG]"** and then clicking again on the  button that will appear.

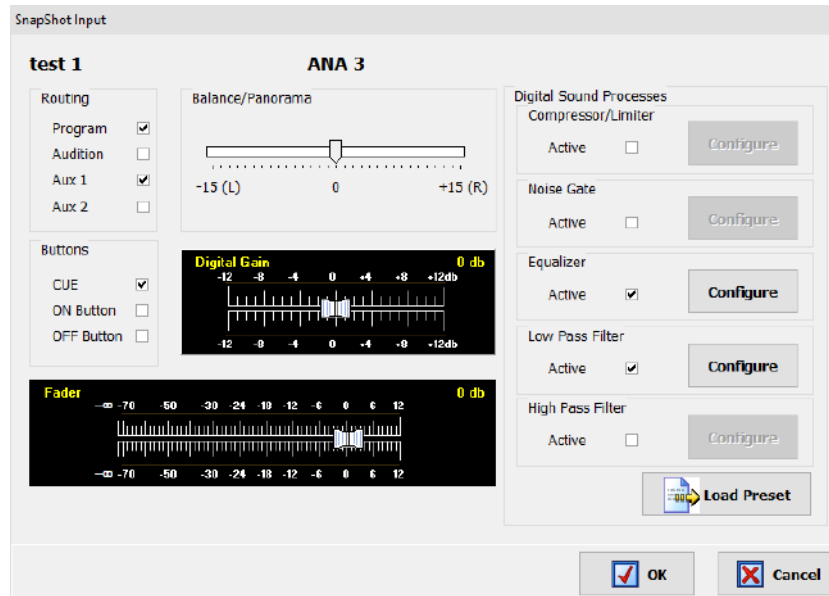

From left to right and from top to bottom the available options are:

- Name of the snapshot (test 1 in the example).
- Name of the channel (ANA 3 in the example).
- **"Routing"**: allows you to configure the initial activation (or not) of the quick routing keys that are available above each fader channel of AEQ FORUM control surface.
- **"Balance/Panorama"**: allows you to manage the initial balance or panoramic control for this input channel.
- **"Buttons"**: allows you to configure the initial status of the PFL sending button ("**CUE**") and the CHANNEL ON/OFF keys of AEQ FORUM control.
- **"Digital Gain"**: allows you to control the initial input gain of the selected channel from -12dB to +12 dB, by means of a graphical representation of a sliding fader (from -36 to +19dB in the case of microphone/line inputs).
- **"Fader"**: allows you to configure the initial virtual position of that channel fader. **IMPORTANT NOTE:** This configuration will take effect when that channel is not associated with a physical fader in the control surface; when it's associated with a fader, the value corresponding to that physical fader position will be taken.
- **"Digital Sound Processes"**: allows you to configure and activate/deactivate initially the available processes for that channel or, by means of "**Load Preset**" button, to select and load a previously created preset (see section 4.3.4).
- **"OK"**: allows you to accept the created or edited configuration.
- **"Cancel"**: allows you to reject the created or edited configuration. No change you may have made is saved.

In case you select any of the microphone/line inputs, an additional option appears at the bottom of the screen:

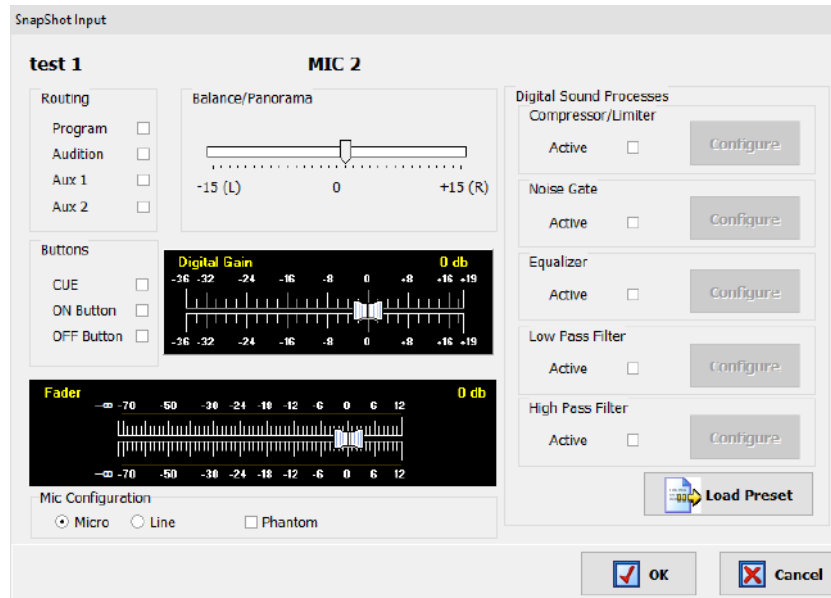

- **"Mic Configuration"**: this option allows you to configure the selected input as a microphone or line input and, if configured as microphone, it allows you to activate or not the Phantom power. This configuration is only applied when the edition of the common I/O's module or the Mic/Line inputs module (FR03S) doesn't include selectors to accomplish that configuration.

#### 4.3.5.2. Advanced configuration of outputs.

Within the "Configure Inputs & Outputs" advanced configuration screen, the right part of the screen shows the complete list of all the available audio output channels. Three columns are shown:

- **"Output"**: shows the internal numeric identifier for the output.
- **"Label"**: shows the name or label associated with the channel.
- **"Config"**: allows you to configure the associated options for that output channel from a specific screen. You can access by clicking **"Click to [CONFIG]"** and then clicking again on the  button that will appear.

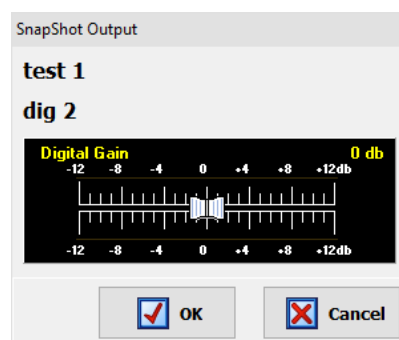

From left to right and from top to bottom the available options are:

- Name of the snapshot (test 1 in the example).
- Name of the channel (dig 2 in the example).
- **"Digital Gain"**: allows you to control the output gain of the selected channel from -12dB to +12 dB, by means of a graphical representation of a sliding fader.
- **"OK"**: allows you to accept the created or edited configuration.
- **"Cancel"**: allows you to reject the created or edited configuration. No change you may have made is saved.

#### 4.4. "Firmware Upgrade" menu.

This menu allows you to update the firmware versions for the AEQ FORUM, allowing for the implementation of new features and developments in future versions. Clicking on the "Firmware Upgrade" section on the main screen, the left side of the screen will show you the list of submenus, which includes:

- **"Tree View"**: provides a global view of the system, providing information regarding the currently installed firmware versions for each of the integrated and optional modules that AEQ FORUM mixing console contains.
- **"Upgrade View"**: shows information regarding the system functional module to be updated and the overall progress of the Firmware Upgrade operation.
- **"Log View"**: log containing all the actions associated with an upgrade process.

**IMPORTANT NOTE:** Any operation in this "Firmware Upgrade" section of the "Forum IP Setup" application should only be accomplished by qualified personnel in possession of all necessary technical information relative to this system and with the possibility to establish a direct communication with **AEQ's Technical Service** (support@aeq.es). Depending on the previous versions of the console, after upgrading process the console may lose its configuration, so **it's always recommended to save the console configuration** in a **FSC** file by means of "Export" option in "Forum IP Setup" application (see section 4.1.1 of this manual).

In order to execute this menu available options, it is necessary that the "Forum IP Setup" application is in direct communication with the AEQ FORUM mixer, through one of the 2 Ethernet ports. In case there is no connection to console, the associated submenus will be shown blank.

##### 4.4.1. "Tree View" submenu.

"Tree View" submenu is accessed, from the drop-down menu "Firmware Upgrade", by clicking on the icon:



"Tree View" submenu provides a global view of the system, with a tree structured diagram, providing information regarding the currently installed firmware versions for each of the integrated and optional modules that AEQ FORUM mixing console contains.

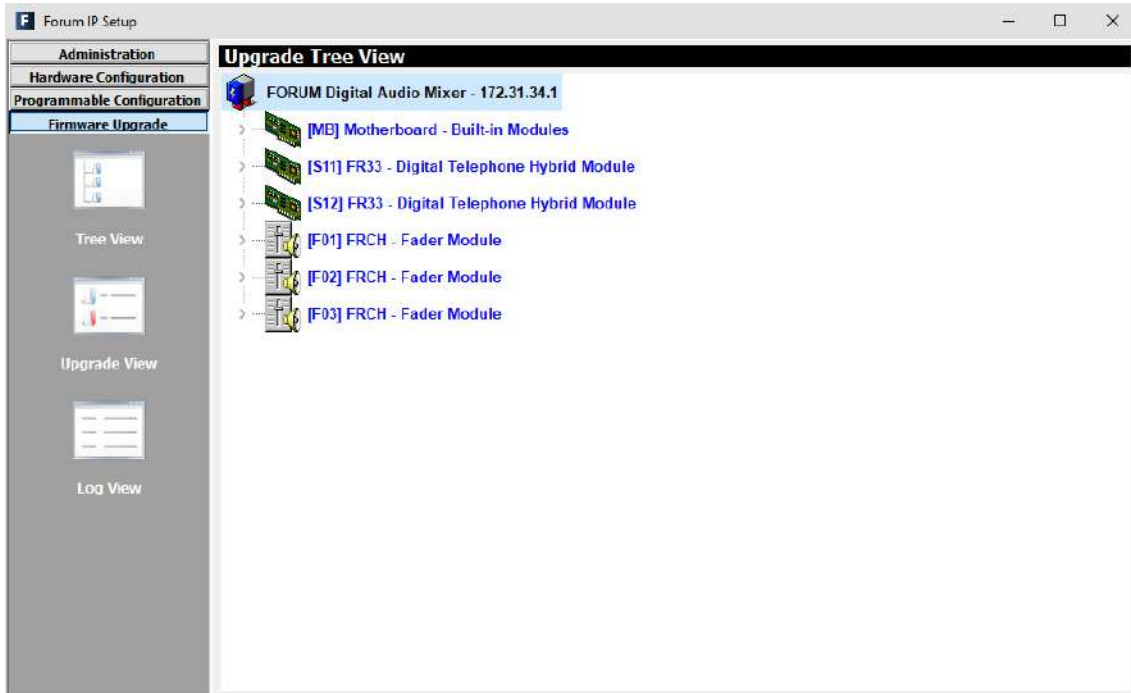

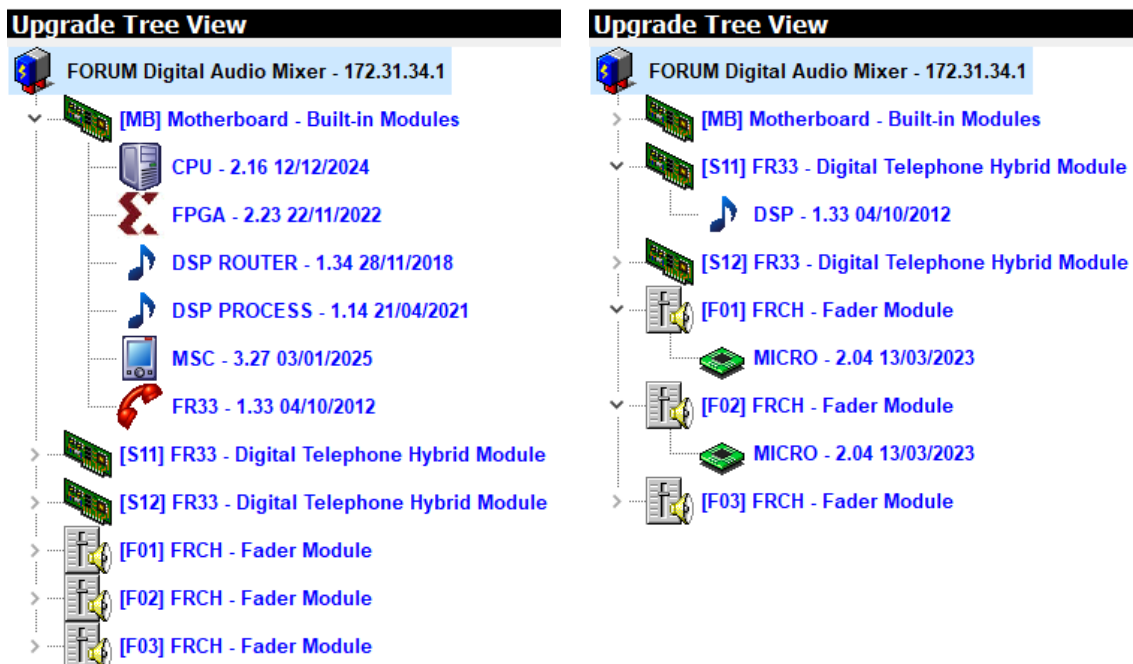

Selecting any of the modules, the associated firmware information will be shown.

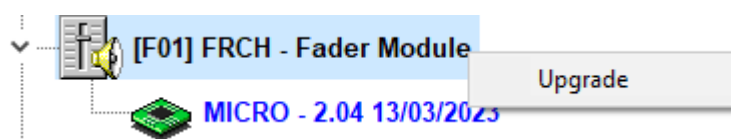

The procedure to upgrade a module firmware is as follows:

1. Place the pointer on the module to be upgraded, press the right mouse button and then the "**Upgrade**" option that appears.



- In the new window that appears, press the  button and select the "AFU" upgrading file (AEQ Firmware Upgrade) that contains the new version you want to load.

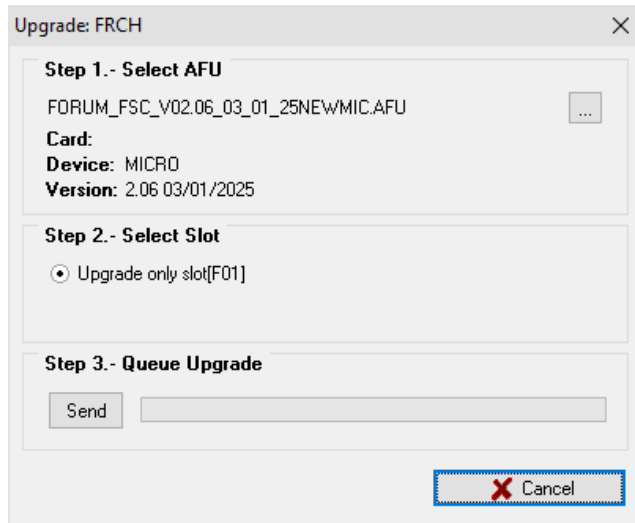

In case you select an AFU file that does not correspond to the selected module, an error message will be displays:



- Then press "**Send**" button to start the upgrading process.
- From this point on, the application changes automatically to "**Upgrade View**" screen in order to show you the upgrading progress. See section 4.4.2 of this manual.

**IMPORTANT NOTE:** You should not act on the system and you must never turn off the equipment during the upgrading process, since this action may deprogram the module that you are trying to upgrade. The **firmware upgrade right order** is: **BASE PBA** (CPU, FPGA, DSP Process and DSP Router), **FR33 module/s**, **MSC module** and **FRCH module/s**. After upgrading both the FPGA and the MSC module, the unit must be turned off/on. Before upgrading the FRCH modules, you must send configuration so they appear reflected again. The **FR33** telephone hybrid modules will appear as an upgradeable module inside the base board (as well as independent modules) and will be upgraded from here. The **AoIP** modules will be upgraded by means of "**DANTE Firmware Update Manager**" application.

In the case of the **FRCH** and **MSC** modules there are several board editions and some of them have associated exclusive firmware versions. In case you select an AFU file that does not correspond to the board edition, an error message will be displayed:



#### 4.4.2. "Upgrade View" submenu.

"Upgrade View" submenu is accessed, from the drop-down menu "Firmware Upgrade", by clicking on the icon (although the application will change automatically to this submenu when a firmware upgrading is in process):



"Upgrade View" submenu allows you to check in real time the upgrading progress.

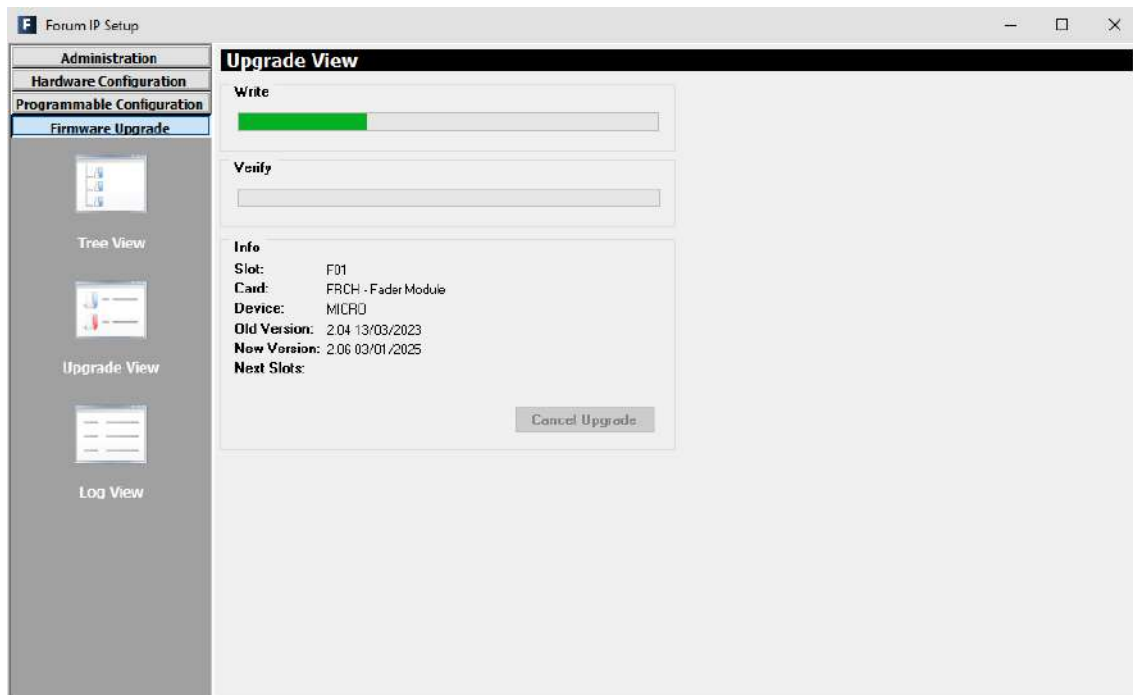

The following fields are visible on screen:

- **"Write"**: progress bar concerning the AFU file copy process from the computer that is running "Forum IP Setup" application to the AEQ FORUM IP internal memory.
- **"Verify"**: progress bar for the AFU file check previously copied to the AEQ FORUM IP internal memory.
- **"Info"**: displays information about the functional module of the AEQ FORUM IP subject to the firmware upgrade:
  - **"Slot"**: identifies the physical location of the module to be upgraded. In the case of a module placed at the rear panel of the AEQ FORUM, the slot where it is placed will be shown (S13 for instance). In case of a FRCH 4 faders module, its position will be shown (F01, F02 or F03). In case of a base board module, MB (Mother Board) indication will be shown.
  - **"Card"**: shows the type of the functional module that is subject to the firmware upgrade.
  - **"Device"**: electronic component part of the functional module that will be upgraded.
  - **"Old Version"**: information regarding the old firmware version installed on the component.
  - **"New Version"**: information about new firmware version installed on the component.

- **"Next Slots"**: indicates the position of the following functional modules to be upgraded.

#### 4.4.3. "Log View" submenu.

"Log View" submenu is accessed, from the drop-down menu "Firmware Upgrade", by clicking on the icon:



"Log View" submenu represents the record containing all the actions associated with a particular upgrade process as a sequence of independent events chronologically ordered and its specific status (OK or ERROR). This information is complementary information to "Tree View" and "Upgrade View" submenus.

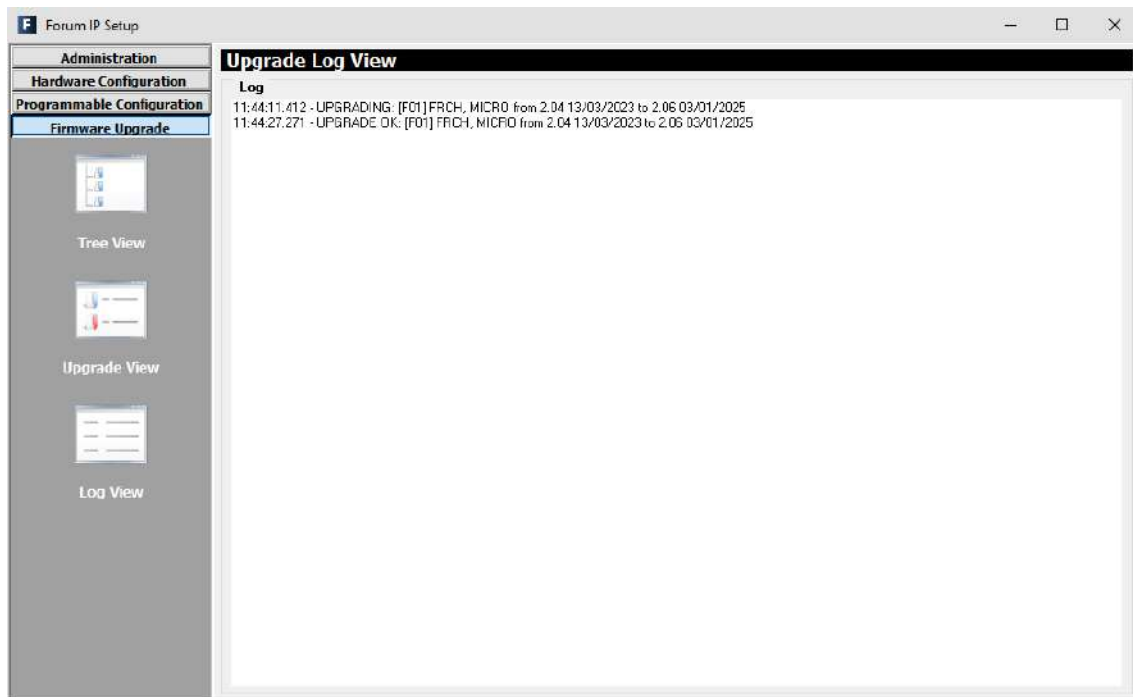

## **5. A.E.Q. GUARANTEE.**

AEQ warrants that this product has been designed and manufactured under a Quality Assurance System. AEQ therefore warrants that the necessary test protocols to assure the proper operation and the specified technical characteristics of the product have been followed and accomplished.

This includes that the general protocols for design and production and the particular ones for this product are conveniently documented.

1.- The present guarantee does not exclude or limit in any way any legally recognized right of the client.

2.- The period of guarantee is defined to be twelve natural months starting from the date of purchase of the product by the first client. To be able to apply to the established in this guarantee, it is compulsory condition to inform the authorized distributor or –to its effect- an AEQ Sales office or the Technical Service of AEQ within thirty days of the appearance of the defect and within the period of guarantee, as well as to facilitate a copy of the purchase invoice and serial number of the product.

It will be equally necessary the previous and expressed conformity from the AEQ Technical Service for the shipment to AEQ of products for their repair or substitution in application of the present guarantee.

In consequence, return of equipment that does not comply with these conditions will not be accepted.

3.- AEQ will at its own cost repair the faulty product once returned, including the necessary labour to carry out such repair, whenever the failure is caused by defects of the materials, design or workmanship. The repair will be carried out in any of the AEQ authorized Technical Service Centre. This guarantee does not include the freight charges of the product to or from such Authorized Technical Service Centre.

4.- No Extension of the Guarantee Period for repaired product shall be applied. Nor shall a Substituted Products in application of this Guarantee be subject to Guarantee Period Extension.

5.- The present guarantee will not be applicable in the following situations:

Improper use or Contrary use of the product as per the User or Instruction Manual; violent manipulation; exhibition to humidity or extreme thermal or environmental conditions or sudden changes of such conditions; electrical discharges or lightning; oxidation; modifications or not authorized connections; repairs or non-authorized disassembly of the product; spill of liquids or chemical products.

6.- Under no circumstances, whether based upon this Limited Guarantee or otherwise, shall AEQ, S.A. be liable for incidental, special, or consequential damages derived from the use or from the impossibility of using the product.

AEQ shall not be liable for loss of information in the disks or data support that have been altered or found to be inexact, neither for any accidental damage caused by the user or other persons manipulating the product.

## APPENDIX A. SIGNALLING CONNECTION.

Next, an example of connection of red light signalling in studio and control rooms is described.

The pinout of the DB9 connectors of "RELAY" section is detailed in section 2.2.2.1.3 of this manual.

First of all, in the "Forum IP Setup" application, it's necessary to configure in the "Monitoring Configuration" submenu of "Hardware Configuration" menu which relays will be used for ON AIR signalling of studio and control rooms. See section 4.2.4 of this manual.

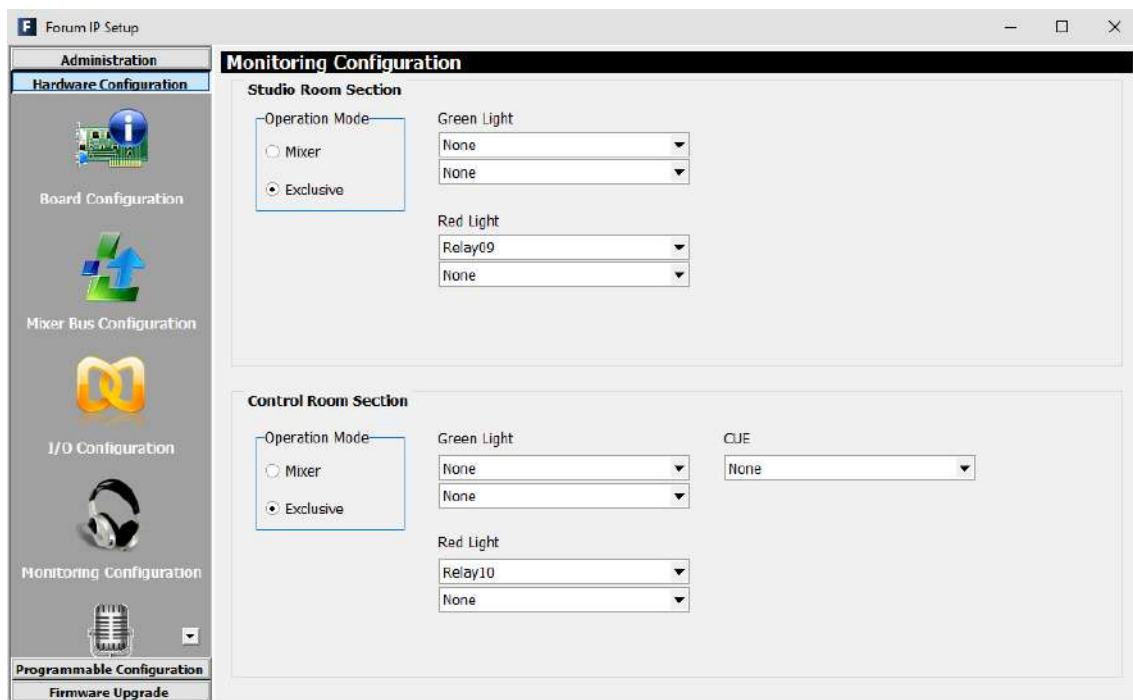

In the example, the first of the available relays ("Relay09") is assigned to the studio room red light and the second relay ("Relay10") to the control room red light. Once this section is configured, logically the configuration must be sent to the console.

Next, the connection to be made is detailed. Logically, if instead of using these 2 relays others are chosen, the connections indicated in the connection terminal should be adapted.

It's IMPORTANT not to connect the FR-CAB-RELE cable to the console before making the connections to the signalling system.

The connections in the terminal must be made with the power supply of the lights disconnected.

The handling and connection of the mixer, as well as the signalling wiring, must be carried out by qualified personnel. AEQ is not responsible for any damage caused to the mixer during installation, configuration or improper handling of the AEQ FORUM IP mixer.

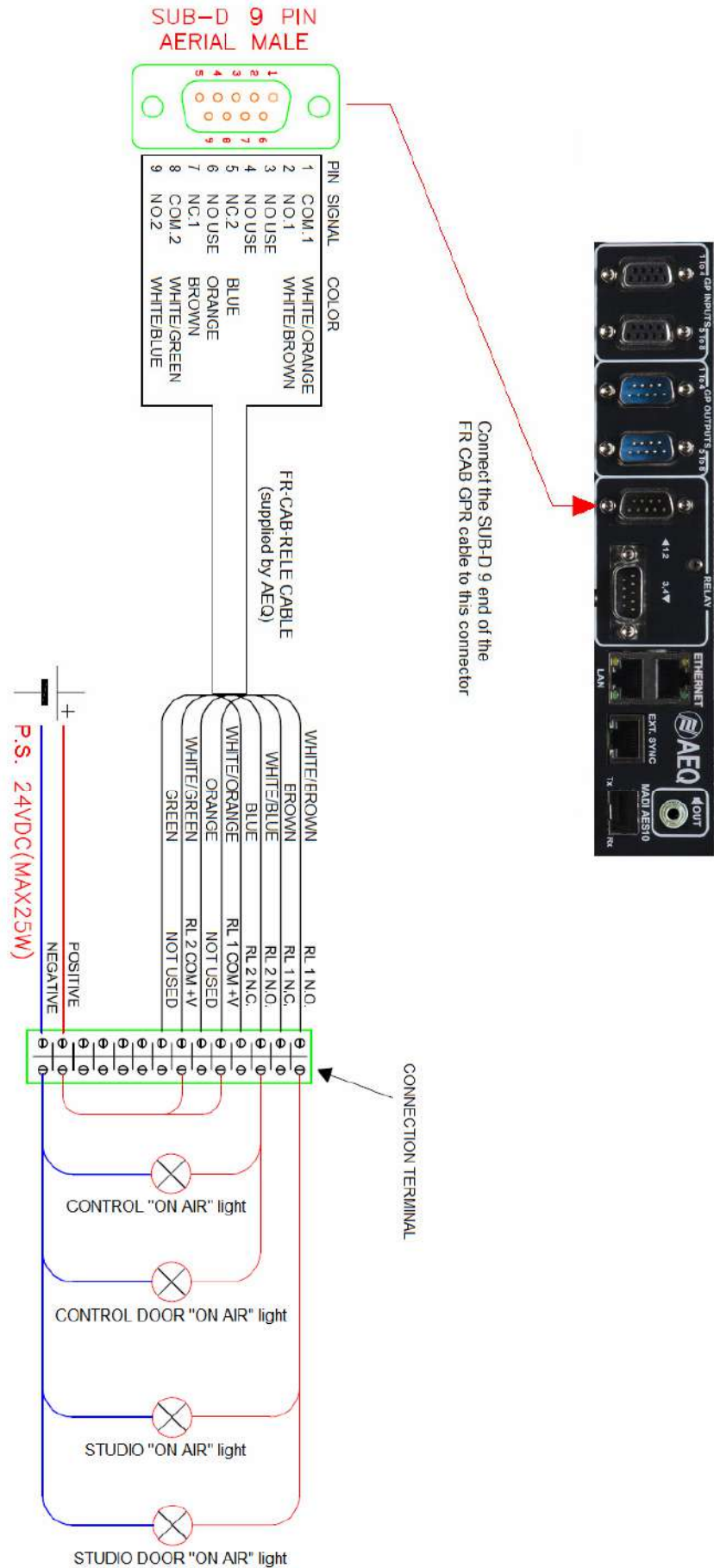

Connect the SUB-D 9 end of the FR CAB GPR cable to this connector



In case you also want to take the signalling to a **STUDIOBOX**, the previous scheme could be as follows:

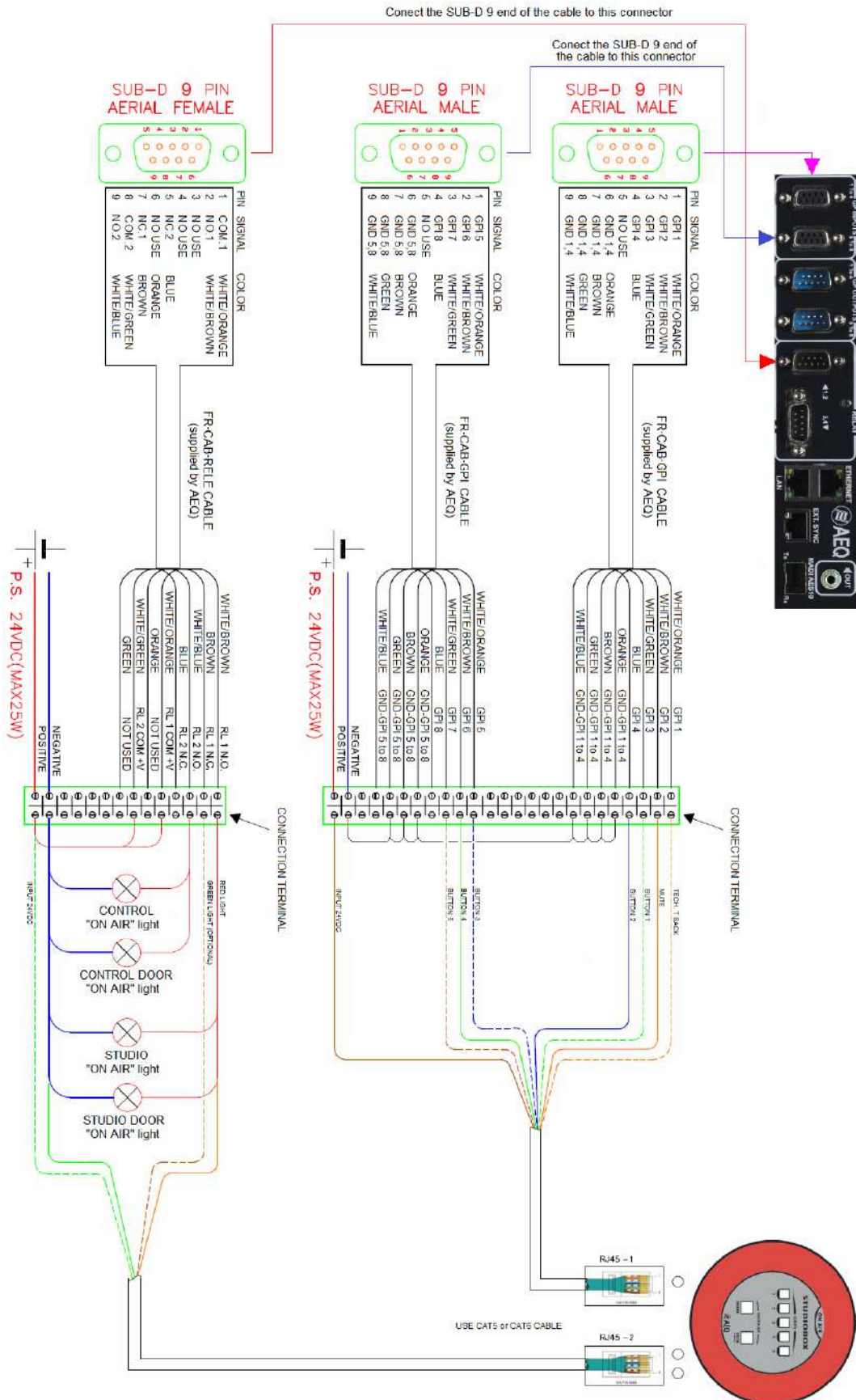

The color code of the RJ45 connectors that go to the STUDIOBOX is as follows:

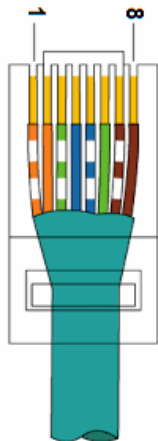

PIN	COLOR
1	White/Orange
2	Orange
3	White/Green
4	Blue
5	White/Blue
6	Green
7	White/Brown
8	Brown

The diagram also shows the connection associated with the buttons of the STUDIOBOX signaling box (RJ45-1). The corresponding cables will be connected to "GP INPUTS 1 To 4" and "GP INPUTS 5 To 8" DB9 connectors of the console.

This connection will also be associated with previous programming in the "Forum IP Setup" application. In the example, the "TECH T. BACK" button of the STUDIOBOX is connected to GPI 1 of the console and that GPI would be associated with the "Remote PFL" function of one of the console inputs. Similarly, the "MUTE" button is connected to GPI 2 of the console and that GPI would be associated with the "Cough Cut" or "Mute" function of one or more console inputs. On the other hand, USERS KEY 1 to 5 are respectively connected to GPIs 3 to 7 of the console and any of the functions available in the console could be associated to each of them (a "Remote ON/OFF" of an input or the activation of a salvo for example). See sections 4.2.3.1 and 4.3.2 of this manual.

## APPENDIX B. ADDITIONAL INFORMATION.

**NOTE:** This equipment complies with the limits for a Class A digital device, pursuant to part 15 of the **FCC** Rules. These limits are designed to provide reasonable protection against harmful interference when the equipment is operated in a commercial environment. This equipment generates, uses, and can radiate radio frequency energy and, if not installed and used in accordance with the instruction manual, may cause harmful interference to radio communications. Operation of this equipment in a residential area is likely to cause harmful interference in which case the user will be required to correct the interference at his own expense.



**Dante™** is a trademark of **Audinate Pty Ltd.**

Product includes license from Audinate Pty Ltd under US patent number(s) 7747725, 8005939, 7978696, 8171152 and others. Visit Audinate website for more details on Dante:  
<http://www.audinate.com/>