

Meisinger

# BONE MANAGEMENT® CATALOGUE 2021 / 22

BONE  
AUGMENTATION  
TECHNIQUES

– YOUR KEY  
TO SUCCESS





# INTERNATIONAL BONE MANAGEMENT® NETWORK



## BONE MANAGEMENT® ACADEMY

Bei der Entwicklung unserer chirurgischen Systeme und Instrumente ist uns nicht nur höchste Qualität „Made in Germany“, sondern auch die korrekte Anwendung dieser ein großes Anliegen. Da für eine erfolgreiche Implantat-Versorgung die fachgerechte Vorbereitung des knöchernen Implantatlagers unerlässlich ist, hat MEISINGER in Zusammenarbeit mit führenden Wissenschaftlern und Praktikern ein mehrstufiges Schulungskonzept entwickelt. Mit der Bone Management® Academy haben sowohl routinierte Anwender als auch Einsteiger die Möglichkeit, sich intensiv mit den Themen Knochenaugmentation, Implantologie sowie Inhalten rund um das Praxismanagement zu beschäftigen und sich in diesem Bereich weiterzubilden.

When developing our surgical systems and instruments, we are not only concerned with the highest quality of "Made in Germany", but also with the correct application of these systems and instruments. Since the professional preparation of the bony implant site is essential for successful implant placement and management, MEISINGER has developed a multi-level training concept in cooperation with leading scientists and practitioners. With the Bone Management® Academy, both experienced users and beginners have the opportunity to deal intensively with the topics of bone augmentation, implantology, content related to practice management as well as providing the chance to further their education in this field.



Made in Germany. Supported by





Die Hauptmotivation liegt in dem kontinuierlich steigenden Mehrwert für die Teilnehmer. Es stehen somit nicht die von MEISINGER entwickelten Systeme im Vordergrund, sondern das professionelle, praxisnahe sowie patientenorientierte Handeln, welches in den Kursen erlernt werden kann. Hochwertige und präzise gefertigte Produkte spielen dabei zwar eine wesentliche Rolle für den späteren Erfolg beim Patienten. Die richtige und professionelle Anwendung ist jedoch der berühmte „Schlüssel zum Erfolg“ und damit auch der beste Weg zum zufriedenen Patienten.

Daher scheuen wir auch nicht den Wettbewerb, sondern beziehen bewusst weitere Dental-Unternehmen ein, um unseren Teilnehmern eine neutrale Sichtweise zu ermöglichen und konkurrierende Behandlungsmethoden zu thematisieren. Wenn die Teilnehmer bestimmte Techniken für gut befinden, können die Produkte zunächst intensiv in Workshops ausprobiert und einstudiert werden. Zusätzliche Hospitationen und Supervisionen bieten weitere Möglichkeiten, das Erlernete zu intensivieren und so eine bewusste Entscheidung zu treffen.

Eine Orientierungshilfe für Studenten und Assistenzärzte für eine spätere Spezialisierung bieten schon die mehrmals im Jahr stattfindenden Young dental experts Camps. Angehende Chirurgen können sich zudem in verschiedenen Kursen und Workshops solides Basiswissen aneignen. Die richtigen Naht- und Schnitttechniken sind dabei genauso wichtig wie das richtige Verständnis für das Weich- und Hartgewebe. Innerhalb des Curriculums können zudem verschiedene Augmentations-techniken erlernt und geübt werden. Die Bone Management® Academy umfasst darüber hinaus auch komplexe Techniken, wie die von Prof. Dr. Fouad Khoury entwickelte Karotten- sowie Schalentechnik oder die Sausage Technique nach Prof. Dr. Istvan Urban.

Our main motivation is on the continuously increasing added value for participants. The focus is therefore not on the systems developed by MEISINGER, but on professional, practical, and patient-oriented techniques that can be learned in the courses. High-quality and precisely manufactured products play an essential role in positive and successful patient outcomes. However, the correct and proficient application of these tools is the famous "key to success" and thus also the best way to a satisfied patient.

That is why we do not shy away from our competition, but deliberately involve other dental companies in order to enable our participants to form a balanced perspective, and to discuss and compare competing treatment methods. If the participants find certain techniques to be good, the products can firstly be intensively tested and practiced in the workshops. Additional work shadowing and supervision offer further opportunities to consolidate what has been learned and thus make better informed decisions.

The Young dental experts camps, which take place several times a year, also offer orientation aid for students, interns, and residents in their future specialization choice. Aspiring surgeons can also acquire solid basic knowledge in the various courses and workshops. The right suturing and cutting techniques are just as important as the right understanding of soft and hard tissue. Various augmentation techniques can also be learned and practiced within the curriculum. The Bone Management® Academy also includes complex techniques such as the Carrot and Shell techniques developed by Prof. Dr. Fouad Khoury or the Sausage technique according to Prof. Dr. Istvan Urban.



MEISINGER USA Headquarters, Colorado



MEISINGER Germany Headquarters, Neuss

## STANDORTE / LOCATIONS HAGER & MEISINGER GMBH:



MEISINGER GERMANY



MEISINGER USA



MEISINGER FRANCE SARL



MEISINGER ASIA CO. LTD.



## STANDORTE / LOCATIONS

### MYPLANT GMBH:



MYPLANT UK & IRELAND LTD.



MYPLANT TÜRKIYE AS



MYPLANT ITALIA S.R.L.

# INHALT/CONTENT

---

## 08 ROOT EXTRACTION

---

08-09 CBE00 | Benex®-Control

## 10 BONE SPREADING

---

10-11 CCR00 | Crest-Control  
12-13 CSP12 | Split-Control 12 mm  
14-15 CSPPL | Split-Control Plus  
16-17 BSPPR | Split-Control Professional

## 20 BONE MANAGEMENT® MASTER-LINE

---

22 BMCBA | Master-Core Basic  
23 BMCPR | Master-Core Professional  
24-25 BKM00 | Master-Mill  
26 BMPBA | Master-Pin-Control Basic  
27 BMP00 | Master-Pin-Control

## 28 BONE MANAGEMENT® KHOURY-LINE

---

30-31 BTE00 | Trephine Ejection Kit  
32 BMSBA | Micro Screw System Basic  
33 BMS00 | Micro Screw System  
34-35 BOSTO | Ost-Tray  
36 BSINO | Sinus-Tray  
37 BSOTO | Soft-Tissue-Tray  
38-39 BS003,BS004 | SAFESCRAPER® Twist

## 42 BONE TRANSFER & OSTEOSYNTHESIS

---

42-43 CTRBA | Transfer-Control Basic  
44-45 CTR00 | Transfer-Control  
46 CTRIO | Transfer-Ring-Control I  
47 BBR00 | Transfer-Ring-Control II  
48-49 CTRPL | Transfer-Control Plus  
50 BTX00 | Screw System TX  
51 BTXPR | Screw System TX Professional  
52 7120 | Threphine Basic Kit  
53 7121 | Threphine Kit  
54 7122 | Threphine Kit Long  
55 7140 | Punch Basic Kit  
55 7150 | Saw Basic Kit

## 56 SINUSLIFT

---

56 CCLBA | Crestal-Lift-Control Basic  
57 BCL00 | Crestal-Lift-Control  
58 BTL00 | External-Lift-Control  
59 CSL00 | Internal-Lift-Control  
60-61 BLIPL | Lift-Control Plus  
62 BSKSL | Surgical Kit 1  
63 BSK02 | Surgical Kit 2

## 64 IMPLANT SITE PREPARATION

64	BSK03	Surgical Kit 3
64	BSK04	Surgical Kit 4
65	ALV18	Alveoplasty Surgical Kit
66	IPK02	Implant Preparation Kit with Stop
67	BDS00	Drill-Stop-Control (BL + TL)
68	BDS02	Drill-Stop-Control (BLT)
69	BDSMP	Drill-Stop-Control (myplant two)
70-71	BGS00	Guided-Drill-Stop-Control
72	BNA00	3D-Navigation-Control
73	BNAPR	3D-Navigation-Control Professional

## 74 PERIIMPLANTITIS

74	2575	Periimplantitis Kit
75	DEG00	Degranulation Kit

## 76 MEMBRANES & SUTURES

76	MEISINGER	Porcine Collagen Membrane
77	MEISINGER	Bovine Collagen Membrane
78	MEISINGER	dPTFE Membrane
79-81	MEISINGER	Titanium-Reinforced dPTFE Membrane
82-83	Cytoplast™	Reinforced PTFE Mesh
84	Cytoplast™	RTMPlug, RTMFoam, RTMTape
85	MEISINGER	PTFE Suture
86-89	Pro-Fix™	Membrane Fixation, Tenting, Bone Fixation

## 90 BONE GRAFTING MATERIAL

90-93	NanoBone®	granulate, block, QD
-------	-----------	----------------------

## 94 BONE MANAGEMENT® ACCESSORIES

94-95	CM01S	Easy-Clean Scissors
96-97	MEISINGER	Handinstrumente/Manual Instruments
98	MEISINGER	Ratschen/Ratchets
99-111	MEISINGER	Chirurgieinstrumente/Surgery Instruments
112-114	MEISINGER	Edelstahl-Bohrerstände/Stainless Steel Bur Blocks

**Hinweis:** Nicht alle Produkte, die in diesem Katalog gezeigt werden, sind in allen Ländern erhältlich.

**Note:** Not all products contained in this catalogue are available in all countries.



# Benex® -Control

Root Extraction System | developed with Dr. Benno Syfrig

Benex®-Control eignet sich hervorragend zum kontrollierten und sicheren Extrahieren von Zahnwurzeln und Zahnwurzelfragmenten, sodass die herkömmliche Methode der Extraktion mit Zange und Hebel vermieden werden kann. Dank der innovativen Konstruktion des Extraktors lässt sich die Wurzel ohne Verletzung von Knochen und Weichgewebe sehr leicht und besonders kontrolliert entfernen. Um eine optimale, vertikale Kraftübertragung zu garantieren, muss eine plane Ebene zur Auflage des Extraktors vorliegen. Die speziell für diesen Zweck entwickelte Quadrantenstütze bietet eben diese optimale Auflagefläche. Dabei schützt sie vorhandene Restbezaehlung und bietet insbesondere bei zahnlosen Verhältnissen eine stabile Auflage für den Extraktor.

Benex®-Control is outstandingly suitable for the controlled and safe extraction of dental roots and dental root fragments, so the conventional extraction method using forceps and leverage can be avoided. Thanks to the innovative construction of the extractor, the root can be easily removed in a particularly controlled manner without damaging bone or soft tissue. To guarantee an optimal vertical transmission of force, there must be a flat area providing a supporting surface to the extractor. The quadrant support was developed specifically to provide this optimal support while also protecting existing dentition and providing support for the extractor in case of edentulous circumstances.



Anwendungsvideo  
Application Video

Art.-No. CBE00



© Dr. Benno Syfrig



Fig.	859L*	A2001	B2001	BE001 060	BE001 070	BE001 080	BE001 085
Shank <sup>1</sup>	204	205	205	-	-	-	-
Size <sup>2</sup>	010	013	016	-	-	-	-
Length mm	12.0	15.0	15.0	10.0	16.0	10.0	16.0
	-	-	-	1.3	1.3	1.8	1.8
	1.0	1.3	1.6	1.6	1.6	2.1	2.1

<sup>1</sup> 204=RA, 205=RA L    <sup>2</sup> Größter Arbeitsteildurchmesser in 1/10 mm    <sup>3</sup> Largest working part diameter in 1/10 mm

Minimaldurchmesser Minimal diameter    Außendurchmesser External diameter

Optional erhältlich:  
Optionally available:

Teflon® Auflagerungsplatte (gerade)<sup>1</sup>  
Teflon® coated bite plate (straight)



Fig. BE001 015  
gerade | straight

Teflon® Auflagerungsplatte (abgeschragt)<sup>1</sup>  
Teflon® coated bite plate (beveled)



Fig. BE001 017  
links | left



Fig. BE001 018  
rechts | right

<sup>1</sup> Teflon® is a registered trademark of DuPont, USA

Fig. Periotom | Periotome    HI306

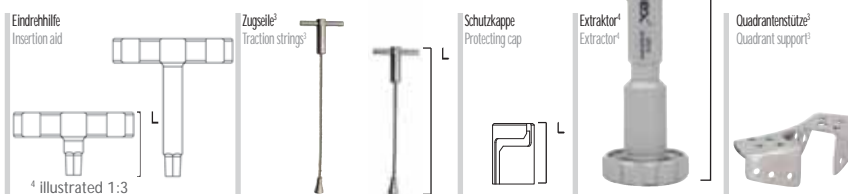
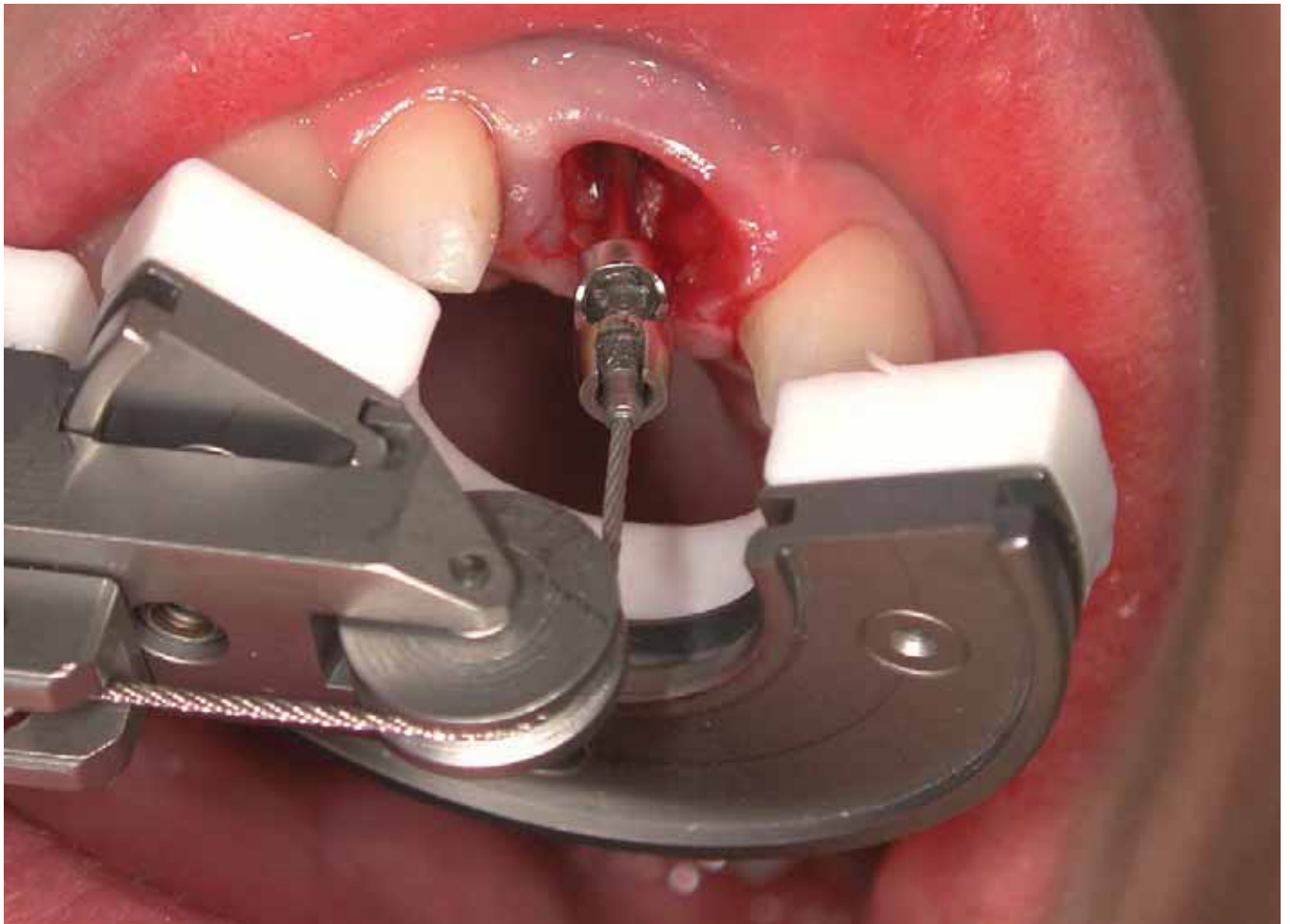

Fig.	BE001 045	BE001 055	BE001 020	BE001 021	BE001 SK60	BE001 010*	BE001 090
Length mm	8.2	18.2	48.0	39.0	8.0	129.0	-

Minimaldurchmesser Minimal diameter    Außendurchmesser External diameter

\* inkl. gerade Teflon® Auflagerungsplatte incl. straight Teflon® bite plate





## AUF EINEN BLICK

- Sichere und kontrollierte Wurzelextraktion
- Möglichkeit der Sofortimplantation
- Maximal mögliche Schonung der vestibulären Knochenwand durch vertikale Extraktion
- Optimaler Schutz von Knochen und Weichgewebe
- Anwendung auch bei kleinstem Wurzelrest
- Vermeidung von Osteotomie
- Hohe Patientenakzeptanz

## AT A GLANCE

- Safe and controlled extraction of roots
- Possibility of immediate implant placement
- Maximum preservation of the vestibular bone wall due to vertical extraction
- Optimal protection of bone and soft tissues
- Applicable to small root fragments
- Osteotomy can be prevented
- High patient acceptance

Developed with  
**Dr. Benno Syfrig**  
 Luzern, Switzerland





# Crest-Control

## Horizontal Bone Splitting System

Crest-Control ist ein Horizontal Bone Splitting System, das eine vorbestimmbare und minimalinvasive Verbreiterung des horizontal resorbierten Kieferkamm, insbesondere im distalen Unterkiefer, ermöglicht. Mit den bewährten Horizontal Spreadern kann der Kieferkamm einfach, schnell und kontrolliert um bis zu 5 mm verbreitert werden, sodass im Anschluss ein Implantat aller gängigen Systeme in das verbreiterte Segment eingesetzt werden kann.

Crest-Control is a Horizontal Bone Splitting System which allows for a predetermined and minimally invasive widening of the horizontally resorbed alveolar ridge particularly in the distal lower jaw. With the well-proven Horizontal Spreaders, the alveolar ridge can be expanded up to a maximum of 5 mm, allowing an implant of every common system to be inserted in the widened segment.



Anwendungsvideo  
Application Video

Art.-No. CCR00

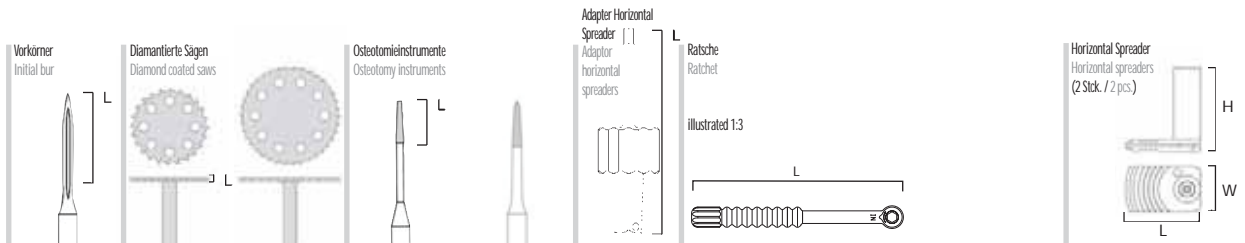

Fig.	186RF	231DC*	231DC*	HM331L**	HM254E**	SW0L1	CARA4
Shank <sup>1</sup>	204	204	204	205	205	-	-
Size <sup>2</sup>	018	100	130	010	012	-	-
Length mm	12.0	0.3	0.3	5.5	6.0	27.0	84.0
	-	-	-	-	-	-	-
	1.8	10.0	13.0	1.0	1.2	-	-

<sup>1</sup> 204=RA, 205=RA L    <sup>2</sup> Größter Arbeitsteildurchmesser in 1/10 mm    <sup>2</sup> Largest working part diameter in 1/10 mm

Minimaldurchmesser Minimal diameter    Außendurchmesser External diameter



Fig.	VCD50
Width mm	6.0
Length mm	9.75
Height mm	10.6
Lifting Height mm	Max. 5.0

Optional erhältlich:  
Optionally available:

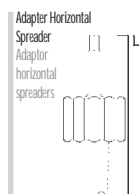

Fig.	SWOK1
Shank <sup>1</sup>	-
Size <sup>2</sup>	-
Length mm	22.0
	-
	-

Minimaldurchmesser Minimal diameter  
 Außendurchmesser External diameter

Horizontal Spreader

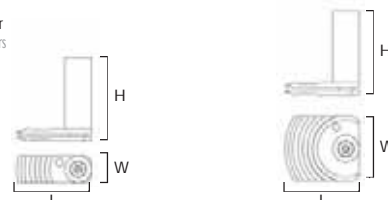
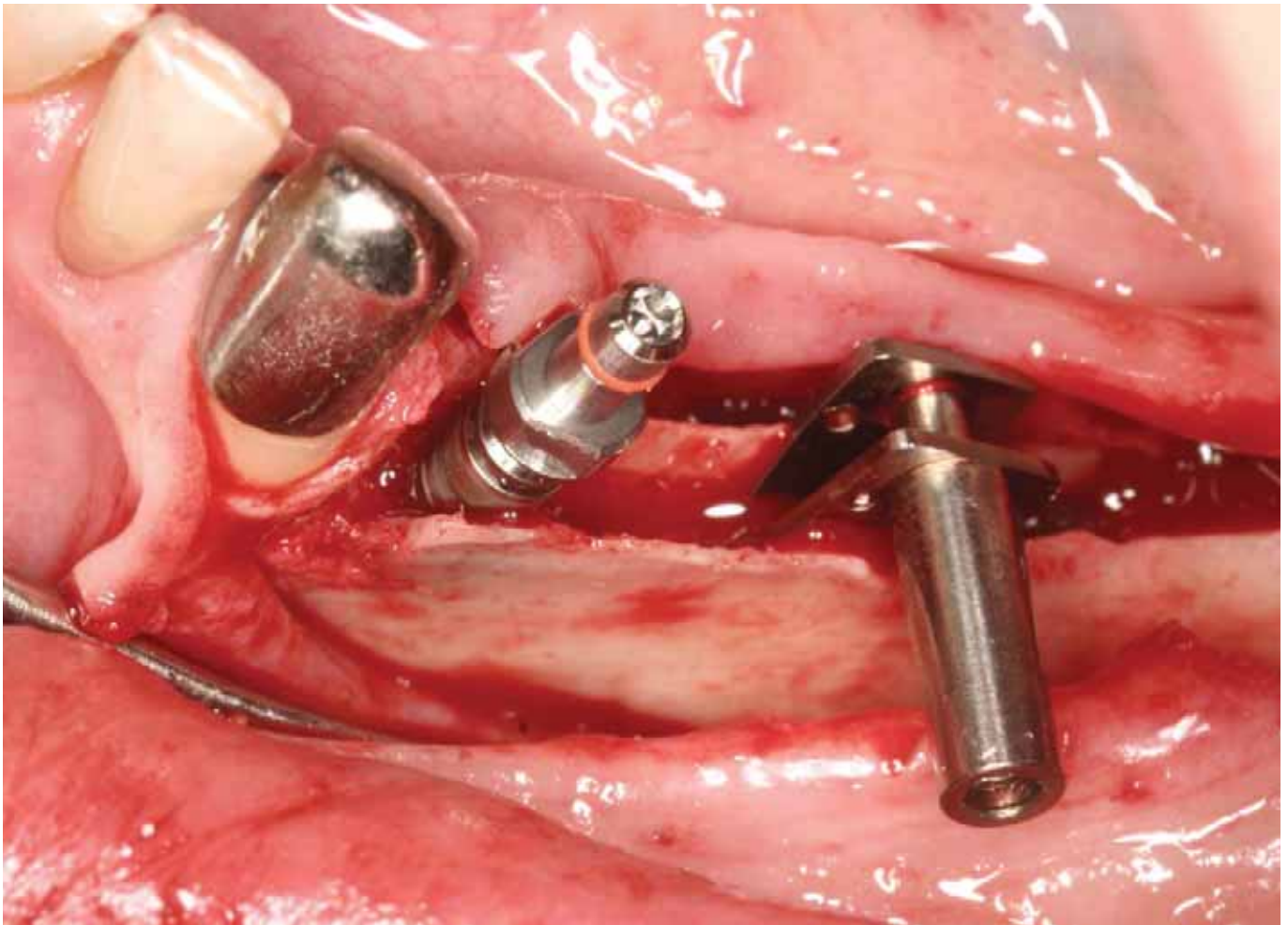

Fig.	VCD35	VCD85
Width mm	3.5	8.5
Length mm	9.75	9.75
Height mm	10.6	10.6
Lifting Height mm	Max. 5.0	Max. 5.0



## AUF EINEN BLICK

- Kontrolliertes Aufdehnen von horizontal resorbiertem Knochen
- Auch bei geringer Breite des Kieferkamms problemlos einsetzbar
- Vorbereitung des Knochens für alle gängigen Implantatsysteme
- Minimalinvasives Behandlungskonzept
- Sanfte Weitung des Kieferkamms

## AT A GLANCE

- Controlled widening of horizontally resorbed bone
- Effective in increasing the width of narrow alveolar ridges
- Preparation of the bone for all common implant systems
- Minimally invasive treatment concept
- Gentle widening of the alveolar ridge



# Split-Control 12 mm

## Bone Condensing and Bone Spreading System

Split-Control 12 mm ist ein System zur sanften Verbreiterung des Alveolarkamms und gleichzeitiger lateraler Knochenverdichtung bei horizontalem Knochendefizit. Mit Hilfe spezieller schraubenförmiger Verdichtungs- und Spreizinstrumente (Spreader) kann horizontal resorbierter Knochen kontrolliert und sanft aufgedehnt werden (Bone Spreading). Zusätzlich wird dabei spongioser Knochen dank der speziellen Geometrie der Spreader verdichtet (Bone Condensing) und so die Primärstabilität der inserierten Implantate erhöht.

Split-Control 12 mm enthält ein umfassendes Instrumentarium für die kontrollierte Kieferkammverbreiterung mit Spreadern der Länge 12 mm.

Split-Control 12 mm is a system for gentle widening of the alveolar ridge and simultaneous lateral bone condensing in the case of a horizontal bone deficit. With the aid of screw-like condensing and spreading instruments (Spreaders), it is possible to achieve a controlled and gentle dilatation of horizontally resorbed bone (Bone Spreading). Further, cancellous bone is condensed due to the special geometry of the spreaders (Bone Condensing), so that the primary stability of the inserted implants is increased.

Split-Control 12 mm provides an extensive range of instruments for a controlled dilatation with spreaders with a length of 12 mm.



Anwendungsvideo  
Application Video

Art.-No. CSP12

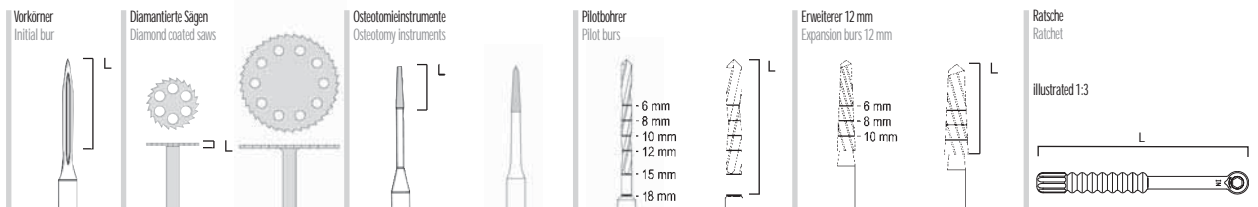

Fig.	186RF	231DC*	231DC*	HM33IL**	HM254E**	B1001	E1001	A2003	D2003	CARA4
Shank <sup>1</sup>	204	204	204	205	205	206	206	205	205	-
Size <sup>2</sup>	018	070	130	010	012	013	020	023	030	-
Length mm	12.0	0.3	0.3	5.5	6.0	18.0	18.0	12.0	12.0	84.0
	-	-	-	-	-	-	-	1.30	2.03	-
	1.8	7.0	13.0	1.0	1.2	1.3	2.0	2.3	3.0	-

<sup>1</sup> 204=RA, 205=RA L, 206=RA XL

<sup>2</sup> Größter Arbeitsteildurchmesser in 1/10 mm <sup>2</sup> Largest working part diameter in 1/10 mm

Minimaldurchmesser Minimal diameter Außendurchmesser External diameter

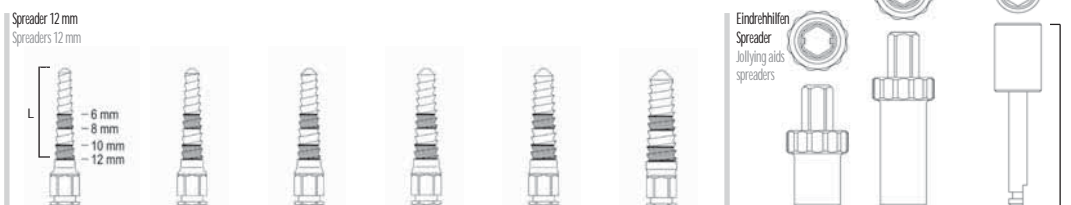
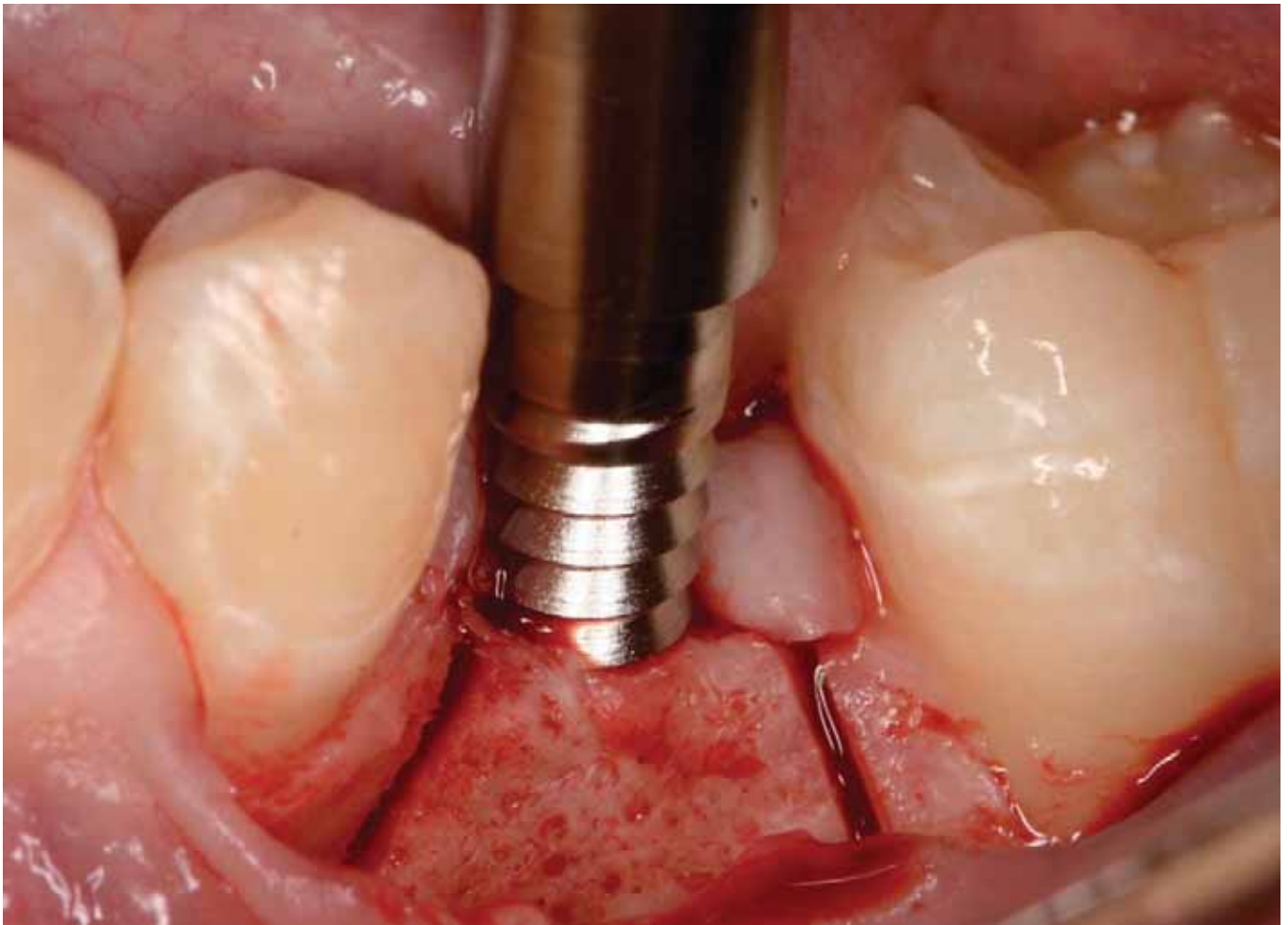

Fig.	A2005	B2005	C2005	D2005	E2005	F2005	CA1RB	CA0RB	CA8RA
Shank <sup>1</sup>	-	-	-	-	-	-	-	-	204
Size <sup>2</sup>	027	029	031	033	035	040	-	-	-
Length mm	12.0	12.0	12.0	12.0	12.0	12.0	18.0	25.0	24.0
	1.70	1.91	2.12	2.33	2.54	3.06	-	-	-
	2.7	2.9	3.1	3.3	3.5	4.0	-	-	-

<sup>1</sup> 204=RA

<sup>2</sup> Größter Arbeitsteildurchmesser in 1/10 mm <sup>2</sup> Largest working part diameter in 1/10 mm

Minimaldurchmesser Minimal diameter Außendurchmesser External diameter



## AUF EINEN BLICK

- Kontrolliertes Aufdehnen von horizontal resorbiertem Knochen
- Sanfte Knochenverdichtung durch nicht-schneidende Archimedes-Schrauben
- Erhöhte Primärstabilität der inserierten Implantate
- Auch bei geringer Breite des Kieferkamms problemlos einsetzbar
- Vorbereitung des Knochens für das Inserieren aller gängigen Implantatsysteme

## AT A GLANCE

- Controlled spreading of horizontally resorbed bone
- Gentle bone condensing with the aid of non-cutting Archimedes screws
- Increased primary stability of the inserted implants
- Effective in increasing the width of narrow alveolar ridges
- Preparation of the bone for all common implant systems



# Split-Control Plus

## Combination of Split-Control and Crest-Control

Split-Control Plus ist eine Kombination aus den bewährten Split-Control und Crest-Control Systemen und bietet somit ein umfassendes Instrumentarium für die kontrollierte Kieferkammverbreiterung. Es enthält sowohl spezielle schraubenförmige Verdichtungs- und Spreizinstrumente (Spreader), als auch flache Horizontal Spreader, die eine kontrollierte und einheitliche Spreizung von horizontal resorbiertem Knochen erlauben. Durch die schraubenförmigen Spreader wird spongioser Knochen zusätzlich sanft verdichtet, während die Horizontal-Spreader eine Spreizung des Kieferkamms um bis zu 5 mm ermöglichen. So wird der Kiefer optimal auf die Insertion eines am Markt gängigen Implantates vorbereitet.

Split-Control Plus is a combination of the proved Split-Control and Crest-Control systems, so it offers an extensive range of instruments for controlled bone spreading and condensing. It contains both specially designed screw-like condensing and spreading instruments (Spreader) and horizontal spreaders that allow for controlled and standardized spreading of horizontally resorbed bone. Due to the special geometry of the screw-like spreaders, cancellous bone is gently condensed while the Horizontal Spreaders allow for a dilatation up to a width of 5 mm, so the bone is optimally prepared for the insertion of every common implant.



Anwendungsvideo  
Application Video

Art.-No. CSPPL

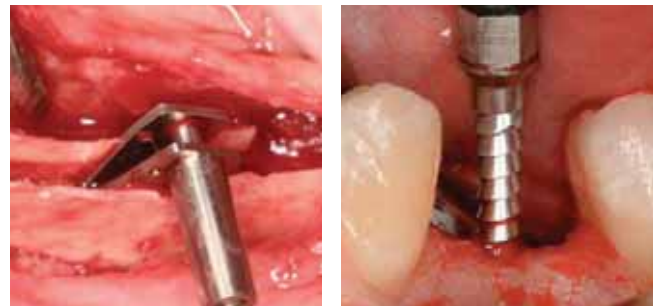

© Dr. Bayer & Drs. Kistler, © Dr. Raymond Kimsey, D.D.S.

	Vorkörner Initial bur	Diamantierte Sägen Diamond coated saws		Osteotomieinstrumente Osteotomy instruments		Pilotbohrer Pilot burs		Erweiterer 12 mm Expansion burs 12 mm	
Fig.	186RF	231DC*	231DC*	HM331L**	HM254E**	A1001	D1001	A2003	D2003
Shank <sup>1</sup>	204	204	204	205	205	206	206	205	205
Size <sup>2</sup>	018	100	130	010	012	010	018	023	030
Length mm	12.0	0.3	0.3	5.5	6.0	18.0	18.0	12.0	12.0
⚠	-	-	-	-	-	-	-	1.30	2.03
* □ *	1.8	10.0	13.0	1.0	1.2	1.0	1.8	2.3	3.0

<sup>1</sup> 204=RA, 205=RA L, 206=RA XL <sup>2</sup> Größter Arbeitsteildurchmesser in 1/10 mm <sup>2</sup> Largest working part diameter in 1/10 mm ⚠ Minimaldurchmesser Minimal diameter □ \* Außendurchmesser External diameter



	Spreader 12 mm Spreader 12 mm						Eindreihhilfen Jollying aids spreaders		Adapter Horizontal Spreader Adapter horizontal spreaders		Ratsche Ratchet illustrated 1:3	Horizontal Spreader Horizontal spreaders (2 Stck./2 pcs.)	
Fig.	A2005	B2005	C2005	D2005	E2005	F2005	CA1RB	CA8RA	SWOL1	CARA4	Fig.	VCD50	
Shank <sup>1</sup>	-	-	-	-	-	-	-	204	-	-	Width mm	6.0	
Size <sup>2</sup>	027	029	031	033	035	040	-	-	-	-	Length mm	9.75	
Length mm	12.0	12.0	12.0	12.0	12.0	12.0	18.0	24.0	27.0	84.0	Height mm	10.6	
⚠	1.70	1.91	2.12	2.33	2.54	3.06	-	-	-	-	Lifting Height mm	Max. 5.0	
* □ *	2.7	2.9	3.1	3.3	3.5	4.0	-	-	-	-			

<sup>1</sup> 204=RA <sup>2</sup> Größter Arbeitsteildurchmesser in 1/10 mm <sup>2</sup> Largest working part diameter in 1/10 mm ⚠ Minimaldurchmesser Minimal diameter □ \* Außendurchmesser External diameter



Optional erhältlich:  
Optionally available:

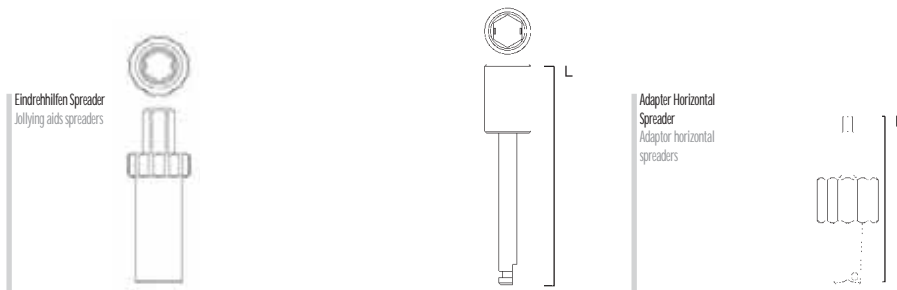

Fig.	CA0RB	CA9RA	SW0K1
Shank <sup>1</sup>	-	205	-
Size <sup>2</sup>	-	-	-
Length mm	25.0	29.0	22.0
	-	-	-
	-	-	-

<sup>1</sup> 205 = RA L

<sup>2</sup> Größter Arbeitsteildurchmesser in 1/10 mm<sup>2</sup> Largest working part diameter in 1/10 mm Minimaldurchmesser Minimal diameter Außendurchmesser External diameter

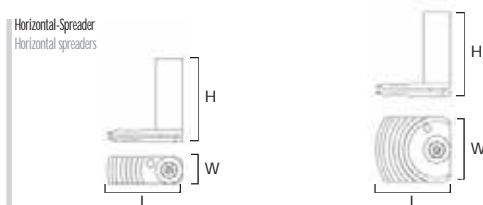

Fig.	VCD35	VCD85
Width mm	3.5	8.5
Length mm	9.75	9.75
Height mm	10.6	10.6
Lifting Height mm	Max. 5.0	Max. 5.0

## AUF EINEN BLICK

- Kombiniertes System aus Crest- und Split-Control
- Kombinationsmöglichkeit der Bone Splitting und Spreading Techniken
- Horizontal Spreader für das sanfte Aufweiten des Kieferkamms um bis zu 5 mm
- Nicht-schneidende Archimedes-Schrauben für sanfte Knochenverdichtung
- Vorbereitung des Knochens für das Inserieren aller gängigen Implantatsysteme

## AT A GLANCE

- Combined System of Crest- and Split-Control
- Possibility of combining bone splitting and spreading techniques
- Horizontal spreaders for gentle widening of the alveolar ridge by up to 5 mm
- Non-cutting Archimedes screws for gentle bone condensing
- Preparation of the bone for insertion of all common implant systems



# Split-Control Professional

Bone Condensing and Bone Spreading System | used by Dr. Dr. Martin Bonsmann

Split-Control Professional ist ein System zur sanften Verbreiterung des Alveolarkamms und gleichzeitiger lateraler Knochenverdichtung bei horizontalem Knochendefizit. Mit Hilfe spezieller schraubenförmiger Verdichtungs- und Spreizinstrumente (Spreader) kann horizontal resorbierter Knochen kontrolliert und sanft aufgedehnt werden (Bone Spreading). Zusätzlich wird dabei spongöser Knochen dank der speziellen Geometrie der Spreader verdichtet (Bone Condensing) und so die Primärstabilität der inserierten Implantate erhöht.

Um noch gezielter auf die spezifischen Indikationen eingehen zu können, enthält das Split-Control Professional eine besonders breite Auswahl an Spreader-Größen.

Split-Control Professional is a system for gentle widening of the alveolar ridge and simultaneous lateral bone condensing in the case of a horizontal bone deficit. With the aid of screw-like condensing and spreading instruments (Spreaders), it is possible to achieve a controlled and gentle dilatation of horizontally resorbed bone (Bone Spreading). Further, cancellous bone is condensed due to the special geometry of the spreaders (Bone Condensing), so that the primary stability of the inserted implants is increased.

To be able to respond more precisely in specific indications, the Split-Control Professional contains a broad range of spreader sizes.



Art.-No. BSPPR

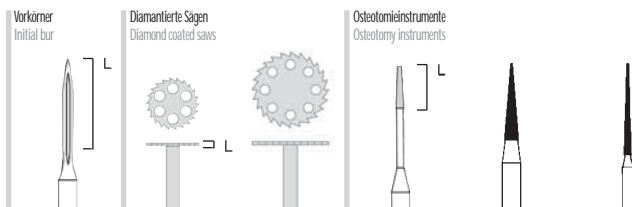

Fig.	186RF	231DC*	231DC*	HM33IL**	859*	859L*
Shank <sup>1</sup>	204	204	204	205	204	204
Size <sup>2</sup>	018	070	100	010	018	010
Length mm	12.0	0.3	0.3	5.5	10.0	12.0
	-	-	-	-	-	-
*	1.8	7.0	10.0	1.0	1.8	1.0

<sup>1</sup> 204=RA, 205=RA L    <sup>2</sup> Größter Arbeitsteildurchmesser in 1/10 mm<sup>2</sup> Largest working part diameter in 1/10 mm  
 Minimaldurchmesser Minimal diameter    \* Außendurchmesser External diameter    \*\*

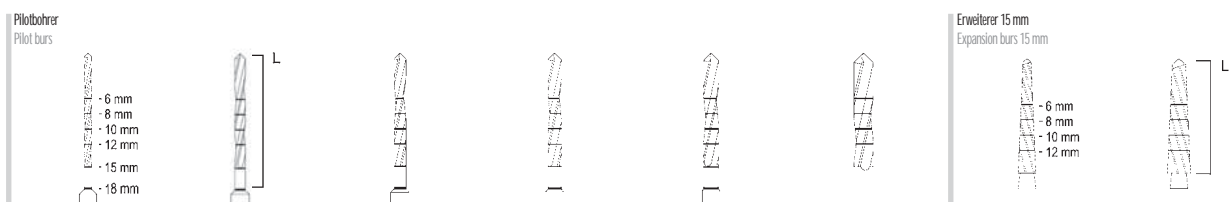

Fig.	A1001	B1001	C1001	D1001	E1001	F1001	A1003	D1003
Shank <sup>1</sup>	206	206	206	206	206	206	206	206
Size <sup>2</sup>	010	013	015	018	020	025	023	030
Length mm	18.0	18.0	18.0	18.0	18.0	15.0	15.0	15.0
	-	-	-	-	-	-	1.03	1.75
*	1.0	1.3	1.5	1.8	2.0	2.5	2.3	3.0

<sup>1</sup> 206=RA XL    <sup>2</sup> Größter Arbeitsteildurchmesser in 1/10 mm<sup>2</sup> Largest working part diameter in 1/10 mm  
 Minimaldurchmesser Minimal diameter    \* Außendurchmesser External diameter



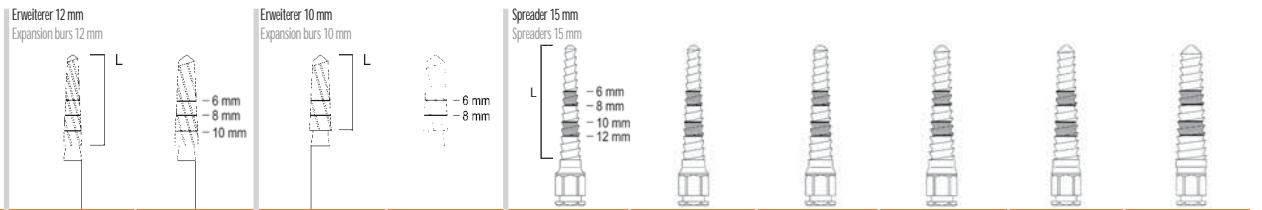

Fig.	A2003	D2003	C3003	E3003	A1005	B1005	C1005	D1005	E1005	F1005
Shank <sup>1</sup>	205	205	205	205	-	-	-	-	-	-
Size <sup>2</sup>	023	030	028	032	027	029	031	033	035	040
Length mm	12.0	12.0	10.0	10.0	15.0	15.0	15.0	15.0	15.0	15.0
▲	1.30	2.03	2.00	2.42	1.43	1.64	1.84	2.05	2.26	2.79
□	2.3	3.0	2.8	3.2	2.7	2.9	3.1	3.3	3.5	4.0

<sup>1</sup> 205=RA L

<sup>2</sup> Größter Arbeitsteildurchmesser in 1/10 mm<sup>2</sup> Largest working part diameter in 1/10 mm

▲ Minimaldurchmesser Minimal diameter

□ Außendurchmesser External diameter

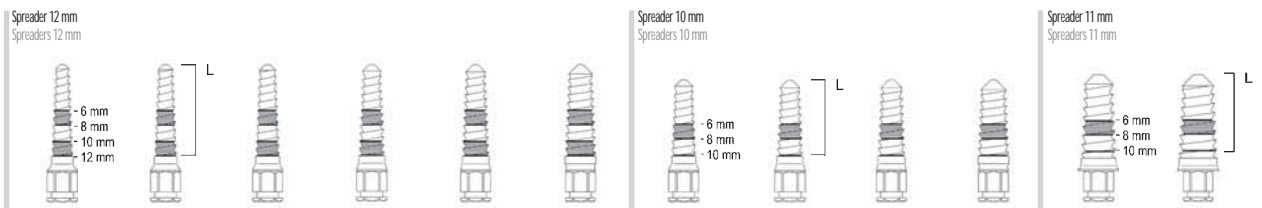

Fig.	A2005	B2005	C2005	D2005	E2005	F2005	C3005	D3005	E3005	F3005	G2005	H2005
Shank <sup>1</sup>	-	-	-	-	-	-	-	-	-	-	-	-
Size <sup>2</sup>	027	029	031	033	035	040	031	033	035	040	045	050
Length mm	12.0	12.0	12.0	12.0	12.0	12.0	10.0	10.0	10.0	10.0	11.0	11.0
▲	1.70	1.91	2.12	2.33	2.54	3.06	2.30	2.51	2.72	3.24	3.65	4.17
□	2.7	2.9	3.1	3.3	3.5	4.0	3.1	3.3	3.5	4.0	4.5	5.0

<sup>2</sup> Größter Arbeitsteildurchmesser in 1/10 mm<sup>2</sup> Largest working part diameter in 1/10 mm

▲ Minimaldurchmesser Minimal diameter

□ Außendurchmesser External diameter



Fig.	CA1RB	CA0RB	CA8RA	CA9RA	CARA4
Shank <sup>1</sup>	-	-	204	205	-
Size <sup>2</sup>	-	-	-	-	-
Length mm	18.0	25.0	24.0	29.0	84.0
▲	-	-	-	-	-
□	-	-	-	-	-

<sup>1</sup> 204=RA, 205=RA L

<sup>2</sup> Größter Arbeitsteildurchmesser in 1/10 mm<sup>2</sup> Largest working part diameter in 1/10 mm

▲ Minimaldurchmesser Minimal diameter

□ Außendurchmesser External diameter

Used by:  
**Dr. Dr. Martin Bonsmann**  
 Düsseldorf, Germany



# HACIS

USA

MEISINGER'S

11<sup>th</sup> Annual High Altitude Comprehensive Implant Symposium



MORE INFORMATION



19.01 - 23.01

2022

*Meisinger*

Zürs / Lesch AUSTRIA

Vail, Colorado USA



REGISTER NOW:

~~2,200 \$~~

[www.meisinger.de](http://www.meisinger.de)

EARLY BIRD RATE  
**2.100 \$**

Valid until 30.11.2021



REGISTER NOW:

~~1,995 \$~~

[www.meisinger.de](http://www.meisinger.de)

EARLY BIRD RATE  
**1.895 \$**

Valid until 30.11.2021



REGISTER NOW:

~~1,795 \$~~

[www.meisinger.de](http://www.meisinger.de)

EARLY BIRD RATE  
**1.695 \$**

Valid until 30.11.2021

## 2022 MASTER OF CEREMONY



Dan Cullum, DDS

## HACIS 2022 SPEAKER LINEUP



Tarun Agarwal, DDS



Michael Block, DMD



Christine Cole, DDS, MHS



Robert Gellin, DMD, MHS



Luiz Gonzaga, DDS, MS



Giles Horrocks, DDS, MS



Jedediah Huss, DDS, DICOI



Dwayne Karateew, DDS



Philip L. Keeve, DDS, MSc



Robert Pauley, DMD



John Russo, DDS, MHS



Mitra Sadrameli, DMD, MS



# BONE MANAGEMENT® MASTER-LINE



Developed by  
Prof. Istvan Urban, DMD, MD, PHD

Systeme für einen ganzheitlichen Workflow von der Gewinnung autologen Knochenmaterials bis hin zur Versorgung mehrdimensionaler Augmentationen  
Systems for a holistic workflow from the extraction of autologous bone material to the treatment of multi-dimensional augmentations





## Master-Core

Innovatives Trepan-System für die kontrollierte Gewinnung von Knochenzylindern mit automatischem Tiefenstopp  
 Innovative Trephine System for controlled extraction of bone cylinders with automatic depth stop

## Master-Mill

Chirurgische Knochenmühle für die zuverlässige Zerkleinerung autologer Knochenblöcke  
 Surgical Bone Mill for the reliable crushing of autologous bone blocks

## Master-Pin

Einzigtiges Pin-System für die sichere Fixation von Membranen  
 Unique Pin System for safe membrane fixation



# BONE MANAGEMENT® COMPETENCE CENTER

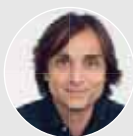

Hungary, Budapest  
**Dr. Istvan Urban DMD, MD, PHD**  
 URBAN REGENERATION INSTITUTE  
 Urbán Dental Center Kft.  
 1025 Budapest  
 Pitypang utca 7., HUNGARY  
[www.implant.hu](http://www.implant.hu)



France, Paris  
**Dr. Hélène Arnal**  
 CABINET D'IMPLANTOLOGIE  
 VILLIERS  
 100 Avenue de Villiers  
 75017 Paris  
[www.selarl-cabinetdudrarnal.chirurgiens-dentistes.fr](http://www.selarl-cabinetdudrarnal.chirurgiens-dentistes.fr)





# Master-Core Basic NEW

Developed by Prof. Istvan Urban

Das Master-Core Basic dient der einfachen und sicheren Gewinnung von Knochenzylindern im Rahmen der Knochenaugmentation. Dazu enthält das System Trepane mit unterschiedlichen Längen und Durchmessern. Aufgrund der unterschiedlichen Längen verfügen die Trepane dabei über eine automatische Tiefenbegrenzung, was für den Schutz anatomischer Strukturen sorgt und damit eine besonders sichere und kontrollierte Knochenentnahme erlaubt. Darüber hinaus ermöglichen Tiefenmarkierungen an den Arbeitsteilen eine zusätzliche Tiefenkontrolle während der Extraktion. Die schwarze Beschichtung der Trepane erlaubt dabei blendfreies Arbeiten und die optimale Sichtbarkeit der Tiefenmarkierungen.

The Master-Core Basic is used for the simple and safe extraction of bone cylinders in the context of bone augmentation. For this purpose, the system contains trepanes with different lengths and diameters. Due to the different lengths, the trepanes have an automatic depth stop, which ensures the protection of anatomical structures and thus allows for a particularly safe and controlled bone extraction. In addition, depth markings on the trepanes' working parts enable additional depth control during the extraction. The black coating of the trepanes allows for glare-free work and the optimal visibility of the depth markings.



Art.-No. BMCBA

## AUF EINEN BLICK

- Einfache und sichere Gewinnung von Knochenzylindern
- Optimaler Schutz anatomischer Strukturen dank tiefenbegrenzter Trepane
- Tiefenmarkierung an den Trepanen zur zusätzlichen Tiefenkontrolle
- Extraktion von Knochenzylindern unterschiedlicher Durchmesser und Längen
- Schwarze Beschichtung der Trepane für blendfreies Arbeiten

## AT A GLANCE

- Simple and safe extraction of bone cylinders
- Optimal protection of anatomical structures thanks to depth-limited trepanes
- Depth markings on the trepanes for additional depth control
- Extraction of bone cylinders of different diameters and lengths
- Black coating on the trepanes for glare-free work

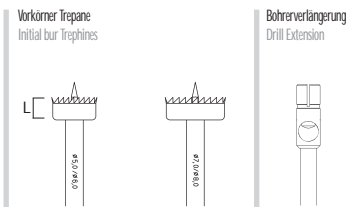

Fig.	DV229	DV229	BV025
Shank <sup>1</sup>	204	204	205
Size <sup>2</sup>	050	070	-
Length mm	2.0	2.0	25.5
□	5.0	7.0	-
* □ *	5.7	7.7	-

<sup>1</sup> 204=RA, 205=RA L

<sup>2</sup> Größter Arbeitsteildurchmesser in 1/10 mm<sup>2</sup> Largest working part diameter in 1/10 mm

□ Innendurchmesser Internal diameter \* □ \* Außendurchmesser External diameter

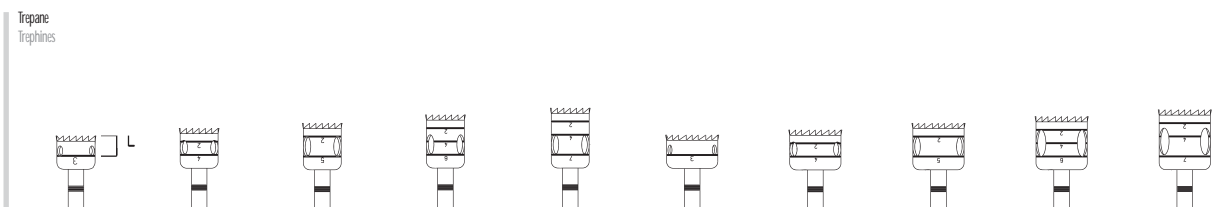

Fig.	229IU	229IU	229IU	229IU	229IU	229IU	229IU	229IU	229IU	229IU
Shank <sup>1</sup>	206	206	206	206	206	206	206	206	206	206
Size <sup>2</sup>	603	604	605	606	607	803	804	805	806	807
Length mm	3.0	4.0	5.0	6.0	7.0	3.0	4.0	5.0	6.0	7.0
□	5.0	5.0	5.0	5.0	5.0	7.0	7.0	7.0	7.0	7.0
* □ *	6.0	6.0	6.0	6.0	6.0	8.0	8.0	8.0	8.0	8.0

<sup>1</sup> 204=RA, 205=RA L

<sup>2</sup> Größter Arbeitsteildurchmesser in 1/10 mm<sup>2</sup> Largest working part diameter in 1/10 mm

□ Innendurchmesser Internal diameter \* □ \* Außendurchmesser External diameter



# Master-Core Professional

**NEW**

Master-Line  
by  
Prof. Istvan Urban

Developed by Prof. Istvan Urban

Das Master-Core Professional dient der einfachen und sicheren Gewinnung von Knochenzylindern im Rahmen der Knochenaugmentation. Dazu enthält das System Trepane mit unterschiedlichen Längen und Durchmessern. Aufgrund der unterschiedlichen Längen verfügen die Trepane dabei über eine automatische Tiefenbegrenzung, was für den Schutz anatomischer Strukturen sorgt und damit eine besonders sichere und kontrollierte Knochenentnahme erlaubt. Darüber hinaus ermöglichen Tiefenmarkierungen an den Arbeitsteilen eine zusätzliche Tiefenkontrolle während der Extraktion. Die schwarze Beschichtung der Trepane erlaubt dabei blendfreies Arbeiten und die optimale Sichtbarkeit der Tiefenmarkierungen. Um besonders gezielt auf spezielle Indikationen eingehen zu können, enthält das Master-Core Professional eine erweiterte Auswahl an Instrumenten.

The Master-Core Professional is used for the simple and safe extraction of bone cylinders in the context of bone augmentation. For this purpose, the system contains trepanes with different lengths and diameters. Due to the different lengths, the trepanes have an automatic depth stop, which ensures the protection of anatomical structures and thus allows for a particularly safe and controlled bone extraction. In addition, depth markings on the trepanes' working parts enable additional depth control during the extraction. The black coating of the trepanes allows for glare-free work and the optimal visibility of the depth markings. To be able to respond more precisely in specific indications, the Master-Core Professional contains a broad range of instruments.



Art.-No. BMCPR

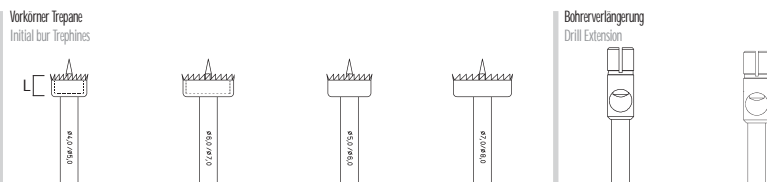

Fig.	DV229	DV229	DV229	DV229	BV024	BV025
Shank <sup>1</sup>	204	204	204	204	205	205
Size <sup>2</sup>	040	050	060	070	-	-
Length mm	2.0	2.0	2.0	2.0	23.5	25.5
□	4.0	5.0	6.0	7.0	-	-
* □ *	4.7	5.7	6.7	7.7	-	-

<sup>1</sup> 204 = RA, 205 = RA L

<sup>2</sup> Größter Arbeitsteildurchmesser in 1/10 mm <sup>2</sup> Largest working part diameter in 1/10 mm □ Innendurchmesser Internal diameter \* □ \* Außendurchmesser External diameter

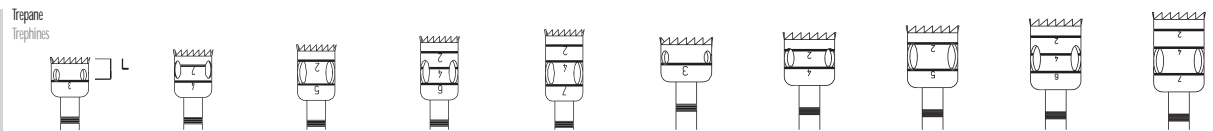

Fig.	229IU	229IU	229IU	229IU	229IU	229IU	229IU	229IU	229IU	229IU
Shank <sup>1</sup>	206	206	206	206	206	206	206	206	206	206
Size <sup>2</sup>	503	504	505	506	507	603	604	605	606	607
Length mm	3.0	4.0	5.0	6.0	7.0	3.0	4.0	5.0	6.0	7.0
□	4.0	4.0	4.0	4.0	4.0	5.0	5.0	5.0	5.0	5.0
* □ *	5.0	5.0	5.0	5.0	5.0	6.0	6.0	6.0	6.0	6.0

<sup>1</sup> 204 = RA, 205 = RA L

<sup>2</sup> Größter Arbeitsteildurchmesser in 1/10 mm <sup>2</sup> Largest working part diameter in 1/10 mm

□ Innendurchmesser Internal diameter \* □ \* Außendurchmesser External diameter

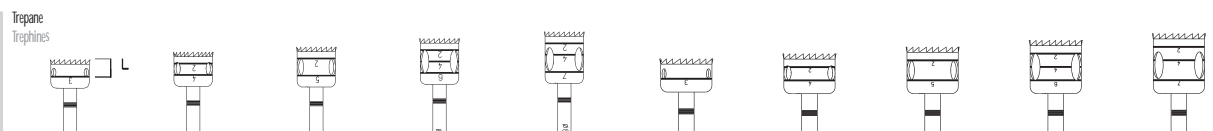

Fig.	229IU	229IU	229IU	229IU	229IU	229IU	229IU	229IU	229IU	229IU
Shank <sup>1</sup>	206	206	206	206	206	206	206	206	206	206
Size <sup>2</sup>	703	704	705	706	707	803	804	805	806	807
Length mm	3.0	4.0	5.0	6.0	7.0	3.0	4.0	5.0	6.0	7.0
□	6.0	6.0	6.0	6.0	6.0	7.0	7.0	7.0	7.0	7.0
* □ *	7.0	7.0	7.0	7.0	7.0	8.0	8.0	8.0	8.0	8.0

<sup>1</sup> 204 = RA, 205 = RA L

<sup>2</sup> Größter Arbeitsteildurchmesser in 1/10 mm <sup>2</sup> Largest working part diameter in 1/10 mm

□ Innendurchmesser Internal diameter \* □ \* Außendurchmesser External diameter



# Master-Mill NEW

## Surgical Bone Mill – used by Prof. Istvan Urban

Die Master-Mill ist eine chirurgische Knochenmühle, die der Zerkleinerung von autologen Knochenblöcken und damit dem Erhalt kleiner autologer Knochenspäne dient. Mit Hilfe dieser Knochenspäne können Knochendefekte aller Formen optimal aufgefüllt werden. Die einzelnen Komponenten der Master-Mill bestehen aus hochwertigem, chirurgischem Edelstahl. Alle Einzelteile verfügen über eine optimale Passung und eine stabile Geometrie, sodass die Master-Mill ein einfaches Handling mit unkompliziertem Zusammenbau und intuitiver Nutzung erlaubt.

The Master-Mill is a surgical bone mill used for crushing autologous bone blocks and thus preserving small autologous bone chips. With the help of these bone chips, bone defects of all shapes can be optimally filled. The individual components of the Master-Mill are made of high quality, surgical stainless steel. All parts feature an optimal fit and a stable geometry, allowing the Master-Mill to be easy to handle with ease of assembly and intuitive use.



Art.-No. BKM00

Master-Mill (inkl. Mahlwerk)  
Master-Mill (incl. Grinder)

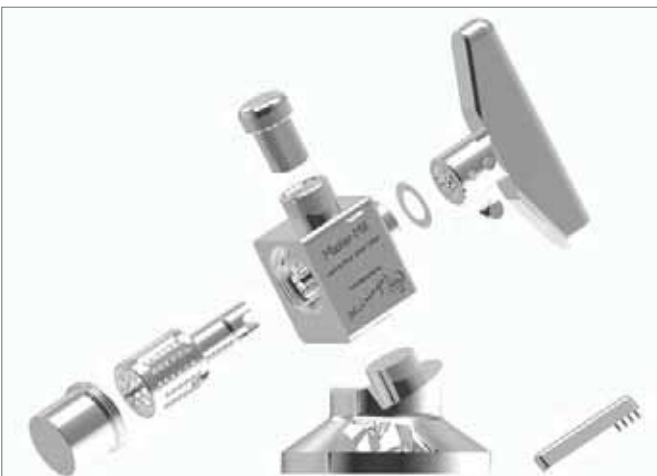

Fig. BKM00

Separates Mahlwerk  
Separate Grinder



BKMMW



© Hager & Melsinger GmbH





## AUF EINEN BLICK

- Zerkleinerung von autologen Knochenblöcken
- Augmentation von Knochendefekten aller Formen
- Einzelteile aus hochwertigem, chirurgischem Edelstahl
- Stabile Geometrie
- Einfaches und intuitives Handling

## AT A GLANCE

- Crushing of autologous bone blocks
- Augmentation of bone defects of all shapes
- Individual components made of high quality, surgical stainless steel
- Stable geometry
- Easy and intuitive handling



# Master-Pin-Control Basic

Pin System for Membrane Fixation | developed with Dr. Istvan Urban



Master-Pin-Control ist speziell für die Fixation resorbierbarer, nicht-resorbierbarer und titanverstärkter Membranen entwickelt worden. Die enthaltenen Pins bestehen aus Titanlegierung Grade 5 und verfügen über eine umlaufende Nut, die die Oberfläche der Pins vergrößert. Dank der umlaufenden Nut und eines einzigartigen Kopf-Designs lassen sich die Pins sicher und leicht lösen, was gerade nach einer erfolgreichen Einheilungszeit von besonderer Bedeutung ist. Mit ihrer scharfen Spitze und dem sehr stabilen Schaft lassen sie sich einfach und präzise in den kortikalen Knochen einbringen.

Master-Pin-Control is designed especially for the fixation of resorbable, non-resorbable and titanium reinforced membranes. The included pins consist of titanium alloy Grade 5 and have a groove which increases the surface of the pins. Due to the groove and a unique head design, the pins can be loosened easily and safely which is especially important after a successful healing period. With their sharp tip and very stable shank, they can easily and precisely be inserted into dense cortical bone.



Art.-No. BMPBA

10x Pins



© Dr. Istvan Urban

## AUF EINEN BLICK

- Ohne Biegen und Brechen - Sichere Fixierung von Membranen mit Pins aus Titanlegierung Grade 5
- Scharfe Spitze und hohe Festigkeit der Pins ermöglichen die präzise Platzierung der Pins auch in kortikalem Knochen und unter einem Einschlagwinkel
- Einfache Entnahme aus dem Tray und Platzierung der Pins mittels speziell entwickeltem Pin-Halter
- Instrumente zum Setzen von Bleeding Points für optimale Einheilungsvoraussetzungen

## AT A GLANCE

- No bending, no breakage - Safe Fixation of Membranes with Pins made of Titanium Alloy Grade 5
- Sharp tip and high stability of the pins allow for precise placement of the pins also in cortical bone and at an angle
- Easy Removal from the tray and placement of the pins due to the specially developed Pin-Holder
- Instruments for the placement of Bleeding Points for optimal healing conditions

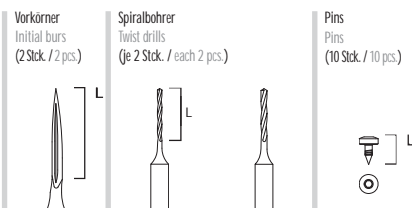

Fig.	186RF	203RF	203RF	MP10*
Shank <sup>1</sup>	204	205	205	-
Size <sup>2</sup>	018	006	008	-
Length mm	12.0	7.0	7.0	3.65
Minimal diameter	-	-	-	0.87
External diameter	1.8	0.6	0.8	0.95
Head-Ø mm	-	-	-	2.51

<sup>1</sup> 204 = RA, 205 = RA L

<sup>2</sup> Größter Arbeitsteildurchmesser in 1/10 mm <sup>2</sup> Largest working part diameter in 1/10 mm

Minimal diameter External diameter



### Nachfüll-Pins / Refill Pins :

Pins à 10 (MP10\*)

Pins à 50 (MP50\*)

Pins à 100 (MP100\*)

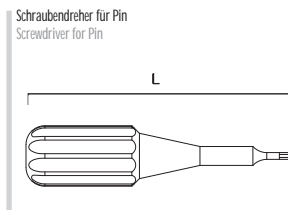

Fig. MP11  
illustrated 1:1 (Lenght mm: 35.0)



Fig. MP12  
illustrated 1:2 (Lenght mm: 170.0)



Fig. MP14  
illustrated 1:2 (Lenght mm: 165.0)



# Master-Pin-Control

Pin System for Membrane Fixation | developed with Dr. Istvan Urban



Master-Pin-Control ist speziell für die Fixation resorbierbarer, nicht-resorbierbarer und titanverstärkter Membranen entwickelt worden. Die enthaltenen Pins bestehen aus Titanlegierung Grade 5 und verfügen über eine umlaufende Nut, die die Oberfläche der Pins vergrößert. Dank der umlaufenden Nut und eines einzigartigen Kopf-Designs lassen sich die Pins sicher und leicht lösen, was gerade nach einer erfolgreichen Einheilungszeit von besonderer Bedeutung ist. Mit ihrer scharfen Spitze und dem sehr stabilen Schaft lassen sie sich einfach und präzise in den kortikalen Knochen einbringen.

Master-Pin-Control is designed especially for the fixation of resorbable, non-resorbable and titanium reinforced membranes. The included pins consist of titanium alloy Grade 5 and have a groove which increases the surface of the pins. Due to the groove and a unique head design, the pins can be loosened easily and safely which is especially important after a successful healing period. With their sharp tip and very stable shank, they can easily and precisely be inserted into dense cortical bone.



Art.-No. BMP00

35x Pins



© Dr. Istvan Urban

Fig.	186RF	203RF	203RF	MP10*
Shank <sup>1</sup>	204	205	205	-
Size <sup>2</sup>	018	006	008	-
Length mm	12.0	7.0	7.0	3.65
Minimal diameter	-	-	-	0.87
External diameter	1.8	0.6	0.8	0.95
Head-Ø mm	-	-	-	2.51

<sup>1</sup> 204 = RA, 205 = RA L  
<sup>2</sup> Größter Arbeitsteildurchmesser in 1/10 mm<sup>2</sup> Largest working part diameter in 1/10 mm  
 Minimal diameter    Außendurchmesser External diameter



**Nachfüll-Pins / Refill Pins :**

- Pins à 10 (MP10\*)
- Pins à 50 (MP50\*)
- Pins à 100 (MP100\*)

Schraubendreher für Pin  
Screwdriver for Pin

Fig. **MP11**  
illustrated 1:1 (Lenght mm: 35.0)

Pin-Halter  
Pin holder

Fig. **MP12**  
illustrated 1:2 (Lenght mm: 170.0)

Fixierhalter  
Fixing holder

Fig. **MP14**  
illustrated 1:2 (Lenght mm: 165.0)



# BONE MANAGEMENT® KHOURY-LINE



Developed by  
Prof. Dr. Fouad Khoury

Ganzheitliche Systemzusammenstellung für die Entnahme, Fixierung und Stabilisierung kortikaler Knochentransplantate nach Prof. Dr. Khoury - optimal ergänzt durch ausgewählte Handinstrumente Sortimente zur Bearbeitung von Hart- und Weichgewebe

Holistic system composition for the extraction, fixation and stabilization of cortical bone grafts according to Prof. Dr. Khoury - optimally complemented by selected manual instrument assortments for treatment of hard and soft tissue





## Trephine Ejection Kit

Trepansystem zur Gewinnung zylindrischer Knochentransplantate  
Trephine System for Extraction of Cylindrical Bone Grafts

## Micro Screw System

Knochenschrauben-System zur sicheren Fixierung und Stabilisierung von kortikalen Knochenblöcken  
Bone Screw System for safe fixation and stabilization of cortical bone blocks

## Ost-Tray

Auswahl manueller Instrumente für die Oralchirurgie  
Selection of Manual Instruments for Oral Surgery

## Sinus-Tray

Auswahl manueller Instrumente für den externen Sinuslift  
Selection of Manual Instruments for external Sinus Lift

## Soft-Tissue-Tray

Auswahl manueller Instrumente für das Weichgewebsmanagement  
Selection of Manual Instruments for Soft-Tissue Management



# BONE MANAGEMENT® COMPETENCE CENTER



Olsberg, Germany

**Prof. Dr. Fouad Khoury**

Privatzahnklinik Schloss Schellenstein GmbH  
Am Schellenstein 1  
59939 Olsberg  
www.implantologieklinik.de



Privatzahnklinik  
Schloss Schellenstein GmbH  
Internationales Zentrum für Implantologie und  
zahnärztliche Chirurgie



Dr. Philip L. Keeve, M.Sc., | Hannover, Germany



Dr. Christopher Schmid MBA MSc. | Bad Homburg, Germany



Dr. Alexander Zastera MSc. | Olsberg, Germany



Dr. Romain Doliveux | Freiburg, Germany



Dr. Michael Berthold | München, Germany



# Trephine Ejection Kit

Trephine System for Extraction of Cylindrical Bone Grafts | developed by Prof. Dr. Fouad Khoury

Das Trephine Ejection Kit, das zusammen mit Prof. Dr. Fouad Khoury entwickelt wurde, vereint gleich mehrere einzigartige Ideen, die das Set zu etwas ganz Besonderem machen: Zweiteilige, innengekühlte Trepane ermöglichen eine sichere und minimalinvasive Entnahme von lokalen Knochenzylindern. Die Innenkühlung hilft dabei zuverlässig eine Schädigung des Knochengewebes durch Überhitzung zu verhindern, während die abnehmbaren Trepan-Arbeitsteile eine besonders einfache Entnahme der herausgefrästen Knochenzylinder erlauben. Die Knochenzylinder können entweder mit Hilfe der Ausstoßnadel oder mit den speziell auf die Durchmesser der Trepane abgestimmten Ausstoßinstrumenten entnommen werden. Zusätzlich ermöglichen die darüber hinaus im Set enthaltenen Vorkörner eine sichere Anwendung der Trepane. Dank der zweiteiligen Trepane, der Auswahl an verschiedenen Durchmessern und der optimalen Abstimmung der Instrumente, bietet das Trephine Ejection Kit dem Anwender höchste Effizienz, Flexibilität und Präzision bei der Entnahme von Knochenzylindern.

The Trephine Ejection Kit was developed together with Prof. Dr. Fouad Khoury. It contains several unique ideas which turn this kit into something special: Two-part, internally cooled trephines allow for a safe and minimal invasive extraction of local bone cylinders. The inner cooling helps to prevent a damage of the bone tissue due to overheating, while the removable trephine working parts allow for an especially easy sampling of the cut out bone cylinders. Either with the aid of the ejection needle or the ejection instruments, which perfectly match with the diameter of the trephine working parts, the bone cylinders can be pushed out of the trephines. Furthermore, the included pre-drilling trephines allow for a safe application of the trephines. Due to the two-part trephines, the variety of different diameters and the optimal matching of the instruments, the Trephine Ejection Kit offers highest efficiency, flexibility and precision to the user for the extraction of bone cylinders.

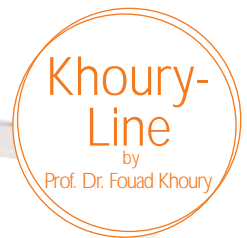

Art.-No. BTE00

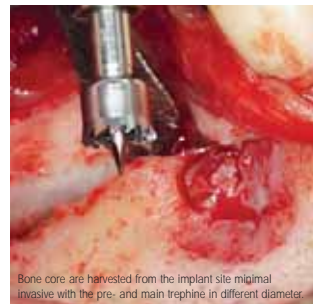

Bone core are harvested from the implant site minimal invasive with the pre- and main trephine in different diameter.



Bone core augmentation stabilized with micro screws

© Prof. Dr. Fouad Khoury

Vorkörner Trepane  
Initial bur trephines

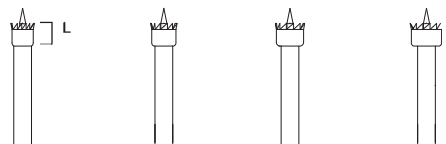

Schaft  
Shank  
(4 Stück / 4 pcs)

Trepane  
Trephines

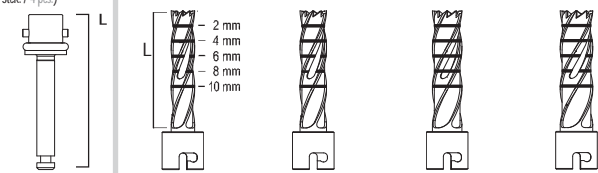
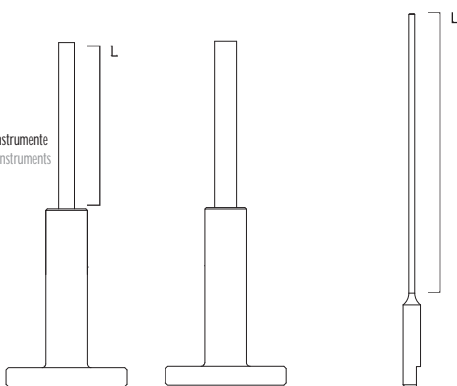

Fig.	230KH	230KH	230KH	230KH	229KH*	229KH	229KH	229KH	229KH
Shank <sup>1</sup>	204	204	204	204	204	900	900	900	900
Size <sup>2</sup>	021	025	029	033	000	021	025	029	033
Length mm	2.0	2.0	2.0	2.0	20.5	15.5	15.5	15.5	15.5
□	2.1	2.5	2.9	3.3	-	2.1	2.5	2.9	3.3
*□*	3.1	3.5	3.9	4.3	-	3.1	3.5	3.9	4.3

<sup>1</sup> 204=RA, 900=Unmounted    <sup>2</sup> Größter Arbeitsteildurchmesser in 1/10 mm    <sup>2</sup> Largest working part diameter in 1/10 mm    □ Innendurchmesser Internal diameter    \*□\* Außendurchmesser External diameter  
<sup>1</sup> 10er Pack Ersatz-O-Ringe unter der Art.-No. 2151 erhältlich. 10-pack replacement O-rings available under Art.-No. 2151.

Ausstoßinstrumente  
Ejection instruments



Ausstoßhülse  
Ejection sleeve

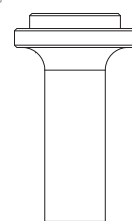

Handrad  
Hand wheel

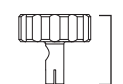

Fig.	ASTKH	ASTKH	ASNKH	ASHKH	HRKH1
Shank <sup>1</sup>	-	-	-	-	-
Size <sup>2</sup>	021	029	008	-	-
Length mm	22.0	22.0	37.0	28.0	15.5
□	-	-	-	5.5	-
*□*	5.5	5.5	-	-	-
△	2.1	2.9	0.8	-	-

<sup>1</sup> 204=RA    <sup>2</sup> Größter Arbeitsteildurchmesser in 1/10 mm    <sup>2</sup> Largest working part diameter in 1/10 mm    △ Minimaldurchmesser Minimal diameter    □ Innendurchmesser Internal diameter    \*□\* Außendurchmesser External diameter



## AUF EINEN BLICK

- Zweiteilige Trepane für die sichere und minimalinvasive Entnahme von Knochenzylindern
- Schutz vor Überhitzung des empfindlichen Knochengewebes durch innengekühlte Trepane
- Innovative Anwendung
- Genormte Durchmesser und präzise Tiefenmarkierungen der Trepane ermöglichen die planbare Entnahme definierter Knochenzylinder
- Exakt aufeinander abgestimmte Instrumente für höchste Präzision und Flexibilität

## AT A GLANCE

- Two-part trephines for a safe and minimal invasive extraction of bone cylinders
- Protection against overheating due to internally cooled trephines
- Innovative application
- Standardized diameters and precise laser markings of the trephines allow for a predictable extraction of defined bone cylinders
- Perfectly matched instruments care for highest precision and flexibility



# Micro Screw System Basic

**NEW**

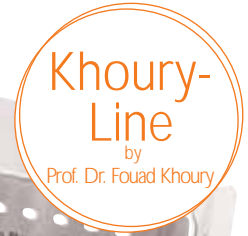

,Olsberger Konzept' by Prof. Dr. Fouad Khoury

Die Bone Management® Micro Screw Systeme dienen der sicheren Fixierung und Stabilisierung von kortikalen Knochentransplantaten. Die Besonderheit dieser Systeme sind die Osteosyntheseschrauben, die über einen Durchmesser von 1,0 mm und 1,2 mm verfügen. Diese Micro Screws bestehen aus einem chirurgischen Edelstahl, der ihnen trotz reduziertem Durchmesser eine hohe Stabilität verleiht.

The Bone Management® Micro Screw Systems are used for the safe fixation and stabilisation of cortical bone grafts. The special feature of these systems are the osteosynthesis screws, which have a diameter of 1.0 mm and 1.2 mm. These Micro Screws are made of surgical stainless steel, which gives them high stability despite their reduced diameter.



Art.-No. BMSBA

Optional erhältlich:  
Optionally available:

**NEW**

## 915DM mittel / medium

Fig.	Schaft / Shank	Ref.-Nr. / Ref.-No.		1
			L mm	0,25
915D	HP	806 <b>104</b> 35M 524		220
	unmounted	806 <b>900</b> 35M 524		220

Super flexibel | Super flexible

	Pilotbohrer Pilot burs	Vorkörner Initial bur	Schraubendreher einfach Screw driver basic	Schraubendreher RA Screw driver RA		
Fig.	MSPB1	MSPB2	202RF	202RF	MSSDE	MSSDW
Shank <sup>1</sup>	204	204	206	206	-	204
Size <sup>2</sup>	008	010	008	010	-	-
Length mm	14.0	14.0	14.0	14.0	100.0	24.0
	-	-	-	-	-	-
	0.8	1.0	0.8	1.0	-	-

<sup>1</sup> 204=RA, 206=RA XL    <sup>2</sup> Größter Arbeitsteildurchmesser in 1/10 mm<sup>2</sup> Largest working part diameter in 1/10 mm

Minimaldurchmesser Minimal diameter    Außendurchmesser External diameter

	Schrauben (je 3 Stück) Screws (each 3 pcs.)	Schrauben (je 3 Stück) Screws (each 3 pcs.)	Schrauben (je 3 Stück) Screws (each 3 pcs.)	Schrauben (je 3 Stück) Screws (each 3 pcs.)	Schrauben (je 3 Stück) Screws (each 3 pcs.)	Schrauben (je 3 Stück) Screws (each 3 pcs.)
Fig.	MSS10 060*	MSS10 080*	MSS10 100*	MSS12 060*	MSS12 080*	MSS12 100*
Shank <sup>1</sup>	-	-	-	-	-	-
Size <sup>2</sup>	-	-	-	-	-	-
Length mm	6.0	8.0	10.0	6.0	8.0	10.0
	0.6	0.6	0.6	0.7	0.7	0.7
	1.0	1.0	1.0	1.2	1.2	1.2
Head-Ø mm	1.7	1.7	1.7	1.7	1.7	1.7

<sup>2</sup> Größter Arbeitsteildurchmesser in 1/10 mm<sup>2</sup> Largest working part diameter in 1/10 mm    Minimaldurchmesser Minimal diameter    Außendurchmesser External diameter







# Micro Screw System NEW

„Olsberger Konzept“ by Prof. Dr. Fouad Khoury

Die Bone Management® Micro Screw Systeme dienen der sicheren Fixierung und Stabilisierung von kortikalen Knochentransplantaten. Die Besonderheit dieser Systeme sind die Osteosyntheseschrauben, die über einen Durchmesser von 1,0 mm und 1,2 mm verfügen. Diese Micro Screws bestehen aus einem chirurgischen Edelstahl, der ihnen trotz reduziertem Durchmesser eine hohe Stabilität verleiht.

The Bone Management® Micro Screw Systems are used for the safe fixation and stabilisation of cortical bone grafts. The special feature of these systems are the osteosynthesis screws, which have a diameter of 1.0 mm and 1.2 mm. These Micro Screws are made of surgical stainless steel, which gives them high stability despite their reduced diameter.



Art.-No. BMS00



Optional erhältlich:  
Optionally available:

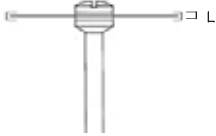

**915DM** mittel / medium



NEW

Fig.	Schaft / Shank	Ref.-Nr. / Ref.-No.		1
			L mm	0,25
915D	HP	806 <b>104</b> 35M 524		220
	unmounted	806 <b>900</b> 35M 524		220



Super flexibel | Super flexible 

Fig.	MSPB1	MSPB2	202RF	202RF	MSSDM	MSGSD	MSSDW
Shank <sup>1</sup>	204	204	206	206	-	-	204
Size <sup>2</sup>	008	010	008	010	-	-	-
Length mm	14.0	14.0	14.0	14.0	142.7	33.0	24.0
	-	-	-	-	-	-	-
	0.8	1.0	0.8	1.0	-	-	-







<sup>1</sup> 204=RA, 206=RA XL    <sup>2</sup> Größter Arbeitsteildurchmesser in 1/10 mm    <sup>2</sup> Largest working part diameter in 1/10 mm  
 Minimaldurchmesser Minimal diameter     Außendurchmesser External diameter

Fig.	MSS10 040*	MSS10 060*	MSS10 080*	MSS10 100*	MSS10 120*	MSS10 140*	MSS12 040*	MSS12 060*	MSS12 080*	MSS12 100*	MSS12 120*	MSS12 140*
Shank <sup>1</sup>	-	-	-	-	-	-	-	-	-	-	-	-
Size <sup>2</sup>	-	-	-	-	-	-	-	-	-	-	-	-
Length mm	4.0	6.0	8.0	10.0	12.0	14.0	4.0	6.0	8.0	10.0	12.0	14.0
	0.6	0.6	0.6	0.6	0.6	0.6	0.7	0.7	0.7	0.7	0.7	0.7
	1.0	1.0	1.0	1.0	1.0	1.0	1.2	1.2	1.2	1.2	1.2	1.2
Head-Ø mm	1.7	1.7	1.7	1.7	1.7	1.7	1.7	1.7	1.7	1.7	1.7	1.7

<sup>2</sup> Größter Arbeitsteildurchmesser in 1/10 mm    <sup>2</sup> Largest working part diameter in 1/10 mm     Minimaldurchmesser Minimal diameter     Außendurchmesser External diameter



# Ost-Tray NEW

Selection of Manual Instruments for Oral Surgery | developed by Prof. Dr. Fouad Khoury

Das Bone Management® Ost-Tray bietet eine perfekte Zusammenstellung aus speziell konfigurierten manuellen chirurgischen Instrumenten. Neben einer durchdachten Auswahl an Handinstrumenten, wie hochwertigen Parodontalsonden, Küretten, Skalpellklingenhaltern, Mundspiegeln, Größenabgestuften Mundkeilen, einer gebogenen Spülkanüle mit Olive sowie diversen Scheren, Nadelhaltern, Pinzetten, Klemmen, Zangen, Wundhaken und Zungenspateln, enthält das Kit insbesondere eine individuell konstruierte, kräftige Khoury-Sonde sowie auf Prof. Khoury abgestimmte Raspatorien und scharfe Löffel.

The Bone Management® Ost-Tray offers a perfect combination of specially configured manual surgical instruments. In addition to a well-thought-out selection of manual instruments, such as high-quality periodontal probes, curettes, scalpel blade holders, mouth mirrors, graduated mouth wedges, a curved irrigation cannula with bulb end and various scissors, needle holders, tweezers, clamps, forceps, retractors and tongue depressors, the kit contains an individually designed, strong Khoury-probe as well as raspatories and sharp spoons according to Prof. Khoury.

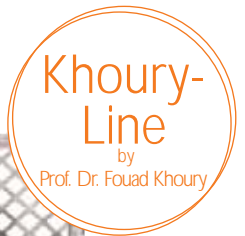

Art.-No. BOST0



Fig.	MI131	MI130
Name	Mundkeil / Mouth wedge	Mundkeil / Mouth wedge
Size	L	XL

**Inklusive:** Spülkanüle mit Olive (Art.-No. MI165)

**Inklusive:** Irrigation Needle with Bulb End (Art.-No. MI165)

Handinstrumente  
Manual Instruments



Fig.	MI056	MI057	MI070	MI071	MI077	MI139	MI156/165	MI160	MI163
Name	Scharfer Löffel 'Khoury', 2,0 mm Bone Curette 'Khoury', 2,0 mm	Scharfer Löffel 'Khoury', 3,0 mm Bone Curette 'Khoury', 3,0 mm	Raspatorium 'Molt' Periosteal Elevator 'Molt'	Raspatorium 'Khoury' Periosteal Elevator 'Khoury'	Skalpellklingenhalter Scalpel Handle	Kürette 'Columbia' Curette 'Columbia'	Mundspiegel Mouth Mirror	Parodontalsonde Periodontal Probe	Sonde, kräftig Probe, strong
Length mm	175.0	175.0	180.0	183.0	152.0	166.0	165.5	160.0	158.0



Handinstrumente  
Manual Instruments

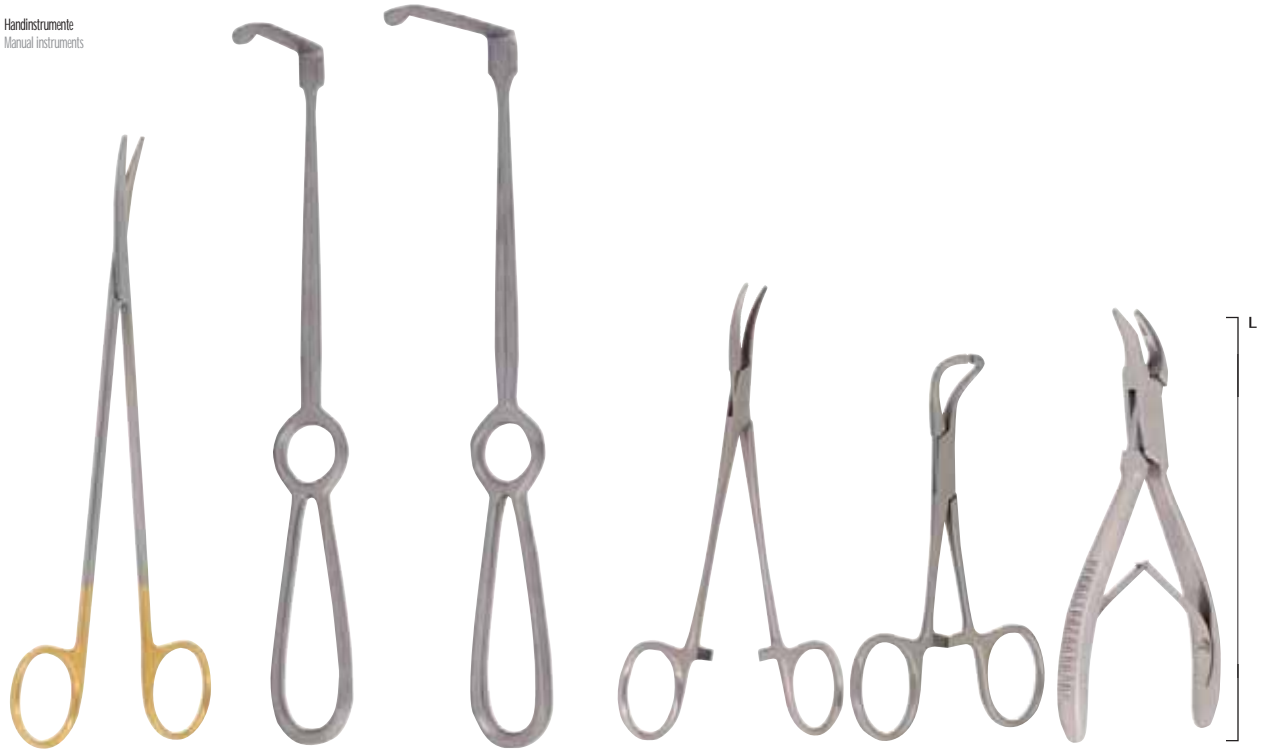

Fig.	MI083	MI101	MI102	MI104	MI105	MI106
Name	Präparierschere 'Metzenbaum', TC Dissecting Scissors 'Metzenbaum', TC	Wundhaken 'Langenbeck' 60x11 mm Tissue Retractor 'Langenbeck' 60x11 mm	Wundhaken 'Langenbeck' 42x10 mm Tissue Retractor 'Langenbeck' 42x10 mm	Arterienklemme 'Halstead-Mosquito' Haemostatic Forceps 'Halstead-Mosquito'	Tuchklemme 'Tohoku' Towel Clip 'Tohoku'	Hohlmeißelzange 'Blumenthal' Bone Rongeur Forceps 'Blumenthal'
Length mm	180.0	220.0	220.0	145.0	105.0	155.0

Handinstrumente  
Manual Instruments



Fig.	MI041	MI048	MI050	MI158	MI089	MI098
Name	Nadelhalter 'Crile Wood', TC Needle Holder 'Crile Wood', TC	Pinzette Tweezers	Pinzette, TC Tweezers, TC	Pinzette 'College' Tweezers 'College'	Chirurgische Schere 'Kelly' Surgical Scissors 'Kelly'	Zungenspatel 'Brüning's' Tongue Depressor 'Brüning's'
Length mm	150.0	175.0	175.0	175.0	160.0	200.0



# Sinus-Tray NEW

Selection of Manual Instruments for external Sinus Lift | developed by Prof. Dr. Fouad Khoury

Das neue Bone Management® Sinus-Tray eignet sich optimal für die Durchführung des externen Sinuslifts. Die mit Prof. Khoury erstellten Handinstrumente unterstützen den Anwender dabei, die Schneidersche Membran schonend abzupräparieren und das Knochenersatzmaterial einzubringen.

The new Bone Management® Sinus-Tray is ideal for performing the external sinus lift. The manual instruments designed with Prof. Khoury support the user in gently lifting the Schneiderian membrane and inserting the bone substitute material.

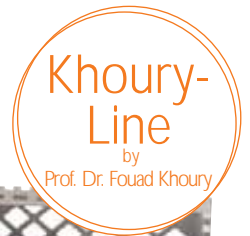

Art.-No. BSINO

**Inklusive:** Spülkanüle mit Olive (Art.-No. MI165)

**Inklusive:** Irrigation Needle with Bulb End (Art.-No. MI165)

Handinstrumente  
Manual Instruments

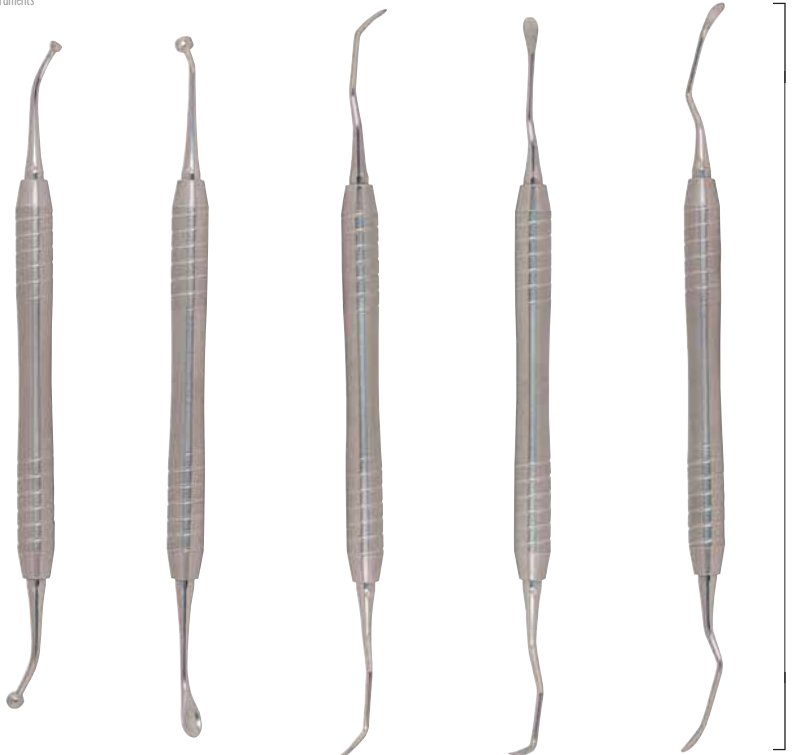
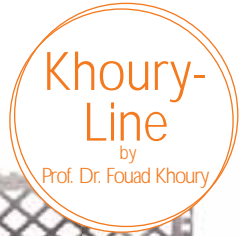

Fig.	MI135	MI136	MI140	MI141	MI142
Name	Kondenser 'Khoury' Condenser 'Khoury'	Knochenmateriallöffel 'Khoury' Bone Material Spoon 'Khoury'	Sinus-Lift Elevator 'Khoury'	Sinus-Lift Elevator 'Khoury'	Sinus-Lift Elevator 'Khoury'
Length mm	168.0	177.0	185.0	190.0	185.0



# Soft-Tissue-Tray NEW

Selection of Manual Instruments for Soft-Tissue Management | developed by Prof. Dr. Fouad Khoury



Das neue Bone Management® Soft-Tissue-Tray wurde in Zusammenarbeit mit Prof. Khoury auf den Workflow im Rahmen der Weichgewebsbearbeitung zugeschnitten. Eine Besonderheit bildet der im Set enthaltene Skalpellklingenhalter mit Schwenkkopf, mit dem der Skalpell-Winkel je nach Bearbeitungsbereich frei eingestellt werden kann. Das vereinfacht das Handling insbesondere bei schwer zugänglichen Bereichen.

The new Bone Management® Soft-Tissue-Tray was developed with Prof. Khoury and is perfectly applicable in the context of soft tissue management. A special feature is the scalpel blade holder with swivel head included in the set, with which the scalpel angle can be freely adjusted depending on the processing area. This simplifies handling, especially in areas that are difficult to access.

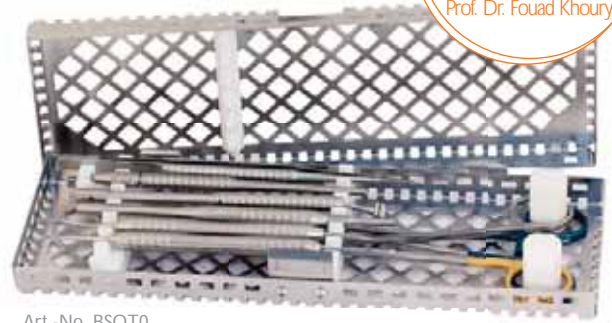

Art.-No. BSOT0

Handinstrumente  
Manual instruments



Fig.	MI042	MI049	MI060	MI077	MI078	MI079	MI089	MI167
Name	Nadelhalter 'Crile Wood', RH Needle Holder 'Crile Wood', RH	Pinzette 'Cooley' Tweezers 'Cooley'	Tunnelierungsinstrument Tunneling Instrument	Skalpell- klingenhalter Scalpel Handle	Skalpell- klingenhalter Scalpel Handle	Skalpell- klingenhalter mit Schwenkkopf Scalpel Handle with Swivel Head	Chirurgische Schere 'Kelly' Surgical Scissors 'Kelly'	Papillenelevator Papilla Elevator
Length mm	150.0	175.0	176.0	173.0	135.0	149.0	160.0	170.0



# SAFESCRAPER® Twist **NEW**

## Ready-To-Use Cortical Bone Collector

Mit dem Safescraper® Twist lassen sich ganz einfach und sicher autologe kortikale Knochenspäne gewinnen. Diese werden während des Einsatzes des Safescrapers® sicher in der transparenten Kammer gesammelt - für eine optimale Kontrolle über die Menge des gewonnenen Knochens. Das gewonnene Knochenmaterial ist dank der sofortigen Mischung mit Blut direkt einsatzfähig und eignet sich zum Auffüllen von Defekten aller Art.

With the Safescraper® Twist, autologous cortical bone chips can be obtained easily and safely. These are safely collected in the transparent chamber while the Safescraper® is in use - for optimal control of the amount of bone harvested. The bone material obtained can be used immediately thanks to the immediate mixture with blood and is suitable for filling up defects of all kinds.

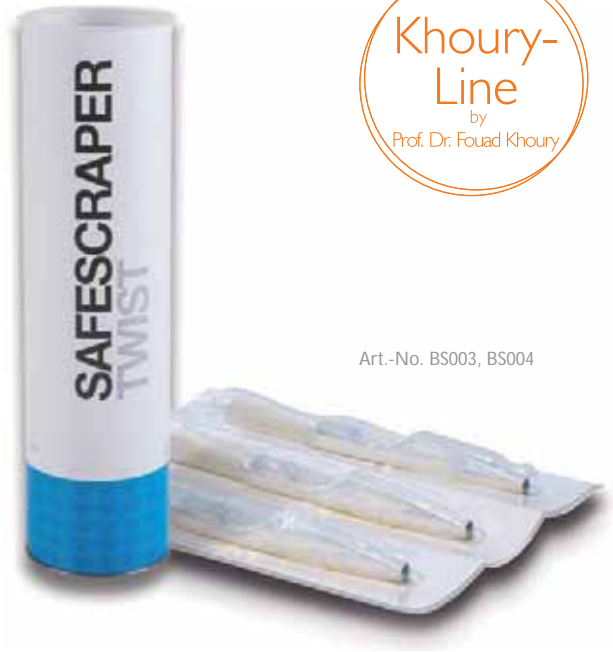
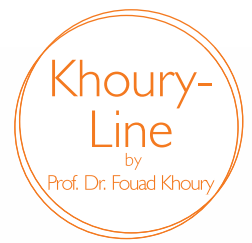

Art.-No. BS003, BS004



Safescraper® TWIST  
gerade Version  
Safescraper® TWIST  
straight Version



Safescraper® TWIST Curve  
abgewinkelte Version  
Safescraper® TWIST Curve  
angled Version



Fig.

BS003

BS004



## AUF EINEN BLICK

- Ready to Use
- Hervorragende Schneidleistung für einen minimalinvasiven und patientenschonenden Eingriff
- Gerade und abgewinkelte Ausführung für jede Situation
- Halbrunde Klinge mit 160° Schneidbereich für höchste Effizienz auf allen Knochenoberflächen
- Aufnahmekapazität der Kammern von 3,0 cm<sup>3</sup> (gerade Ausführung) bzw. 2,5 cm<sup>3</sup> (abgewinkelte Ausführung)
- Sicherheitsmechanismus verhindert ein Öffnen der Kammern während der Knochengewinnung

## AT A GLANCE

- Ready to use
- Excellent cutting performance for a minimally invasive and patient-friendly procedure
- Straight and angled design for every situation
- Half-round blade with 160° cutting area for maximum efficiency on all bone surfaces
- Capacity of the chambers of 3.0 cm<sup>3</sup> (straight version) or 2.5 cm<sup>3</sup> (angled version)
- Safety mechanism prevents the chambers from opening during bone harvesting

# HACIS

EUROPE

MEISINGER'S

12<sup>th</sup> Annual High Altitude Comprehensive Implant Symposium



*Meisinger*

Vail, Colorado USA

Zürs/Lech AUSTRIA

24.01 - 28.01

2023



SAVE  
THE DATE!  
Robinson Club,  
Zürs



Dr. Hélène Arnal



Dr. Valentin Loriod

and many more...



# Transfer-Control Basic

## Horizontal and Vertical Bone Replacing System

Transfer-Control Basic ermöglicht ein passgenaues und genormtes Vorgehen bei der Transplantation von Knochenzylindern zur horizontalen und vertikalen Knochenaugmentation. Die verschiedenen Fräsersysteme sind in drei Durchmessern verfügbar und dabei perfekt aufeinander abgestimmt, sodass die Außendurchmesser der Lagerfräser sowie die Größe der Radfräser den Innendurchmessern der Trepans entsprechen. Hierdurch kann bereits beim Einsetzen des Knochenzylinders eine Klemmpassung erzielt werden, die mit separat erhältlichen Fixationsschrauben (Screw System TX, Art.-No. BTX00 / Screw System TX Professional, Art.-No. BTXPR) verstärkt werden kann. Die passgenau transplantierten Knochenzylinder ergeben durch die schnellere Vitalisierung und Einheilung bereits nach 3-4 Monaten ein transplantationsfähiges Knochenlager.

Transfer-Control Basic ist ein Einstiegssystem mit reduziertem Instrumentarium. Es eignet sich für die Gewinnung von Knochenzylindern der Durchmesser 4,0 mm, 5,0 mm und 6,0 mm.

Transfer-Control Basic permits precise and standardized transplantation of bone cylinders for horizontal and vertical bone augmentation. The instruments are available in three diameters. They are perfectly adapted to each other so that the outer diameter of the abrasive bur and the size of the wheel cutter correlates with the inner diameter of the trephine. So a press fit can be produced between the cylindrical bone and the prepared recipient site. The press fit can then be strengthened with a fixation screw, which is separately available (Screw System TX, Art.-No. BTX00 / Screw System TX Professional, Art.-No. BTXPR). Such precise fitting of bone cylinders lead to accelerated bone revitalization and wound healing. So a transplantable bone site is reached after only 3-4 months.

Transfer-Control Basic is an introductory system with reduced instrument set. It is suitable for the extraction of bone cylinders with diameters of 4.0 mm, 5.0 mm and 6.0 mm.



Anwendungsvideo  
Application Video

Art.-No. CTRBA



© Prof. Milan Jurisic DDS, MSc, PhD

	Diamantlierte Säge Diamond coated saw	Trepans Trephines	Lagerfräser Ablative burs	Radfräser Wheel cutters
Fig.	231DC*	T229L	T229L	TC21X
Shank <sup>1</sup>	204	205	205	205
Size <sup>2</sup>	070	040	050	060
Length mm	0.3	14.0	14.0	14.0
	-	4.0	5.0	6.0
	7.0	5.0	6.0	7.0

	T229L	TC21X	TC084
Shank <sup>1</sup>	205	205	204
Size <sup>2</sup>	050	060	004
Length mm	14.0	14.0	4.0
	5.0	6.0	-
	6.0	7.0	10.0

<sup>1</sup> 204 = RA, 205 = RA L

<sup>2</sup> Größter Arbeitsteildurchmesser in 1/10 mm<sup>2</sup> Largest working part diameter in 1/10 mm

Innendurchmesser Internal diameter

Außendurchmesser External diameter



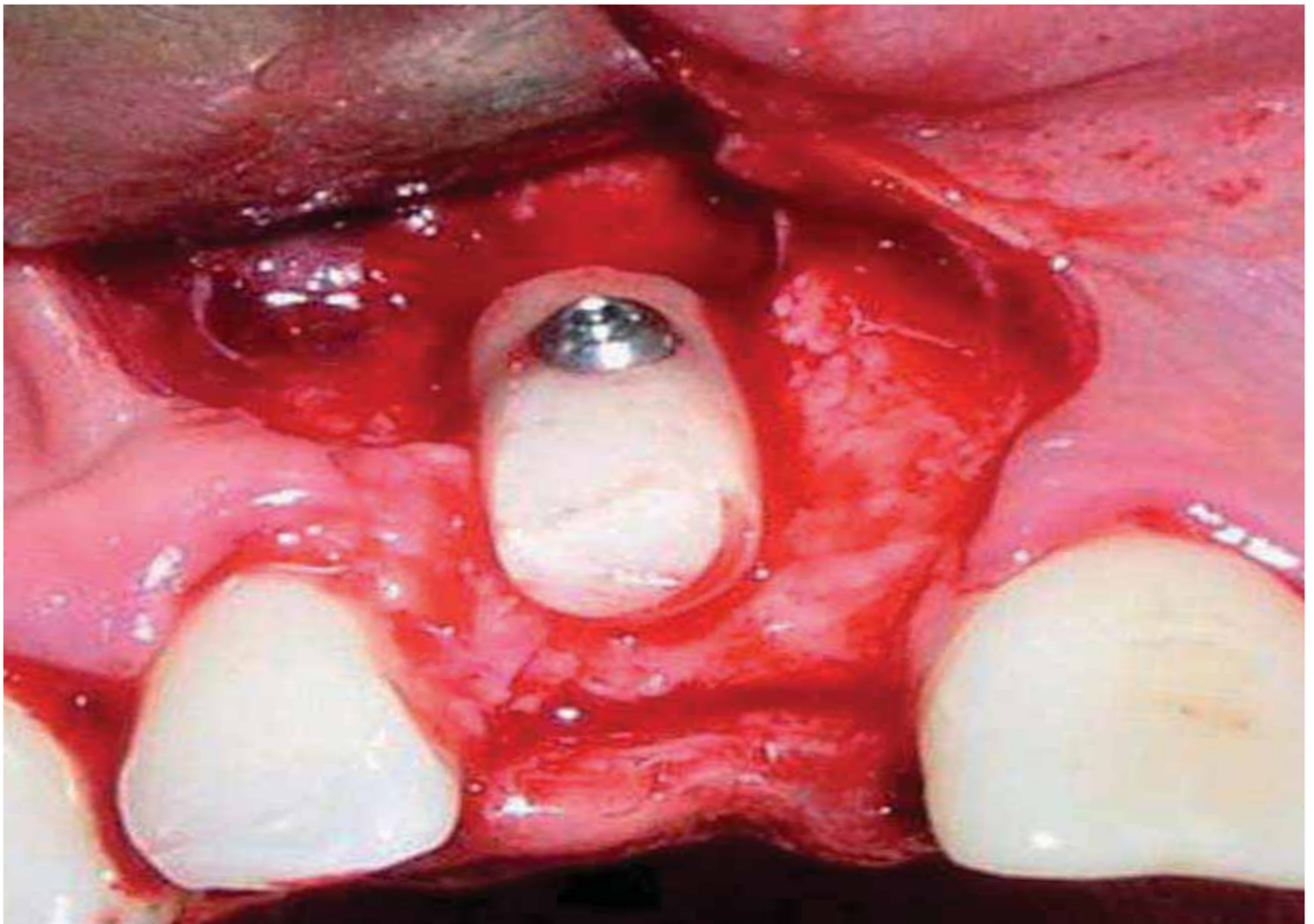

## AUF EINEN BLICK

- Einfaches und sicheres Transplantieren von Knochenzylindern
- Intelligent aufeinander abgestimmte Instrumente
- Passgenaue Knochenzylinder
- Präzises Arbeiten durch Tiefenmarkierung
- Optimal für An- und Auflagerungsplastiken einsetzbar
- Schaffung angefrischter Kontaktflächen für schnelle Vitalisierung und Wundheilung

## AT A GLANCE

- Easy and safe transplantation of bone cylinders
- Intelligently coordinated instruments
- Perfectly fitting bone cylinders
- Precise work due to depth marks
- Optimally suitable for vertical and horizontal augmentations
- Creation of refreshed contact surfaces for rapid vitalization and wound healing



# Transfer-Control

## Horizontal and Vertical Bone Replacing System

Transfer-Control ermöglicht ein passgenaues und genormtes Vorgehen bei der Transplantation von Knochenzylindern zur horizontalen und vertikalen Knochenaugmentation. Die verschiedenen Fräserwerkzeuge sind in fünf Durchmessern verfügbar und dabei perfekt aufeinander abgestimmt, sodass die Außendurchmesser der Lagerfräser sowie die Größe der Radfräser den Innendurchmessern der Trepane entsprechen. Hierdurch kann bereits beim Einsetzen des Knochenzylinders eine Klemmpassung erzielt werden, die mit separat erhältlichen Fixationsschrauben (Screw System TX, Art.-No. BTX00 / Screw System TX Professional, Art.-No. BTXPR) verstärkt werden kann. Die passgenau transplantierten Knochenzylinder ergeben durch die schnellere Vitalisierung und Einheilung bereits nach 3-4 Monaten ein transplantationsfähiges Knochenlager.

Transfer-Control eignet sich für die Gewinnung von Knochenzylindern der Durchmesser 4,0 mm, 5,0 mm, 6,0 mm, 7,0 mm und 8,0 mm.

Transfer-Control permits precise and standardized transplantation of bone cylinders for horizontal and vertical bone augmentation. The instruments are available in five diameters. They are perfectly adapted to each other so that the outer diameter of the ablative bur and the size of the wheel cutter correlates with the inner diameter of the trephine. So a press fit can be produced between the cylindrical bone and the prepared recipient site. The press fit can then be strengthened with a fixation screw, which is separately available (Screw System TX, Art.-No. BTX00 / Screw System TX Professional, Art.-No. BTXPR). Such precise fitting of bone cylinders lead to accelerated bone revitalization and wound healing. So a transplantable bone site is reached after only 3-4 months.

Transfer-Control is suitable for the extraction of bone cylinders with diameters of 4.0 mm, 5.0 mm, 6.0 mm, 7.0 mm and 8.0 mm.



Anwendungsvideo  
Application Video

Art.-No. CTR00



© Dr. Suphachai Suphanguil DDS

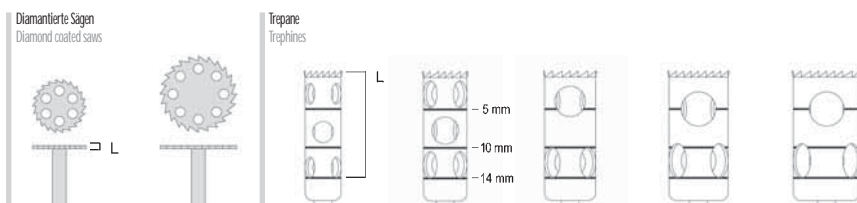

Fig.	231DC <sup>1</sup>	231DC <sup>1</sup>	T229L	T229L	T229L	T229L	T229L
Shank <sup>1</sup>	204	204	205	205	205	205	205
Size <sup>2</sup>	070	100	040	050	060	070	080
Length mm	0.3	0.3	14.0	14.0	14.0	14.0	14.0
	-	-	4.0	5.0	6.0	7.0	8.0
	7.0	10.0	5.0	6.0	7.0	8.0	9.0

<sup>1</sup> 204=RA, 205=RA L    <sup>2</sup> Größter Arbeitsteildurchmesser in 1/10 mm<sup>2</sup> Largest working part diameter in 1/10 mm

Innendurchmesser Internal diameter    Außendurchmesser External diameter

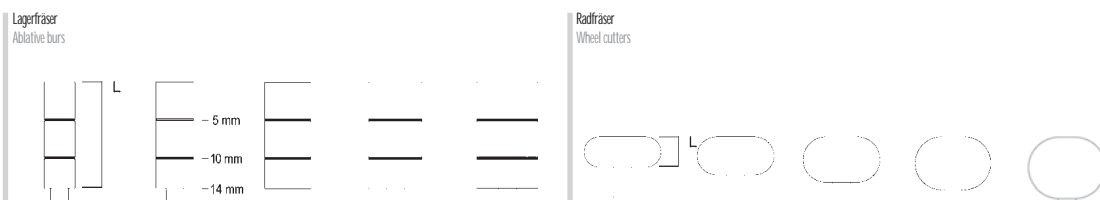
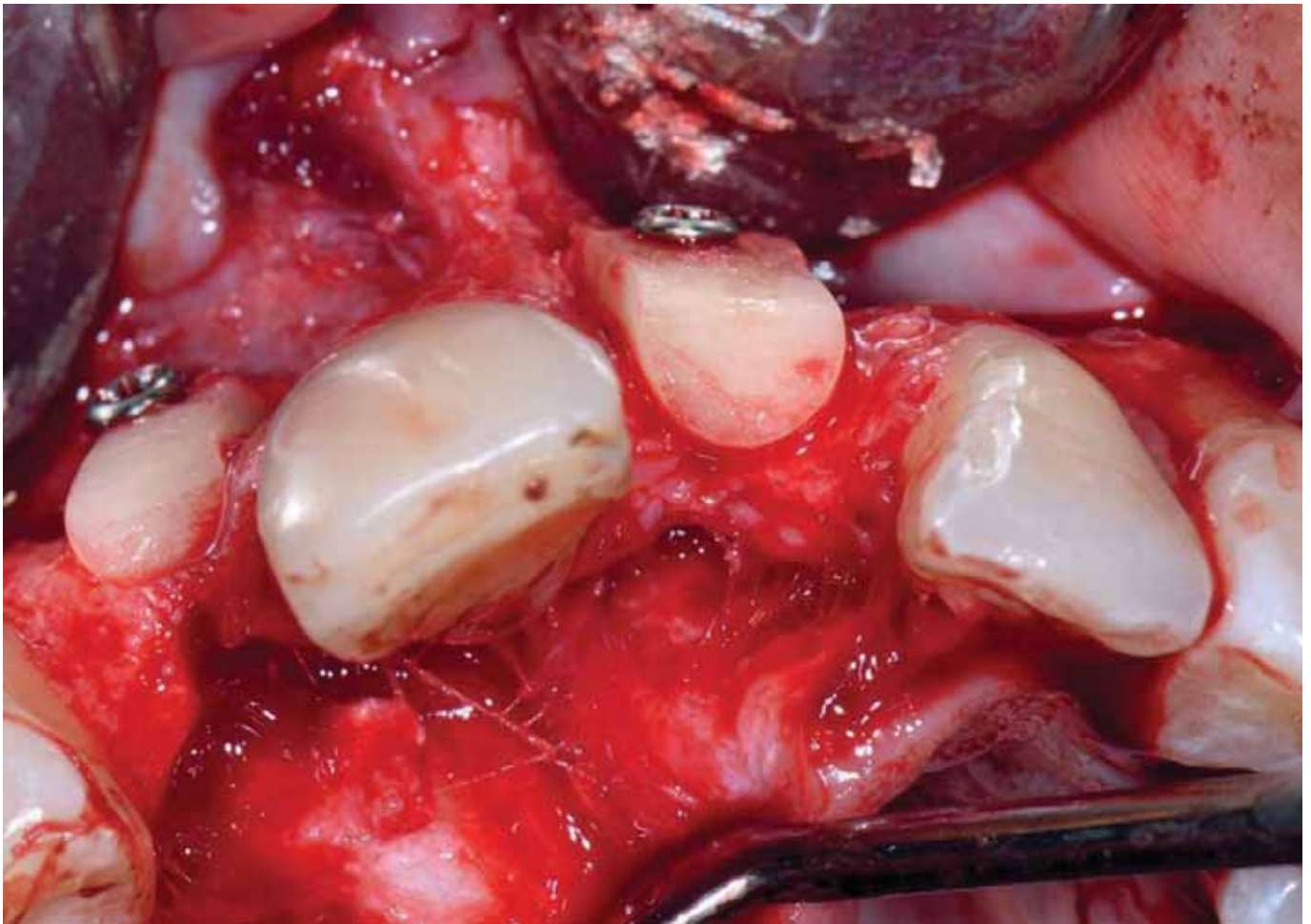

Fig.	TC21X	TC21X	TC21X	TC21X	TC21X	TC084	TC084	TC084	TC084	TC084
Shank <sup>1</sup>	205	205	205	205	205	204	204	204	204	204
Size <sup>2</sup>	040	050	060	070	080	004	005	006	007	008
Length mm	14.0	14.0	14.0	14.0	14.0	4.0	5.0	6.0	7.0	8.0
	-	-	-	-	-	-	-	-	-	-
	4.0	5.0	6.0	7.0	8.0	10.0	10.0	10.0	10.0	10.0

<sup>1</sup> 204=RA, 205=RA L

<sup>2</sup> Größter Arbeitsteildurchmesser in 1/10 mm<sup>2</sup> Largest working part diameter in 1/10 mm

Innendurchmesser Internal diameter    Außendurchmesser External diameter



## AUF EINEN BLICK

- Einfaches und sicheres Transplantieren von Knochenzylindern
- Intelligent aufeinander abgestimmte Instrumente
- Passgenaue Knochenzylinder
- Präzises Arbeiten durch Tiefenmarkierung
- Optimal für An- und Auflagerungsplastiken einsetzbar
- Schaffung angefrischter Kontaktflächen für schnelle Vitalisierung und Wundheilung

## AT A GLANCE

- Easy and safe transplantation of bone cylinders
- Intelligently coordinated instruments
- Perfectly fitting bone cylinders
- Precise work due to depth marks
- Optimally suitable for vertical and horizontal augmentations
- Creation of refreshed contact surfaces for rapid vitalization and wound healing



# Transfer-Ring-Control I

## Vertical Bone Replacing System

Die wichtigste Voraussetzung für die sichere Einheilung eines Knochentransplantates ist ein kongruentes und angefrischtes Empfängerlager. Mithilfe des Transfer-Ring-Control I Systems kann diese Voraussetzung für die Einheilung vertikaler Auflagerungsplastiken einfach und kontrolliert geschaffen werden. Das System bietet eine Vielzahl unterschiedlicher Instrumentengrößen und sorgt so für eine hohe Flexibilität bei der Entnahme von Knochenringen. Je nach Bedarf stehen unterschiedlich große, aufeinander abgestimmte Vorkörner-Trepane, Trepane und Stirnfräser zur Verfügung. Mit Hilfe des zusätzlich enthaltenen Hartmetallbohrers können Knochenkanten präzise geglättet werden.

The most important condition for a safe healing of a bone graft is a congruent and fresh contact surface of the implant area. The Transfer-Ring-Control I System allows for this precondition for the healing of vertical bone grafts in a simple and controlled manner. This system offers a variety of various instrument sizes and provides high flexibility for the extraction of bone rings. Depending on requirements, various sizes of Initial Bur Trephines, Trephines and Ablative Burs are available. With the aid of the additional tungsten carbide bur, sharp bone edges can be smoothed precisely.



Anwendungsvideo  
Application Video

Art.-No. CTRIO

	Vorkörner Initial bur		Vorkörner Trepane Initial bur trephines					Hartmetall Kugelfräser Tungsten carbide round drill
Fig.	186RF	DV229	DV229	DV229	DV229	DV229	DV229	HM141A*
Shank <sup>1</sup>	204	204	204	204	204	204	204	205
Size <sup>2</sup>	018	040	050	060	070	080	035	
Length mm	12.0	2.0	2.0	2.0	2.0	2.0	2.0	-
	-	4.0	5.0	6.0	7.0	8.0	-	-
	1.8	4.7	5.7	6.7	7.7	8.7	3.5	

<sup>1</sup> 204=RA, 205=RA L    <sup>2</sup> Größter Arbeitsteildurchmesser in 1/10 mm    <sup>2</sup> Largest working part diameter in 1/10 mm

Innendurchmesser Internal diameter    Außendurchmesser External diameter

\*

	Trepane Trephines					Lagerfräser Ablative burs				
Fig.	229L	229L	229L	229L	229L	DD207	DD207	DD207	DD207	DD207
Shank <sup>1</sup>	205	205	205	205	205	204	204	204	204	204
Size <sup>2</sup>	040	050	060	070	080	040	050	060	070	080
Length mm	14.0	14.0	14.0	14.0	14.0	3.2	3.2	3.2	3.2	3.2
	4.0	5.0	6.0	7.0	8.0	-	-	-	-	-
	5.0	6.0	7.0	8.0	9.0	4.0	5.0	6.0	7.0	8.0

<sup>1</sup> 204=RA, 205=RA L    <sup>2</sup> Größter Arbeitsteildurchmesser in 1/10 mm    <sup>2</sup> Largest working part diameter in 1/10 mm

Innendurchmesser Internal diameter    Außendurchmesser External diameter



# Transfer-Ring-Control II

## One-Stage Bone Ring Augmentation System | Technology by Dr. Bernd Giesenhagen

Transfer-Ring-Control II ist ein System für die von Dr. Giesenhagen entwickelte Knochenring-Technik. Diese dient dem einzeitigen Vorgehen von Augmentation und Implantation bei resorbiertem Kieferknochen, wenn eine Implantatinsertion alleine aufgrund unzureichender Platzverhältnisse nicht möglich ist. Dank der perfekt aufeinander abgestimmten Instrumente wird an der Implantationsstelle ein kongruentes Knochen- und Implantatlager geschaffen, das die Versorgung dreidimensionaler Defekte mit Hilfe vorfabrizierter, allogener Knochenringe ermöglicht.

Durch die optimale Passung zwischen Kieferknochen, Knochenring und inseriertem Implantat und der Möglichkeit des einzeitigen Vorgehens, wird eine hohe Primärstabilität erreicht und die Behandlungszeit deutlich verkürzt.

Transfer-Ring-Control II is a system for the bone ring technique, developed by Dr. Giesenhagen. It allows for one-stage proceeding of augmentation and implantation in case of resorbed jaw bone, if implant insertion alone is not possible because of inadequate spatial conditions. Due to the perfectly matched instruments, there is created a congruent bone and implant site, which allows for the treatment of three-dimensional defects with the help of prefabricated, allogenic bone rings. Because of the optimal fit between jaw bone, bone ring and inserted implant and the possibility of the one-stage proceeding, high primary stability is accomplished and healing time is significantly reduced.



Art.-No. BBR00

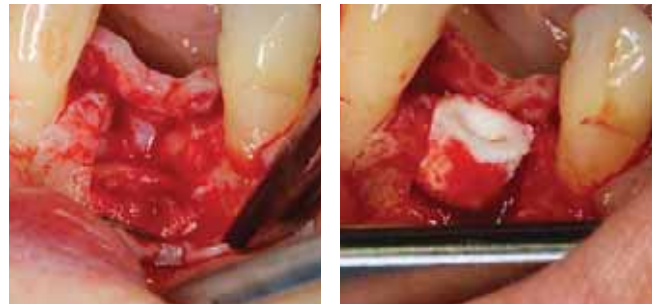

© Dr. Bernd Giesenhagen

Optional erhältlich:  
Optionally available:

Fig.	E1001	HM141A**	231DC*	229FS	229FS	DD207	DD207
Shank <sup>1</sup>	206	206	204	205	205	204	204
Size <sup>2</sup>	020	031	100	060	070	060	070
Length mm	18.0	-	0.3	12.0	12.0	3.2	3.2
	-	-	-	5.0	6.0	-	-
	2.0	3.1	10.0	6.0	7.0	6.0	7.0

<sup>1</sup> 204=RA, 205=RA L, 206=RA XL    <sup>2</sup> Größter Arbeitsteildurchmesser in 1/10 mm<sup>2</sup> Largest working part diameter in 1/10 mm

Innendurchmesser Internal diameter    Außendurchmesser External diameter

**Knochenring Pinzette**  
Bone ring tweezer

illustrated 12



Fig.	BR001
Length mm	166.0

Geignet für die Anwendung in Kombination mit Knochenringen der Durchmesser 6,0 mm und 7,0 mm  
Suitable for use in combination with bone rings with diameters of 6.0 mm and 7.0 mm

Technology by  
**Dr. Bernd Giesenhagen**  
Kassel, Germany



# Transfer-Control Plus

## Combined System for Horizontal and Vertical Bone Augmentation

Transfer-Control Plus ermöglicht ein passgenaues und genormtes Vorgehen bei der Transplantation von Knochenzylindern und -ringen zur horizontalen und vertikalen Knochenaugmentation. Die verschiedenen Fräswerkzeuge sorgen für hohe Flexibilität bei der Entnahme von Knochentransplantaten. Sie sind dabei perfekt aufeinander abgestimmt, wodurch bereits beim Einsetzen der Knochentransplantate eine Klemmpassung erzielt werden kann. Diese kann mit separat erhältlichen Fixationsschrauben (Screw System TX, Art.-No. BTX00 / Screw System TX Professional, Art.-No. BTXPR) noch verstärkt werden. Die passgenau transplantierten Knochenzylinder und -ringe ergeben durch die schnellere Vitalisierung und Einheilung bereits nach 3-4 Monaten ein transplantationsfähiges Knochenlager.

Transfer-Control Plus permits precise and standardized transplantation of bone cylinders and rings for horizontal and vertical bone augmentation. Different types of bone burs allow for high flexibility for the extraction of bone grafts. The instruments are perfectly adapted to each other often producing a press fit between the cylindrical bone or ring and the prepared recipient site. This press fit can then be strengthened with a fixation screw which is sold separately (Screw System TX, Art.-No. BTX00 / Screw System TX Professional, Art.-No. BTXPR). Such precise fitting of bone cylinders lead to accelerated bone revitalization and wound-healing. So a transplantable bone site is reached after only 3-4 months.



Anwendungsvideo  
Application Video

Art.-No. CTRPL

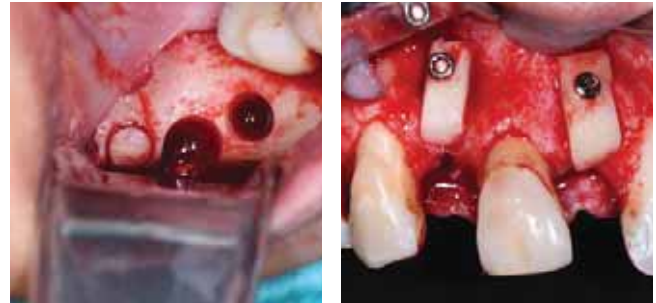

© Dr. Suphachai Suphangul DDS

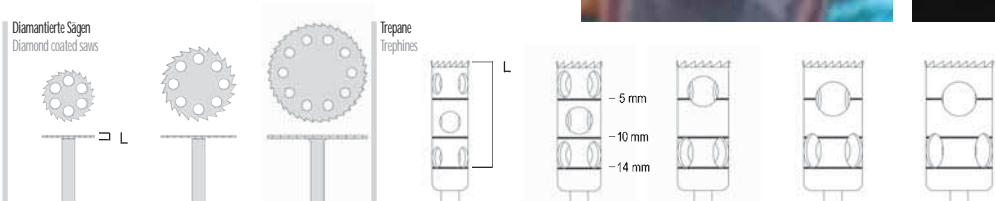

Fig.	231DC*	231DC*	231DC*	T229L	T229L	T229L	T229L	T229L
Shank <sup>1</sup>	204	204	204	205	205	205	205	205
Size <sup>2</sup>	070	100	130	040	050	060	070	080
Length mm	0.3	0.3	0.3	14.0	14.0	14.0	14.0	14.0
	-	-	-	4.0	5.0	6.0	7.0	8.0
	7.0	10.0	13.0	5.0	6.0	7.0	8.0	9.0

<sup>1</sup> 204=RA, 205=RA L    <sup>2</sup> Größter Arbeitsteildurchmesser in 1/10 mm<sup>2</sup> Largest working part diameter in 1/10 mm

Innendurchmesser Internal diameter    Außendurchmesser External diameter

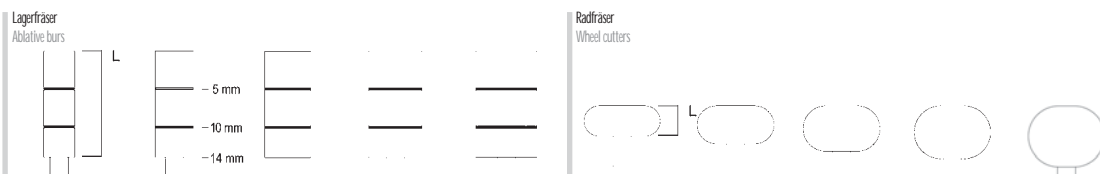

Fig.	TC21X	TC21X	TC21X	TC21X	TC21X	TC084	TC084	TC084	TC084	TC084
Shank <sup>1</sup>	205	205	205	205	205	204	204	204	204	204
Size <sup>2</sup>	040	050	060	070	080	004	005	006	007	008
Length mm	14.0	14.0	14.0	14.0	14.0	4.0	5.0	6.0	7.0	8.0
	-	-	-	-	-	-	-	-	-	-
	4.0	5.0	6.0	7.0	8.0	10.0	10.0	10.0	10.0	10.0

<sup>1</sup> 204=RA, 205=RA L

<sup>2</sup> Größter Arbeitsteildurchmesser in 1/10 mm<sup>2</sup> Largest working part diameter in 1/10 mm

Innendurchmesser Internal diameter    Außendurchmesser External diameter

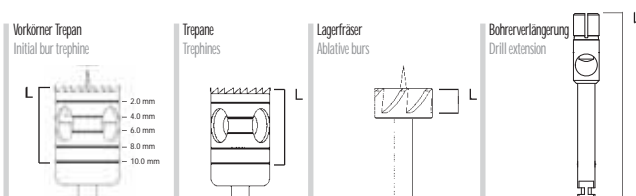

Fig.	229VT	229	207RF	BV025
Shank <sup>1</sup>	205	205	205	205
Size <sup>2</sup>	075	075	075	-
Length mm	10.0	10.0	3.2	25.0
	7.5	7.5	-	-
	8.5	8.5	7.5	-

205=RA L

<sup>2</sup> Größter Arbeitsteildurchmesser in 1/10 mm<sup>2</sup> Largest working part diameter in 1/10 mm

Innendurchmesser Internal diameter    Außendurchmesser External diameter



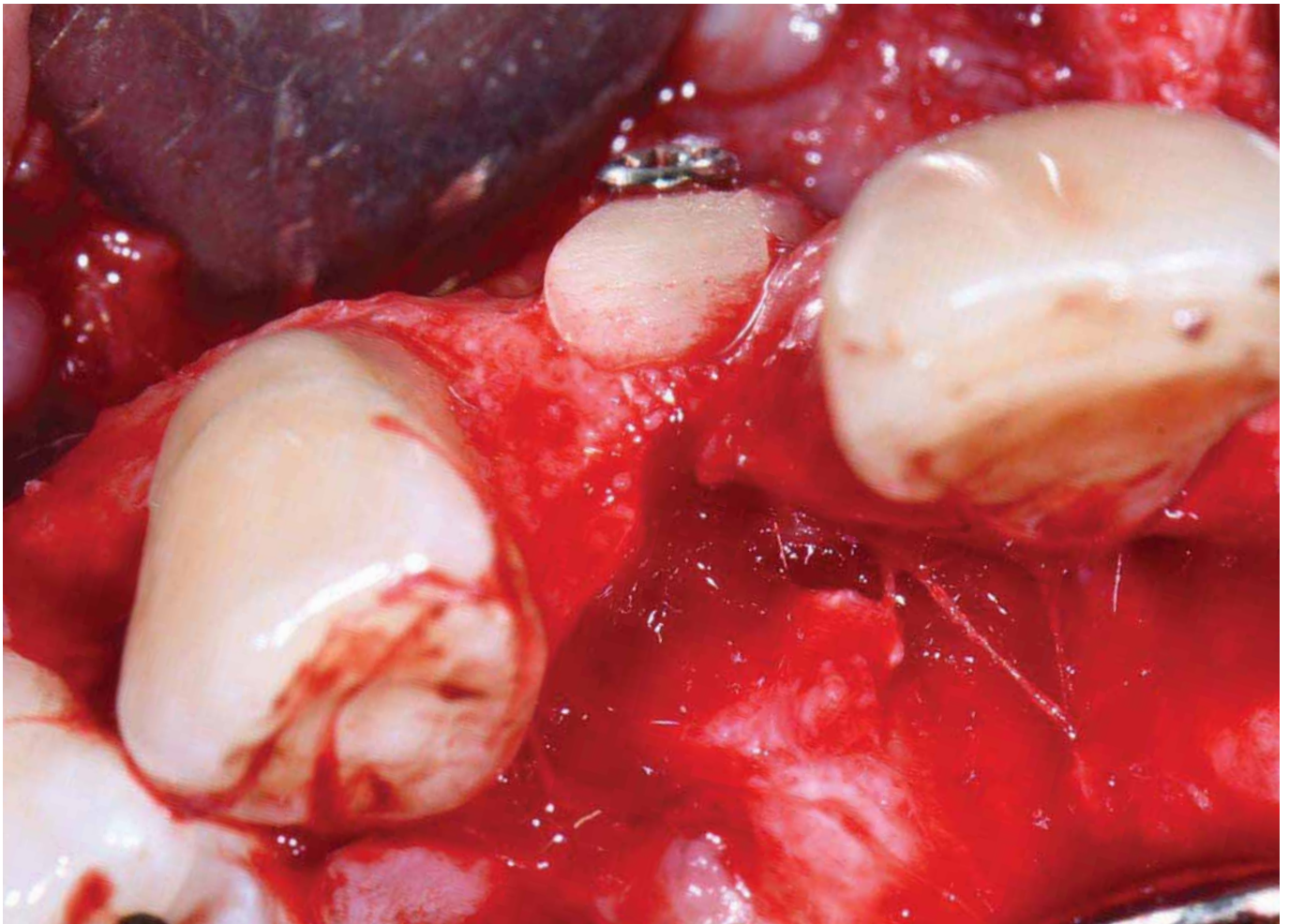

## AUF EINEN BLICK

- Kombiniertes System zum einfachen und sicheren Transplantieren von passgenauen Knochenzylindern und -ringen
- Intelligent aufeinander abgestimmte Instrumente
- Optimal für An- und Auflagerungsplastiken einsetzbar
- Präzises Arbeiten durch Tiefenmarkierung
- Schaffung angefrischter Kontaktflächen für schnelle Vitalisierung und Wundheilung

## AT A GLANCE

- Combined system for easy and safe transplantation of bone cylinders and rings
- Intelligently coordinated instruments
- Optimally suitable for vertical and horizontal augmentations
- Precise work due to depth marks
- Creation of refreshed contact surfaces for rapid vitalization and wound healing



# Screw System TX

## Screw System for Bone Fixation

Das Osteosynthese System Screw System TX ermöglicht einen universellen Einsatz zur Fixierung von autologen Knochenzylindern, Knochenblöcken und Knochenchalen im Rahmen der präimplantologischen Augmentation. Der Torx-Anschluss gewährleistet eine sichere Aufnahme der Schrauben im Eindreherwerkzeug. Gleichzeitig können hohe Zugkräfte übertragen werden. Zu jeder im Kerndurchmesser verfügbaren Schraube von 0,9 mm steht im Set eine im Durchmesser größere Rescue-Schraube zur Verfügung, falls sich das Transplantat nicht zugsicher fixieren lässt. Der geringe Durchmesser sowie die flache Kopfgröße der Schrauben machen den Einsatz besonders komfortabel für Patient und Anwender.

The Osteosynthesis System Screw System TX enables the universal use of fixation for autologous bone cylinders, bone blocks and bone shells for the purpose of preimplantological augmentation. The Torx connection guarantees reliable accommodation of the screws in the driving tool and, at the same time, high tensile forces can be transferred. For each 0.9 mm screw available, the kit contains a larger diameter rescue screw in case the transplant does not allow high tensile fixation. The small diameter and the low head size of the screws allow for a comfortable application for patient and user.



Anwendungsvideo  
Application Video

Art.-No. BTX00

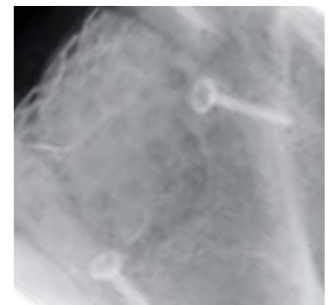

© Hager & Meisinger GmbH, Germany

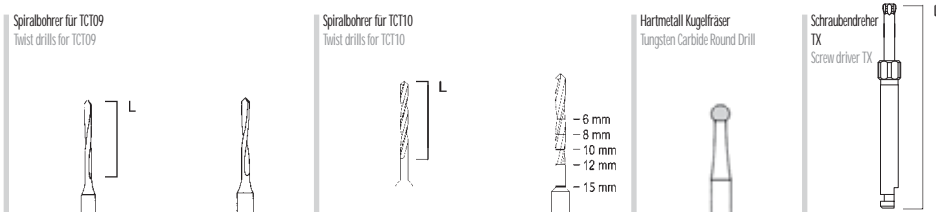

Fig.	203RF	203RF	TC203	A2001	HM141F*	31053
Shank <sup>1</sup>	205	205	204	205	205	205
Size <sup>2</sup>	009	011	010	013	023	-
Length mm	9.0	9.0	12.0	15.0	-	27.0
	-	-	-	-	-	-
	0.9	1.1	1.0	1.3	2.3	-

<sup>1</sup> 204=RA, 205=RA L    <sup>2</sup> Größter Arbeitsteildurchmesser in 1/10 mm    <sup>2</sup> Largest working part diameter in 1/10 mm

Minimaldurchmesser Minimal diameter    Außendurchmesser External diameter



Optional erhältlich:  
Optionally available:



Fig. TL0T1  
Length mm 148.0

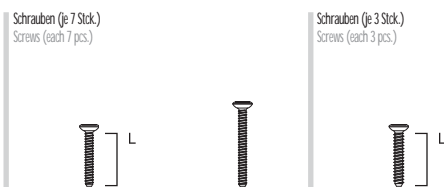

Fig.	TCT09*	TCT09*	TCT10*	TCT10*
Shank <sup>1</sup>	-	-	-	-
Size <sup>2</sup>	-	-	-	-
Length mm	7.0	10.0	7.0	10.0
	0.9	0.9	1.0	1.0
	1.1	1.1	1.3	1.3
Head-Ø mm	2.5	2.5	2.5	2.5

<sup>2</sup> Größter Arbeitsteildurchmesser in 1/10 mm    <sup>2</sup> Largest working part diameter in 1/10 mm    Minimaldurchmesser Minimal diameter

Außendurchmesser External diameter





# Screw System TX Professional

## Screw System for Bone Fixation

Das Osteosynthese System Screw System TX Professional ermöglicht einen universellen Einsatz zur Fixierung von autologen Knochenzylindern, Knochenblöcken und Knochenhäuten im Rahmen der präimplantologischen Augmentation. Der Torx-Anschluss gewährleistet eine sichere Aufnahme der Schrauben im Eindrehwerkzeug. Gleichzeitig können hohe Zugkräfte übertragen werden. Zu jeder im Kerndurchmesser verfügbaren Schraube von 0,9 mm steht im Set eine im Durchmesser größere Rescue-Schraube zur Verfügung, falls sich das Transplantat nicht zugsicher fixieren lässt. Der geringe Durchmesser sowie die flache Kopfgröße der Schrauben machen den Einsatz besonders komfortabel für Patient und Anwender.

Das Screw System TX Professional enthält zusätzlich Schrauben in den Längen 13,0 mm und 16,0 mm.

The Osteosynthesis System Screw System TX Professional enables the universal use of fixation for autologous bone cylinders, bone blocks and bone shells for the purpose of preimplantological augmentation. The Torx connection guarantees reliable accommodation of the screws in the driving tool and, at the same time, high tensile forces can be transferred. For each 0.9 mm screw available, the kit contains a larger diameter rescue screw in case the transplant does not allow high tensile fixation. The small diameter and the low head size of the screws allow for a comfortable application for patient and user.

The Screw System TX Professional contains additional screws in the lengths of 13.0 mm and 16.0 mm.



Anwendungsvideo  
Application Video

Art.-No. BTXPR

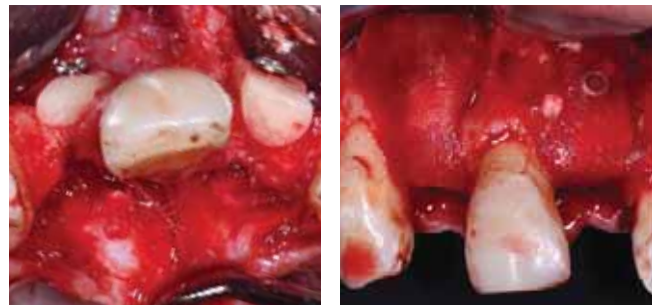

© Dr. Suphachai Suphanguit DDS

Optional erhältlich:  
Optionally available:

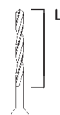

Fig. TL0T1  
Length mm 148.0

Spiralbohrer für TCT09  
Twist drills for TCT09



Spiralbohrer für TCT10  
Twist drills for TCT10



Hartmetall Kugelfräser  
Tungsten Carbide Round Drill

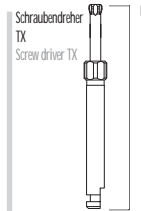

Fig.	203RF	203RF	TC203	A2001	HM141F*	31053
Shank <sup>1</sup>	205	205	204	205	205	205
Size <sup>2</sup>	009	011	010	013	023	-
Length mm	9.0	9.0	12.0	15.0	-	27.0
	-	-	-	-	-	-
	0.9	1.1	1.0	1.3	2.3	-

<sup>1</sup> 204=RA, 205=RA L <sup>2</sup> Größter Arbeitsteildurchmesser in 1/10 mm <sup>3</sup> Largest working part diameter in 1/10 mm

Minimaldurchmesser Minimal diameter Außendurchmesser External diameter



Schrauben (je 7 Stück.)  
Screws (each 7 pcs.)

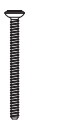

Schrauben (je 3 Stück.)  
Screws (each 3 pcs.)



Fig.	TCT09*	TCT09*	TCT09*	TCT09*	TCT10*	TCT10*	TCT10*	TCT10*
Shank <sup>1</sup>	-	-	-	-	-	-	-	-
Size <sup>2</sup>	-	-	-	-	-	-	-	-
Length mm	7.0	10.0	13.0	16.0	7.0	10.0	13.0	16.0
	0.9	0.9	0.9	0.9	1.0	1.0	1.0	1.0
	1.1	1.1	1.1	1.1	1.3	1.3	1.3	1.3
Head-Ø mm	2.5	2.5	2.5	2.5	2.5	2.5	2.5	2.5

<sup>2</sup> Größter Arbeitsteildurchmesser in 1/10 mm <sup>3</sup> Largest working part diameter in 1/10 mm

Minimaldurchmesser Minimal diameter

Außendurchmesser External diameter





# Trephine Basic Kit

## Trephine System for Extraction of Cylindrical Bone Grafts

Das Trephine Basic Kit bietet ein ausgewähltes Sortiment hochwertiger Trepane verschiedener Größen. Diese sind zum präzisen und einfachen Erstellen von zylindrischen Knochentransplantaten sowie zur Knochenentnahme geeignet. Die Trepane haben eine Tiefe von 10 mm und eignen sich speziell für den Einsatz in der Kieferchirurgie und Implantologie. Dank der gut erkennbaren Tiefenmarkierungen im Abstand von jeweils 2 mm kann beim Einsatz jederzeit leicht und sicher die Frästiefe abgelesen werden.

The Trephine Basic Kit provides a selected set of high-quality trephine drills in different sizes. These tools are designed specifically for creating cylindrical bone grafts quickly and accurately and for removing defined bone sections. The trephine drills have a depth of 10 mm and have been developed specifically with mandibular surgery and implantology in mind. Thanks to the well-defined laser depth marking in 2 mm intervals, the drilling depth can accurately be monitored.



Art.-No. 7120

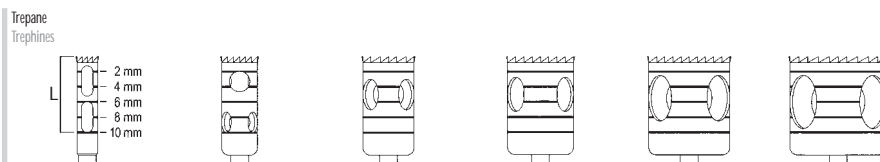



Fig.	229	229	229	229	229	229
Shank <sup>1</sup>	205	205	205	205	205	205
Size <sup>2</sup>	020	040	060	080	100	120
Length mm	10.0	10.0	10.0	10.0	10.0	10.0
	2.0	4.0	6.0	8.0	10.0	12.0
	3.0	5.0	7.0	9.0	11.0	13.0

<sup>1</sup> 205 = RA L

<sup>2</sup> Größter Arbeitsteildurchmesser in 1/10 mm <sup>2</sup> Largest working part diameter in 1/10 mm  Innendurchmesser Internal diameter  Außendurchmesser External diameter

### AUF EINEN BLICK

- Auswahl hochwertiger Trepane für die Extraktion von Knochenzylindern
- Verschiedene Trepan-Größen für jede Anwendung
- Präzise Tiefenmarkierungen für optimale Kontrolle
- Hohe Schnitffreudigkeit für ein besonders gutes Handling

### AT A GLANCE

- Selection of high quality trephines for the extraction of bone cylinders
- Various trephine sizes for every application
- Precise depth markings for optimal control
- High cutting performance for good handling



# Trephine Kit

## Trephine System for Extraction of Cylindrical Bone Grafts

Das Trephine Kit bietet ein breites Sortiment hochwertiger Trepane in feinen Größenabstufungen. Diese sind zum präzisen und einfachen Erstellen von zylindrischen Knochenzylindern sowie zur Knochenentnahme geeignet. Die Trepane haben eine Tiefe von 10 mm und eignen sich speziell für den Einsatz in der Kieferchirurgie und Implantologie. Dank der gut erkennbaren Tiefenmarkierungen im Abstand von jeweils 2 mm kann beim Einsatz jederzeit leicht und sicher die Frästiefe abgelesen werden.

The Trephine Kit provides a broad set of high-quality trephine drills with fine size graduations. These tools are designed specifically for creating cylindrical bone grafts quickly and accurately and for removing defined bone sections. The trephine drills have a depth of 10 mm and have been developed specifically with mandibular surgery and implantology in mind. Thanks to the well-defined laser depth marking in 2 mm intervals, the drilling depth can accurately be monitored.



Art.-No. 7121

Fig.	229	229	229	229	229	229	229	229	229	229	229	229	229
Shank <sup>1</sup>	205	205	205	205	205	205	205	205	205	205	205	205	205
Size <sup>2</sup>	020	025	030	035	040	045	050	055	060	065	070	075	080
Length mm	10.0	10.0	10.0	10.0	10.0	10.0	10.0	10.0	10.0	10.0	10.0	10.0	10.0
□	2.0	2.5	3.0	3.5	4.0	4.5	5.0	5.5	6.0	6.5	7.0	7.5	8.0
*□*	3.0	3.5	4.0	4.5	5.0	5.5	6.0	6.5	7.0	7.5	8.0	8.5	9.0

<sup>1</sup> 205 = RA L    <sup>2</sup> Größter Arbeitsteildurchmesser in 1/10 mm<sup>2</sup> Largest working part diameter in 1/10 mm

□ Innendurchmesser Internal diameter    \*□\* Außendurchmesser External diameter

## AUF EINEN BLICK

- Große Auswahl hochwertiger Trepane für die Extraktion von Knochenzylindern
- Verschiedene Trepan-Größen für jede Anwendung
- Präzise Tiefenmarkierungen für optimale Kontrolle
- Hohe Schnitffreudigkeit für ein besonders gutes Handling

## AT A GLANCE

- Broad selection of high quality trephines for the extraction of bone cylinders
- Various trephine sizes for every application
- Precise depth markings for optimal control
- High cutting performance for good handling



# Trephine Kit Long

## Trephine System for Extraction of Cylindrical Bone Grafts

Das Trephine Kit Long bietet ein breites Sortiment hochwertiger Trepane in feinen Größenabstufungen. Diese sind zum präzisen und einfachen Erstellen von zylindrischen Knochen-Transplantaten sowie zur Knochen-entnahme geeignet. Die Trepane haben eine Tiefe von 14 mm\* und eignen sich speziell für den Einsatz in der Kieferchirurgie und Implantologie. Dank der gut erkennbaren Tiefenmarkierungen im Abstand von jeweils 2 mm kann die Frästiefe während der Behandlung jederzeit leicht und sicher abgelesen werden.

The Trephine Kit provides a broad set of high-quality trephine drills with fine size graduations. These are designed specifically for creating cylindrical bone grafts quickly and accurately and for removing defined bone sections. The trephine drills have a depth of 14 mm\* and have been developed specifically with mandibular surgery and implantology in mind. Thanks to the well-defined laser depth marking in 2 mm intervals, the drilling depth can accurately be monitored.



Art.-No. 7122

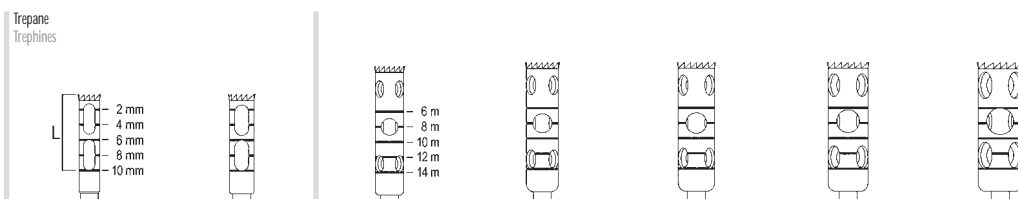

Fig.	229	229	229L	229L	229L	229L	229L	229L
Shank <sup>1</sup>	205	205	205	205	205	205	205	205
Size <sup>2</sup>	020	025	030	035	040	045	050	050
Length mm	10.0	10.0	14.0	14.0	14.0	14.0	14.0	14.0
	2.0	2.5	3.0	3.5	4.0	4.5	5.0	5.0
	3.0	3.5	4.0	4.5	5.0	5.5	6.0	6.0

<sup>1</sup> 205=RA L

<sup>2</sup> Größter Arbeitsteildurchmesser in 1/10 mm <sup>2</sup> Largest working part diameter in 1/10 mm

Innendurchmesser Internal diameter Außendurchmesser External diameter

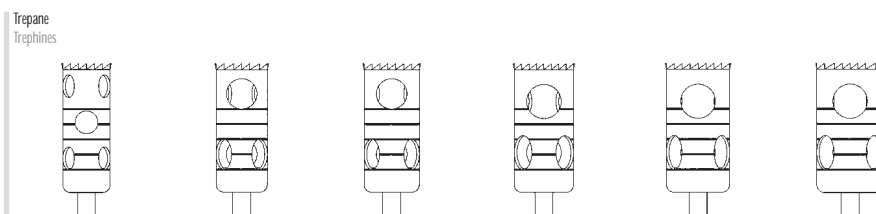

Fig.	229L	229L	229L	229L	229L	229L
Shank <sup>1</sup>	205	205	205	205	205	205
Size <sup>2</sup>	055	060	065	070	075	080
Length mm	14.0	14.0	14.0	14.0	14.0	14.0
	5.5	6.0	6.5	7.0	7.5	8.0
	6.5	7.0	7.5	8.0	8.5	9.0

<sup>1</sup> 205=RA L

<sup>2</sup> Größter Arbeitsteildurchmesser in 1/10 mm <sup>2</sup> Largest working part diameter in 1/10 mm

Innendurchmesser Internal diameter Außendurchmesser External diameter

\* Bitte beachten Sie, dass die Trepane der Durchmesser 2,0 mm und 2,5 mm eine Länge von 10 mm aufweisen.  
Please note that trephines with a diameter of 2.0 mm and 2.5 mm have a length of 10 mm.



# Punch Basic Kit

## Biopsy Punch Set for Extraction of Tissue Grafts

Das Punch Basic Kit enthält Schleimhautstanzen in fünf verschiedenen Durchmessern zur Durchführung von Gewebeentnahmen. Sie dienen dem Einsatz bei Sofortimplantation, zur Hebung von Schleimhauttransplantaten im Rahmen des Weichgewebsmanagements bzw. einer Biopsie sowie zur Freilegung der Gingiva nach Implantation. Die Schleimhautstanzen erzeugen saubere Schnittstellen und sorgen für minimale Gewebetraumatisierung.

The Punch Basic Kit contains Biopsy Punches in five different diameters for the performance of tissue removal. They serve for the application in immediate implant placement, for taking mucosa grafts in the scope of soft tissue management or biopsy as well as for uncovering the gingiva after implantation. The Biopsy Punches create clean cut surfaces and care for minimal tissue traumatization.



Art.-No. 7140

Hautstanzen  
Biopsy punches

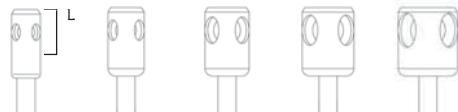

Fig.	225	225	225	225	225
Shank <sup>1</sup>	204	204	204	204	204
Size <sup>2</sup>	030	040	050	060	070
Length mm	6.0	6.0	6.0	6.0	6.0
□	3.0	4.0	5.0	6.0	7.0
*□*	3.7	4.7	5.7	6.7	7.7

<sup>1</sup> 204=RA <sup>2</sup> Größter Arbeitsteildurchmesser in 1/10 mm <sup>2</sup> Largest working part diameter in 1/10 mm

□ Innendurchmesser Internal diameter \*□\* Außendurchmesser External diameter

# Saw Basic Kit

## Selection of Various Diamond Coated Saws for Oral Surgery

Das Saw Basic Kit enthält eine Auswahl diamantierter Sägen in den drei wichtigsten Durchmessern. Sie dienen der Anwendung bei Kieferknochenspreizung und -anhebung. Dank der verschiedenen Größen bietet das Set dem Anwender die Möglichkeit, während der Operation die passende Säge griffbereit zu haben.

The Saw Basic Kit provides a selection of diamond saws in the three most important diameters. They are used for the application in bone spreading or splitting operations. Due to the various sizes, the set offers the clinician the possibility of having a proper selection of these saws during surgery.



Art.-No. 7150

Diamantierete Sägen  
Diamond coated saws



Fig.	231DC*	231DC*, **	231DC*
Shank <sup>1</sup>	204	204	204
Size <sup>2</sup>	070	100	130
Length mm	0.3	0.3	0.3
*□*	7.0	10.0	13.0

<sup>1</sup> 204=RA <sup>2</sup> Größter Arbeitsteildurchmesser in 1/10 mm <sup>2</sup> Largest working part diameter in 1/10 mm

\*\* (2 Stck. / 2 pcs.)

\*□\* Außendurchmesser External diameter



© Dr. Bayer & Drs. Kistler



# Crestal-Lift-Control Basic

## Crestal Approach Sinus Lift System

Crestal-Lift-Control Basic ist ein System für die einfache und sichere Durchführung eines internen Sinuslifts. Die Anhebung der Schneiderschen Membran erfolgt bereits während des transcrestalen Bohrvorgangs. Die besonders atraumatische Konstruktion des Crestal-Bohrers mit seinen vier Schneiden und dem nach innen gewölbten Kopf ermöglicht die sichere Ausformung eines konischen Knochendeckels und lässt sich darüber hinaus ideal zum Ansammeln von Knochenstäben einsetzen. Zusätzlich verhindert das auf die Spezialinstrumente abgestimmte Stopphülzensystem ein Verletzen oder ein Durchbohren der Schneiderschen Membran.

Crestal-Lift-Control Basic ist ein Einstiegssystem mit reduziertem Instrumentarium.

**ACHTUNG:** Um eine Verletzung anatomischer Strukturen zu vermeiden, ist die apikale Überlänge des CL001 von 0,58 mm zu beachten.

Crestal-Lift-Control Basic is a system for the performance of an easy and safe internal sinus lift. The elevation of the Schneiderian membrane occurs during the transcrestal drilling process. The specially atraumatic design of the Crestal Drill with its four cutting edges and concave head allows for a safe forming of a conical bone flap and is more ideally suited for collecting bone chips. Additionally, the stop sleeve system, which is tailored to the special instruments, prevents the membrane from being injured or punctured.

Crestal-Lift-Control Basic is an introductory system with reduced instrument set.

**CAUTION:** To prevent injury of any anatomical structure, the apical extra lengths of the CL001 of 0.58 mm must be considered.



Art.-No. CCLBA



© Dr. Dr. Florian Bauer

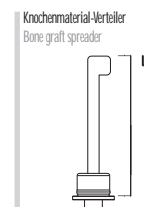
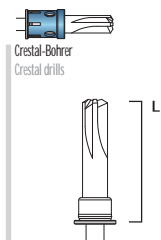
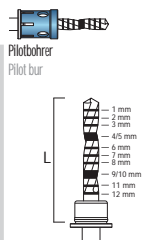

Fig.	CL001	CL004	CL005	CL006	CL007	CL020
Shank <sup>1</sup>	206	206	206	206	206	206
Size <sup>2</sup>	020	033	036	038	041	030
Length mm	16.0	16.0	16.0	16.0	16.0	18.5
Δ	-	-	-	-	-	1.5
□	2.0	3.3	3.6	3.8	4.1	3.0

<sup>1</sup> 206=RA XL

<sup>2</sup> Größter Arbeitstdurchmesser in 1/10 mm <sup>2</sup> Largest working part diameter in 1/10 mm

Δ Minimaldurchmesser Minimal diameter

□ Außendurchmesser External diameter

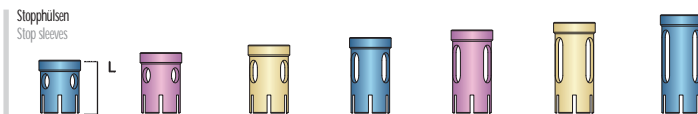

Fig.	CL011	CL012	CL013	CL014	CL015	CL016	CL017
Length mm	7.0	8.0	9.0	10.0	11.0	12.0	13.0
≅ max. drilling depth mm	9.0	8.0	7.0	6.0	5.0	4.0	3.0



# Crestal-Lift-Control

## Crestal Approach Sinus Lift System

Crestal-Lift-Control ist ein System für die einfache und sichere Durchführung eines internen Sinuslifts. Die Anhebung der Schneiderschen Membran erfolgt bereits während des transcrestalen Bohrvorgangs. Die besonders atraumatische Konstruktion des Crestal-Bohrers mit seinen vier Schneiden und dem nach innen gewölbten Kopf ermöglicht die sichere Ausformung eines konischen Knochendeckels und lässt sich darüber hinaus ideal zum Ansammeln von Knochenpänen einsetzen. Zusätzlich verhindert das auf die Spezialinstrumente abgestimmte Stopphülensystem ein Verletzen oder ein Durchbohren der Schneiderschen Membran. Crestal-Lift-Control enthält ein umfassendes Instrumentarium für die sichere Durchführung des internen Sinuslifts.

**ACHTUNG:** Um eine Verletzung anatomischer Strukturen zu vermeiden, ist die apikale Überlänge des CL001 von 0,58 mm zu beachten.

Crestal-Lift-Control is a system for the performance of an easy and safe internal sinus lift. The elevation of the Schneiderian membrane occurs during the transcrestal drilling process. The specially atraumatic design of the Crestal Drill with its four cutting edges and concave head allows for a safe forming of a conical bone flap and is more ideally suited for collecting bone chips. Additionally, the stop sleeve system, which is tailored to the special instruments, prevents the membrane from being injured or punctured.

Crestal-Lift-Control provides an extensive range of instruments for the performance of a safe internal sinus lift.



**CAUTION:** To prevent injury of any anatomical structure, the apical extra lengths of the CL001 of 0.58 mm must be considered.





Art.-No. BCL00





© Dr. Dr. Florian Bauer

	Vorkörner (2 Stk.) Initial burs (2 pcs.)	Diamantinstrument Diamond instrument	Lagerfräser Ablative bur	Pilotbohrer Pilot bur	Crestal-Bohrer Crestal drills					
Fig.	186RF	859*	TC21X	CL001	CL002	CL003	CL004	CL005	CL006	CL007
Shank <sup>1</sup>	204	204	205	206	206	206	206	206	206	206
Size <sup>2</sup>	018	018	040	020	028	031	033	036	038	041
Length mm	12.0	10.0	14.0	16.0	16.0	16.0	16.0	16.0	16.0	16.0
	-	-	-	-	-	-	-	-	-	-
	1.8	1.8	4.0	2.0	2.8	3.1	3.3	3.6	3.8	4.1



<sup>1</sup> 204=RA, 205=RA L, 206=RA XL    <sup>2</sup> Größter Arbeitsteildurchmesser in 1/10 mm    <sup>3</sup> Largest working part diameter in 1/10 mm     Minimaldurchmesser / Minimal diameter     Außendurchmesser / External diameter



	Stopphülse Stop sleeves										
Fig.	CL008	CL009	CL010	CL011	CL012	CL013	CL014	CL015	CL016	CL017	CL018
Length mm	4.0	5.0	6.0	7.0	8.0	9.0	10.0	11.0	12.0	13.0	14.0
± max. drilling depth mm	12.0	11.0	10.0	9.0	8.0	7.0	6.0	5.0	4.0	3.0	2.0

	Knochenmaterial-Verteiler Bone graft spreaders		Tiefenmess-Sonde Depth gauge
Fig.	CL019	CL020	CL021
Shank <sup>1</sup>	206	206	-
Size <sup>2</sup>	020	030	-
Length mm	18.5	18.5	16.0
	1.5	1.5	1.4
	2.5	3.0	2.3

<sup>1</sup> 206=RA XL    <sup>2</sup> Größter Arbeitsteildurchmesser in 1/10 mm    <sup>3</sup> Largest working part diameter in 1/10 mm

 Minimaldurchmesser / Minimal diameter     Außendurchmesser / External diameter



# External-Lift-Control

## External Sinus Lift System

External-Lift-Control ist ein System zur einfachen Durchführung eines externen Sinuslifts. Nach lateralem Zugang durch die fasziale Kieferhöhlenwand, wird die Schneidersche Membran mit den verschiedenen Handinstrumenten abpräpariert und vom Boden der Kieferhöhle nach kranial angehoben. Anschließend kann ein geeignetes Augmentat unter die Schneidersche Membran eingebracht werden. Die spezielle CARBOCER®-Beschichtung der Handinstrumente ermöglicht dabei ein reflektionsfreies Arbeiten.

External-Lift-Control is a system for the easy performance of an external sinus lift. After lateral access through the facial wall of the maxillary sinus, the Schneiderian membrane is detached using the various manual instruments and lifted cranially from the floor of the sinus. Then, a suitable augmentation material can be inserted under the membrane. Due to the special CARBOCER®-coating, the hand-held instruments provide a reflection-free working environment.



Art.-No. BTL00

Diamantinstrumente  
Diamond instruments

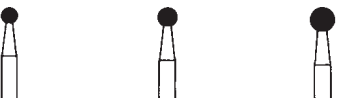

Hartmetallbohrer  
Tungsten carbide burs

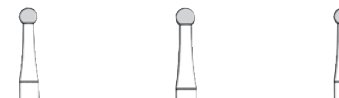

Fig.	801*	801*	801*	HM 1S**	HM 1S**	HM 1S**
Shank <sup>1</sup>	204	204	204	204	204	205
Size <sup>2</sup>	023	027	033	023	027	023
* □ *	2.3	2.7	3.3	2.3	2.7	2.3

<sup>1</sup> 204=RA, 205=RA L, 206=RA XL    <sup>2</sup> Größter Arbeitsteildurchmesser in 1/10 mm    Largest working part diameter in 1/10 mm    \* □ \* Außendurchmesser External diameter



Handinstrumente  
Hand instruments

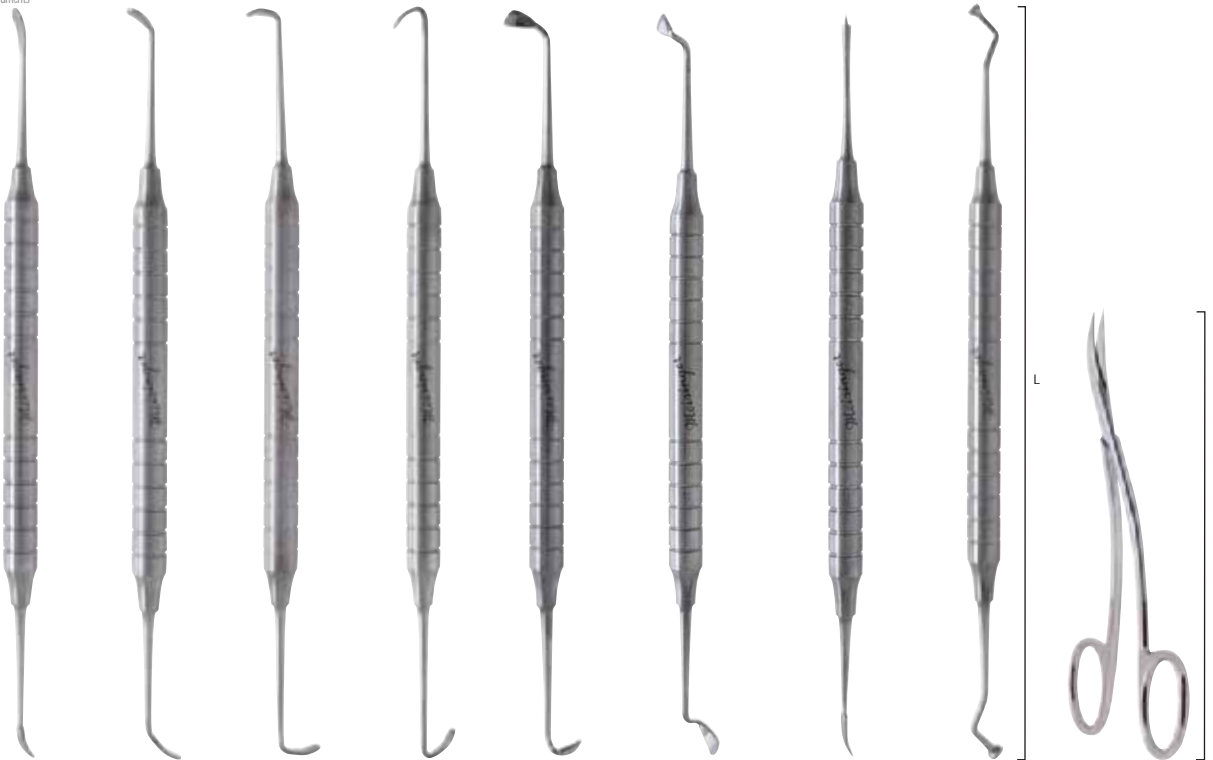

Fig.	TL1	TL2	TL3	TL4	TL5	TL6	TL7	TL8	TL9
Name	Sinuslift	Sinuslift	Sinuslift	Sinuslift	Sinuslift	Sinuslift	Membrane Positioning	Condenser	Scissors
Length mm	173.0	173.0	172.0	174.0	174.5	175.0	170.0	181.0	116.0

# Internal-Lift-Control



## Internal Sinus Lift System

Internal-Lift-Control ist ein System zur Durchführung des internen Sinuslifts. Der Knochen des Implantatalters wird mit Hilfe der Elevatoren in Richtung Kieferhöhle verdrängt. Dieses Verfahren eignet sich bei der Augmentation kleiner vertikaler Defizite bei einer Restknochenhöhe von mehr als 5 mm.

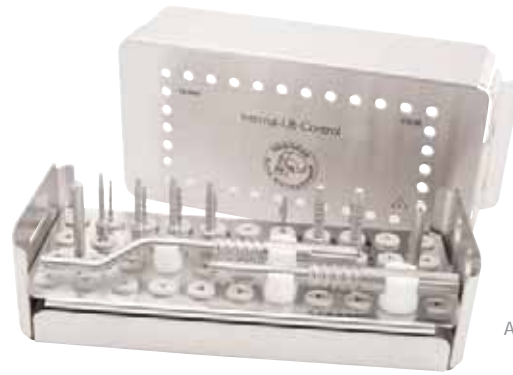
Internal-Lift-Control is a system for the performance of an internal sinus lift. With the aid of the elevators, the bone inside the implant site is displaced in the direction of the maxillary sinus. This procedure is suitable for the augmentation of small defects with a residual bone height of more than 5 mm.



Art.-No. CSL00

	Vorkörner Initial bur	Pilotbohrer Pilot burs	Erweiterer Expansion burs					
Fig.	186RF	B2001	G2001	B2004	E2004	F2004	G2004	H2004
Shank <sup>1</sup>	204	205	205	205	205	205	205	205
Size <sup>2</sup>	018	016	034	027	034	039	045	049
Length mm	12.0	15.0	11.0	12.0	12.0	12.0	11.0	11.0
	-	-	-	1.17	2.44	2.96	3.55	4.07
	1.8	1.6	3.4	2.7	3.4	3.9	4.5	4.9

<sup>1</sup> 204=RA, 205=RA L    <sup>2</sup> Größter Arbeitsteildurchmesser in 1/10 mm<sup>2</sup> Largest working part diameter in 1/10 mm     Minimaldurchmesser Minimal diameter     Außendurchmesser External diameter

	Elevatoren Elevators						Einschlagwerkzeug Impact tool	
Fig.	SL25	SL30	SL35	SL40	SL45	SL50	SL0	SL1
Size <sup>2</sup>	025	030	035	040	045	050	-	-
Length mm	16.0	16.0	16.0	16.0	16.0	16.0	100.0	133.0
	2.5	3.0	3.5	4.0	4.5	5.0	-	-

<sup>2</sup> Größter Arbeitsteildurchmesser in 1/10 mm<sup>2</sup> Largest working part diameter in 1/10 mm

 Außendurchmesser External diameter

Optional erhältlich:  
Optionally available:

Fig.	H1070
Length mm	190.0





# Lift-Control Plus

## Combined System for Internal and External Sinus Lift

Das kombinierte Lift-Control Plus System bietet aufeinander abgestimmte Instrumente sowohl für die Durchführung der internen sowie der externen Sinusbodenelevation. Beim internen Sinuslift wird der Knochen des Implantataltagers mit Hilfe der Elevatoren in Richtung Kieferhöhle verdrängt. Dieses Verfahren eignet sich insbesondere bei der Augmentation kleiner vertikaler Defizite bei einer Restknochenhöhe von mehr als 5 mm. Bei Durchführung des externen Sinuslifts wird ein lateraler Zugang durch die fasziale Kieferhöhlenwand gelegt und die Schneidersche Membran mit Hilfe der verschiedenen Handinstrumente abpräpariert und vom Boden der Kieferhöhle nach kranial angehoben. Anschließend kann ein geeignetes Knochenaugmentat unter die Schneidersche Membran eingebracht werden.

The combined Lift-Control Plus system provides perfectly matched instruments for the performance of internal as well as external sinus floor elevation. For the internal sinus lift, the bone inside the implant site is displaced in the direction of the maxillary sinus. This procedure is suitable for the augmentation of small defects with a residual bone height of more than 5 mm. After lateral access through the facial wall of the maxillary sinus for the performance of the external sinus lift, the Schneiderian membrane is detached using the various manual instruments and lifted cranially from the floor of the sinus. After this, a suitable augmentation material can be inserted under the membrane.



Art.-No. BLIPL

	Vorkörner Initial bur	Diamantinstrumente Diamond instruments		Pilotbohrer Pilot burs		Erweiterer Expansion burs				
Fig.	186RF	242*	242*	B2001	G2001	B2004	E2004	F2004	G2004	H2004
Shank <sup>1</sup>	204	106	106	205	205	205	205	205	205	205
Size <sup>2</sup>	018	030	040	016	034	027	034	039	045	049
Length mm	12.0	-	-	15.0	11.0	12.0	12.0	12.0	11.0	11.0
	-	-	-	-	-	1.17	2.44	2.96	3.55	4.07
*	1.8	3.0	4.0	1.6	3.4	2.7	3.4	3.9	4.5	4.9

<sup>1</sup> 106=HP XL, 204=RA, 205=RA L    <sup>2</sup>Größter Arbeitsteildurchmesser in 1/10 mm<sup>2</sup> Largest working part diameter in 1/10 mm    Minimaldurchmesser Minimal diameter    Außendurchmesser External diameter



	Elevatoren Elevators						Einschlagwerkzeug Impact tool
Fig.	SL25	SL30	SL35	SL40	SL45	SL50	SL0
Size <sup>2</sup>	025	030	035	040	045	050	-
Length mm	16.0	16.0	16.0	16.0	16.0	16.0	100.0
*	2.5	3.0	3.5	4.0	4.5	5.0	-

<sup>2</sup>Größter Arbeitsteildurchmesser in 1/10 mm<sup>2</sup> Largest working part diameter in 1/10 mm    Außendurchmesser External diameter

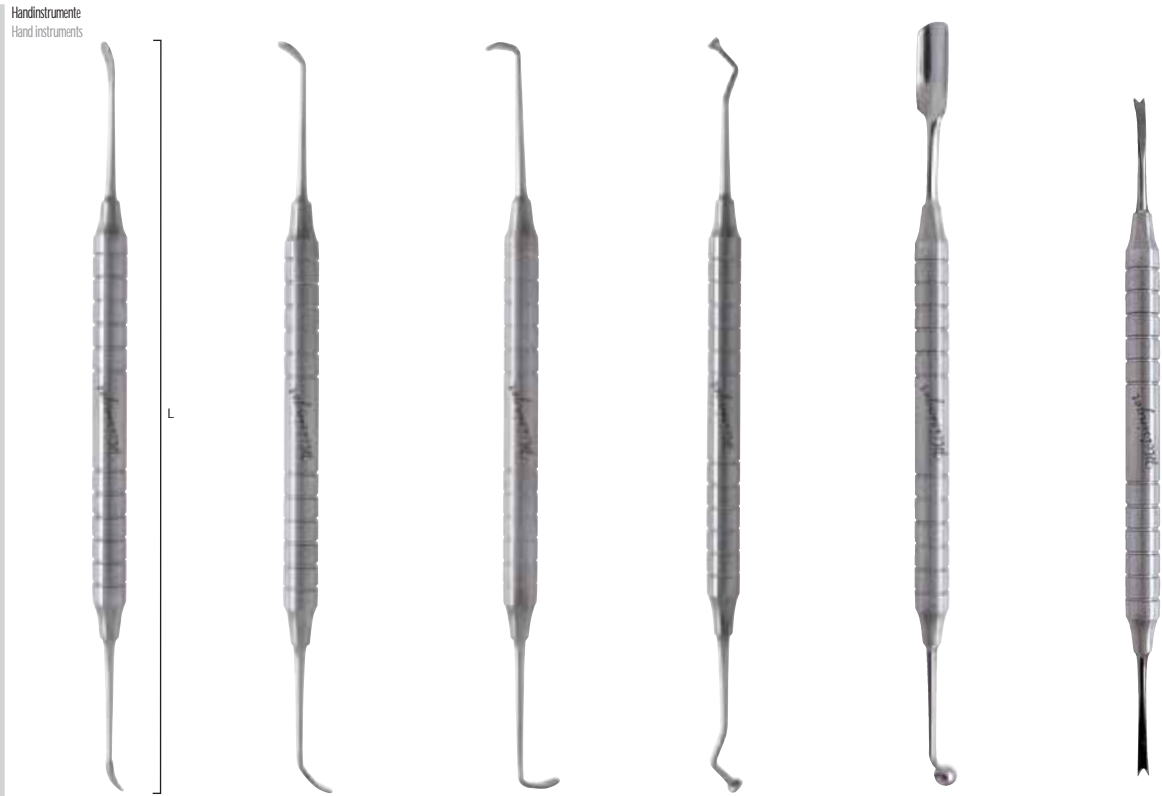

Fig.	TL1	TL2	TL3	TL8	TL19	TL20
Name	Sinuslift	Sinuslift	Sinuslift	Condenser	Applicator	Gauze Packer Luniatschek
Length mm	173.0	173.0	172.0	181.0	182.0	160.0

Optional erhältlich:  
Optionally available:



Fig.	HI070
Length mm	190.0

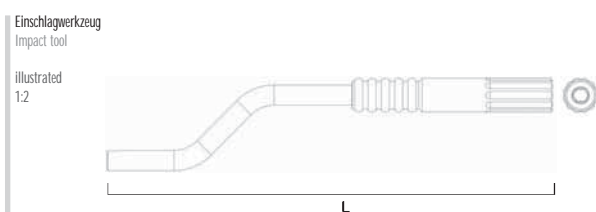

Fig.	SL1
Length mm	133.0



# Surgical Kit 1

## Lateral Approach System for External Sinus Elevation

Das Surgical Kit 1 enthält Instrumente mit Handstückschaft für den lateralen Zugang beim externen Sinuslift. Hartmetallfräser in drei Durchmessern sowie Diamantinstrumente in drei Körnungen ermöglichen das sukzessive Ausdünnen der faszialen Kieferhöhlenwand bis zur Schneiderschen Membran. Dabei schützt der große Durchmesser der Instrumente die Membran vor einer ungewollten Perforation.

The Surgical kit 1 contains instruments with handpiece shank for the lateral approach in an external sinus lift. Carbide cutters in three diameters and diamond instruments in three grains allow for the gradual thinning of the facial bone wall of the maxillary sinus down to the Schneiderian membrane. The large diameter of the instruments protects the membrane from unintentional perforation.



Art.-No. BSKSL

Fig.	HM141F**	HM141F**	HM141F**	HM161RX**	801*	801G*	801H*
Shank <sup>1</sup>	104	104	104	104	104	104	104
Size <sup>2</sup>	018	031	050	018	050	050	050
Length mm	-	-	-	10.5	-	-	-
	-	-	-	-	-	-	-
	1.8	3.1	5.0	1.8	5.0	5.0	5.0

<sup>1</sup> 104 = HP    <sup>2</sup> Größter Arbeitsteildurchmesser in 1/10 mm    <sup>2</sup> Largest working part diameter in 1/10 mm

Minimaldurchmesser Minimal diameter    Außendurchmesser External diameter



## AUF EINEN BLICK

- Zusammenstellung von Handstück-Instrumenten für den lateralen Zugang beim externen Sinuslift
- Runde Instrumente schützen die Schneidersche Membran vor ungewollter Perforation
- Optimal für das sukzessive, sichere Ausdünnen der faszialen Knochenwand
- Runde Diamanten und Hartmetallfräsern in drei unterschiedlichen Durchmessern

## AT A GLANCE

- Compilation of handpiece instruments for the lateral approach during the external sinus lift
- Round instruments protect the Schneiderian membrane from unintentional perforation
- Ideal for gradual, safe thinning of the fascial bone wall
- Round diamonds and carbide burs in three different diameters



# Surgical Kit 2

## Lateral Approach System for External Sinus Elevation

Das Surgical Kit 2 enthält Instrumente mit Winkelstückshaft für den lateralen Zugang beim externen Sinuslift. Hartmetallfräser in drei Durchmessern sowie Diamantinstrumente in drei Körnungen ermöglichen das sukzessive Ausdünnen der faszialen Kieferhöhlenwand bis zur Schneiderschen Membran. Dabei schützt der große Durchmesser der Instrumente die Membran vor einer ungewollten Perforation.

The Surgical Kit 2 contains instruments with right-angled shank for the lateral approach in an external sinus lift. Carbide cutters in three diameters and diamond instruments in three grains allow for the gradual thinning of the facial bone wall of the maxillary sinus down to the Schneiderian membrane. Especially the large diameter of the instruments protects the membrane from unintentional perforation.



Art.-No. BSK02

Fig.	HM141F**	HM141F**	HM141F**	HM161RX**	801*	801G*	801H*
Shank <sup>1</sup>	205	205	205	205	204	204	204
Size <sup>2</sup>	018	031	050	018	050	050	050
Length mm	-	-	-	10.5	-	-	-
	-	-	-	-	-	-	-
*	1.8	3.1	5.0	1.8	5.0	5.0	5.0

<sup>1</sup> 204 = RA, 205 = RA L    <sup>2</sup> Größter Arbeitsteildurchmesser in 1/10 mm    <sup>2</sup> Largest working part diameter in 1/10 mm

Minimaldurchmesser Minimal diameter    Außendurchmesser External diameter

\* \*\*

## AUF EINEN BLICK

- Zusammenstellung von Winkelstück-Instrumenten für den lateralen Zugang beim externen Sinuslift
- Runde Instrumente schützen die Schneidersche Membran vor ungewollter Perforation
- Optimal für das sukzessive, sichere Ausdünnen der faszialen Knochenwand
- Runde Diamanten und Hartmetallfräsern in drei unterschiedlichen Durchmessern

## AT A GLANCE

- Compilation of contra-angle instruments for the lateral approach during the external sinus lift
- Round instruments protect the Schneiderian membrane from unintentional perforation
- Ideal for gradual, safe thinning of the fascial bone wall
- Round diamonds and carbide burs in three different diameters



# Surgical Kit 3

## Easy Cutting Tungsten Carbide Burs for the Efficient Bone Reduction

Das Surgical Kit 3 enthält konische Hartmetallinstrumente mit FG-Schaft verschiedener Größen und Verzahnungen, die ein breites Einsatzgebiet in der Kieferchirurgie ermöglichen. Die besonders schnittfreudigen und effizienten Fräser besitzen einen extra langen Schaft für beste Sicht auf das Arbeitsfeld und eine scharfe Spitze für den sicheren Einsatz im Knochen.

The Surgical Kit 3 contains conical Tungsten Carbide Burs with friction grip shank of various sizes and toothing which allow for a broad field of application. The particularly easy cutting and efficient cutters have an extra-long shank for an optimal view on the working area and sharp tips for the safe application in bone.



Art.-No. BSK03

Hartmetallinstrumente  
Tungsten carbide burs

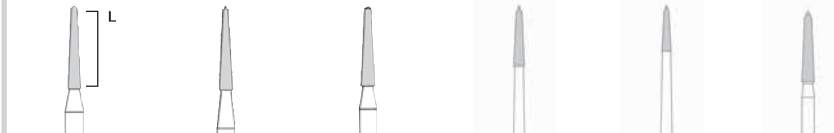

Fig.	HM151*	HM161*	HM162*	HM162SX*	HM254LE*	HM408M*
Shank <sup>1</sup>	316	316	316	314	314	316
Size <sup>2</sup>	016	018	016	014	012	016
Length mm	10.0	10.5	10.5	8.0	6.0	9.5
	-	-	-	-	-	-
	1.6	1.8	1.6	1.4	1.2	1.6

<sup>1</sup> 314=FG, 316=FG XL    <sup>2</sup> Größter Arbeitsteildurchmesser in 1/10 mm    <sup>2</sup> Largest working part diameter in 1/10 mm

Minimaldurchmesser Minimal diameter    Außendurchmesser External diameter



# Surgical Kit 4

## Selection of Conical Tungsten Carbide Burs

Das Surgical Kit 4 enthält eine Auswahl konischer Hartmetallfräser mit Handstückschaft für ein breites Einsatzgebiet in der Kieferchirurgie. Die Fräser besitzen eine besonders schnittfreudige und effiziente Sägeverzahnung und einen gezielt ausgerichteten Drallwinkel. Die schmalen Arbeitsteile ermöglichen dabei beste Sicht auf das Arbeitsfeld.

The Surgical Kit 4 contains a selection of conical Tungsten Carbide Cutters with handpiece shank for a broad field of application in oral surgery. The cutters have a particularly easy cutting and efficient saw toothing and a specifically designed twist angle. Further, the narrow working parts allow for an optimal view on the working area.



Art.-No. BSK04

Hartmetallinstrumente  
Tungsten carbide burs



Fig.	HM162A*	HM162SL*	HM163A*	HM166A*	HM254*	HM408M*
Shank <sup>1</sup>	104	104	104	104	104	104
Size <sup>2</sup>	016	014	014	021	012	016
Length mm	9.3	8.0	5.0	10.5	6.0	9.6
	-	-	-	-	-	-
	1.6	1.4	1.4	2.1	1.2	1.6

<sup>1</sup> 104=HP    <sup>2</sup> Größter Arbeitsteildurchmesser in 1/10 mm    <sup>2</sup> Largest working part diameter in 1/10 mm

Minimaldurchmesser Minimal diameter    Außendurchmesser External diameter







# Alveoplasty Surgical Kit

## Surgical Contouring and Modification Kit

Das Alveoplasty Surgical Kit enthält die wichtigsten Instrumente zur chirurgischen Konturierung und Modifizierung des Kieferkammes, wenn es nach der Extraktion eines Zahns oder durch stattgefundenen Knochenabbau zu unerwünschten Unebenheiten des Kieferknochens kommt. In diesem Fall bietet das Kit die optimale Möglichkeit den Kieferknochen zu glätten. Das Alveoplasty Kit enthält je zwei Vorkörner und Lindemannfräser, die die Durchführung von präzisen, initialen Osteotomien, auch im harten kortikalen Knochen, erlauben. Zur Durchführung der Alveoplastik selbst, dienen fünf unterschiedliche Hartmetallfräser und ein kugelförmiger Diamant. Die runden Arbeitsteilformen schützen dabei optimal vor Verletzungen des Weichgewebes. So wird der Kieferknochen schonend und präzise für die Implantatinserterion oder die Versorgung mit einer Totalprothese vorbereitet.



Art.-No. ALV18

The Alveoplasty Surgical Kit contains the most important instruments for surgical contouring and modification of the alveolar ridge when unwanted unevenness of the jawbone occurs after tooth extraction or bone degeneration. In this case, the kit offers the best way to smooth the jawbone. The Alveoplasty Kit contains two initial burs and two Lindemann burs, which allow for the performance of precise, initial osteotomies, even in hard cortical bone. To perform the alveoplasty itself, five different carbide cutters and a round diamond are included. The round working parts optimally protect the soft tissue against injuries. Thus, the alveolar ridge is prepared carefully and precisely for implant insertion or denture restoration.

	Vorkörner (2 Stk.) Initial burs (2 pcs.)	Chirurgiefräser Surgical cutters	Hartmetallinstrumente Tungsten Carbide Instruments				Diamantinstrument Diamond instrument		
Fig.	186RF	HM166**	165RF	HM71**	HM71**	HM72GX**	HM77GX**	HM251GX**	801*
Shank <sup>1</sup>	204	205	205	104	104	104	104	104	204
Size <sup>2</sup>	018	021	023	040	050	060	060	040	033
Length mm	12.0	11.0	7.0	-	-	12.0	11.5	8.3	-
* □ *	1.8	2.1	2.3	4.0	5.0	6.0	6.0	4.0	3.3

<sup>1</sup> 204=RA, 205=RA L, 206=RA XL

<sup>2</sup> Größter Arbeitsteildurchmesser in 1/10 mm <sup>2</sup> Largest working part diameter in 1/10 mm

\* □ \* Außendurchmesser External diameter



Optional erhältlich:  
Optionally available:

Konturierer  
Ridge Contouring Bur

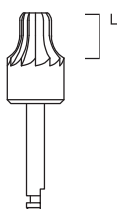

Fig.	RCB00
Shank <sup>1</sup>	205
Size <sup>2</sup>	075
Length mm	6.0
▲	4.2
* □ *	7.5

▲ Minimaldurchmesser Minimal diameter

\* □ \* Außendurchmesser External diameter



# Implant Preparation Kit with Stop

## Initial Bur System with Stop for Safe Implant Site Preparation

Das Implant Preparation Kit with Stop dient der einfachen und sicheren Aufbereitung des Implantatlagers. Die Stopphülsen erlauben einen definierten Tiefenstopp sowohl während des Vorkörnens, als auch während der Pilotbohrung. Für die Anwendung ohne Stopphülsen sind die Instrumente mit Lasermarkierungen ausgestattet.

**ACHTUNG:** Um eine Verletzung anatomischer Strukturen zu vermeiden, ist die apikale Überlänge des Pilotbohrers von 0,8 mm zu beachten.

The Implant Preparation Kit provides the easy and safe preparation of the implant site. The stop sleeves allow for a defined depth stop during the initial and pilot drilling. For the application without stop sleeves, the instruments are equipped with laser markings.

**CAUTION:** To prevent injury of any anatomical structure, the apical extra length of the pilot drill of 0.8 mm must be considered.



Art.-No. IPK02

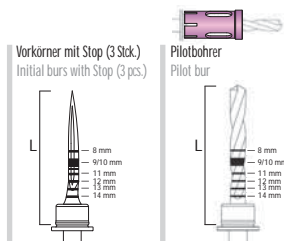

Fig.	187RF	TDS15
Shank <sup>1</sup>	204	204
Size <sup>2</sup>	018	020
Length mm	19.0	19.0
□	1.8	2.0

<sup>1</sup> 204 = RA    <sup>2</sup> Größter Arbeitsteildurchmesser in 1/10 mm    <sup>2</sup> Largest working part diameter in 1/10 mm

□ Außendurchmesser External diameter

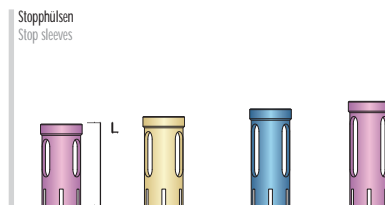

Fig.	CL038	CL039	CL040	CL041
Length mm	11.0	12.0	13.0	14.0
△ max. drilling depth mm	8.0	7.0	6.0	5.0

## AUF EINEN BLICK

- Einfache und sichere Aufbereitung des Implantatlagers
- Definierter Tiefenstopp beim Vorkörnen und Erweitern
- Farbige Markierung der Stopphülsen zur einfachen Unterscheidung
- Zusätzlich tiefenmarkierte Instrumente für den optionalen Einsatz ohne Stopphülsen

## AT A GLANCE

- Simple and safe preparation of the implant site
- Defined depth stop during initial and extension drilling
- Colored marking of the stop sleeves for easy differentiation
- Additional depth-marked instruments for optional use without stop sleeves



# Drill-Stop-Control (BL + TL)



## Drill System for Safe Implant Site Preparation

Das Drill-Stop-Control System dient der einfachen und sicheren Aufbereitung des Implantatlagers. Die ansteigenden Durchmesser der Spiralbohrer sind dabei perfekt aufeinander abgestimmt. Die Stophülzen dienen dem definierten Tiefenstopp sowohl während der Pilot-, als auch während der Erweiterungsbohrung. Für die Anwendung ohne Stophülzen sind die Instrumente mit Lasermarkierungen ausgestattet.

**ACHTUNG:** Um eine Verletzung anatomischer Strukturen zu vermeiden, ist die apikale Überlänge der Instrumente von 0,8 mm zu beachten.

The Drill-Stop-Control system provides an easy and safe preparation of the implant site. The increasing diameters of the twist drills are perfectly coordinated with each other. The stop sleeves provide the defined depth stop during the pilot drilling and during the expansion of the implant site. For the application without stop sleeves, the instruments are equipped with laser markings.

**CAUTION:** To prevent injury of any anatomical structure, the apical extra length of the instruments of 0.8 mm must be considered.



Art.-No. BDS00

### Wichtig | Important

Die Durchmesser der Spiralbohrer sind abgestimmt auf zylindrische Implantate der Dental Ratio® und Straumann® Implantatsysteme. The diameters of the twist drills fit together with cylindrical implants of the Dental Ratio® and Straumann® implant systems.

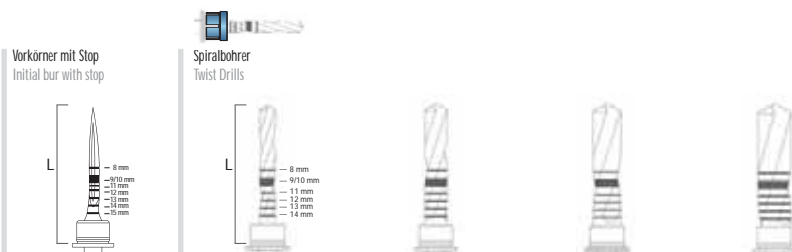

Fig.	187RF	TDS15	TDS15	TDS15	TDS15
Shank <sup>1</sup>	204	204	204	204	204
Size <sup>2</sup>	018	020	028	035	042
Length mm	19.0	19.0	19.0	19.0	19.0
* □ *	1.8	2.0	2.8	3.5	4.2

<sup>1</sup> 204 = RA <sup>2</sup> Größter Arbeitsteildurchmesser in 1/10 mm <sup>2</sup> Largest working part diameter in 1/10 mm

\* □ \* Außendurchmesser External diameter

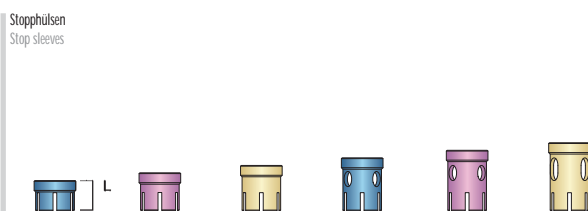

Fig.	CL031	CL032	CL033	CL034	CL035	CL036
Length mm	4.0	5.0	6.0	7.0	8.0	9.0
≅ max. drilling depth mm	15.0	14.0	13.0	12.0	11.0	10.0



# Drill-Stop-Control (BLT)

## Drill System for Safe Implant Site Preparation

Das Drill-Stop-Control BLT dient der einfachen und sicheren Aufbereitung des Implantatlagers für Bone Level Tapered Implantate des Straumann® oder Dental Ratio® Implantatsystems. Die ansteigenden Durchmesser der Spiralbohrer sind dabei perfekt aufeinander abgestimmt. Die Stopphülsen dienen dem definierten Tiefenstopp sowohl während der Pilot-, als auch während der Erweiterungsbohrung. Für die Anwendung ohne Stopphülsen sind die Instrumente mit Lasermarkierungen ausgestattet.

**ACHTUNG:** Um eine Verletzung anatomischer Strukturen zu vermeiden, ist die apikale Überlänge der Instrumente von 0,4 mm zu beachten.

The Drill-Stop-Control BLT provides an easy and safe preparation of the implant site for Bone Level Tapered implants of the Straumann® or Dental Ratio® implant system. The increasing diameters of the twist drills are perfectly coordinated with each other. The stop sleeves provide the defined depth stop during the pilot drilling and during the expansion of the implant site. For the application without stop sleeves, the instruments are equipped with laser markings.

**CAUTION:** To prevent injury of any anatomical structure, the apical extra length of the instruments of 0.4 mm must be considered.

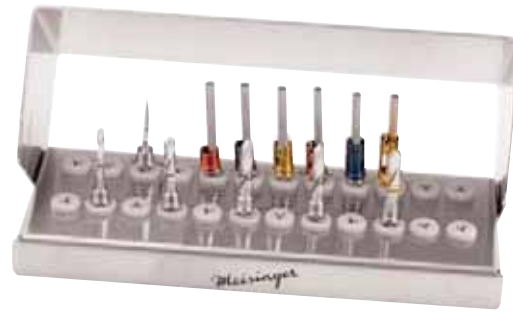

Art.-No. BDS02

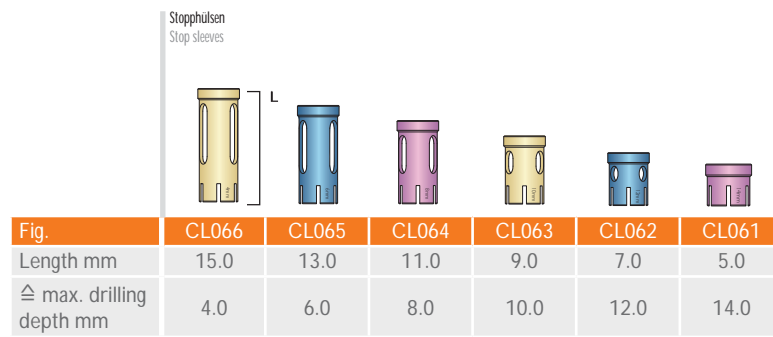
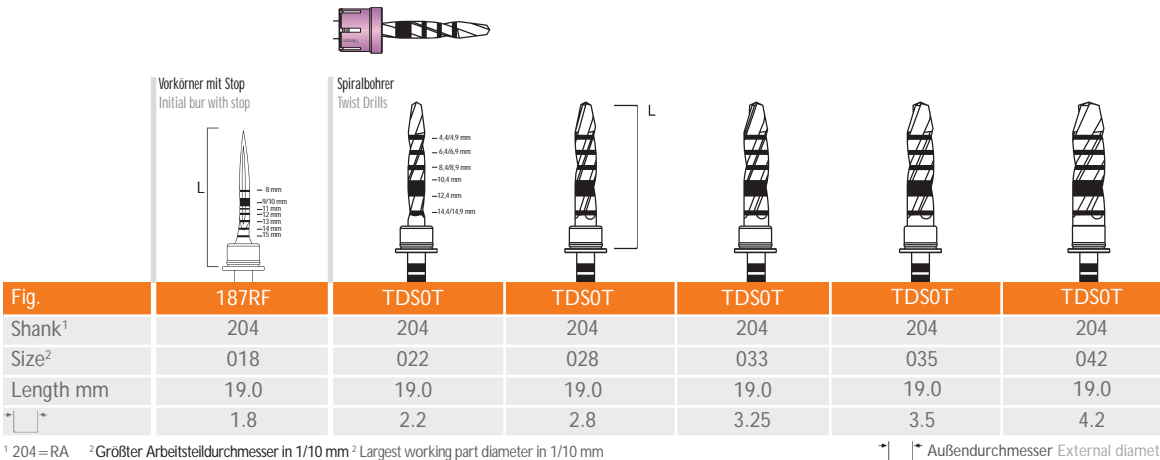



# Drill-Stop-Control (myplant two)

## Drill System for Safe Implant Site Preparation

Mit dem speziell für myplant two entwickelten Drill-Stop-Control System gelingt die Aufbereitung des Implantatlagers besonders einfach und sicher, da die Durchmesser der Spiralbohrer perfekt auf das myplant two Implantatsystem abgestimmt sind. Die Stopphülsen werden sowohl während der Pilot- als auch der Erweiterungsbohrung für den definierten Tiefenstopp eingesetzt. Die Längen der Stopphülsen eignen sich ideal für die subcrestale Platzierung des Implantats. Für die Anwendung ohne Stopphülsen sind die Instrumente mit Lasermarkierungen ausgestattet.

**ACHTUNG:** Um eine Verletzung anatomischer Strukturen zu vermeiden, sind die apikalen Überlängen der Instrumente zu beachten.

With the specially for myplant two developed Drill-Stop-Control system, the preparation of the implant site is particularly easy and safe, since the diameters of the twist drills are perfectly matched to the myplant two implant system. The stop sleeves are used both during the pilot and the extension drilling for the defined depth stop. The lengths of the stop sleeves are ideal for subcrestal placement of the implant. For application without stop sleeves, the instruments are equipped with laser markings.

**CAUTION:** To prevent injury of any anatomical structure, the apical extra lengths of the instruments must be considered.



Art.-No. BDSMP

**Wichtig | Important**

Die Durchmesser sind perfekt abgestimmt auf das *myplant two* Implantatsystem.  
Diameters fit perfectly with the *myplant two* implant system.

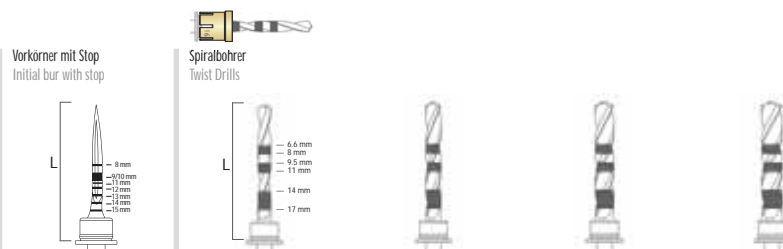

Fig.	187RF	TDS18	TDS18	TDS18	TDS18
Shank <sup>1</sup>	204	204	204	204	204
Size <sup>2</sup>	018	020	024	029	033
Length mm	19.0	22.0	22.0	22.0	22.0
Apical extra lengths	-	-	0.4	0.5	0.6
	1.8	2.0	2.4	2.9	3.3

<sup>1</sup> 204=RA <sup>2</sup> Größter Arbeitsteildurchmesser in 1/10 mm <sup>2</sup> Largest working part diameter in 1/10 mm

Außendurchmesser External diameter

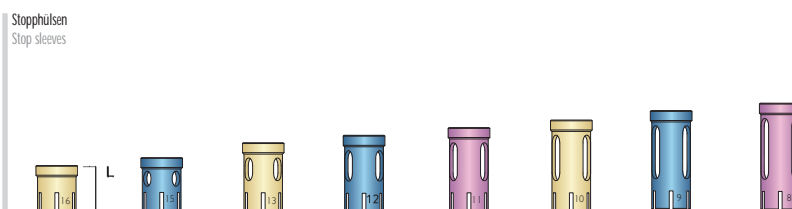

Fig.	CL050	CL051	CL052	CL053	CL054	CL055	CL056	CL057
Length mm	6.0	7.0	9.0	10.0	11.0	12.0	13.0	14.0
≅ max. drilling depth mm	16.0	15.0	13.0	12.0	11.0	10.0	9.0	8.0



# Guided-Drill-Stop-Control

Guided Drill System for Safe Implant Site Preparation | developed with Dr. Henriette Lerner

Das Guided-Drill-Stop System dient der einfachen und sicheren Aufbereitung des Implantatlagers. Die Besonderheit des Systems sind die speziell entwickelten Spiralbohrer mit Führungsspitze, mit denen vor der eigentlichen Erweiterungsbohrung ein Zwischenschritt durchgeführt wird. Dabei wird der obere Teil des Implantatlagers auf den gewünschten Durchmesser erweitert, während der untere Teil der Führung des Bohrers dient. So wird ein Abweichen von der gewünschten Achse vermieden. Zusätzlich sorgen die Stopphülsen für den definierten Tiefenstopp während allen Bohrungen.

**ACHTUNG:** Um eine Verletzung anatomischer Strukturen zu vermeiden, ist die apikale Überlänge der Instrumente von 0,8 mm zu beachten.

The Guided-Drill-Stop system is used for the easy and safe preparation of the implant site. The special feature of the system are the specially developed twist drills with guiding tip, with which an intermediate step is added prior to the actual extension drilling. With this step, the upper part of the implant site is expanded to the desired diameter, while the lower part is used to guide the drill. This avoids deviation from the desired axis. In addition, the stop sleeves provide the defined depth stop during all drillings.

**CAUTION:** To prevent injury of any anatomical structure, the apical extra length of the instruments of 0.8 mm must be considered.

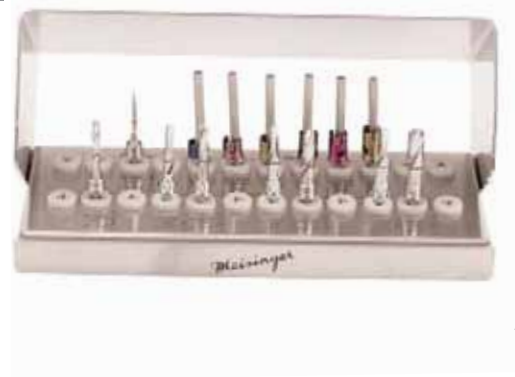

Art.-No. BGS00

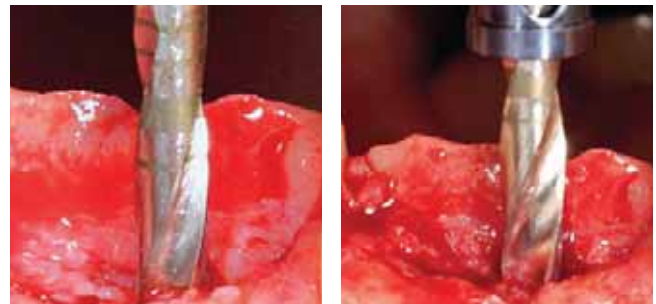

© Dr. Henriette Lerner

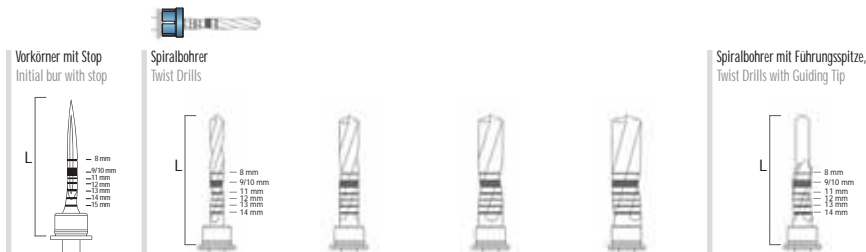

Fig.	187RF	TDS0G	TDS0G	TDS0G	TDS0G	TDS08	TDS08	TDS08
Shank <sup>1</sup>	204	204	204	204	204	204	204	204
Size <sup>2</sup>	018	020	028	035	042	028	035	042
Length mm	19.0	19.0	19.0	19.0	19.0	19.0	19.0	19.0
*□*	1.8	2.0	2.8	3.5	4.2	2.8	3.5	4.2

<sup>1</sup> 204=RA <sup>2</sup> Größter Arbeitsteildurchmesser in 1/10 mm <sup>2</sup> Largest working part diameter in 1/10 mm

\*□\* Außendurchmesser External diameter

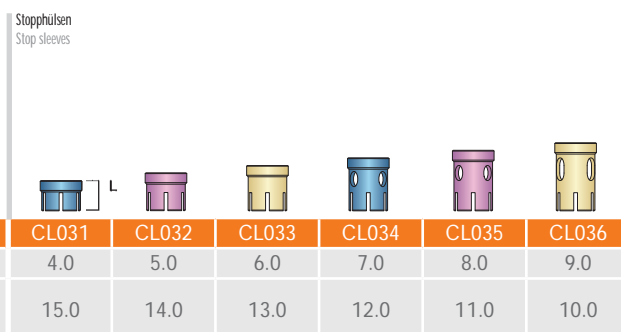
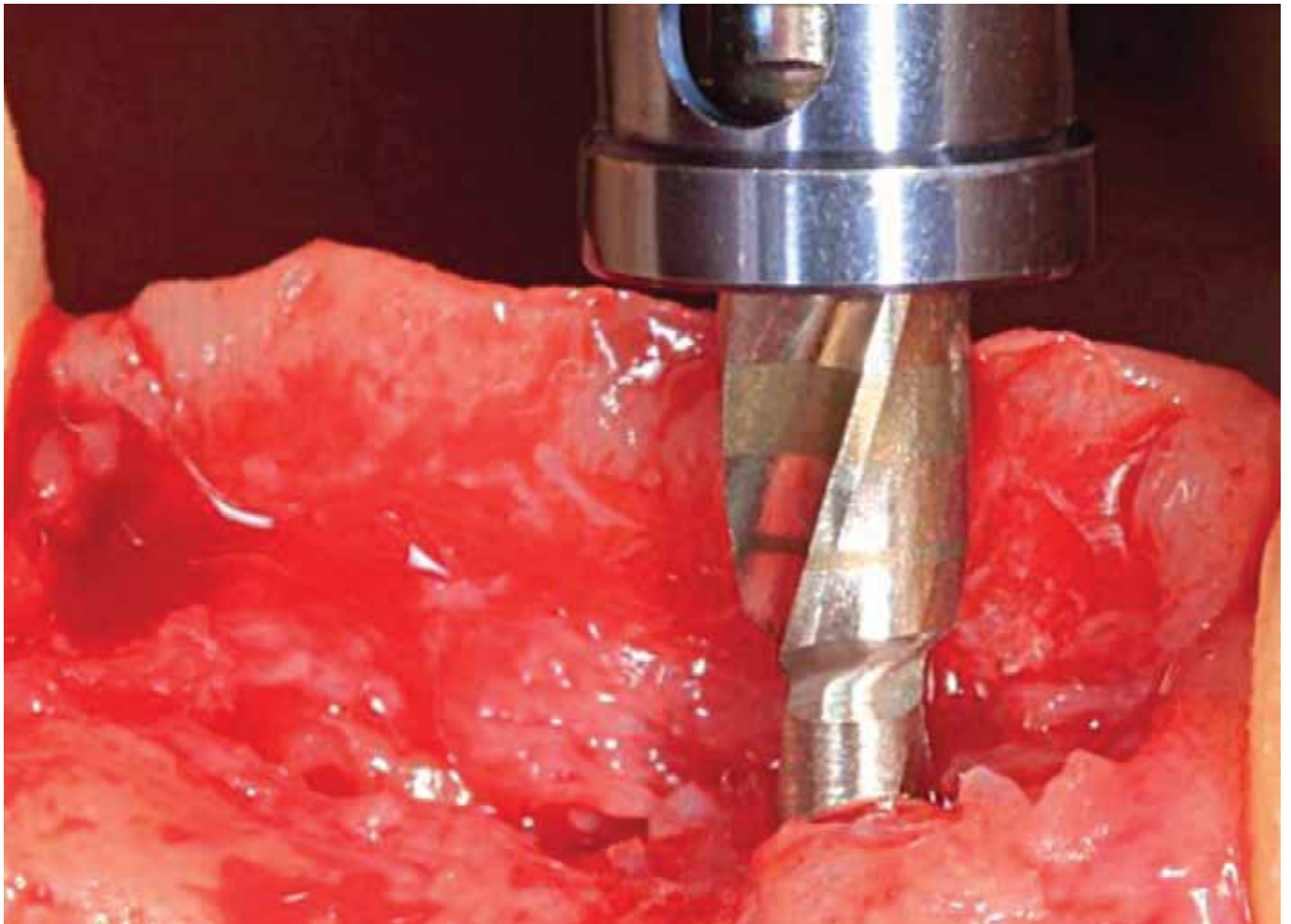

Fig.	CL031	CL032	CL033	CL034	CL035	CL036
Length mm	4.0	5.0	6.0	7.0	8.0	9.0
≅ max. drilling depth mm	15.0	14.0	13.0	12.0	11.0	10.0



### Wichtig | Important

Die Durchmesser der Spiralbohrer sind abgestimmt auf zylindrische Implantate der Dental Ratio® und Straumann® Implantatsysteme. The diameters of the twist drills fit together with cylindrical implants of the Dental Ratio® and Straumann® implant systems.



HL-DENTCLINIC  
www.hl-dentclinic.de

Developed with  
**Dr. Henriette Lerner**

Baden-Baden, Germany





# 3D-Navigation-Control

Guided Sleeve System | developed with Dr. Hans-Joachim Nickenig

3D-Navigation-Control ist ein Führungshülensystem, welches für alle gängigen Implantatsysteme und Planungsprogramme geeignet ist. Dank der enthaltenen geschlossenen Standardhülsen und der offenen Führungshülsen für den Molarenbereich, erlaubt das Sortiment den Einsatz von Führungsschablonen sowohl im Frontzahnbereich als auch in eingengter Molarensituation. Das System erfüllt darüber hinaus spezielle instrumentelle Erfordernisse einer Flapless Surgery. Das 3D-Navigation-Control System enthält ein separates 3D-Laboratory-Kit, das dem Zahntechniker die exakte Hülseninstallation in der Schablone ermöglicht.

3D-Navigation-Control is a guiding sleeve system that is suitable for all commonly used implant systems and planning programs. Due to the included closed standard sleeves and the open guiding sleeves for the molar region, the system permits the use of surgical guide templates in the anterior region and even in tight molar situations. In addition, the system provides special tool requirements of flapless surgery. The 3D-Navigation-Control system contains a separate 3D-Laboratory Kit so the dental technician is able to install the sleeves in the template precisely.

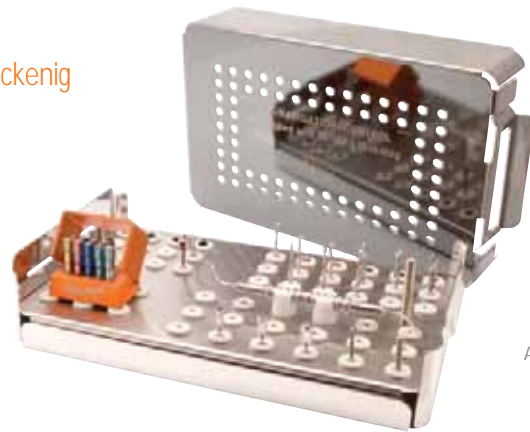

Anwendungsvideo  
Application Video

Art.-No. BNA00



© Dr. Hans-Joachim Nickenig

Inhalt | content: 3D-Navigation-Control & 3D-Navigation-Control Professional

Fig.	HN010	HN011	HN012	HN013	HN014	HN015	HN016	HN017	HN018
Shank <sup>1</sup>	205	206	206	206	206	206	206	206	206
Size <sup>2</sup>	020	020	025	030	035	040	020	025	030
Length mm	16.0	19.0	19.0	19.0	19.0	19.0	22.0	22.0	22.0
□ □	2.0	2.0	2.5	3.0	3.5	4.0	2.0	2.5	3.0

<sup>1</sup> 205= RA L, 206=RA XL <sup>2</sup> Größter Arbeitsteildurchmesser in 1/10 mm <sup>3</sup> Largest working part diameter in 1/10 mm □ □ Außendurchmesser External diameter

Inhalt | content: 3D-Navigation-Control & 3D-Navigation-Control Professional

Fig.	225	225	225	64557	64556	BV040	SW150	HN020
Shank <sup>1</sup>	204	204	204	-	-	206	-	-
Size <sup>2</sup>	030	040	050	-	-	-	-	-
Length mm	6.0	6.0	6.0	16.0	16.0	40.0	20.0	119.0
□ □	3.0	4.0	5.0	-	-	-	-	1.5 / 2.0
□ □	3.7	4.7	5.7	2.0	3.0	-	-	2.0 / 3.5

<sup>1</sup> 204=RA, 206=RA XL <sup>2</sup> Größter Arbeitsteildurchmesser in 1/10 mm <sup>3</sup> Largest working part diameter in 1/10 mm □ □ Innendurchmesser Internal diameter □ □ Außendurchmesser External diameter





# 3D-Navigation-Control Professional

Guided Sleeve System | developed with Dr. Hans-Joachim Nickenig

3D-Navigation-Control Professional ist ein Führungshülensystem, welches für alle gängigen Implantatsysteme und Planungsprogramme geeignet ist. Dank der enthaltenen geschlossenen Standardhülsen und der offenen Führungshülsen für den Molarenbereich, erlaubt das Sortiment den Einsatz von Führungsschablonen sowohl im Frontzahnbereich als auch in eingengter Molarensituation. Das System erfüllt darüber hinaus spezielle instrumentelle Erfordernisse einer Flapless Surgery. Das 3D-Navigation-Control Professional System enthält ein separates 3D-Laboratory-Kit, das dem Zahntechniker die exakte Hülseninstallation in der Schablone ermöglicht.

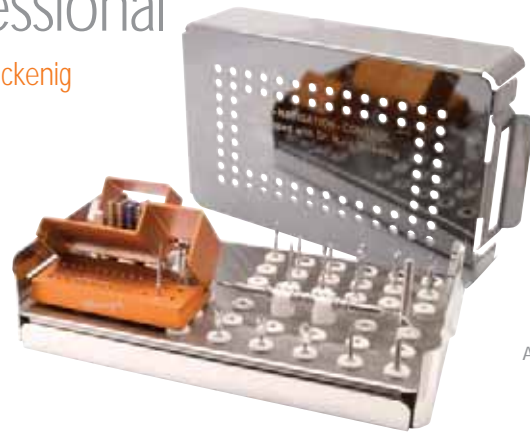

Anwendungsvideo  
Application Video

Art.-No. BNAPR

Das Professional System bietet ein zusätzliches, separat enthaltenes 3D-Fixation Kit, das die (optionale) Fixierung der Führungsschablone ermöglicht.

3D-Navigation-Control Professional is a guiding sleeve system that is suitable for all commonly used implant systems and planning programs. Due to the included closed standard sleeves and the open guiding sleeves for the molar region, the system permits the use of surgical guide templates in the anterior region and even in tight molar situations. In addition, the system provides special tool requirements of flapless surgery. The 3D-Navigation-Control Professional system contains a separate 3D-Laboratory Kit so the dental technician is able to install the sleeves in the template precisely.



© Dr. Hans-Joachim Nickenig

The Professional system offers an additional, separate 3D-Fixation Kit, which allows for the (optional) fixation of the surgical guide template.

## Inhalt | content: 3D-Navigation-Control & 3D-Navigation-Control Professional

	Standard Führungshülsen, geschlossen (je 4 Stk.) Standard guiding sleeves, closed (each 4 pcs.)					Molare Führungshülsen, offen (je 4 Stk.) Molar guiding sleeves, open (each 4 pcs.)				Schablonenbohrer Template drills	
Fig.	HN001	HN002	HN003	HN004	HN005*	HN006	HN007	HN008	HN009*	HN021	HN022
Shank <sup>1</sup>	-	-	-	-	-	-	-	-	-	205	205
Size <sup>2</sup>	-	-	-	-	-	-	-	-	-	045/055	060/065
Length mm	6.0	6.0	6.0	6.0	6.0	5.5	5.5	5.5	6.0	13.0	13.0
□	2.0	2.5	3.0	3.5	4.0	2.0	3.0	4.0	5.0	-	-
□	4.0	4.0	4.0	4.0	4.5	5.0	5.0	5.0	6.0	5.5	6.5
△	-	-	-	-	-	-	-	-	-	4.5	6.0

<sup>1</sup> 205=RA L    <sup>2</sup> Größter Arbeitsteildurchmesser in 1/10 mm    <sup>2</sup> Largest working part diameter in 1/10 mm

△ Minimaldurchmesser Minimal diameter    □ Innendurchmesser Internal diameter    □ Außendurchmesser External diameter

## Zusätzlicher Inhalt | Additionally content: 3D-Navigation-Control Professional

	Kugelhkopfancker (je 10 Stück) Ball-head anchors (each 10 pcs.)		Schraubendreher Screw driver		Spiralbohrer Twist drill
Fig.	HN023*	HN024*	TC0SW	UG00W	HN019
Shank <sup>1</sup>	-	-	204	-	205
Size <sup>2</sup>	-	-	-	-	010
Length mm	8.0	11.0	13.0	12.0	12.0
△	1.0	1.0	-	-	-
□	1.3	1.3	-	-	1.0
Head-Ø mm	2.25	2.25	-	-	-

<sup>1</sup> 204=RA, 205=RA L    <sup>2</sup> Größter Arbeitsteildurchmesser in 1/10 mm    <sup>2</sup> Largest working part diameter in 1/10 mm

△ Minimaldurchmesser Minimal diameter    □ Außendurchmesser External diameter

Developed with  
**Dr. Hans-Joachim  
Nickenig**  
Köln, Germany



# Periimplantitis Kit

## Tungsten Carbide Finishers for Periimplantitis Treatment

Das Periimplantitis Kit beinhaltet acht perfekt aufeinander abgestimmte Hartmetallfinierer in Ei- und Flammenform zur optimalen Periimplantitis-Behandlung. Beide Formen liegen in zwei Größen und jeweils in Standard- und ultra feiner Verzahnung vor. Die Arbeitsteilformen, -größen, und -verzahnungen eignen sich optimal zur intraoralen Bearbeitung von Titan und für verschiedene Formen von Implantat Hals und -schulter. Alle enthaltenen Finierer besitzen einen extra langen FG Schaft (Gesamtlänge 32 mm) mit dem insbesondere schwer zugängliche, tiefe Bereiche erreicht werden können. Für die Behandlung der Periimplantitis werden die Finierer rechtsläufig gegen den Uhrzeigersinn um den freiliegenden Teil des Implantats herumgeführt, um die Implantatoberfläche zu glätten.

The Periimplantitis Kit contains eight perfectly matched tungsten carbide finishing burs in egg and flame shapes for the idea peri-implantitis treatment. Both shapes come in two sizes and each in standard and ultra-fine toothing. The shapes, sizes and toothings of the working parts are perfectly suited for the intraoral treatment of titanium and for different shapes of implant neck and shoulder. All finishers have an extra-long FG shank (total length 32 mm) which allows particularly the treatment of difficult-to-access, deep areas. For the peri-implantitis treatment, the finishers are used clockwise and are guided around the exposed implant counter-clockwise so the implant surface is smoothed.



Art.-No. 2575



© Dr. Georg Bach

Hartmetallfinierer  
Tungsten carbide finishing burs

Fig.	HM379*	HM379*	HM48L*	HM48L*	HM379U*	HM379U*	HM48LU*	HM48LU*
Shank <sup>1</sup>	317	317	317	317	317	317	317	317
Size <sup>2</sup>	014	023	014	023	014	023	014	023
Length mm	3.1	4.2	8.0	8.0	3.1	4.2	8.0	8.0
*  *	1.4	2.3	1.4	2.3	1.4	2.3	1.4	2.3

<sup>1</sup> 317=FG XXL    <sup>2</sup> Größter Arbeitsteildurchmesser in 1/10 mm<sup>2</sup> Largest working part diameter in 1/10 mm

\*  \* Außendurchmesser External diameter



## AUF EINEN BLICK

- Optimal abgestimmte Hartmetallfinierer für die effektive, intraorale Bearbeitung von Titan
- XXL FG Schaft erleichtert die Arbeit an schwer zugänglichen Implantaten
- Verschiedene Formen und Größen für jede Patientensituation
- Saubere und glatte Titanoberflächen

## AT A GLANCE

- Perfectly matched tungsten carbide finishing burs for the effective, intraoral treatment of titanium
- XXL FG shanks facilitate the treatment of difficult to access implants
- Different shapes and sizes for every individual patient case
- Clean and smooth titanium surfaces



# Degranulation Kit **NEW**

## Diamond System for effective Bone Debridement

Das Degranulation Kit beinhaltet vier extra grobe, kugelförmige Diamantinstrumente in den Durchmessern 1,0, 2,5, 3,0 und 3,5 mm. Diese wurden speziell entwickelt, um ein schnelles und einfaches Knochendebridement zu ermöglichen. Mit Hilfe der Diamanten kann am Knochen anhaftendes Degranulationsgewebe schnell und einfach entfernt werden, ohne den umgebenden Knochen zu beschädigen, sodass anschließend eingesetztes Augmentationsmaterial direkt mit gesundem Knochen in Kontakt kommt. Damit ist das Degranulation Kit eine entscheidende Ergänzung im Degranulations-Prozess.

The Degranulation Kit contains four extra coarse, round diamond instruments with a diameters of 1.0, 2.5, 3.0 and 3.5 mm. The instruments have been specially developed to enable quick and easy bone debridement. With the help of these diamonds, degranulation tissue adhering to the bone can be removed quickly and easily without damaging the surrounding bone, so that subsequently inserted grafting material comes into direct contact with healthy bone. This makes the Degranulation Kit a crucial addition to the degranulation process.



Art.-No. DEG00

Diamantinstrumente  
Diamond instruments

Fig.	801LD*	801LD*	801LD*	801LD*
Shank <sup>1</sup>	206	206	206	206
Size <sup>2</sup>	010	025	030	035
* □ *	1.0	2.5	3.0	3.5

<sup>1</sup> 206 = RA XL    <sup>2</sup> Größter Arbeitsteildurchmesser in 1/10 mm    <sup>3</sup> Largest working part diameter in 1/10 mm

\* □ \* Außendurchmesser External diameter



## AUF EINEN BLICK

- Extra grobe, kugelförmige Diamanten für schnelles und einfaches Debridement
- Zuverlässiges Einsammeln des Degranulationsgewebes ohne Beschädigung des umgebenden Knochens
- Vier unterschiedliche Durchmesser für den Einsatz in allen Situationen
- Extra lange Instrumentenhäse für optimale Sicht auf den Operationsbereich
- Optimale Ergänzung im Degranulations-Prozess

## AT A GLANCE

- Extra coarse, round diamonds for quick and easy debridement
- Reliable removal of degranulation tissue without damaging the surrounding bone
- Four different diameters for use in all situations
- Extra long instrument necks for an optimal view of the operating area
- Optimal addition to the degranulation process



# MEISINGER

## Porcine Collagen Membrane

### Collagen Membrane from porcine Pericardium

MEISINGER's porcine Kollagenmembran ist eine natürliche Membran, die aus porcinem Perikard hergestellt wird. Das spezielle Herstellungsverfahren sorgt dafür, dass die mikroporöse, 3-lagige Struktur erhalten bleibt und keine Vernetzungschemikalien benötigt werden. Diese außergewöhnliche Struktur führt zu einer äußerst flexiblen Membran mit besonders hoher Zugfestigkeit.

Die porcine Kollagenmembran zeichnet sich durch ihre geschmeidige Handhabung, hohe Flexibilität und ideale Anpassungsfähigkeit aus. Sobald die Membran hydratisiert wird, verliert sie ihre ursprüngliche Form und wird flexibel, sodass sie sich optimal an alle Defektoberflächen anpasst. Da die Oberfläche der Membran auf beiden Seiten identisch ist, können beide Seiten gegen den Defekt platziert werden.

MEISINGER's porcine collagen membrane is a natural membrane made from porcine pericardium. The special manufacturing process ensures that the microporous, 3-layered architecture is preserved and no cross-linking chemicals are needed. This extraordinary structure leads to a very flexible membrane with particularly high tensile strength.

The porcine collagen membrane is characterized by its smooth handling, high flexibility and ideal adaptability. Once hydrated the membrane loses its original shape and becomes flexible, so that it optimally adapts to all defect surfaces. As the surface of the membrane is identical on both sides, both sides can be placed against the defect.

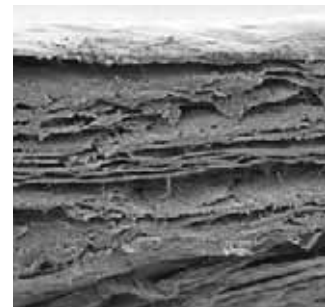

© Hager & Meisinger GmbH, Germany

Produkte sind in Originalgröße abgebildet!  
Products are shown in their original size!



Art.-No. MPC1520  
15 mm x 20 mm  
(1 membrane / box)



Art.-No. MPC1325  
13 mm x 25 mm  
(1 membrane / box)



Art.-No. MPC2030  
20 mm x 30 mm  
(1 membrane / box)



Art.-No. MPC3040  
30 mm x 40 mm  
(1 membrane / box)

### AUF EINEN BLICK

- Hergestellt aus porcinem Perikard
- Spezielle 3-lagige Struktur für hohe Zugfestigkeit
- Geschmeidige Handhabung
- Besonders hohe Flexibilität und ideale Anpassung an den Defekt
- Beide Seiten der Membran können gegen den Defekt platziert werden
- Resorptionszeit von etwa 26 Wochen

### AT A GLANCE

- Made of porcine pericardium
- Special, 3-layered architecture for high tensile strength
- Smooth handling
- Especially high flexibility and ideal adaption to the defect
- Both sides of the membrane can be placed against the defect
- Resorption time of about 26 weeks



# MEISINGER

## Bovine Collagen Membrane

### Typ 1 bovine Collagen Membrane

MEISINGER's bovine Kollagenmembran wird aus hochreinem Typ 1 Kollagen hergestellt, das aus boviner Achillessehne gewonnen wird. Ein großer Vorteil der bovinen Membranen ist ihr ideales Handling. Sie kombinieren hohe Flexibilität mit optimaler Stabilität. Dadurch sind sie flexibel und lassen sich leicht an jede Form anpassen und einfach platzieren. Gleichzeitig sind die stabil genug, ihre Form zu halten und nicht in den Defekt zu kollabieren. Die mehrlagige Struktur der Membranen ermöglicht eine Gewebeintegration in die äußere Schicht und verhindert den direkten Durchtritt von Bakterien und Epithelzellen. Die einzigartige Faserausrichtung sorgt für höchste Zugfestigkeit. So können die Membranen sicher durch Nähte oder Pins befestigt werden, ohne zu reißen. Dank der langen und planbaren Resorptionszeit von 26 bis 38 Wochen besteht kein Risiko von Partikelverlust infolge vorzeitiger Resorption.

MEISINGER's bovine collagen membrane is made from highly purified type 1 collagen derived from bovine achilles tendon. A great advantage of the bovine membranes is their ideal handling. They combine high flexibility with optimum stability. This makes them flexible, adaptable to any shape and easy to place. At the same time they are stable enough to hold their shape and not to collapse into the defect. The unique fiber orientation ensures maximum tensile strength. Thus, the membranes can be safely fixed by sutures or pins without tearing. Due to the long and predictable resorption time of 26 to 38 weeks, there is no risk of particle loss due to early resorption.

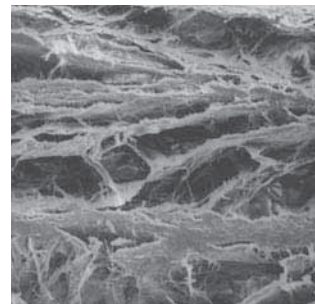

© Hager & Meisinger GmbH, Germany

Produkte sind in Originalgröße abgebildet!  
Products are shown in their original size!



Art.-No. MBC1520  
15 mm x 20 mm  
(2 membranes / box)



Art.-No. MBC2030  
20 mm x 30 mm  
(2 membranes / box)



Art.-No. MBC3040  
30 mm x 40 mm  
(2 membranes / box)

### AUF EINEN BLICK

- Lange Resorptionszeit von 26 bis 38 Wochen
- Ideales Handling
- Hohe Flexibilität zur einfachen Kammabdeckung
- Optimale Formstabilität
- Hohe Zugfestigkeit für die sichere Befestigung

### AT A GLANCE

- Long resorption time of 26 to 38 weeks
- Ideal handling
- High flexibility for easy ridge preservation
- Optimum dimensional stability
- High tensile strength for safe fixing



# MEISINGER dPTFE Membrane

## Micro-textured, high-density PTFE Membrane

MEISINGER's dPTFE Membranen bestehen aus hochdichtem PTFE mit einer Porengröße von weniger als  $0,3 \mu\text{m}$ . Damit ist die nicht resorbierbare Membran unempfindlich gegenüber Bakterien und ermöglicht ein Höchstmaß an Vorhersagbarkeit und Ästhetik. Beim Einsatz der dPTFE Membranen ist kein primärer Wundverschluss notwendig. Die exponierte PTFE-Membran kann nach mindestens 21 Tagen ohne chirurgischen Eingriff mit einer Pinzette entfernt werden, es ist keine zusätzliche Anästhesie erforderlich. Die hexagonalen Vertiefungen vergrößern die Oberfläche, was zu einer erhöhten Stabilität der Membran führt und die Zellanhaftung begünstigt ohne die Porosität zu erhöhen. Für optimale Ergebnisse sollte die Seite mit den Vertiefungen in Richtung des Weichgewebes platziert werden. Die Meisinger dPTFE Membranen können bei Bedarf zugeschnitten werden.

MEISINGER's dPTFE membranes are made of high-density PTFE with a pore size of less than  $0.3 \mu\text{m}$ . Thus, the non-absorbable membrane is insensitive to bacteria and allows a maximum of predictability and aesthetics. When using the dPTFE membranes, no primary wound closure is necessary. The exposed membrane can be removed with tweezers after at least 21 days without surgical intervention, no additional anesthesia is required. The hexagonal depressions are designed to increase the surface area, which leads to an increased stability of the membrane and favors cell adhesion without increasing the porosity. For best results, the side with the depressions should be placed in the direction of the soft tissue. The Meisinger dPTFE membranes can be cut to size as needed.

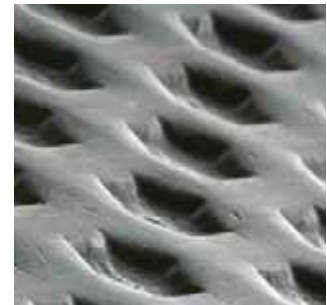

© Hager &amp; Meisinger GmbH, Germany

Produkte sind in Originalgröße abgebildet!  
Products are shown in their original size!

Insbesondere für die Augmentation nach Einzelzahnextraktionen:  
Especially for single tooth extraction site grafting:



Art.-No. MDP1224-1  
12 mm x 24 mm  
(1 membrane / box)



Art.-No. MDP1224  
12 mm x 24 mm  
(10 membranes / box)



Art.-No. MDP2530-1  
25 mm x 30 mm  
(1 membrane / box)



Art.-No. MDP2530  
25 mm x 30 mm  
(4 membranes / box)

## AUF EINEN BLICK

- Nicht resorbierbare Membran aus hochdichtem PTFE
- Höchstmaß an Vorhersagbarkeit und Ästhetik
- Kein primärer Wundverschluss notwendig
- Nicht-chirurgische Entfernung der Membran
- Hexagonale Vertiefungen der Oberfläche für hohe Stabilität
- Keine Störung der Wundheilung durch vorzeitige Resorption

## AT A GLANCE

- Non-absorbable membrane made of high-density PTFE
- Maximum of predictability and aesthetics
- No primary wound closure necessary
- Non-surgical removal of the membrane
- Hexagonal depressions of the surface for high stability
- No disruption of wound healing due to early resorption



# MEISINGER Titanium-Reinforced dPTFE Membrane

## Titanium-reinforced, high-density PTFE membrane

MEISINGER's Titanium-Reinforced-Membranen bestehen aus hochdichtem PTFE. In Kombination mit einer Titanverstärkung bieten die Membranen eine außerordentliche Formstabilität bei gleichzeitig optimaler Flexibilität. Daher eignen sich die Membranen im Rahmen der Kieferkammaugmentation insbesondere für die Therapie von 3- bis 4-wandigen Defekten. Die große Auswahl verschiedener Membranformen und -größen deckt eine Vielzahl unterschiedlicher Defekte ab und beschränkt die Notwendigkeit des Zuschnitts auf ein Minimum. Bei Bedarf können die Membranen jedoch optimal auf die erforderliche Form zugeschnitten werden. Die titanverstärkten Membranen sind erhältlich in den Stärken 150  $\mu\text{m}$  und 250  $\mu\text{m}$ .

MEISINGER's Titanium-Reinforced membranes are made of high density PTFE. In combination with titanium reinforcement, the membranes offer exceptional dimensional stability and optimum flexibility at the same time. Therefore, the membranes are particularly suitable for the treatment of 3- to 4-wall defects in the course of the alveolar ridge augmentation. The wide variety of membrane shapes and sizes covers a variety of different defects and minimizes the need for trimming. If necessary, however, the membranes can be optimally trimmed to the required shape. The titanium-reinforced membranes are available in thicknesses of 150  $\mu\text{m}$  and 250  $\mu\text{m}$ .



© Hager & Meisinger GmbH, Germany



## AUF EINEN BLICK

- Nicht resorbierbare Membran aus hochdichtem PTFE
- Feine Titanverstärkung aus Titan Grade I
- Optimale Kombination aus Flexibilität und Formstabilität
- Therapie von 3- bis 4-wandigen Defekten
- Große Auswahl verschiedener Membranformen
- Verfügbarkeit zwei verschiedener Membranstärken

## AT A GLANCE

- Non-absorbable membrane made of high-density PTFE
- Fine Titanium Reinforcement from Titanium Grade I
- Optimum combination of flexibility and dimensional stability
- Treatment of 3- to 4-wall defects
- Wide range of different membrane shapes
- Availability of two different membrane thicknesses



Für die Membranen auf dieser und der folgenden Seite gilt: Ti250 = 250 µm, Ti150 = 150 µm  
Generally applies to the membranes on this and the following page: Ti250 ≅ 250 µm, Ti150 ≅ 150 µm

### FORMEN MIT FIXIERUNGSPUNKTEN / SHAPES WITH FIXATION POINTS

Produkte sind in Originalgröße abgebildet!  
Products are shown in their original size!

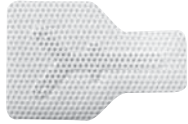

Art.-No. MTi2501725-1    Art.-No. MTi2501725-2  
Art.-No. MTi1501725-1    Art.-No. MTi1501725-2  
17 mm x 25 mm            17 mm x 25 mm  
(1 membrane / box)      (2 membranes / box)

Anwendung bei großen bukkalen Defekten.  
Designed for large buccal defects.

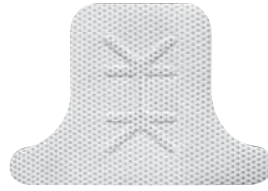

Art.-No. MTi2502536-1    Art.-No. MTi2502536-2  
Art.-No. MTi1502536-1    Art.-No. MTi1502536-2  
25 mm x 36 mm            25 mm x 36 mm  
(1 membrane / box)      (2 membranes / box)

Anwendung bei großen Extraktionsalveolen und bei begrenzten Kieferkammaugmentationen im anterioren Oberkieferbereich.  
Designed for large extraction sites and limited ridge augmentation in the anterior maxilla.



Art.-No. MTi2503041-1    Art.-No. MTi2503041-2  
Art.-No. MTi1503041-1    Art.-No. MTi1503041-2  
30 mm x 41 mm            30 mm x 41 mm  
(1 membrane / box)      (2 membranes / box)

Anwendung bei großen Knochendefekten, einschließlich Kieferkammaugmentationen im anterioren Oberkieferbereich.  
Designed for large bony defects, including ridge augmentation in the anterior maxilla.

### VIELSEITIGE RECHTECKIGE FORMEN / VERSATILE RECTANGULAR SHAPES

Produkte sind in Originalgröße abgebildet!  
Products are shown in their original size!



Art.-No. MTi2501224-1    Art.-No. MTi2501224-2  
Art.-No. MTi1501224-1    Art.-No. MTi1501224-2  
12 mm x 24 mm            12 mm x 24 mm  
(1 membrane / box)      (2 membranes / box)

Anwendung bei engen Extraktionsalveolen, insbesondere wenn eine oder mehrere Knochenwände fehlen.  
Designed for narrow single-tooth extraction sites, especially where one or more bony walls are missing.



Art.-No. MTi2501230-1    Art.-No. MTi2501230-2  
12 mm x 30 mm            12 mm x 30 mm  
(1 membrane / box)      (2 membranes / box)

Anwendung bei engen Extraktionsalveolen, insbesondere wenn eine oder mehrere Knochenwände fehlen.  
Designed for narrow single-tooth extraction sites, especially where one or more bony walls are missing.



Art.-No. MTi2502025-1    Art.-No. MTi2502025-2  
Art.-No. MTi1502025-1    Art.-No. MTi1502025-2  
20 mm x 25 mm            20 mm x 25 mm  
(1 membrane / box)      (2 membranes / box)

Anwendung bei großen Extraktionsalveolen und bei begrenzten Kieferkammaugmentationen. Anwendung bei großen bukkalen Defekten.  
Designed for grafting posterior extraction sites and limited ridge augmentation. Designed for large buccal defects.



Art.-No. MTi2502530-1    Art.-No. MTi2502530-2  
Art.-No. MTi1502530-1    Art.-No. MTi1502530-2  
25 mm x 30 mm            25 mm x 30 mm  
(1 membrane / box)      (2 membranes / box)

Anwendung bei Augmentationen großer Knochendefekte, einschließlich Kieferkammaugmentationen.  
Designed for grafting large bony defects, including ridge augmentation.



Art.-No. MTi2503040-1    Art.-No. MTi2503040-2  
Art.-No. MTi1503040-1    Art.-No. MTi1503040-2  
30 mm x 40 mm            30 mm x 40 mm  
(1 membrane / box)      (2 membranes / box)

Anwendung bei sehr großen Knochendefekten, einschließlich Kieferkammaugmentationen.  
Designed for very large bony defects, especially ridge augmentation.



Art.-No. MTi250304K-1    Art.-No. MTi250304K-2  
Art.-No. MTi150304K-1    Art.-No. MTi150304K-2  
30 mm x 40 mm            30 mm x 40 mm  
(1 membrane / box)      (2 membranes / box)

Anwendung bei sehr großen Knochendefekten, einschließlich Kieferkammaugmentationen.  
Designed for very large bony defects, especially ridge augmentation.

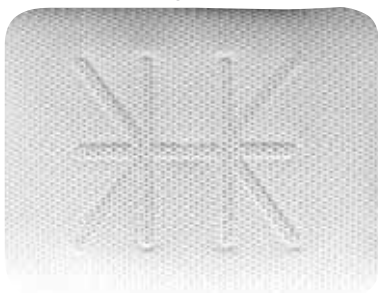

Art.-No. MTi2504050-1    Art.-No. MTi2504050-2  
Art.-No. MTi1504050-1    Art.-No. MTi1504050-2  
40 mm x 50 mm            40 mm x 50 mm  
(1 membrane / box)      (2 membranes / box)

Anwendung bei größten Knochendefekten, einschließlich Kieferkammaugmentationen.  
Designed for the largest bony defects, including ridge augmentation.





## INTERPROXIMALE FORMEN / INTERPROXIMAL SHAPES

Produkte sind in Originalgröße abgebildet!  
Products are shown in their original size!



Art.-No. MTi2501424-1 Art.-No. MTi2501424-2  
Art.-No. MTi1501424-1 Art.-No. MTi1501424-2  
14 mm x 24 mm 14 mm x 24 mm  
(1 membrane / box) (2 membranes / box)

**Anwendung bei Extraktionsalveolen, insbesondere wenn eine oder mehrere Knochenwände fehlen.**  
Designed for single-tooth extraction sites, especially where one or more bony walls are missing.



Art.-No. MTi2502438-1 Art.-No. MTi2502438-2  
Art.-No. MTi1502438-1 Art.-No. MTi1502438-2  
24 mm x 38 mm 24 mm x 38 mm  
(1 membrane / box) (2 membranes / box)

**Anwendung bei großen Extraktionsalveolen, einschließlich Kieferkammaugmentationen.**  
Designed for bony defects between adjacent teeth, including ridge augmentation.



Art.-No. MTi25038TC-1 Art.-No. MTi25038TC-2  
Art.-No. MTi15038TC-1 Art.-No. MTi15038TC-2  
38 mm x 38 mm 38 mm x 38 mm  
(1 membrane / box) (2 membranes / box)

**Anwendung bei großen Knochendefekten, einschließlich Kieferkammaugmentationen.**  
Designed for large bony defects between adjacent teeth, including ridge augmentation.



Art.-No. MTi25038D-1 Art.-No. MTi25038D-2  
Art.-No. MTi15038D-1 Art.-No. MTi15038D-2  
38 mm x 38 mm 38 mm x 38 mm  
(1 membrane / box) (2 membranes / box)

**Anwendung bei großen Knochendefekten, einschließlich distaler Verlängerung des posterioren Kieferkamms.**  
Designed for large bony defects, including distal extension of the posterior ridge.

## FORMEN FÜR PARODONTALE ANWENDUNG / PERIO SHAPES

Produkte sind in Originalgröße abgebildet!  
Products are shown in their original size!



Art.-No. MTi2501319-1 Art.-No. MTi2501319-2  
13 mm x 19 mm 13 mm x 19 mm  
(1 membrane / box) (2 membranes / box)

**Anwendung bei parodontalen Defekten im Frontzahnbereich.**  
Designed to fit periodontal defects in the anterior.



Art.-No. MTi2501318-1 Art.-No. MTi2501318-2  
13 mm x 18 mm 13 mm x 18 mm  
(1 membrane / box) (2 membranes / box)

**Anwendung bei parodontalen Defekten im Seitenzahnbereich.**  
Designed to fit periodontal defects in the posterior.



# Cytoplast™ Reinforced PTFE Mesh

## Micro-textured, high-density PTFE Membrane

Das einzigartige, kreisförmig makroporöse Design der Reinforced PTFE Meshes ermöglicht den direkten Kontakt zwischen Knochentransplantat und Periost, sodass die natürlich vorkommende Revaskularisierung und Infiltration von Zellen in das Knochentransplantat stattfinden kann. Die feine Titanverstärkung der Meshes dient dem Raumerhalt bei horizontalen und vertikalen Kieferkammaugmentationen. Die PTFE Meshes haben eine Dicke von 200 µm und passen sich leicht allen Gewebekonturen an.

The unique circular macroporous design of the Reinforced PTFE Meshes allows for direct contact between the bone graft and periosteum, allowing naturally occurring revascularization and infiltration of cells into the bone graft. The fine titanium frame maintains space essential for horizontal and vertical ridge augmentation. The PTFE Meshes have a thickness of 200 µm and easily conform to tissue contours.

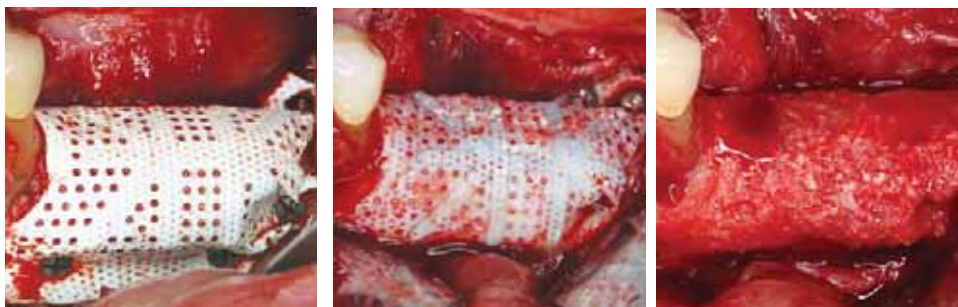

## AUF EINEN BLICK

- Nicht resorbierbare Membran aus hochdichtem PTFE
- Kreisförmige Makroporen für direkten Kontakt zwischen Knochentransplantat und Periost
- Feine Titanverstärkung für Raumerhalt bei horizontalen und vertikalen Kieferkammaugmentationen
- Höchstmaß an Vorhersagbarkeit und Ästhetik
- Keine Störung der Wundheilung durch vorzeitige Resorption

## AT A GLANCE

- Non-absorbable PTFE Mesh
- Circular macropores for direct contact between bone graft and periosteum
- Fine titanium frame maintains space for horizontal and vertical ridge augmentation
- Maximum of predictability and aesthetics
- No disruption of wound healing due to early resorption

## FORMEN MIT FIXIERUNGSPUNKTEN / SHAPES WITH FIXATION POINTS

Produkte sind in Originalgröße abgebildet!  
Products are shown in their original size!



Art.-No. RPM200BL  
17 mm x 25 mm  
(1 membrane / box)

Anwendung bei großen bukkalen Defekten.  
Designed for large buccal defects.



Art.-No. RPM200PST  
25 mm x 36 mm  
(1 membrane / box)

Anwendung bei großen Extraktionsalveolen und begrenzten Kieferkammaugmentationen im anterioren Oberkieferbereich.  
Designed for large extraction sites and limited ridge augmentation in the anterior maxilla.



Art.-No. RPM200PLT4  
12 mm x 24 mm  
(1 membrane / box)

Anwendung bei großen Knochendefekten, einschließlich Kieferkammaugmentationen im anterioren Oberkieferbereich.  
Designed for large bony defects, including ridge augmentation in the anterior maxilla.



## VIELSEITIGE RECHTECKIGE FORMEN / VERSATILE RECTANGULAR SHAPES

Produkte sind in Originalgröße abgebildet!  
Products are shown in their original size!



Art.-No. RPM200PS  
20 mm x 25 mm  
(1 membrane / box)

Anwendung bei großen Extraktionsalveolen und begrenzten Kieferkammaugmentationen.  
Designed for large extraction sites and limited ridge augmentation.



Art.-No. RPM200PL  
25 mm x 30 mm  
(1 membrane / box)

Anwendung bei großen Knochendefekten, einschließlich Kieferkammaugmentationen.  
Designed for large bony defects, including ridge augmentation.



Art.-No. RPM200XL  
30 mm x 40 mm  
(1 membrane / box)

Anwendung bei sehr großen Knochendefekten, einschließlich Kieferkammaugmentationen.  
Designed for very large bony defects, including ridge augmentation.



Art.-No. RPM200XLK  
30 mm x 40 mm  
(1 membrane / box)

Anwendung bei sehr großen Knochendefekten, einschließlich Kieferkammaugmentationen.  
Designed for very large bony defects, including ridge augmentation.



Art.-No. RPM200XLKM  
(Unterkiefer / Mandible)  
30 mm x 40 mm  
(1 membrane / box)

Anwendung bei sehr großen Knochendefekten, einschließlich Kieferkammaugmentationen im Unterkiefer. Hinweis: Der nicht-perforierte Teil ist für die Anwendung im lingualen Bereich.  
Designed for very large bony defects, including mandibular ridge augmentation. NOTE: Non-perforated region is designed for lingual aspect.



Art.-No. RPM200K2  
40 mm x 50 mm  
(1 membrane / box)

Anwendung bei größten Knochendefekten, einschließlich Kieferkammaugmentationen.  
Designed for the largest bony defects, including ridge augmentation.

## INTERPROXIMALE FORMEN / INTERPROXIMAL SHAPES

Produkte sind in Originalgröße abgebildet!  
Products are shown in their original size!



Art.-No. RPM200ATC  
24 mm x 38 mm  
(1 membrane / box)

Anwendung bei großen Extraktionsalveolen, einschließlich Kieferkammaugmentationen.  
Designed for large extraction sites, including ridge augmentation.



Art.-No. RPM200ATCM  
(Unterkiefer / Mandible)  
24 mm x 38 mm  
(1 membrane / box)

Anwendung bei großen Extraktionsalveolen, einschließlich Kieferkammaugmentationen im Unterkiefer. Hinweis: Der nicht-perforierte Teil ist für die Anwendung im lingualen Bereich.  
Designed for large extraction sites, including mandibular ridge augmentation. NOTE: Non-perforated region is designed for lingual aspect.



Art.-No. RPM200PTC  
38 mm x 38 mm  
(1 membrane / box)

Anwendung bei großen Knochendefekten, einschließlich Kieferkammaugmentationen.  
Designed for large bony defects, including ridge augmentation.

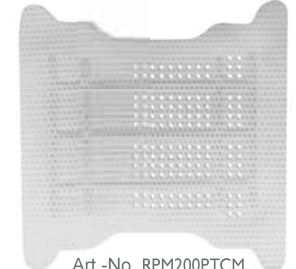

Art.-No. RPM200PTCM  
(Unterkiefer / Mandible)  
38 mm x 38 mm  
(1 membrane / box)

Anwendung bei großen Knochendefekten, einschließlich Kieferkammaugmentationen im Unterkiefer. Hinweis: Der nicht-perforierte Teil ist für die Anwendung im lingualen Bereich.  
Designed for large bony defects, including mandibular ridge augmentation. NOTE: Non-perforated region is designed for lingual aspect.

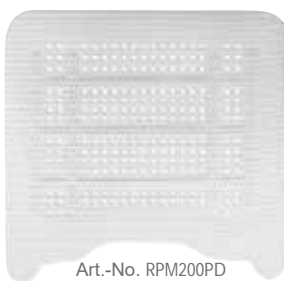

Art.-No. RPM200PD  
38 mm x 38 mm  
(1 membrane / box)

Anwendung bei großen Knochendefekten, einschließlich distaler Verlängerung des posterioren Kieferkamms.  
Designed for large bony defects, including distal extension of the posterior ridge.

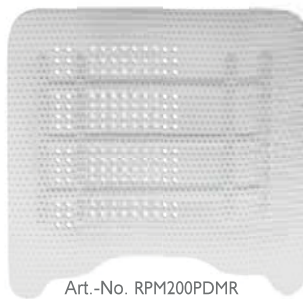

Art.-No. RPM200PDMR  
(Unterkiefer rechts / Mandible right)  
38 mm x 38 mm  
(1 membrane / box)

Anwendung bei großen Knochendefekten, einschließlich distaler Verlängerung des rechten posterioren Kieferkamms. Hinweis: Der nicht-perforierte Teil ist für die Anwendung im lingualen Bereich.  
Designed for large bony defects, including distal extension of the right posterior mandibular ridge. NOTE: Non-perforated region is designed for lingual aspect.

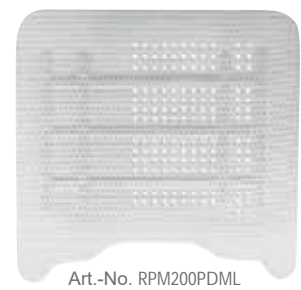

Art.-No. RPM200PDML  
(Unterkiefer links / Mandible left)  
38 mm x 38 mm  
(1 membrane / box)

Anwendung bei großen Knochendefekten, einschließlich distaler Verlängerung des linken posterioren Kieferkamms. Hinweis: Der nicht-perforierte Teil ist für die Anwendung im lingualen Bereich.  
Designed for large bony defects, including distal extension of the left posterior mandibular ridge. NOTE: Non-perforated region is designed for lingual aspect.



# Cytoplast™ RTMPlug, RTMFoam, RTMTape

Absorbable Wound Dressing I Type I & Type III bovine collagen

Produkte sind in Originalgröße abgebildet!  
Products are shown in their original size!

## RTMPLUG



Art.-No. RTMPLUG10  
10 mm x 20 mm  
(10 / box)

**Hinweis:** Die Resorptionszeit der Wundauflagen beträgt etwa 30 Tage.  
**Note:** Wound dressings will be essentially resorbed within 30 days.

## RTMFOAM



Art.-No. RTMFOAM10  
20 mm x 40 mm  
(Dicke/Thickness: 3 mm, 10 / box)

## RTMTAPE



Art.-No. RTMTAPE10  
25 mm x 75 mm  
(Dicke/Thickness: 1 mm, 10 / box)

## ANWENDUNGEN:

- Chirurgische Wunden
- Parodontale Wunden
- Extraktionsalveolen
- Dentale Wunden
- Mundgeschwüre (nicht-infiziert oder viral)
- Nahtstellen
- Verbrennungen
- Traumatische Wunden

## APPLICATIONS:

- Surgical wounds
- Periodontal surgical wounds
- Extraction sites
- Dental sores
- Oral ulcers (non-infected or viral)
- Suture sites
- Burns
- Traumatic wounds



# MEISINGER PTFE Suture

## Soft monofilament Suture

Die hohe Qualität des MEISINGER PTFE Nahtmaterials ermöglicht einen atraumatischen Wundverschluss nach dentalen Eingriffen. Die hochwertigen Nadeln bestehen aus rostfreiem Stahl und weisen eine sehr hohe Biegefestigkeit bei geringster Abnutzung auf. Scharf bleibende Nadeln sind das Ergebnis, auch nach mehrmaligem Einstechen. Die dadurch erreichte, konstant hohe Schneidleistung macht ein besonders gewebeschonendes Arbeiten möglich. Das Nahtmaterial besteht zu 100% aus medizinischem, bioinertem PTFE. Dank seiner glatten Oberfläche verhindert das Monofilament das Anhaften von Bakterien am Faden und sorgt für ein widerstandsfreies Gleiten durch das Gewebe. Das PTFE ist ein weiches, nicht resorbierbares Material mit gleichbleibender Zugstärke und ermöglicht dem Anwender so ein sehr präzises Arbeiten, die Planung mit einer definierten Einheilzeit und die patientenfreundliche Versorgung.

The high quality of the MEISINGER PTFE suture allows for atraumatic wound closure after dental procedures. The high-quality needles are made of stainless steel and have a very high bending strength with a minimum of wear. Sharp needles are the result, even after repeated piercing. The constant cutting performance allows for a particularly tissue-saving work. The suture is made of 100% medical grade bioinert PTFE. Thanks to its smooth surface, the monofilament prevents the adhesion of bacteria to the thread and ensures a resistance-free gliding through the tissue. The PTFE is a soft, non-resorbable material with consistent tensile strength, allowing the user to work very precisely, planning with a defined healing time, and patient-friendly care.



**Hinweis:** 12 Fäden / Box, Fadenlänge: 45 cm

**Note:** 12 Sutures / box, Suture length: 45 cm

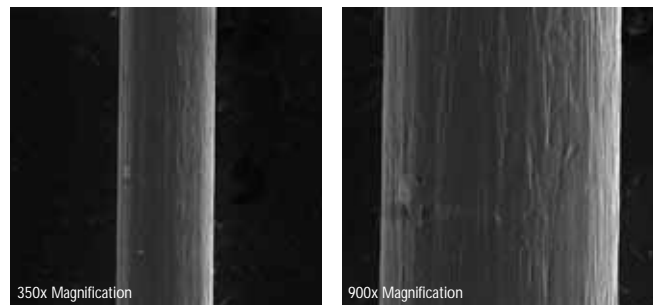

© Hager & Meisinger GmbH, Germany



### Art. No. MS2019

Faden: USP 2-0  
Nadel: 19 mm, 3/8-Kreis, außen schneidend  
Suture: USP 2-0  
Needle: 19 mm, 3/8 Circle, reverse cutting



### Art. No. MS3016B

Faden: USP 3-0  
Nadel: 16 mm, 3/8-Kreis, außen schneidend, schwarz beschichtet  
Suture: USP 3-0  
Needle: 16 mm, 3/8 Circle, reverse cutting, black coated



### Art. No. MS3019B

Faden: USP 3-0  
Nadel: 19 mm, 3/8-Kreis, außen schneidend, schwarz beschichtet  
Suture: USP 3-0  
Needle: 19 mm, 3/8 Circle, reverse cutting, black coated



### Art. No. MS4013

Faden: USP 4-0  
Nadel: 13 mm, 3/8-Kreis, außen schneidend  
Suture: USP 4-0  
Needle: 13 mm, 3/8 Circle, reverse cutting



### Art. No. MS5013

Faden: USP 5-0  
Nadel: 13 mm, 3/8-Kreis, außen schneidend  
Suture: USP 5-0  
Needle: 13 mm, 3/8 Circle, reverse cutting



### Art. No. MS3016

Faden: USP 3-0  
Nadel: 16 mm, 3/8-Kreis, außen schneidend  
Suture: USP 3-0  
Needle: 16 mm, 3/8 Circle, reverse cutting



### Art. No. MS3019

Faden: USP 3-0  
Nadel: 19 mm, 3/8-Kreis, außen schneidend  
Suture: USP 3-0  
Needle: 19 mm, 3/8 Circle, reverse cutting



### Art. No. MS4013TP

Faden: USP 4-0  
Nadel: 13 mm, 1/2-Kreis, Rundkörpernadel  
Suture: USP 4-0  
Needle: 13 mm, 1/2 Circle, Round-Bodied



### Art. No. MS4016

Faden: USP 4-0  
Nadel: 16 mm, 3/8-Kreis, außen schneidend  
Suture: USP 4-0  
Needle: 16 mm, 3/8 Circle, reverse cutting



### Art. No. MS5016

Faden: USP 5-0  
Nadel: 16 mm, 3/8-Kreis, außen schneidend  
Suture: USP 5-0  
Needle: 16 mm, 3/8 Circle, reverse cutting



# Pro-Fix™

## Precision Fixation System

Die Komponenten des Pro-Fix™ Precision Fixation Systems werden unter Einhaltung kleinster Toleranzen hergestellt und erlauben somit eine einfache Schraubenaufnahme und eine sichere Übertragung an die Operationsstelle. Zudem gewährleisten sie ein schnelles Eindringen in kortikalen Knochen. Alle Komponenten sind gemeinsam in einem Tray organisiert, um dem Anwender in effizienter Weise die Arbeit zu erleichtern. Im Tray können die Instrumente einfach sterilisiert und optimal aufbewahrt werden.

The Pro-Fix™ Precision Fixation System is manufactured to precise tolerances to ensure easy pick-up of screws, stable transfer to the surgical site and quick engagement in cortical bone. All kit components are labeled, organized, stored and sterilized together to simplify things for the surgeon and surgical team.



## Tecapro™ Storage Tray, Tecapro™ Storage Tray

Das autoklavierbare Tecapro™ Storage Tray ist clever konstruiert, um Instrumente und eine Vielzahl von Membran-, Knochen- und Tenting-Schrauben für die Transplantation von Kieferknochen aufzubewahren.

The autoclavable Tecapro™ Storage Tray is cleverly designed to store not only fixation instruments, but also a variety of membrane fixation, bone fixation, and tenting screws needed in dental bone grafting.

## Schrauben-Organizer, Screw Organizer Dial

Bis zu 100 Schrauben für Osteosynthese, Membranfixierung und Tenting können in einem speziellen Organizer aufbewahrt werden. Dieser ist so gekennzeichnet, dass die Schrauben leicht identifiziert, optimal gelagert und einfach nachbestellt werden können.

Up to 100 fixation screws – including bone fixation, membrane fixation, and tenting – may be stored in a built-in screw organizer dial designed and labeled for easy identification, easy storage and simple re-ordering.

## Griff und Schraubendreher, Driver Handle and Blade

Der Griff aus rostfreiem Stahl und der Kreuzschraubendreher sind miteinander kombinierbar und ermöglichen zusammen ein sicheres Aufnehmen der Schrauben und eine stabile Übertragung an die Operationsstelle.

The stainless steel driver handle and cruciform driver blade fit together to make up a drive system that ensures easy pick-up of screws and stable transfer to the surgical site.

## Einzelinstrumente, Individual Components

Die Instrumente sind universell in Kombination mit allen Pro-Fix™ Schrauben einsetzbar.

Blades work universally with all Pro-Fix™ screws.

Art-No.	Inhalt/Content	
PFT	Autoklavierbares Tecapro™ Storage Tray mit Schrauben-Organizer Autoclavable Tecapro™ Storage Tray with screw organizer dial	
PFDH	Schraubendreher-Griff aus rostfreiem Stahl Stainless steel driver handle	
PFDB	76 mm Kreuzschraubendreher 76 mm cruciform driver blade	
PFDB56	56 mm Kreuzschraubendreher 56 mm cruciform driver blade	
BI1001	1,2 mm Durchmesser RA-Pilotbohrer 1.2 mm diameter latch type pilot drill	
PFDBCA	RA-Schraubendreher (24 mm lang, 10 mm exponierte distale Länge) Contra angle blade (24 mm long, 10 mm exposed distal length)	



## Pro-Fix™ Membrane Fixation Screws



Die Pro-Fix™ Membrane Fixation Screws sind eine attraktive Alternative zur Verwendung von Tacs bei der Membranstabilisierung. Die sichere Aufnahme, der zuverlässige Halt während des Transports zur Operationsstelle und das einfache Platzieren machen die Membranfixierung mit Hilfe der Schrauben schnell und einfach.

Pro-Fix™ Membrane Fixation Screws are designed as an attractive alternative to using tacks for membrane stabilization. Easy pick-up, solid stability of the screw during transfer to the surgical site, and easy placement make membrane fixation fast and easy.

- Der Pro-Fix™ Kreuzschraubendreher passt sich sicher in den Schraubenkopf ein und bietet beim Einsetzen exzellente Schraubenstabilität
- Die Größe der Schrauben von 1,5 mm x 3,0 mm eignet sich perfekt zur Sicherung von Membranen und Netzen
- Das selbstschneidende Design der Schrauben erlaubt das Durchdringen des kortikalen Knochens, ohne dass die Nutzung eines Hammers oder die Durchführung einer Vorbohrung notwendig ist
- The Pro-Fix™ cruciform driver blade fits securely into the head of the screw and provides excellent screw stability upon placement
- 1.5 mm x 3.0 mm size is designed specifically for securing membranes and mesh
- The self-drilling design of each screw allows penetration through cortical bone without the use of a mallet or the need for drilling pilot holes

## Pro-Fix™ Membrane Fixation Kit (PFMK20)

### Inhalt

### Content

Art-No.	Anzahl/Quantity	Inhalt/Content	
PFT	1	Autoklavierbares Tecapro™ Storage Tray mit Schrauben-Organizer Autoclavable Tecapro™ Storage Tray with screw organizer dial	
PFDH	1	Schraubendreher-Griff aus rostfreiem Stahl Stainless steel driver handle	
PFDB	1	76 mm Kreuzschraubendreher 76 mm cruciform driver blade	
PFDB56	1	56 mm Kreuzschraubendreher 56 mm cruciform driver blade	
PFMF-5	20	1,5 mm x 3,0 mm selbstschneidende Schrauben aus Titanlegierung zur Membranfixierung 1.5 mm x 3.0 mm self-drilling titanium alloy membrane fixation screws	

### Weitere selbstschneidende Schrauben zur Membranfixierung

### Further self-drilling Membrane Fixation Screws

Art-No.	verpackt à packed à	Inhalt/Content	
PFMF-5	5	1,5 mm x 3,0 mm selbstschneidende Schrauben aus Titanlegierung zur Membranfixierung 1.5 mm x 3.0 mm self-drilling titanium alloy membrane fixation screws	



## Pro-Fix™ Tenting Screws



Pro-Fix™ Tenting Screws verfügen über eine selbstschneidende Spitze, einen polierten Hals und einen breiten Kopf, sodass sie bei horizontalen und vertikalen Knochenaugmentationen mit resorbierbaren und nicht-resorbierbaren Membranen der optimalen Raumerhaltung dienen.

Pro-Fix™ Tenting Screws are designed with a self-drilling tip, polished neck and broader head to maintain space under resorbable and non-resorbable membranes in horizontal and vertical bone regeneration procedures.

- Der Kopf mit 3,5 mm Durchmesser bietet eine große Oberfläche, um die Perforation oder das Einreißen der Membran zu verhindern
- Zur präzisen Raumerhaltung sind die Schrauben mit polierten Halsbereichen von 3 mm, 4 mm und 5 mm erhältlich
- 4 mm Gewindebereich zur Stabilisierung der Schrauben im Knochen
- Das selbstschneidende Design der Schrauben erlaubt das Durchdringen des kortikalen Knochens, ohne dass die Nutzung eines Hammers oder die Durchführung einer Vorbohrung notwendig ist
- 3.5 mm diameter head provides a broad surface area to help prevent membrane perforation or tearing
- Tenting screws are available with a 3 mm, 4 mm or 5 mm polished neck for precise space maintenance
- 4 mm threaded portion of each screw anchors into bone for stability
- The self-drilling design of each screw allows penetration through cortical bone without the use of a mallet or the need for drilling pilot holes

## Pro-Fix™ Tenting Kit (PFTK12)

### Inhalt

### Content

Art-No.	Anzahl Quantity	Inhalt Content	
PFT	1	Autoklavierbares Tecapro™ Storage Tray mit Schrauben-Organizer Autoclavable Tecapro™ Storage Tray with screw organizer dial	
PFDH	1	Schraubendreher-Griff aus rostfreiem Stahl Stainless steel driver handle	
PFDB	1	76 mm Kreuzschraubendreher 76 mm cruciform driver blade	
PFDB56	1	56 mm Kreuzschraubendreher 56 mm cruciform driver blade	
PFT3	4	1,5 mm x 3,0 mm selbstschneidende Tenting-Schrauben aus Titanlegierung, 3,0 mm polierter Hals + 4,0 mm Gewindebereich = 7 mm Gesamtlänge 1.5 mm x 3.0 mm self-drilling titanium alloy tenting screws, 3.0 mm polished neck + 4.0 mm threaded portion = 7 mm total length	
PFT4	4	1,5 mm x 4,0 mm selbstschneidende Tenting-Schrauben aus Titanlegierung, 4,0 mm polierter Hals + 4,0 mm Gewindebereich = 8 mm Gesamtlänge 1.5 mm x 4.0 mm self-drilling titanium alloy tenting screws, 4.0 mm polished neck + 4.0 mm threaded portion = 8 mm total length	
PFT5	4	1,5 mm x 5,0 mm selbstschneidende Tenting-Schrauben aus Titanlegierung, 5,0 mm polierter Hals + 4,0 mm Gewindebereich = 9 mm Gesamtlänge 1.5 mm x 5.0 mm self-drilling titanium alloy tenting screws, 5.0 mm polished neck + 4.0 mm threaded portion = 9 mm total length	

### Weitere selbstschneidende Tenting-Schrauben

### Further self-drilling Tenting Screws

Art-No.	verpackt à packed à	Inhalt Content	
PFT3	1	1,5 mm x 3,0 mm selbstschneidende Tenting-Schraube aus Titanlegierung, 3,0 mm polierter Hals + 4,0 mm Gewindebereich = 7 mm Gesamtlänge 1.5 mm x 3.0 mm self-drilling titanium alloy tenting screw, 3.0 mm polished neck + 4.0 mm threaded portion = 7 mm total length	
PFT3-5	5	1,5 mm x 3,0 mm selbstschneidende Tenting-Schrauben aus Titanlegierung, 3,0 mm polierter Hals + 4,0 mm Gewindebereich = 7 mm Gesamtlänge 1.5 mm x 3.0 mm self-drilling titanium alloy tenting screws, 3.0 mm polished neck + 4.0 mm threaded portion = 7 mm total length	
PFT4	1	1,5 mm x 4,0 mm selbstschneidende Tenting-Schraube aus Titanlegierung, 4,0 mm polierter Hals + 4,0 mm Gewindebereich = 8 mm Gesamtlänge 1.5 mm x 4.0 mm self-drilling titanium alloy tenting screw, 4.0 mm polished neck + 4.0 mm threaded portion = 8 mm total length	
PFT4-5	5	1,5 mm x 4,0 mm selbstschneidende Tenting-Schrauben aus Titanlegierung, 4,0 mm polierter Hals + 4,0 mm Gewindebereich = 8 mm Gesamtlänge 1.5 mm x 4.0 mm self-drilling titanium alloy tenting screws, 4.0 mm polished neck + 4.0 mm threaded portion = 8 mm total length	
PFT5	1	1,5 mm x 5,0 mm selbstschneidende Tenting-Schraube aus Titanlegierung, 5,0 mm polierter Hals + 4,0 mm Gewindebereich = 9 mm Gesamtlänge 1.5 mm x 5.0 mm self-drilling titanium alloy tenting screw, 5.0 mm polished neck + 4.0 mm threaded portion = 9 mm total length	
PFT5-5	5	1,5 mm x 5,0 mm selbstschneidende Tenting-Schrauben aus Titanlegierung, 5,0 mm polierter Hals + 4,0 mm Gewindebereich = 9 mm Gesamtlänge 1.5 mm x 5.0 mm self-drilling titanium alloy tenting screws, 5.0 mm polished neck + 4.0 mm threaded portion = 9 mm total length	
PFT8	1	1,5 mm x 8,0 mm selbstschneidende Tenting-Schraube aus Titanlegierung, 8,0 mm Vollgewindeschraube (Gesamtlänge 8 mm) 1.5 mm x 8.0 mm self-drilling titanium alloy tenting screw, 8.0 mm fully threaded tenting screw (8 mm total length)	
PFT10	1	1,5 mm x 10,0 mm selbstschneidende Tenting-Schraube aus Titanlegierung, 10,0 mm Vollgewindeschraube (Gesamtlänge 10 mm) 1.5 mm x 10.0 mm self-drilling titanium alloy tenting screw, 10.0 mm fully threaded tenting screw (10 mm total length)	





## Pro-Fix™ Bone Fixation Screws



Pro-Fix™ Bone Fixation Screws sind mit einem feinen, selbstschneidenden Gewinde ausgestattet, das den Schrauben eine hohe Stabilität verleiht und gleichzeitig das Drehmoment beim Einbringen reduziert. Das Gewinde der Schrauben verfügt über eine optimale Schneidengeometrie, die ein leichteres Einsetzen in harten Knochen ermöglicht. Die Schrauben werden in eine 1,2 mm vorgebohrte Pilotbohrung eingesetzt.

Pro-Fix™ Bone Fixation Screws are designed with finer pitched, self-tapping threads that give the screws greater clamping force while using less driver torque. The screws' threads are equipped with a cutting flute that allows for easier insertion into harder bone. The screws are placed into a 1.2 mm pre-drilled pilot hole.

- Das Kopfdesign ermöglicht es, die Schrauben bündig mit der Knochenoberfläche zu verschrauben
- Das feine Gewinde sorgt für eine erhöhte Stabilität der Schraube und reduziert gleichzeitig das Drehmoment beim Einbringen
- Die Osteosyntheseschrauben sind in den Längen 8 mm, 10 mm, 12 mm und 14 mm erhältlich
- Head design allows screw to be screwed down flush to bone surface leaving no gap between the screw's head and the bone
- Fine pitched threads give screw greater clamping force while using less driver torque
- Bone Fixation screws are available in 8 mm, 10 mm, 12 mm and 14 mm lengths

## Pro-Fix™ Bone Fixation Kit (PFBK12)

### Inhalt

### Content

Art-No.	Anzahl Quantity	Inhalt Content	
PFT	1	Autoklavierbares Tecapro™ Storage Tray mit Schrauben-Organizer Autoclavable Tecapro™ Storage Tray with screw organizer dial	
PFDH	1	Schraubendreher-Griff aus rostfreiem Stahl Stainless steel driver handle	
PFDB	1	76 mm Kreuzschraubendreher 76 mm cruciform driver blade	
PFDB56	1	56 mm Kreuzschraubendreher 56 mm cruciform driver blade	
BI1001	1	1,2 mm Durchmesser RA-Pilotbohrer 1.2 mm diameter latch type pilot drill	
PFB8	2	1,5 mm x 8,0 mm Osteosyntheseschrauben 1.5 mm x 8.0 mm bone fixation screws	
PFB10	4	1,5 mm x 10,0 mm Osteosyntheseschrauben 1.5 mm x 10.0 mm bone fixation screws	
PFB12	4	1,5 mm x 12,0 mm Osteosyntheseschrauben 1.5 mm x 12.0 mm bone fixation screws	
PFB14	2	1,5 mm x 14,0 mm Osteosyntheseschrauben 1.5 mm x 14.0 mm bone fixation screws	

### Weitere selbstschneidende Osteosyntheseschrauben

### Further self-tapping Bone Fixation Screws

Art-No.	verpackt à packed à	Inhalt Content	
PFB8	1	1,5 mm x 8,0 mm selbstschneidende Osteosyntheseschraube 1.5 mm x 8.0 mm self-tapping Bone Fixation Screw	
PFB8-5	5	1,5 mm x 8,0 mm selbstschneidende Osteosyntheseschrauben 1.5 mm x 8.0 mm self-tapping Bone Fixation Screws	
PFB10	1	1,5 mm x 10,0 mm selbstschneidende Osteosyntheseschraube 1.5 mm x 10.0 mm self-tapping Bone Fixation Screw	
PFB10-5	5	1,5 mm x 10,0 mm selbstschneidende Osteosyntheseschrauben 1.5 mm x 10.0 mm self-tapping Bone Fixation Screws	
PFB12	1	1,5 mm x 12,0 mm selbstschneidende Osteosyntheseschraube 1.5 mm x 12.0 mm self-tapping Bone Fixation Screw	
PFB12-5	5	1,5 mm x 12,0 mm selbstschneidende Osteosyntheseschrauben 1.5 mm x 12.0 mm self-tapping Bone Fixation Screws	
PFB14	1	1,5 mm x 14,0 mm selbstschneidende Osteosyntheseschraube 1.5 mm x 14.0 mm self-tapping Bone Fixation Screw	
PFB14-5	5	1,5 mm x 14,0 mm selbstschneidende Osteosyntheseschrauben 1.5 mm x 14.0 mm self-tapping Bone Fixation Screws	



# NanoBone®

Synthetic Bone Grafting Material | Bone Formation in a new Dimension



# NanoBone®

NanoBone® Katalog  
separat erhältlich  
NanoBone® Catalogue  
separately available

## AUF EINEN BLICK

## AT A GLANCE



### Synthetisches Knochenaufbaumaterial

NanoBone® ist frei von tierischen und menschlichen Bestandteilen und damit von jeglichem materialbedingten Kontaminationsrisiko. Im Rahmen der Patientenaufklärung können ethische Bedenken ausgeschlossen werden. Durch die hochtechnologischen Produktionsprozesse ist eine gleichbleibende Produktqualität sichergestellt.



### Synthetic bone grafting material

NanoBone® contains absolutely no human or animal ingredients so no material-related contamination risks and alleviates ethical concerns for patient consent. High-tech production processes ensure consistent and excellent quality.



### Vollständiges Remodelling

Aufgrund der besonderen Struktur nutzt NanoBone® das natürliche Remodelling. Osteoklasten bauen das Material in dem Maß ab, in dem Osteoblasten neuen Knochen bilden. Materialab- und Knochenaufbau sind somit aneinander gekoppelt. Das führt zu vorhersehbaren Ergebnissen und einem zuverlässigen Knochenlager.



### Complete remodelling

Thanks to its special structure, NanoBone® can be used for natural remodelling. Osteoclasts resorb the material as osteoblasts form new bone. Material resorption and bone formation are linked. This means predictable results and a reliable bone basis.



### Kontrollierte Osteoinduktion

NanoBone® ist osteokonduktiv und osteoinduktiv. Es dient somit nicht nur als Leitgerüst, sondern fördert aktiv die Knochenneubildung.



### Controlled osteoinduction

NanoBone® is osteoconductive and osteoinductive. In other words, it is not simply a scaffold: it actively promotes bone formation.



## NanoBone® | granulate

Fast and easy Application



Das **NanoBone® | granulate** steht entsprechend der Indikation in feiner und grober Körnung zur Verfügung.

**NanoBone® | granulate** is available in either fine or coarse granules to suit the indication.



Das Granulat kann mit Patientenblut oder steriler Kochsalzlösung angemischt werden. Von Herstellerseite wird ein Anmischen mit Blut empfohlen. Da das Material extrem hydrophil ist, saugt es sich sehr schnell voll.

The granulate can be mixed with the patient's blood or with a sterile saline solution. The manufacturer recommends mixing with blood. The material is extremely hydrophilic and fully absorbs the blood or saline solution quickly.



Nach dem Anmischen mit Blut bekommt das **NanoBone® | granulate** eine pastöse Konsistenz und lässt sich mit Anmischspatel oder Augmentationslöffel sehr gut applizieren.

When mixed with blood, **NanoBone® | granulate** takes on a paste-like consistency and can be easily applied with a spatula or augmentation spoon.

## NanoBone® | block

Synthetic Alternative to autologous Bone Blocks



Der **NanoBone® | block** wurde gemeinsam mit Anwendern als Alternative zum autologen Knochenblock entwickelt. Der Block wird im Set mit zwei Schrauben zur Fixierung geliefert.

**NanoBone® | block** was developed in partnership with users as an alternative to the autologous bone block. The block comes in a set with two screws for attachment.



Zur Anpassung an das Knochenlager kann der Block mit rotierenden oder schabenden Instrumenten bearbeitet werden. Im Lieferset ist zusätzlich eine spezielle OP-Anleitung enthalten. The block can be shaped with rotating or scraping tools to adapt it to the bone. The specific surgery instructions are included with the set.



# NanoBone® | QD

Ideal bone healing in combination with perfect handling



Die **NanoBone® QD** verbindet den Vorteil der schnellen Regeneration mit dem des einfachen Handlings. **NanoBone® QD** combines rapid regeneration with ease of use.



„Ready to use“ kann das Material direkt aus dem Applikator in den Defekt eingebracht werden. Ein zusätzliches Anmischen ist nicht mehr nötig, so wird Zeit und Material gespart. The material is ready to use - apply straight from the applicator to the defect. Mixing is not required, saving time and material.

## AUF EINEN BLICK

### Der Applikator

- „Ready to use“ direkte Anwendung aus dem Applikator
- Einfache, intuitive Anwendung
- Genaue Platzierung des **NanoBone® QD** Materials
- Kontrollierte und genaue Portionierung
- Erlaubt kleine Zugänge zum Applikationsort (Außendurchmesser des Applikators nur 8 mm)
- Ermöglicht retrograde Befüllung von Knochendefekten
- Versorgung von schwierig zugänglichen Knochendefekten dank langem Applikator

### The Material

- Formbar und an den Defekt anpassbar
- Starker Zusammenhalt des Materials (Kohäsion)
- Klebt auch am Knochen (Adhäsion)
- Auch in wässriger Umgebung und stark blutenden Wunden stabil
- Kontrollierte Osteoinduktion

## AT A GLANCE

### The applicator

- "Ready to use" direct application from the applicator
- Easy, intuitive use
- Precise placement of the **NanoBone® QD** material
- Controlled and exact portioning
- Allows for small approaches to the application site (outer diameter of the applicator just 8 mm)
- Allows for retrograde filling of bone defects
- Difficult to access bone defects treated due to the long applicator

### The material

- Shapeable and adaptable to the defect
- Strong cohesion of the material
- Sticks to the bone (adhesion)
- Stable also in aqueous environment and profusely bleeding wounds
- Controlled osteoinduction

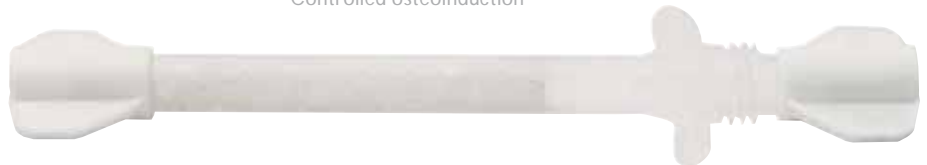

## Anwendungsempfehlung, Application information



Der hintere Sicherheitsverschluss wird durch Drehen gelöst und anschließend abgezogen. The back safety lock is released by turning and then removed.



Der Kolben wird von hinten in den Applikator eingesetzt und anschließend sorgfältig nach vorne bis zum Material geschoben. The piston is inserted into the applicator from behind and then pushed forward up to the material.



Der vordere Sicherheitsverschluss wird durch Drehen gelöst und anschließend abgezogen. The front safety lock is released by turning and then removed.



NanoBone® QD (39% Silica / 61% Hydroxylapatit)		206 m <sup>2</sup> innere Oberfläche/internal surface area		
Art-No.	Inhalt/Content (1x)	Anwendungsempfehlung/Recommended applications <sup>1</sup>		
23P074	3 x 0,25 ml		<ul style="list-style-type: none"> <li>• Extraktionsalveolen (Frontzahn)</li> <li>• Implantatanlagerungen</li> <li>• Periimplantitis</li> <li>• Parodontale Defekte</li> <li>• Wurzelspitzenresektion</li> </ul>	<ul style="list-style-type: none"> <li>• Extraction alveoli (anterior tooth)</li> <li>• Augmentation around implants</li> <li>• Peri-implantitis</li> <li>• Periodontal defects</li> <li>• Apicoectomy</li> </ul>
23P075	3 x 0,5 ml		<ul style="list-style-type: none"> <li>• Extraktionsalveolen</li> <li>• Implantatanlagerungen</li> <li>• Periimplantitis</li> <li>• Parodontale Defekte</li> <li>• Zystenauffüllung</li> <li>• Wurzelspitzenresektion</li> </ul>	<ul style="list-style-type: none"> <li>• Extraction alveoli</li> <li>• Augmentation around implants</li> <li>• Peri-implantitis</li> <li>• Periodontal defects</li> <li>• Filling cysts</li> <li>• Apicoectomy</li> </ul>
200070	1 x 1,0 ml		<ul style="list-style-type: none"> <li>• Extraktionsalveolen</li> <li>• Wurzelspitzenresektion</li> <li>• Sinusbodenelevation (je Implantat ca. 0,6 ml)</li> </ul>	<ul style="list-style-type: none"> <li>• Extraction alveoli</li> <li>• Apicoectomy</li> <li>• Sinus floor elevation (ca. 0.6 ml per implant)</li> </ul>
200071	1 x 2,5 ml		<ul style="list-style-type: none"> <li>• Sinusbodenelevation (je Implantat ca. 0,6 ml)</li> <li>• Zystenauffüllung</li> </ul>	<ul style="list-style-type: none"> <li>• Sinus floor elevation (ca. 0.6 ml per implant)</li> <li>• Filling cysts</li> </ul>

NanoBone®   block (39% Silica / 61% Hydroxylapatit)		206 m <sup>2</sup> innere Oberfläche/internal surface area		
Art-No.	Inhalt/Content (1x)	Anwendungsempfehlung/Recommended applications <sup>1</sup>		
200023	(5 x 10 x 15 mm) (inkl. 2 x Osteosyntheseschrauben) (incl. 2 x osteosynthesis screws)		<ul style="list-style-type: none"> <li>• Knochenaufbau bei lateralen Knochendefekten</li> <li>• Kieferkammerverbreiterung</li> </ul>	<ul style="list-style-type: none"> <li>• Reconstruction for lateral bone defects</li> <li>• Enlargement of the alveolar bone ridge</li> </ul>

Osteosyntheseschrauben/Osteosynthesis Screws			
Art-No.	Inhalt/Content (2x)	Länge/Length	
TCTT5			L: 10.0 mm

Spiralbohrer/Twist Drill		Beschreibung/Description	
Art-No.			
TC203		<ul style="list-style-type: none"> <li>• Spiralbohrer für Osteosyntheseschrauben (TCTT5)</li> <li>• Twist drill for osteosynthesis screws (TCTT5)</li> </ul>	

Schraubendreher - Schraubhalter/Screwdriver - Screw holder		Beschreibung/Description	
Art-No.			
TL0T1		<ul style="list-style-type: none"> <li>• Schraubendreher für Osteosyntheseschrauben (TCTT5)</li> <li>• Screwdriver for osteosynthesis screws (TCTT5)</li> </ul>	
31053		<ul style="list-style-type: none"> <li>• Schraubendreher für Osteosyntheseschrauben (TCTT5)</li> <li>• Screwdriver for osteosynthesis screws (TCTT5)</li> </ul>	

NanoBone®   granulate fein/fine, Ø 0,6 mm (24% Silica / 76% Hydroxylapatit)		84 m <sup>2</sup> innere Oberfläche/internal surface area		
Art-No.	Inhalt/Content (1x)	Anwendungsempfehlung/Recommended applications <sup>1</sup>		
200001	1 x 0,6 ml		<ul style="list-style-type: none"> <li>• Sinusbodenelevation (je Implantat ca. 0,6 ml)</li> <li>• Extraktionsalveolen (Frontzahnbereich, prämolare)</li> <li>• Implantatanlagerungen</li> <li>• Periimplantitis</li> <li>• Parodontale Defekte</li> <li>• Zystenauffüllung</li> <li>• Wurzelspitzenresektion</li> </ul>	<ul style="list-style-type: none"> <li>• Sinus floor elevation (ca. 0.6 ml per implant)</li> <li>• Extraction alveoli (anterior tooth region, premolar)</li> <li>• Augmentation around implants</li> <li>• Peri-implantitis</li> <li>• Periodontal defects</li> <li>• Filling cysts</li> <li>• Apicoectomy</li> </ul>
200002	5 x 0,6 ml			
200003	1 x 1,2 ml		<ul style="list-style-type: none"> <li>• Extraktionsalveolen (molar)</li> <li>• Sinusbodenelevation (je Implantat ca. 0,6 ml)</li> <li>• Zystenauffüllung</li> </ul>	<ul style="list-style-type: none"> <li>• Extraction alveoli (molar)</li> <li>• Sinus floor elevation (ca. 0.6 ml per implant)</li> <li>• Filling cysts</li> </ul>
200004	5 x 1,2 ml			
200005	1 x 2,4 ml		<ul style="list-style-type: none"> <li>• Sinusbodenelevation (je Implantat ca. 0,6 ml)</li> <li>• Zystenauffüllung</li> </ul>	<ul style="list-style-type: none"> <li>• Sinus floor elevation (ca. 0.6 ml per implant)</li> <li>• Filling cysts</li> </ul>
200006	5 x 2,4 ml			
200025	1 x 5,0 ml		<ul style="list-style-type: none"> <li>• Zweiseitige Sinusbodenelevation</li> </ul>	<ul style="list-style-type: none"> <li>• Two-sided sinus floor elevation</li> </ul>

NanoBone®   granulate grob/coarse, Ø 1,0 mm (24% Silica / 76% Hydroxylapatit)		84 m <sup>2</sup> innere Oberfläche/internal surface area		
Art-No.	Inhalt/Content (1x)	Anwendungsempfehlung/Recommended applications <sup>1</sup>		
200007	1 x 1,2 ml		<ul style="list-style-type: none"> <li>• Extraktionsalveolen (molar)</li> <li>• Sinusbodenelevation (je Implantat ca. 0,6 ml)</li> <li>• Zystenauffüllung</li> </ul>	<ul style="list-style-type: none"> <li>• Extraction alveoli (molar)</li> <li>• Sinus floor elevation (ca. 0.6 ml per implant)</li> <li>• Filling cysts</li> </ul>
200008	5 x 1,2 ml			
200009	1 x 2,4 ml		<ul style="list-style-type: none"> <li>• Sinusbodenelevation (je Implantat ca. 0,6 ml)</li> <li>• Zystenauffüllung</li> </ul>	<ul style="list-style-type: none"> <li>• Sinus floor elevation (ca. 0.6 ml per implant)</li> <li>• Filling cysts</li> </ul>
200010	5 x 2,4 ml			
200026	1 x 5,0 ml		<ul style="list-style-type: none"> <li>• Zweiseitige Sinusbodenelevation</li> </ul>	<ul style="list-style-type: none"> <li>• Two-sided sinus floor elevation</li> </ul>

<sup>1</sup> Die benötigte Menge des Materials ist immer abhängig von der klinischen Situation, der Größe des Defektes und den anatomischen Gegebenheiten.  
The quantity of material required always depends on the clinical situation, the size of the defect, and the anatomical conditions.



# Easy-Clean Scissors NEW

## Surgical Scissors for easy and safe processing

Die MEISINGER Easy-Clean Scheren aus hochwertigem Edelstahl lassen sich ganz einfach vollständig auseinandernehmen und wieder zusammensetzen. Rückstände unter dem Scharnier können so vollständig entfernt werden – für eine rückstandsfreie Aufbereitung\*. Für die Demontage muss die Schere nur im rechten Winkel geöffnet und der obere Teil der Schere um ca. 45 Grad angehoben werden. Darüber hinaus verfügen die Scheren über eine schwarze Beschichtung, die mittels PVD Verfahren (vakuumbasierte Beschichtung) aufgebracht wird. Dank dieser schwarzen Beschichtung verfügen die Produkte insbesondere über eine hohe Härte und Langlebigkeit. Außerdem werden störende Lichtreflexe reduziert und ein blendfreies Arbeiten ermöglicht.

The MEISINGER Easy-Clean Scissors made of high-quality stainless steel can be easily and completely disassembled and put back together again. Residues below the hinge can be completely removed – for a residue-free processing\*. For dismantling, the scissors only need to be opened at a right angle. Then the upper part of the scissors is lifted briefly. In addition, the scissors have a black coating that is applied using PVD procedure (vacuum-based coating). Thanks to this black coating the products reach high hardness and durability. Furthermore, disturbing light reflections are reduced, and glare-free work is possible.



Art.-No. CM01S

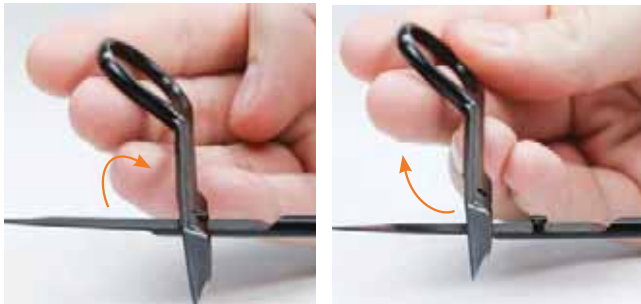

Fig.	CM001	CM002
Name	Schere / Scissor	Schere / Scissor
Length mm	120 (1:2)	130 (1:2)



## AUF EINEN BLICK

- Chirurgische Scheren aus hochwertigem Edelstahl
- Einfache vollständige Demontage für eine rückstandsfreie Aufbereitung\*
- Schwarze Beschichtung für hohe Härte und Langlebigkeit sowie blendfreies Arbeiten
- Scheren in zwei verschiedenen Ausführungen

## AT A GLANCE

- Surgical scissors made of high-quality stainless steel
- Easy and complete dismantling for residue-free processing\*
- Black coating for high hardness and durability as well as glare-free work
- Scissors in two different versions

\* Entsprechend der vorgeschriebenen Aufbereitungsverfahren nach EN ISO 17664 in correspondence with required processing procedures according to EN ISO 17664.



# Mikrochirurgische Instrumente/ Microsurgical Instruments

Schwarz beschichtet / mattierte Oberfläche  
Black Coated / Matte Finish



Fig.	TM0	TM1	TM2	TM3	TM4	TM5
Name	Nadelhalter gerade Needle holder straight	Nadelhalter gebogen Needle holder curved	Schere gerade Scissors straight	Schere gebogen Scissors curved	Pinzette gerade Forceps straight	Pinzette gebogen Forceps curved
Length mm	173.0	179.0	180.0	179.0	173.0	172.0

# Raspatorien/Raspatories



Fig.	HI009	HI010	HI011	HI012	HI013
Name	Raspatorium Raspatory	Raspatorium Raspatory	Raspatorium Raspatory	Raspatorium Raspatory	Raspatorium Raspatory
Length mm	182.0	178.0	178.0	170.0	192.0





# Handinstrumente/Manual instruments



Fig.	HI070	HI073	HI074	BR001	TL9
Name	Hammer Hammer	Meißel Chisel	Meißel Chisel	Knochenring Pinzette Bone Ring Tweezer	Schere Scissors
Length mm	195.0	157.0	157.0	166.0	116.0



# Ratschen/Ratchets

## Ratsche Ratchet

Diese Ratsche wurde konzipiert, um Drehmomente bis zu 70 Ncm zu übertragen. Zerlegbar zur einfachen und sicheren Reinigung.

This ratchet was designed to transfer turning moments up to 70 Ncm. May be disassembled for simple and safe cleaning.



Art.-No. CARA4

## Universelle Drehmoment-Ratsche Universal Torque Ratchet

Drehmoment-Ratsche zum Arbeiten mit definiertem Drehmoment. In Blockierstellung lassen sich sowohl für das Eindrehen als auch für das Ausdrehen Drehmomente übertragen, welche z.B. für das Einbringen von Implantaten notwendig sind.

Torque ratchet for working with defined torque. In blocking position, torques for both the insertion and the loosening of screws can be transmitted, e.g. for the insertion of implants.

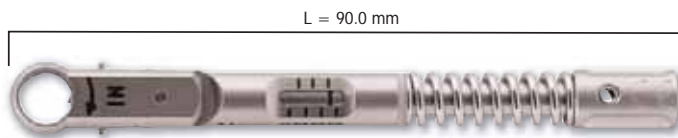

Art.-No. CA0RA

## Biegestab-Drehmomentratsche Bending Rod Torque Ratchet

**NEW**

Ratsche zum Arbeiten in Drehmomentfunktion und in blockierter Funktion. In der Drehmomentfunktion erfolgt der Einsatz unter Benutzung des Biegestabs, über den erreichte Drehmomente zwischen 10 und 70 Ncm abgelesen werden können. In der blockierten Position ermöglicht die Ratsche die Übertragung eines größeren Drehmoments, beispielsweise beim Einsetzen von Implantaten oder beim Lösen von Verbindungen.

Ratchet for working in torque function and in blocked function. In torque function the application takes place using the bending rod, from which torques between 10 and 70 Ncm can be read. In blocked function, the ratchet enables a greater torque to be transmitted, for example when inserting implants or loosening connections.

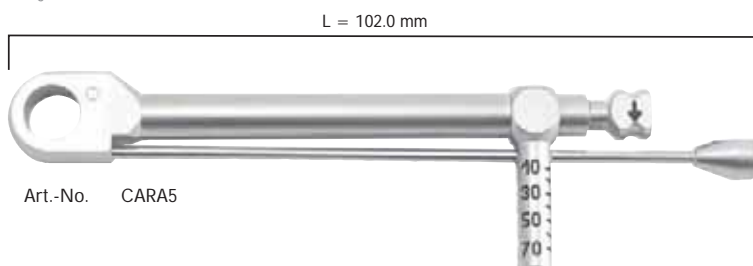

Art.-No. CARA5



# Chirurgieinstrumente/Surgery Instruments

MEISINGER bietet für die Mund-, Kiefer- und Gesichtschirurgie eines der umfangreichsten Programme im Bereich der Chirurgiebohrer, Chirurgiefräser und Trepäne an. Die optimierten Spezialkonstruktionen der Instrumente garantieren einen sicheren Einsatz und die schnelle Erreichung der gewünschten Arbeitsergebnisse.

MEISINGER offers one of the most extensive programs in the area of the Surgical Round Drills, Surgical Cutters, and Trephines. The optimized special construction of the instruments guarantee a safe application and fast achievement for the desired working result.

## Chirurgiefräser aus Hartmetall

Surgical Cutters of Tungsten Carbide

Die besondere, schnittfreundige und effiziente Sägeverzahnung und der gezielt ausgerichtete Drillwinkel ermöglichen ein breites Einsatzgebiet der Instrumente im Rahmen der oralen Kieferchirurgie. The special, easy-cutting and efficient saw toothing and the specifically selected angle of twist allow a wide field of application of the instruments within the field of oral surgery.

### HM 33IL

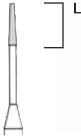



Fig.	Schaft / Shank	Ref.-Nr. / Ref.-No.		5
		L mm		5,5
		<b>US-No.</b>		700XXL
HM 33IL	RA L	500 <b>205</b> 415 007		010
	FG XL	500 <b>316</b> 415 007		010



Implantationsbohrer | Implant bur

### HM 33T







Fig.	Schaft / Shank	Ref.-Nr. / Ref.-No.		2
		L mm		5,2
HM 33T	HP	500 <b>104</b> 415 296		016
	RA L	500 <b>205</b> 415 296		016



### HM 34IL

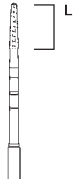



Fig.	Schaft / Shank	Ref.-Nr. / Ref.-No.		5
		L mm		6,0
HM 34IL	FG XXL	500 <b>317</b> 415 007		012



Implantationsbohrer | Implant bur

### HM 151

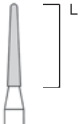



Fig.	Schaft / Shank	Ref.-Nr. / Ref.-No.		2
		L mm		10,8
HM 151	FG XL	500 <b>316</b> 199 295		016
HM 151	FG XXL	500 <b>317</b> 199 295		016



### HM 152







Fig.	Schaft / Shank	Ref.-Nr. / Ref.-No.		2
		L mm		9,0
HM 152	FG L	500 <b>315</b> 210 295		014



### HM G152







Fig.	Schaft / Shank	Ref.-Nr. / Ref.-No.		2
		L mm		9,1
HM G152	FG L	504 <b>315</b> 210 295		016



### HM 161

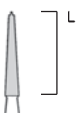



Fig.	Schaft / Shank	Ref.-Nr. / Ref.-No.		2
		L mm		11,0
HM 161	HP	500 <b>104</b> 408 295		018
	RA L	500 <b>205</b> 408 295		018
	FG XL	500 <b>316</b> 408 295		018



### HM 161RX







Fig.	Schaft / Shank	Ref.-Nr. / Ref.-No.		2
		L mm		11,0
HM 161RX	HP	500 <b>104</b> 408 296		018
	RA L	500 <b>205</b> 408 296		018
	RA XL	500 <b>206</b> 408 296		018
	FG XL	500 <b>316</b> 408 296		018



Chirurgische Fräser, kreuzverzahnt | Surgical cutters, x-cut

### HM 162







Fig.	Schaft / Shank	Ref.-Nr. / Ref.-No.		2
		L mm		11,0
HM 162	HP	500 <b>104</b> 408 297		016
	RA L	500 <b>205</b> 408 297		016
	RA XL	500 <b>206</b> 408 297		016
	FG XL	500 <b>316</b> 408 297		016





## HM 162A

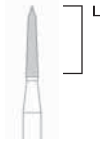

Fig.	Schaft / Shank	Ref.-Nr. / Ref.-No.		2
		L mm		9,0
HM 162A	HP	500 <b>104</b> 408 298		016
	RA	500 <b>204</b> 408 298		016
	FG	500 <b>314</b> 408 298		016



## HM 162SL



Fig.	Schaft / Shank	Ref.-Nr. / Ref.-No.		2
		L mm		8,0
HM 162SL	HP	500 <b>104</b> 408 338		014
	FG	500 <b>314</b> 408 338		014



## HM 162ST

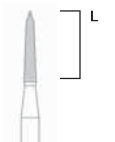

Fig.	Schaft / Shank	Ref.-Nr. / Ref.-No.		5
		L mm		9,0
HM 162ST	HP	500 <b>104</b> 408 337		016
	RA	500 <b>204</b> 408 337		016
	FG	500 <b>314</b> 408 337		016



## HM 162SX

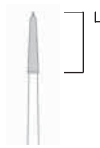

Fig.	Schaft / Shank	Ref.-Nr. / Ref.-No.		2
		L mm		8,0
HM 162SX	FG	500 <b>314</b> 413 338		014



## HM 163

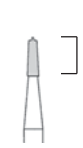

Fig.	Schaft / Shank	Ref.-Nr. / Ref.-No.		2
		L mm		5,0
HM 163	HP	500 <b>104</b> 406 297		014



## HM 163A

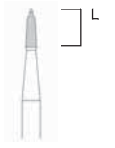

Fig.	Schaft / Shank	Ref.-Nr. / Ref.-No.		2
		L mm		5,0
HM 163A	HP	500 <b>104</b> 406 298		014



## HM 164

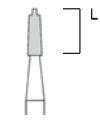

Fig.	Schaft / Shank	Ref.-Nr. / Ref.-No.		2
		L mm		6,0
HM 164	HP	500 <b>104</b> 407 297		018



## HM 165

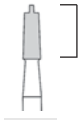

Fig.	Schaft / Shank	Ref.-Nr. / Ref.-No.		2
		L mm		7,0
HM 165	HP	500 <b>104</b> 408 297		023



## HM 166

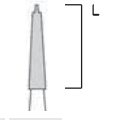

Fig.	Schaft / Shank	Ref.-Nr. / Ref.-No.		2
		L mm		11,0
HM 166	HP	500 <b>104</b> 409 297		021
	RA L	500 <b>205</b> 409 297		021



## HM 166A

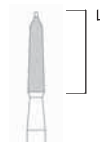

Fig.	Schaft / Shank	Ref.-Nr. / Ref.-No.		2
		L mm		11,0
HM 166A	HP	500 <b>104</b> 409 298		021



## HM 166ST

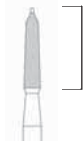

Fig.	Schaft / Shank	Ref.-Nr. / Ref.-No.		2
		L mm		11,0
HM 166ST	HP	500 <b>104</b> 409 337		021



## HM 166RX

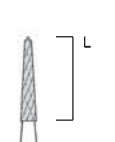

Fig.	Schaft / Shank	Ref.-Nr. / Ref.-No.		2
		L mm		11,0
HM 166RX	HP	500 <b>104</b> 409 296		021
	RA L	500 <b>205</b> 409 296		021
	RA XL	500 <b>206</b> 409 296		021



Chirurgische Fräser, kreuzverzahnt | Surgical cutters, x-cut



### HM 167



Fig.	Schaft / Shank	Ref.-Nr. / Ref.-No.	📄	2
		L mm		11,0
HM 167	HP	500 <b>104</b> 410 297		023
	RA L	500 <b>205</b> 410 297		023



### HM 254



Fig.	Schaft / Shank	Ref.-Nr. / Ref.-No.	📄	2
		L mm		6,0
HM 254	HP	500 <b>104</b> 415 296		012
	FG XXL	500 <b>317</b> 415 296		012



### HM 254E





Fig.	Schaft / Shank	Ref.-Nr. / Ref.-No.	📄	2
		L mm		6,0
HM 254E	RA L	500 <b>205</b> 415 298		012



### HM 254LE



Fig.	Schaft / Shank	Ref.-Nr. / Ref.-No.	📄	2
		L mm		6,0
HM 254LE	FG	500 <b>314</b> 415 299		012



### HM 408M



Fig.	Schaft / Shank	Ref.-Nr. / Ref.-No.	📄	2
		L mm		10,0
HM 408M	HP	500 <b>104</b> 409 338		016
	FG XL	500 <b>316</b> 409 338		016



## Chirurgie-Kugelfräser aus Hartmetall

Surgical round drill of tungsten carbide

### HM 1S

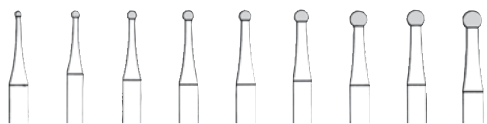



Fig.	Schaft / Shank	Ref.-Nr. / Ref.-No.	📄	5	5	5	5	5	5	5	5	5
		US-No.		<b>1S</b>	<b>2S</b>	<b>3S</b>	<b>4S</b>	<b>5S</b>	<b>6S</b>	<b>7S</b>	<b>8S</b>	<b>10S</b>
HM 1S	RA	500 <b>204</b> 001 003		008	010	012	014	016	018	021	023	027
	RA L	500 <b>205</b> 001 003			010	012	014	016	018	021	023	
	FG	500 <b>314</b> 001 003		008	010	012	014	016	018	021	023	



### HM 1T



Fig.	Schaft / Shank	Ref.-Nr. / Ref.-No.	📄	2
HM 1T	HP	500 <b>104</b> 697 291		023
	RA L	500 <b>205</b> 697 291		023



### HM 141

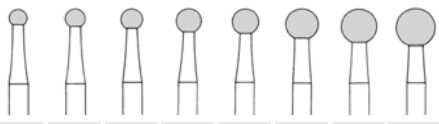



Fig.	Schaft / Shank	Ref.-Nr. / Ref.-No.	📄	2	2	2	2	2	2	2	2
HM 141	HP	500 <b>104</b> 001 291		023	025	027	031	035	040	045	050
	RA L	500 <b>205</b> 001 291		023							



Hartmetall, 6 Schneiden | Tungsten carbide, 6 blades



## HM 141A

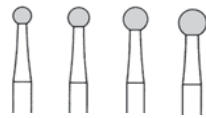

Fig.	Schaft / Shank	Ref.-Nr. / Ref.-No.		2	2	2	2
HM 141A	HP	500 <b>104</b> 001 298		023	027	031	035
	RA L	500 <b>205</b> 001 298					035
	RA XL	500 <b>206</b> 001 298		023	027	031	035



Hartmetall, quergebverzahnt, 8-10 Schneiden | Tungsten carbide, cross cut, 8-10 blades

## HM 141F

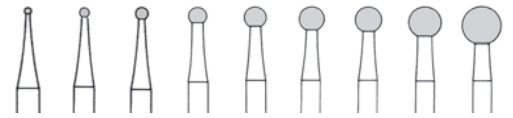

Fig.	Schaft / Shank	Ref.-Nr. / Ref.-No.		2	2	2	2	2	2	2	2	2	2
HM 141F	HP	500 <b>104</b> 001 251		010	014	018	023	027	031	035	040	050	
	RA L	500 <b>205</b> 001 251		010	014	018	023	027	031	035	040	050	
	RA XL	500 <b>206</b> 001 251		010	014	018	023	027	031	035	040	050	



Hartmetall fein, 8-10 Schneiden | Tungsten carbide fine, 8-10 blades

## HM 141AS



NEW

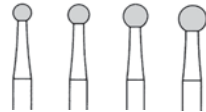

Fig.	Schaft / Shank	Ref.-Nr. / Ref.-No.		2	2	2	2
HM 141AS	HP	500 <b>104</b> 001 300		023	027	031	035



## Hartmetallfinierer

Tungsten Carbide Finishing Burs

### HM 379

HM 379U

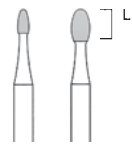

Fig.	Schaft / Shank	Ref.-Nr. / Ref.-No.		5	5	
				L mm	3,1	4,2
				US-No.	7404	7408
HM 379	FGXXL	500 <b>317</b> 277 072		014	023	
HM 379U	FGXXL	500 <b>317</b> 277 032		014	023	



### HM 48L

HM 48LU

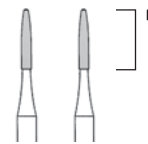

Fig.	Schaft / Shank	Ref.-Nr. / Ref.-No.		5	5	
				L mm	8,0	8,0
HM 48L	FGXXL	500 <b>317</b> 249 072		014	023	
HM 48LU	FGXXL	500 <b>317</b> 249 032		014	023	



## Chirurgiefräser aus Stahl

Surgical Cutters of Steel

### 161

STAHL / STEEL

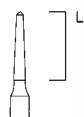

Fig.	Schaft / Shank	Ref.-Nr. / Ref.-No.		2	
				L MM	9,0
161	FG XL	310 316 408 295		016	



### 162 162RF

STAHL / STEEL

EDELSTAHL / STAINLESS STEEL

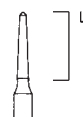

Fig.	Schaft / Shank	Ref.-Nr. / Ref.-No.		2	
				L MM	9,0
162	RA L	310 205 408 297		016	
	FG XL	310 316 408 297		016	
162RF	HP	330 104 408 297		016	
	RA L	330 205 408 297		016	
	FG XL	330 316 408 297		016	



### 163RF

EDELSTAHL / STAINLESS STEEL

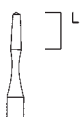

Fig.	Schaft / Shank	Ref.-Nr. / Ref.-No.		2	
				L MM	5,0
163RF	HP	330 104 406 297		014	





**164RF** Edelstahl / stainless steel

Fig.	Schaft / Shank	Ref.-Nr. / Ref.-No.		2
			L mm	6,0
164RF	HP	330 104 407 297		018



**165RF** Edelstahl / stainless steel

Fig.	Schaft / Shank	Ref.-Nr. / Ref.-No.		2
			L mm	7,0
165RF	HP	330 104 408 297		023
	RA L	330 205 408 297		023



**166** Stahl / steel  
**166RF** Edelstahl / stainless steel

Fig.	Schaft / Shank	Ref.-Nr. / Ref.-No.		2
			L mm	10,0
166	RA L	310 205 409 297		021
166RF	HP	330 104 409 297		021



**167RF** Edelstahl / stainless steel

Fig.	Schaft / Shank	Ref.-Nr. / Ref.-No.		2
			L mm	10,0
167RF	HP	330 104 410 297		023



**168** Stahl / steel  
**168RF** Edelstahl / stainless steel

Fig.	Schaft / Shank	Ref.-Nr. / Ref.-No.		1
			L mm	22,0
168	HP L	310 105 411 297		023
168RF	HP L	330 105 411 297		023

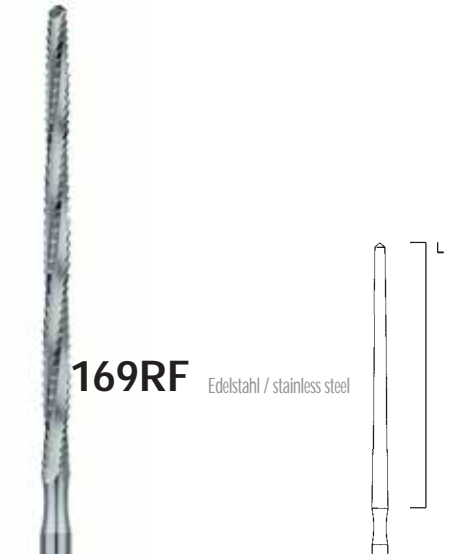

**169RF** Edelstahl / stainless steel

Fig.	Schaft / Shank	Ref.-Nr. / Ref.-No.		1
			L mm	35,0
169RF	HP XL	330 106 412 297		023



<sup>1</sup> Nur für RF. Für Instrumente aus Werkzeugstahl ist Vorbehandlung notwendig. Siehe hierzu Hinweise zur Aufbereitung.  
<sup>1</sup> Only for RF. Pre-treatment is necessary for instruments made of tool steel. See the notes on preparation.

## Chirurgie-Kugelfräser aus rostfreiem Stahl

Surgical round drill of stainless Steel

Grober Allport Fräser für weiche Strukturen | Coarse Allport bur for soft structures



**141RF** Edelstahl / stainless steel

Fig.	Schaft / Shank	Ref.-Nr. / Ref.-No.		2	2	2	2	2	2
141RF	HP	330 104 001 291		023	025	027	031	035	040
	RA XL	330 206 001 291		023					



6 Schneiden | 6 cutting edges

## Stahlbohrer

Steel burs

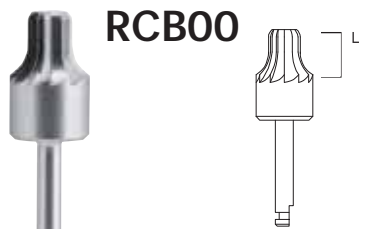

**RCB00**

Schaft / Shank	Fig.	RCB00
RA L		075
	L mm	6.0
		4.2
		7.5
		2



Minimaldurchmesser Minimal diameter

Außendurchmesser External diameter



# Diamantierte Chirurgieinstrumente

Surgical Diamond Instruments

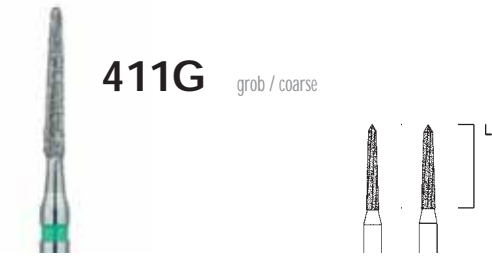

**411G** grob / coarse

Fig.	Schaft / Shank	Ref.-Nr. / Ref.-No.		2	2
				L mm	
				11,0	11,0
<b>411G</b>	FG L	806 <b>315</b> 411 534		016	018



Chirurgische Fräser, diamantiert | Diamond surgical cutters



**801** mittel / medium

801H super grob / super coarse  
801G grob / coarse  
801F fein / fine  
801C extra fein / extra fine

Fig.	Schaft / Shank	Ref.-Nr. / Ref.-No.		5	5	5	2
<b>801</b>	HP	806 <b>104</b> 001 524		023*	027*	033*	050*
	RA	806 <b>204</b> 001 524		023	027	033	050
<b>801H</b>	HP	806 <b>104</b> 001 544					050*
	RA	806 <b>204</b> 001 544					050
<b>801G</b>	HP	806 <b>104</b> 001 534		023*		033*	050*
	RA	806 <b>204</b> 001 534					050
<b>801F</b>	RA	806 <b>204</b> 001 514		023		033	
<b>801C</b>	HP	806 <b>104</b> 001 504		023*			
	RA	806 <b>204</b> 001 504		023			



Sinus Präparation | Sinus preparation



**801LD** mittel / medium  
super grob / super coarse

**NEW**

Fig.	Schaft / Shank	Ref.-Nr. / Ref.-No.		2	2	2	2
<b>801LD</b>	RAXL	806 <b>206</b> 697 534		010			
<b>801LD</b>	RAXL	806 <b>206</b> 697 534			025	030	035

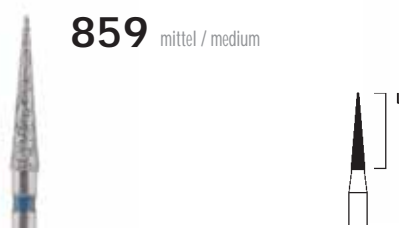

**859** mittel / medium

Fig.	Schaft / Shank	Ref.-Nr. / Ref.-No.		5
				L mm
				10,0
<b>859</b>	RA	806 <b>204</b> 166 524		018

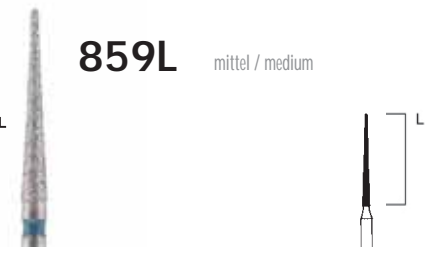

**859L** mittel / medium

Fig.	Schaft / Shank	Ref.-Nr. / Ref.-No.		5
				L mm
				12,0
<b>859L</b>	RA	806 <b>204</b> 167 524		010



**231DC** extra fein / extra fine

Fig.	Schaft / Shank	Ref.-Nr. / Ref.-No.		1	1	1
				L mm		
				0,3	0,3	0,3
<b>231DC</b>	HP	806 <b>104</b> 064 504		070	100	
	RA	806 <b>204</b> 064 504		070*	100*	130*



Osteotomie-Säge für Chirurgie | Osteotomy saw for surgery

\* im Saw Basic Kit 7150 enthalten \* contained in the Saw Basic Kit 7150



**915DM** mittel / medium

**NEW**

Fig.	Schaft / Shank	Ref.-Nr. / Ref.-No.		1
				L mm
				0,25
<b>915D</b>	HP	806 <b>104</b> 35M 524		220
	unmounted	806 <b>900</b> 35M 524		220

Super flexibel | Super flexible







# Vorkörner

Initial Burs



**186RF** Edelstahl / stainless steel

Fig.	Schaft / Shank	Ref.-Nr. / Ref.-No.	5
		L mm	12,0
<b>186RF</b>	HP	330 <b>104</b> 684 377	018
	RA	330 <b>204</b> 684 377	018



Vorkörner, Stahl rostfrei | Initial bur, stainless steel



**187RF** Edelstahl / stainless steel

Fig.	Schaft / Shank	Ref.-Nr. / Ref.-No.	5
		L mm	19,0
<b>187RF</b>	RA	330 <b>204</b> 685 377	018



Vorkörner mit Stop, Stahl rostfrei | Initial bur with Stop, stainless steel



**188RF** Edelstahl / stainless steel

Fig.	Schaft / Shank	Ref.-Nr. / Ref.-No.	2	2
		L mm	17,3	27,3
<b>188RF</b>	RAXL	330 <b>206</b> 686 378	014	
	RAXXL	330 <b>207</b> 686 378		014



! According to Prof. Dr. Fouad Khoury



**202RF** Edelstahl / stainless steel

Fig.	Schaft / Shank	Ref.-Nr. / Ref.-No.	5	5
		L mm	5,6	6,2
<b>202RF</b>	RA XL	330 <b>206</b> 455 361	008	010



# Spiralbohrer

Twist Drills



**203RF** Edelstahl / stainless steel

Fig.	Schaft / Shank	Ref.-Nr. / Ref.-No.	2	2	2	2
		L mm	7,0	7,0	9,0	9,0
<b>203RF</b>	RA L	330 <b>205</b> 417 364	006	008	009	011



! According to Dr. Istvan Urban



**203S** Edelstahl / stainless steel

Fig.	Schaft / Shank	Ref.-Nr. / Ref.-No.	2
		L mm	3,0
<b>203S</b>	RA	330 <b>204</b> 449 336	012



Spiralbohrer mit Stop zum Dekortikalisieren | Twist Drill with Stop for decorticating



# Pilotbohrer

Pilot burs

Pilotbohrer, L=11 mm  
Pilot burs, L=11 mm

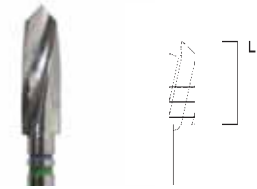

Schaft / Shank	Fig.	<b>G2001</b>
RA L	┌┐	3,40
	☒	1



Pilotbohrer, L=12 mm  
Pilot burs, L=12 mm

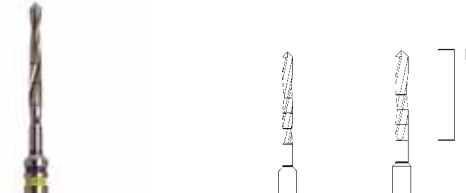

Schaft / Shank	Fig.	<b>A2001</b>	<b>B2001</b>
RA L	┌┐	1,30	1,60
	☒	1	1



Pilotbohrer, L=15 mm  
Pilot burs, L=15 mm



Schaft / Shank	Fig.	<b>A1001</b>	<b>B1001</b>	<b>C1001</b>	<b>D1001</b>	<b>E1001</b>	<b>F1001</b>
RA XL	┌┐	1,00	1,30	1,50	1,80	2,00	2,50
	☒	1	1	1	1	1	1



# Trepane

Trephines

**229** Edelstahl / stainless steel

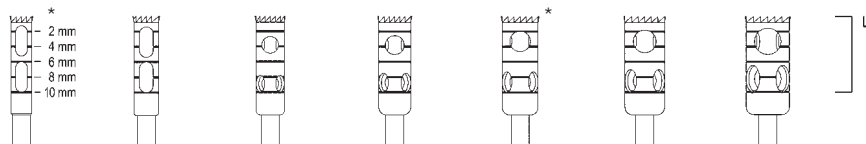

Fig.	Schaft / Shank	Ref.-Nr. / Ref.-No.	☒	1	1	1	1	1	1	1
	L mm			10,0	10,0	10,0	10,0	10,0	10,0	10,0
	┌┐			3,00	3,50	4,00	4,50	5,00	5,50	6,00
	┌┐			2,00	2,50	3,00	3,50	4,00	4,50	5,00
<b>229</b>	RA L	<b>330 205 486 001</b>		020	025	030	035	040	045	050

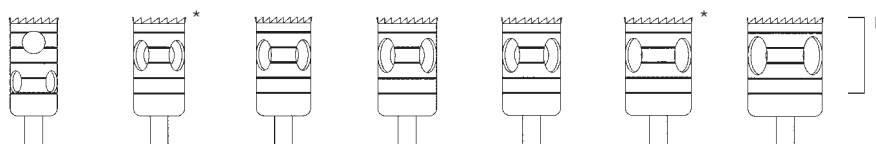

Fig.	Schaft / Shank	Ref.-Nr. / Ref.-No.	☒	1	1	1	1	1	1	1
	L mm			10,0	10,0	10,0	10,0	10,0	10,0	10,0
	┌┐			6,50	7,00	7,50	8,00	8,50	9,00	10,00
	┌┐			5,50	6,00	6,50	7,00	7,50	8,00	9,00
<b>229</b>	RA L	<b>330 205 486 001</b>		055	060	065	070	075	080	090

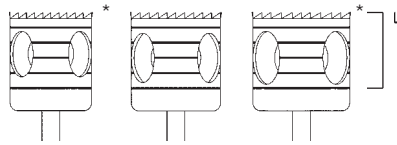

Fig.	Schaft / Shank	Ref.-Nr. / Ref.-No.		1	1	1	
				L mm	10,0	10,0	10,0
					11,00	12,00	13,00
					10,00	11,00	12,00
<b>229</b>	RA L	330 205 486 001		100	110	120	



\* im Trephine Basic Kit 7120 enthalten  
\* contained in the Trephine Basic Kit 7120

Nenngröße = Innendurchmesser | nominal size = internal diameter



## 229L Edelstahl / stainless steel

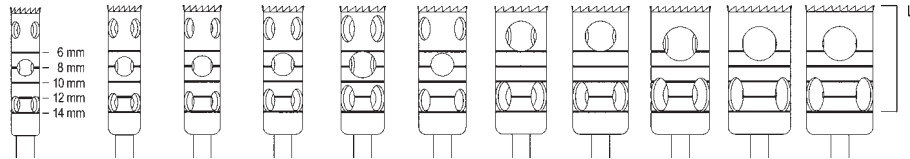

Fig.	Schaft / Shank	Ref.-Nr. / Ref.-No.		1	1	1	1	1	1	1	1	1	1
				L mm	14,0	14,0	14,0	14,0	14,0	14,0	14,0	14,0	14,0
					4,00	4,50	5,00	5,50	6,00	6,50	7,00	7,50	8,00
					3,00	3,50	4,00	4,50	5,00	5,50	6,00	6,50	7,00
<b>229L</b>	RA L	330 205 555 001		030	035	040	045	050	055	060	065	070	075



## 229XL Edelstahl / stainless steel

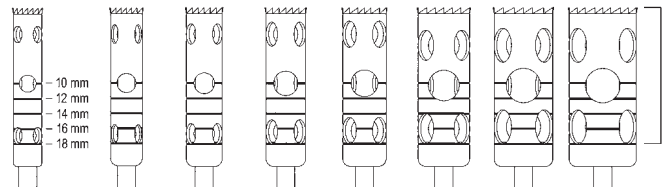

Fig.	Schaft / Shank	Ref.-Nr. / Ref.-No.		1	1	1	1	1	1	1
				L mm	18,0	18,0	18,0	18,0	18,0	18,0
					4,00	4,50	5,00	5,50	6,00	7,00
					3,00	3,50	4,00	4,50	5,00	6,00
<b>229XL</b>	RA L	330 205 556 001		030	035	040	045	050	060	070



## 224RF Edelstahl / stainless steel

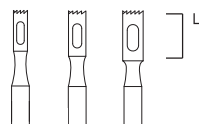

Fig.	Schaft / Shank	Ref.-Nr. / Ref.-No.		2	2	2	
				L mm	5,4	6,0	6,6
					1,85	2,3	2,7
					1,4	1,8	2,1
<b>224RF</b>	HP	330 104 485 001		018	023	027	



## 227RF Edelstahl / stainless steel

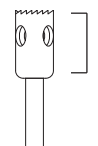
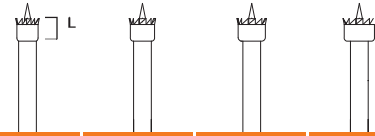

Fig.	Schaft / Shank	Ref.-Nr. / Ref.-No.		2	
				L mm	9,0
					5,0
					4,0
<b>227RF</b>	HP	330 104 485 001		050	





### 230KH\*



Schaft / Shank	Fig.	230KH	230KH	230KH	230KH
RA		021	025	029	033
L mm		2,0	2,0	2,0	2,0
		3,1	3,5	3,9	4,3
		2,1	2,5	2,9	3,3
		1	1	1	1



Vorkörner Trepane | Initial bur trephines



### 229KH\*

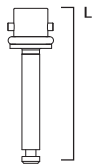

Schaft / Shank	Fig.	229KH
RA		000
L mm		20,5
		-
		-
		1



Innengekühlter Trepan-Schaft | Internally cooled trepan shank



### 229KH\*

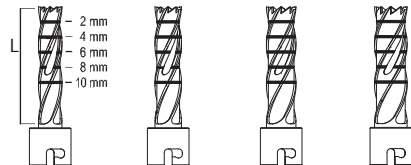

Schaft / Shank	Fig.	229KH	229KH	229KH	229KH
unmontiert / unmounted		021	025	029	033
L mm		15,5	15,5	15,5	15,5
		3,1	3,5	3,9	4,3
		2,1	2,5	2,9	3,3
		1	1	1	1



Innengekühlte Trepan-Arbeitsteile | Internally cooled trepan work parts

! Technology by Dr. Bernd Giesenhagen



### 229FS

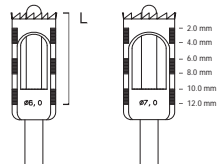

Schaft / Shank	Fig.	229FS	229FS
RA L		060	070
L mm		12,0	12,0
		6,0	7,0
		5,0	6,0
		1	1

## Schleimhautstanzen

Tissue punches



### 225

Edelstahl / stainless steel

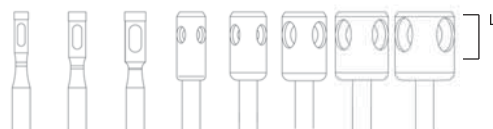

Fig.	Schaft / Shank	Ref.-Nr. / Ref.-No.		2	2	2	1	1	1	1	1
	L mm			5,3	4,5	4,9	6,0	6,0	6,0	6,0	6,0
				1,85	2,3	2,7	3,7	4,7	5,7	6,7	7,7
				1,4	1,8	2,1	3,0	4,0	5,0	6,0	7,0
225	HP	330 104 485 373		014	018	021					
	RA	330 204 485 373					030*	040*	050*	060*	070*



\* im Punch Basic Kit 7140 enthalten  
\* contained in the Punch Basic Kit 7140



# Spreader

## Spreaders

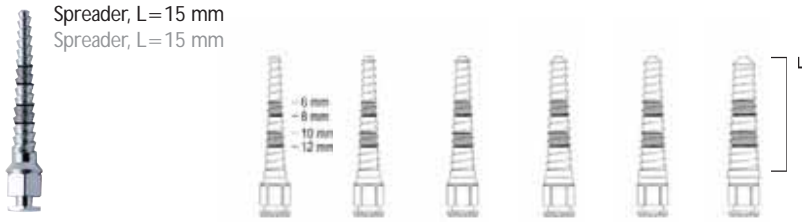

Fig.	A1005	B1005	C1005	D1005	E1005	F1005
	2,70	2,90	3,10	3,30	3,50	4,00
	1,43	1,64	1,84	2,05	2,26	2,79
	1	1	1	1	1	1

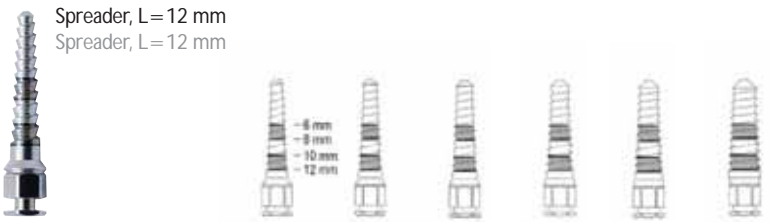

Fig.	A2005	B2005	C2005	D2005	E2005	F2005
	2,70	2,90	3,10	3,30	3,50	4,00
	1,70	1,91	2,12	2,33	2,54	3,06
	1	1	1	1	1	1



Fig.	G2005	H2005
	4,50	5,00
	3,65	4,17
	1	1

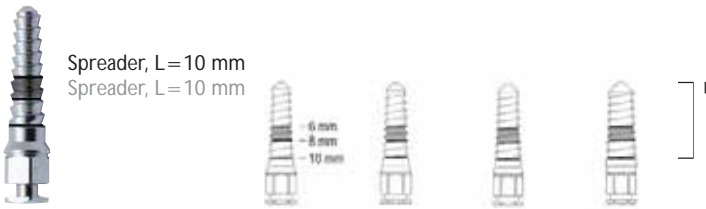

Fig.	C3005	D3005	E3005	F3005
	3,10	3,30	3,50	4,00
	2,30	2,51	2,72	3,24
	1	1	1	1



# Horizontal Spreader

## Horizontal spreaders



Fig.	VCD35
Width mm	3.5
Length mm	9.75
Height mm	10.6
Lifting Height mm	Max.
	5.0



Fig.	VCD50
Width mm	6.0
Length mm	9.75
Height mm	10.6
Lifting Height mm	Max.
	5.0



Fig.	VCD85
Width mm	8.5
Length mm	9.75
Height mm	10.6
Lifting Height mm	Max.
	5.0





# Gingivatrimmer

Gingiva trimmer

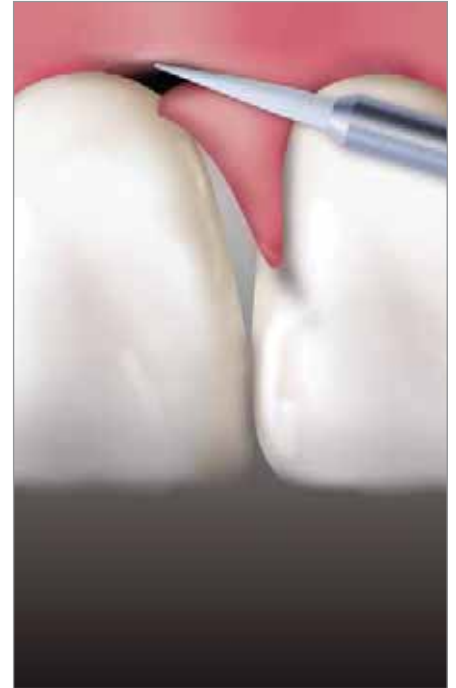

Die MEISINGER Gingivatrimmer dienen der Anwendung in der dentalen Schleimhautchirurgie. Sie wurden speziell zur vielseitigen und schonenden Behandlung des Zahnfleischgewebes entwickelt. Das Arbeitsteil besteht aus besonders hochwertigem und stabilem Zirkonoxid. Der Anwendungsschwerpunkt der MEISINGER Gingivatrimmer liegt in der sicheren und schonenden Entfernung von unerwünschtem Granulationsgewebe und hyperplastischer Gingiva (Papillektomie) – auch an schwer zugänglichen Stellen. Weiter finden die Trimmer Anwendung in der Erweiterung des Sulcus nach Kronenstumpfpräparation, zur bestmöglichen Darstellung der Präparationsgrenze und der Erstellung eines exakten Abdrucks. Auch sind die Gingivatrimmer insbesondere geeignet zur gewebeschonenden Freilegung verdeckt eingeeilter Implantate und zum Einsatz in der Parodontosebehandlung. Die Anwendung erfolgt dabei ohne Kühlung, sodass die entstehende Rotationsenergie zur Gewebemodulation genutzt werden kann. Dank stattfindender Hitzekoagulation wird die Blutungsneigung reduziert.

#### Anwendungshinweise:

- Anwendung ohne Kühlung
- Optimale Drehzahl: 300.000 - 450.000 min<sup>-1</sup>

The MEISINGER gingiva trimmers are intended for use in dental mucosal surgery. They have been specially developed for the versatile and gentle treatment of gingival tissue. The working part consists of particularly high-quality and stable zirconia. The main application focus of the MEISINGER gingiva trimmers is the safe and gentle removal of unwanted granulation tissue and hyperplastic gingiva (papillectomy) - even in hard-to-reach areas. Furthermore, the trimmers are used in the enlargement of the sulcus after crown preparation, for the best possible exposition of the preparation margin and the creation of an exact impression. The gingiva trimmers are also particularly suitable for the tissue-saving exposure of covered healed implants and for use in periodontal treatment. The application takes place without cooling, so that the resulting rotational energy can be used for tissue modulation. Thanks to heat coagulation, bleeding tendency is reduced.

#### Instructions for use:

- Application without cooling
- Optimal speed: 300.000 - 450.000 rpm

**GT48L**





Fig.	Schaft / Shank	Ref.-Nr. / Ref.-No.		1
			L mm	5,0
GT48L	FG	700 314 287 484		016



**GT135**

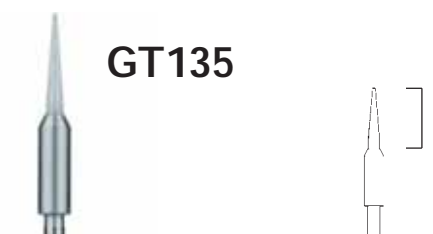



Fig.	Schaft / Shank	Ref.-Nr. / Ref.-No.		1
			L mm	8,0
GT135	FG	700 314 161 484		016





# Hals-, Nasen-, Ohren-Chirurgie

Ear, Nose, Throat Surgery

**242** mittel / medium

Fig.	Schaft / Shank	Ref.-Nr. / Ref.-No.	1	1	1	1	1	1
242	HP XL	806 106 001 524	010	023	030	040	050	060

Kurzer Hals | Short neck

**LH242** mittel / medium

Fig.	Schaft / Shank	Ref.-Nr. / Ref.-No.	1	1	1	1	1	1
LH242	HP XL	806 106 698 524	018	023	031	040	050	060

Langer Hals | Long neck

**236RF** Edelstahl / stainless steel

Fig.	Schaft / Shank	Ref.-Nr. / Ref.-No.	1	1	1	1	1
236RF	HP XL	330 106 001 291	031	035	040	050	060

HNO-Bohrer | E.N.T. burs | Fresas O.R.L.

**HM 236**

Fig.	Schaft / Shank	Ref.-Nr. / Ref.-No.	1
HM 236	HP XL	500 106 001 291	050

HNO-Bohrer | E.N.T. burs

# Innengekühlte Instrumente

Internally cooled instruments

**81IC** Edelstahl / stainless steel

Fig.	Schaft / Shank	Ref.-Nr. / Ref.-No.	1
81IC	RA XL	330 206 007 172	030

# Sonstiges

Miscellaneous

## Mundkeile / Mouth wedges

Mundkeile (S, L, XL)  
Mouth wedges (S, L, XL)



Fig.	MI132 (S)	MI131 (L)	MI130 (XL)
	1	1	1



# Edelstahl-Bohrerstände, rostfrei, sterilisierbar

Stainless Steel Bur Blocks, non-corrosive, sterilizable

MEISINGER Bohrerstände sind ideal geeignet für die effektive Reinigung, Sterilisierung und Sortierung der benötigten Instrumente.

MEISINGER drill stands are ideally suited for the effective cleaning, sterilization and organization of the required instruments.



Art.-No. BS441      B 60 x H 40 x T 45 mm  
Für 8 Winkelstück oder 8 FG-Instrumente  
For 8 RA instruments or 8 FG instruments



Art.-No. BS541      B 120 x H 40 x T 45 mm  
Für 18 Winkelstück oder 18 FG-Instrumente  
For 18 RA instruments or 18 FG instruments



Art.-No. BS440      B 60 x H 40 x T 45 mm  
Für 12 Winkelstück oder 12 FG-Instrumente  
For 12 RA instruments or 12 FG instruments



Art.-No. BS540      B 120 x H 40 x T 45 mm  
Für 24 Winkelstück oder 24 FG-Instrumente  
For 24 RA instruments or 24 FG instruments



Art.-No. BS470      B 60 x H 65 x T 45 mm  
Für 12 Handstück-Instrumente  
For 12 Handpiece instruments



Art.-No. BS570      B 120 x H 65 x T 45 mm  
Für 24 Handstück-Instrumente  
For 24 Handpiece instruments



Art.-No. BS151\*      B 162 x H 51 x T 85 mm  
Für 40 Winkelstück oder 40 FG-Instrumente  
For 40 RA instruments or 40 FG instruments



Art.-No. BS141\*      B 125 x H 40 x T 90 mm  
Für 20 Winkelstück oder 20 FG-Instrumente  
For 20 RA instruments or 20 FG instruments



Art.-No. BS171\*      B 125 x H 70 x T 90 mm  
Für 20 Handstück-Instrumente  
For 20 Handpiece instruments

Für alle | For all



\* Vor der Reinigung muss der Boden entfernt werden. | The base must be removed prior to cleaning.





Art.-No. BS140\*     B 125 x H 40 x T 90 mm  
Für 20 Winkelstück oder 20 FG-Instrumente  
For 20 RA instruments or 20 FG instruments



Art.-No. BS240\*     B 165 x H 40 x T 125 mm  
Für 40 Winkelstück oder 40 FG-Instrumente  
For 40 RA instruments or 40 FG instruments

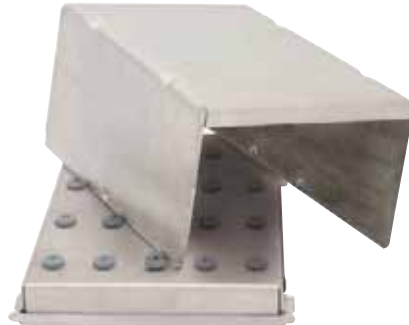

Art.-No. BS170\*     B 125 x H 70 x T 90 mm  
Für 20 Handstück-Instrumente  
For 20 Handpiece instruments

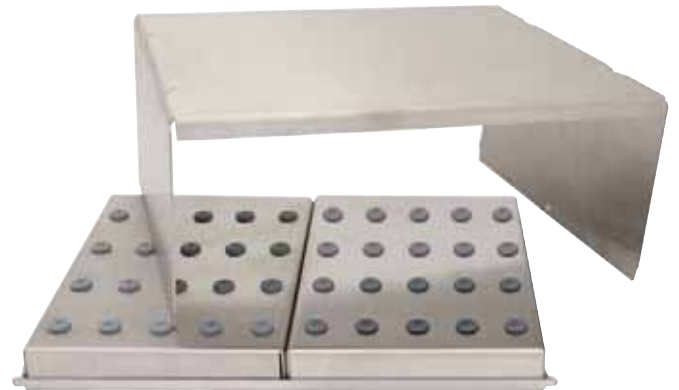

Art.-No. BS270\*     B 165 x H 70 x T 125 mm  
40 Handstück-Instrumente  
40 Handpiece instruments



Art.-No. BS340\*     B 245 x H 40 x T 125 mm  
Für 60 Winkelstück-Instrumente oder 60 FG-Instrumente  
For 60 RA instruments or 60 FG instruments



Art.-No. BS370\*     B 245 x H 70 x T 125 mm  
Für 60 Handstück-Instrumente  
For 60 Handpiece instruments

Für alle | For all



\* Vor der Reinigung muss der Boden entfernt werden. | The base must be removed prior to cleaning.



Art.-No. HI100      B 205 x H 34 x T 143 mm



Art.-No. BWT01      B 205 x H 34 x T 143 mm  
Für 10 Handinstrumente  
For 10 Manual Instruments



Art.-No. BWT02      B 280 x H 34 x T 183 mm  
Für 20 Handinstrumente  
For 20 Manual Instruments

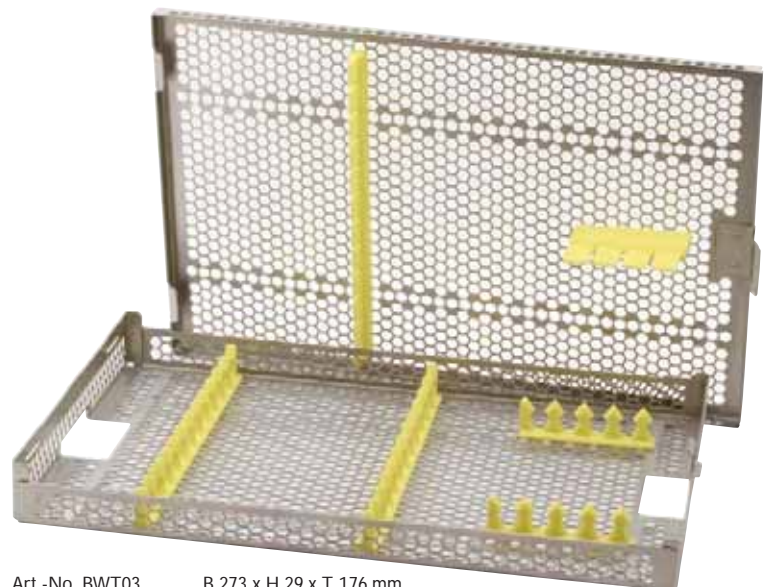

Art.-No. BWT03      B 273 x H 29 x T 176 mm  
Für 16 Handinstrumente  
For 16 Manual Instruments

Für alle | For all





# Drehzahlen

## Rotary Speed

Nachfolgende Drehzahlrichtwerte sind generell in der Chirurgie gültig:

**Handstück (HP):**

Optimal: 6.000 - 10.000 min<sup>-1</sup>  
 Maximal: 40.000 - 50.000 min<sup>-1</sup>

**Winkelstück (RA):**

Optimal: 6.000 - 10.000 min<sup>-1</sup>  
 Maximal: 40.000 - 50.000 min<sup>-1</sup>

**FG:**

Optimal: 80.000 min<sup>-1</sup>  
 Maximal: 100.000 - 120.000 min<sup>-1</sup>

The following reference values for rotation speeds apply to surgery in general:

**Hand piece (HP):**

Optimum: 6.000 - 10.000 rpm  
 Maximum: 40.000 - 50.000 rpm

**Angle piece (RA):**

Optimum: 6.000 - 10.000 rpm  
 Maximum: 40.000 - 50.000 rpm

**Friction Grip (FG):**

Optimum: 80.000 rpm  
 Maximum: 100.000 - 120.000 rpm

Bitte beachten Sie auch die Anpassung der Drehzahlen in Abhängigkeit zum Durchmesser des Instruments sowie die vorliegende Indikation und ausreichende Kühlung. Generell gilt, je größer das Arbeitsteil eines Instrumentes, desto niedriger sollte die Drehzahl eingestellt werden.

Please also observe adapting the rotation speed in relation to the diameter of the instrument as well as the prevailing indication and enough cooling. As a general rule, the larger the working part of an instrument, the lower the speed should be set.

Bitte beachten Sie ebenfalls die gesonderten Aufbereitungsvorgaben bei Produkten aus Werkzeugstahl.

Please also pay attention to the special preparation specifications for products made of tool steel.

Bitte beachten Sie außerdem für die einzelnen Instrumente die empfohlenen und maximalen Drehzahlen auf der Produktverpackung sowie in der entsprechenden Gebrauchsanweisung.

Please also note the recommended and maximum rotary speeds for the individual instruments on the product packaging and in the corresponding instructions for use.

# Anwendungs- und Hygiene-Symbole

## Application and hygiene symbols

Die Symbole geben lediglich Hinweise zu Anwendungsmöglichkeiten der Produkte. Über den konkreten Einsatz entscheidet der Anwender in eigener Verantwortung je nach vorliegender Indikation. Bitte beachten Sie auch die Allgemeinen Anwendungs- und Sicherheitshinweise zu MEISINGER Produkten im medizinischen Bereich und auch die Hinweise zur Aufbereitung. Diese finden Sie im Internet unter [www.meisinger.de](http://www.meisinger.de) sowie auf Anfrage auch gerne auf dem Postweg.

The symbols give merely suggestions for the possible implementation of the products. The user decides and takes full responsibility about the precise deployment according to existing indications. Please follow general application and safety instructions for MEISINGER products in the medical and dental area and also the advice for processing. Details can be found on the internet under [www.meisinger.de](http://www.meisinger.de) or you can request one by mail.

**Zahnheilkunde**

Dentistry

 **Kieferchirurgie**  
 Jaw surgery

 **Implantologie**  
 Implantology

**Reinigung/Desinfektion/Sterilisation**

Cleaning/Disinfection/Sterilization

 **Sterilisierbar im Dampf-Sterilisator (Autoklav) bei der angegebenen Temperatur**  
 Sterilizable in a steam sterilizer (autoclave) at the temperature specified

 **Reinigungs-Desinfektionsgerät für die thermische Desinfektion**  
 Washer-disinfector for thermal disinfection

 **Ultraschallbad**  
 Ultrasonic bath

 **Innendurchmesser**  
 Internal diameter

 **Minimaldurchmesser**  
 Minimal diameter

 **Außendurchmesser**  
 External diameter

 **Drehzahl**  
 Rotary speed

 Bei Wiederverwendung von Einmalprodukten kann ein Infektionsrisiko nicht ausgeschlossen werden und eine risikofreie Funktionssicherheit nicht gewährleistet werden. With the reuse of disposable products the risk of infection cannot be excluded and a risk-free functional safety cannot be guaranteed.

 Bitte beachten Sie auch die Allgemeinen Anwendungs- und Sicherheitshinweise zu MEISINGER Produkten im medizinischen Bereich und auch die Hinweise zur Aufbereitung (Reinigung, Desinfektion und Sterilisation) von Medizinprodukten der Hager & Meisinger GmbH. Bitte beachten Sie die ebenfalls die gesonderten Aufbereitungsvorgaben bei Produkten aus Werkzeugstahl. | Please follow general application and safety instructions for MEISINGER products in the medical area and also the advice for processing (cleaning, disinfection and sterilisation) of medical devices from Hager & Meisinger GmbH. Please also pay attention to the special preparation specifications for products made of tool steel.

Enthält gefährliche Substanzen: Cobalt, CAS: 7440-48-4

Dieses Produkt enthält Cobalt in mehr als 0,1 Masseprozent und ist damit, gemäß aktuellen Regularien, kennzeichnungspflichtig als CMR Stoff Klasse 1B (krebserzeugend, erbgutverändernd und/oder fortpflanzungsgefährdend (en: carcinogenic, mutagenic, reprotoxic)). Es wurde nachgewiesen, dass bei zweckbestimmter Anwendung kein erhöhtes Krebsrisiko oder nachteilige Auswirkungen in Hinblick auf Fortpflanzung oder Erbgutveränderung entstehen.



3723

Contains hazardous substances: Cobalt, CAS: 7440-48-4

This product contains cobalt in more than 0.1 percent by mass and is therefore, in accordance with current regulations, to be labeled as CMR material class 1B (carcinogenic, mutagenic and/or reprotoxic). It has been proven that there is no increased risk of cancer or adverse reproductive or genetic effects when the product is used according to the directions for its intended use.









# Regulatorische Anforderungen

## Regulatory Requirements

Seit 1888 steht Meisinger für qualitativ hochwertige Medizinprodukte. Das Qualitätsmanagementsystem eines Unternehmens, welches Medizinprodukte herstellt, muss besondere Anforderungen erfüllen. Diese besonders hohen Anforderungen sind durch die ISO 13485 definiert und werden von unserem Unternehmen mit großer Sorgfalt erfüllt. Ein MDSAP-Zertifikat nach ISO 13485:2016 bestätigt die Einhaltung der Anforderungen internationaler Behörden von USA (FDA), Kanada (Health Canada), Australien (TGR), Japan (MHLW) und Brasilien (ANVISA). Alle Medizinprodukte, welche Sie als Kunde bei uns erwerben, entsprechen allen anwendbaren Anforderungen der Medizinprodukte-Richtlinie 93/42/EWG. Die Zertifizierung unseres Unternehmens erfolgt durch eine unabhängige Benannte Stelle und wird gemäß Normvorgaben durchgeführt. Aktuelle Zertifikate finden Sie auf unserer Homepage [www.meisinger.de](http://www.meisinger.de).

Meisinger stands for high quality medical devices since 1888. The quality management system of a company which manufactures medical devices must meet specific special requirements. These extremely high requirements are defined in ISO 13485 and meticulously complied with by our company. A MDSAP certificate according to ISO 13485:2016 confirms compliance with the requirements of international authorities in the USA (FDA), Canada (Health Canada), Australia (TGR), Japan (MHLW) and Brazil (ANVISA). All medical devices which you purchase from us as customer, comply with all applicable requirements of the Medical Device Directive 93/42/EEC. Our company is certified by an independent Notified Body and certification is performed according to the specifications of standards. Current certificates can be found on our homepage [www.meisinger.de](http://www.meisinger.de)



### HERSTELLER MANUFACTURER

Hager & Meisinger GmbH  
Hansemannstr. 10  
41468 Neuss | Germany  
Phone: +49 2131 | 2012-0  
Fax: +49 2131 | 2012-222  
E-Mail: [info@meisinger.de](mailto:info@meisinger.de)  
Internet: [www.meisinger.de](http://www.meisinger.de)

## BE001 020,

-021, -010, -090, -015, -017, -018:

### HERSTELLER MANUFACTURER

HELMUT ZEPF Medizintechnik GmbH  
Obere Hauptstr. 16 - 22  
78606 Seitlingen-Oberflacht | Germany  
Internet: [www.zepf-dental.com](http://www.zepf-dental.com)

## Membranes, Sutures, Pro-Fix™

### HERSTELLER MANUFACTURER

Osteogenics Biomedical, Inc.  
4620 71<sup>st</sup> Street | Building 78-79  
Lubbock, TX 79424 | USA  
Phone: 1.888.796.1923  
Fax: 806.796.0059  
E-Mail: [sales@osteogenics.com](mailto:sales@osteogenics.com)  
Internet: [www.osteogenics.com](http://www.osteogenics.com)

Cytoplast™ und Pro-Fix™ sind eingetragene Warenzeichen der Osteogenics Biomedical, Inc..  
Cytoplast™ and Pro-Fix™ are registered trademarks of Osteogenics Biomedical, Inc..

Alle Rechte vorbehalten.

Nachdruck, auch auszugsweise, und reprografische Vervielfältigungen sind nur mit schriftlicher Genehmigung der Hager & Meisinger GmbH, Neuss, zulässig.

Für sämtliche Angebote, Verkäufe und Lieferungen gelten ausschließlich unsere „Allgemeinen Verkaufs- und Lieferbedingungen“.

Programm- und Konstruktionsänderungen sowie Abweichungen der tatsächlichen Ausführungen von den Abbildungen und Angaben bleiben vorbehalten.



eingetragene Warenzeichen

## NanoBone®

### HERSTELLER MANUFACTURER

ARTOSS GmbH  
Friedrich-Barnewitz-Straße 3  
18119 Rostock | Germany  
Phone: +49 (0) 381 | 54345-701  
Fax: +49 (0) 381 | 54345-702  
E-Mail: [info@nanobone.de](mailto:info@nanobone.de)  
Internet: [www.nanobone.de](http://www.nanobone.de)

NanoBone® ist ein eingetragenes Warenzeichen der ARTOSS GmbH. NanoBone® is a registered trademark of ARTOSS GmbH.

All rights reserved.

Reproduction, also by extract and reproducing photos, are only permitted with written authorization of Hager & Meisinger GmbH, Neuss.

All offers, orders, and deliveries are subject to Meisinger's "General Sales and Delivery Terms." We reserve the right to modify our range of products and their design as well as to deviate from the illustrations and data shown.



registered trademarks



Hager & Meisinger GmbH | Hansemannstr. 10 | 41468 Neuss | Germany  
Phone: +49 2131 2012-0 | Fax: +49 2131 2012-222 | E-Mail: [info@meisinger.de](mailto:info@meisinger.de) | Internet: [www.meisinger.de](http://www.meisinger.de)

Meisinger USA. L.L.C. | 10150 E. Easter Avenue | Centennial, Colorado 80112 | USA  
Phone: +1 (303) 268-5400 | Toll free: +1 (866) 634-7464 | Fax: +1 (303) 268-5407 | E-Mail: [info@meisingerusa.com](mailto:info@meisingerusa.com) | Internet: [www.meisingerusa.com](http://www.meisingerusa.com)

