

Meisinger
since
1888



COMPTOIR DENTAIRE
DE BRUXELLES



SUPERDEAL

10 + 2*

20 + 5*

*Les fraises les moins chères à
1,00 euro par pièce

Promotion valable
jusqu'au 31-12-2024

**Instruments diamantés
Instruments en carbure
tungstène**



**Instruments de polissage
Systems & Procedure Packs**

2024

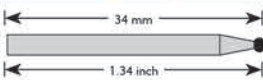
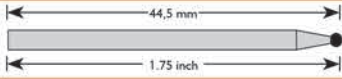

Fraises Meisinger : profitez de remise ONLINE sur nos prix !

TYPES OF SHANKS AND OVERALL LENGTHS

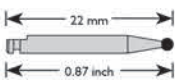
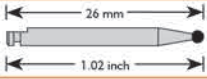

HANDPIECE (HP)**

103		ø 2,35 mm HP S
104		ø 2,35 mm HP
105		ø 2,35 mm HP L
106		ø 2,35 mm HP XL

RIGHT ANGLE (RA)**

204		ø 2,35 mm RA
205		ø 2,35 mm RA L
206		ø 2,35 mm RA XL
207		ø 2,35 mm RA XXL

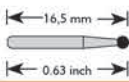
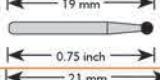
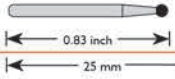
FRICTION GRIP (FG)

313		ø 1,60 mm FG S
314		ø 1,60 mm FG
315		ø 1,60 mm FG L
316		ø 1,60 mm FG XL
317		ø 1,60 mm FG XXL



Souhaitez-vous
une présentation
complète de
la gamme Meisinger
dans votre cabinet ?
Contactez-nous au
03 450 93 20
ou par mail :
marketing@denta.be

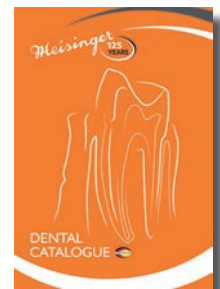

La brochure
**Meisinger
catalogue**
à télécharger via:



Symboles d'utilisation et d'hygiène pour des instruments dentaires

Dentisterie

	Prophylaxie
	Orthodontie
	Chirurgie maxillo-faciale
	Implantologie
	Système de tenons d'obturation radriculaire



Laboratoire

	Technique de précision dentaire
	Technique des stellites
	Elaboration
	Technique de la résine
	Couronnes et ponts
	Technique du revêtement et de la céramique

Traitement dentaire

	Préparation de cavité
	Forage d'obturations anciennes
	Traitement d'obturation
	Préparation de l'épaulement
	Séparation de couronnes
	Traitement radiculaire
	Lissage des racines

Désinfection et stérilisation

	Autoclave avec 134°
	Désinfecteur thermique
	Ultrasonique

Instruments diamantés

A partir de **18,90**



801 V02853
mittel / medium
801H super grob / super coarse
801G grob / coarse
801F fein / fine
801C extra fein / extra fine



Fig.	Schaft / Shank	Ref.-Nr. / Ref.-No.	5	5	5	5	5	5	5	5	5	5	5	5	5	5	2	2	2
801	HP	806 104 001 524				009*	010*	012*	014*	016*	018*	021*	023*		027*		033*		050*
	RA	806 204 001 524					010	012	014	016	018	021	023		027		033		050
	FG s	806 313 001 524					010	012	014										
	FG	806 314 001 524	007	008	009	010	012	014	016	018	021	023	025	027	029		033*	035	042
	FG XL	806 316 001 524				010	012	014	016	018									
801H	HP	806 104 001 544																	050*
	RA	806 204 001 544																	050
	FG	806 314 001 544							014	016	018	021	023	025	027	029			
	FG XL	806 316 001 544							014	016	018		023		029	031			
801G	HP	806 104 001 534					010*		014*	016*	018*		023*				033*		050*
	FG	806 314 001 534				009	010	012	014	016	018	021	023	025	027	029			
	FG XL	806 316 001 534							014	016	018		023						
801F	RA	806 204 001 514								016	018		023				033		
	FG	806 314 001 514				010	012	014	016	018	021	023	025	027	029		033*	035	
801C	HP	806 104 001 504											023*						
	RA	806 204 001 504											023						
	FG	806 314 001 504					012	014	016	018	021	023	025	027	029		033*		



833 V03224
mittel / medium
833H super grob / super coarse
833G grob / coarse
833F fein / fine
833C extra fein / extra fine
833U ultra fein / ultra fine

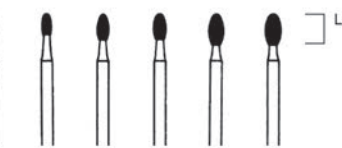

A partir de **18,90**

Fig.	Schaft / Shank	Ref.-Nr. / Ref.-No.	5	5	5	5	5	5
		L mm	2,8	2,8	3,4	3,4	4,2	4,2
833	FG	806 314 277 524		014	016	018		023
833H	FG	806 314 277 544				018		023
833G	FG	806 314 277 534		014	016	018		023
833F	RA	806 204 277 514						023
	FG	806 314 277 514	012	014	016	018	021	023
833C	FG	806 314 277 504		014	016	018		023
833U	FG	806 314 277 494						023



830 V03009
mittel / medium
830H super grob / super coarse
830G grob / coarse
830F fein / fine
830C extra fein / extra fine



A partir de **18,90**

Fig.	Schaft / Shank	Ref.-Nr. / Ref.-No.	5	5	5	5	5
		L mm	4,5	4,5	5,0	5,0	6,0
830	HP	806 104 257 524					023*
	FG	806 314 257 524	016	018	021	023	025
830H	FG	806 314 257 544					023
830G	RA	806 204 257 534					023
	FG	806 314 257 534	016	018		023	025
830F	HP	806 104 257 514					023*
	RA	806 204 257 514					023
	FG	806 314 257 514	016	018	021	023	
830C	RA	806 204 257 504					023 025
	FG	806 314 257 504	016	018	021	023	

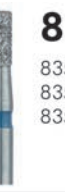

835 V03408
mittel / medium
835H super grob / super coarse
835G grob / coarse
835F fein / fine



A partir de **18,90**

Fig.	Schaft / Shank	Ref.-Nr. / Ref.-No.	5	5	5	5	5	5	5	5
		L mm	3,0	3,0	3,0	3,5	3,5	3,5	3,5	3,5
835	HP	806 104 108 524								035*
	RA	806 204 108 524		008		010	012			
	FG s	806 313 108 524		008	009	010	012			
	FG	806 314 108 524	007	008	009	010	012	014	016	018
835H	FG	806 314 108 544					010	012		
835G	FG	806 314 108 534			009	010	012	014		
835F	FG	806 314 108 514		008	009	010				



801L V03564
mittel / medium
801LG grob / coarse



A partir de **18,90**

Fig.	Schaft / Shank	Ref.-Nr. / Ref.-No.	5	5	5	5	5
801L	HP	806 104 697 524	008	010	012		016
	FG	806 314 697 524		010	012	014	016
801LG	FG	806 314 697 534		010	012	014	016



Instruments diamantés

862 V02655 mittel / medium

A partir de 36,60

862H super grob / super coarse
 862G grob / coarse
 862F fein / fine
 862C extra fein / extra fine
 862U ultra fein / ultra fine

Fig.	Schaft / Shank	Ref.-Nr. / Ref.-No.	L mm	5	5	5	5	5	5
862	HP	806 104 249 524	010*	012*	014*	016*	018*		
	RA	806 204 249 524			014	016			
	FG	806 314 249 524	010	012	014	016		021	
862H	FG	806 314 249 544		012	014	016			
862G	FG s	806 313 249 534		012					
	FG	806 314 249 534	010	012	014	016		021	
862F	HP	806 104 249 514				016*			
	RA	806 204 249 514		012		016			
	FG	806 314 249 514	010	012	014	016			
862C	RA	806 204 249 504		012	014	016			
	FG	806 314 249 504	010	012	014	016			
862U	FG	806 314 249 494		012					

859 V03766 mittel / medium

Prix 36,60

859H super grob / super coarse
 859G grob / coarse
 859F fein / fine
 859C extra fein / extra fine
 859U ultra fein / ultra fine

Fig.	Schaft / Shank	Ref.-Nr. / Ref.-No.	L mm	5	5	5	5	5
859	HP	806 104 166 524	010*		014*		018*	
	RA	806 204 166 524			012			018
	FG	806 314 166 524	010	012	014	016	018	
859H	FG	806 314 166 544						018
859G	FG	806 314 166 534			014	016	018	
859F	HP	806 104 166 514						018*
	RA	806 204 166 514			014			
	FG	806 314 166 514	010	012	014	016	018	
859C	FG	806 314 166 504		012	014	016	018	
859U	FG	806 314 166 494			014			

852 V03192 mittel / medium

A partir de 36,60

852H super grob / super coarse
 852G grob / coarse
 852F fein / fine
 852C extra fein / extra fine

Fig.	Schaft / Shank	Ref.-Nr. / Ref.-No.	L mm	5	5	5	5	5	5
852	HP	806 104 199 524		012*	014*	016*	018*	023*	
	FG	806 314 199 524	010	012	014	016	018	023	
852H	FG s	806 313 199 544					016		
	FG	806 314 199 544		012	014	016	018		
852G	FG	806 314 199 534		012	014	016	018	023	
852F	FG	806 314 199 514		012	014	016	018		
852C	FG	806 314 199 504				016	018		

837L V02646 mittel / medium

A partir de 36,60

837LH super grob / super coarse
 837LG grob / coarse
 837LF fein / fine

Fig.	Schaft / Shank	Ref.-Nr. / Ref.-No.	L mm	5	5	5	5	2	2
837L	HP	806 104 111 524				014*	016*		
	FG	806 314 111 524	010	012	014	016			
837LH	FG	806 314 111 544		012	014	016			
837LG	HP	806 104 111 534						050*	065*
	FG	806 314 111 534		012	014	016			
837LF	FG	806 314 111 514		012	014	016			

837 V03420 mittel / medium

A partir de 36,60

837S ultra grob / ultra coarse
 837H super grob / super coarse
 837G grob / coarse
 837F fein / fine

Fig.	Schaft / Shank	Ref.-Nr. / Ref.-No.	L mm	5	5	5	5	5	5	5	5
837	HP	806 104 110 524	012*	014*	016*	018*	023*		027*		060*
	FG	806 314 110 524	012	014	016	018		025			
837S	HP	806 104 110 554									060*
837H	HP	806 104 110 544							050*	060*	
	FG	806 314 110 544	012	014	016						
837G	FG s	806 313 110 534		014							
	FG	806 314 110 534	012	014	016	018					
837F	HP	806 104 110 514									060*
	FG	806 314 110 514	012	014	016						

858 V03765 mittel / medium

Prix 36,60

858H super grob / super coarse
 858G grob / coarse
 858F fein / fine
 858C extra fein / extra fine

Fig.	Schaft / Shank	Ref.-Nr. / Ref.-No.	L mm	5	5	5
858	HP	806 104 165 524			014*	
	RA	806 204 165 524			014	
	FG s	806 313 165 524			014	
	FG	806 314 165 524	010	014	016	
858H	FG	806 314 165 544		014		
858G	FG	806 314 165 534		014	016	
858F	RA	806 204 165 514		014		
	FG	806 314 165 514	010	014	016	
858C	FG	806 314 165 504	010	014		

Instruments diamantés



850 V03433
mittel / medium

850H super grob / super coarse
850G grob / coarse
850F fein / fine
850C extra fein / extra fine



A partir de **30,72**

Fig.	Schaft / Shank	Ref.-Nr. / Ref.-No.	134°C	5	5	5	5	5	5	2	2
			L mm	8,0	8,0	8,0	8,0	8,0	8,0	8,0	8,0
850	HP	806 104 198 524	012*	016*	018*	023*	025*	033*	040*		
	FG	806 314 198 524	012	014	016	018	021	025			
850H	FG s	806 313 198 544		014	016						
	FG	806 314 198 544	012	014	016	018	021	025			
850G	HP	806 104 198 534				018*	023*				
	FG s	806 313 198 534		014	016						
	FG	806 314 198 534	012	014	016	018	021	023	025		
850F	HP	806 104 198 514						025*			
	FG	806 314 198 514	012	014	016	018	023				
850C	FG	806 314 198 504	012		016						



898 V03819
mittel / medium

898H super grob / super coarse
898F fein / fine
898C extra fein / extra fine
898U ultra fein / ultra fine

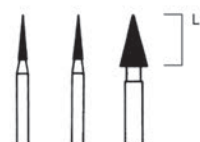

A partir de **30,72**

Fig.	Schaft / Shank	Ref.-Nr. / Ref.-No.	134°C	5	5	2
			L mm	6,0	6,0	7,0
898	HP	806 104 161 524				037*
	RA	806 204 161 524				037
	FG	806 314 164 524	012			
898F	FG	806 314 164 514	012	014		
898C	FG	806 314 164 504		014		
898U	FG	806 314 164 494		014		



841 V03693
mittel / medium

841H super grob / super coarse
841G grob / coarse
841F fein / fine



Prix **36,60**

Fig.	Schaft / Shank	Ref.-Nr. / Ref.-No.	134°C	5	5	5	5	5
			L mm	6,0	6,0	6,0	6,0	6,0
841	FG	806 314 157 524	008	010	012	014	016	
841H	FG	806 314 157 544			012	014		
841G	FG	806 314 157 534			012	014		
841F	FG	806 314 157 514	008	010	012	014		



808L V03608
mittel / medium

808LH super grob / super coarse
808LG grob / coarse
808LF fein / fine



Prix **36,60**

Fig.	Schaft / Shank	Ref.-Nr. / Ref.-No.	134°C	5	5	5	5	5
			L mm	4,0	4,0	5,0	5,0	5,0
808L	FG	806 314 234 524	010	012	014	016	018	
808LH	FG	806 314 234 544			014	016		
808LG	FG	806 314 234 534		012	014	016	018	
808LF	FG	806 314 234 514		012	014			



863 V02945
mittel / medium

863H super grob / super coarse
863G grob / coarse
863F fein / fine
863C extra fein / extra fine



Prix **36,60**

Fig.	Schaft / Shank	Ref.-Nr. / Ref.-No.	134°C	5	5	5	5	5
			L mm	10,0	10,0	10,0	10,0	10,0
863	HP	806 104 250 524	012*	016*	018*	025*		
	RA	806 204 250 524	012		016			
	FG	806 314 250 524	012	014	016	018		
863H	FG	806 314 250 544	012		016	018		
863G	FG	806 314 250 534	012	014	016	018		
863F	RA	806 204 250 514	012					
	FG	806 314 250 514	012	014	016	018		
863C	FG	806 314 250 504	012		016			



808 V03603
mittel / medium

808H super grob / super coarse
808G grob / coarse



Prix **18,90**

Fig.	Schaft / Shank	Ref.-Nr. / Ref.-No.	134°C	5	5	5	5	5
			L mm	2,7	2,7	2,7	3,0	3,0
808	FG	806 314 233 524	009	010	012	014	016	
808H	FG	806 314 233 544				014		
808G	FG	806 314 233 534		010	012	014	016	



807 V03597
mittel / medium

807G grob / coarse



A partir de **18,90**

Fig.	Schaft / Shank	Ref.-Nr. / Ref.-No.	134°C	5	5	5	5	5	5
			L mm	3,5	3,5	4,0	5,0	5,0	6,0
807	HP	806 104 225 524				018*	021*	025*	
	FG	806 314 225 524	012	014	016				
807G	FG	806 314 225 534		014	016	018			



Souhaitez-vous une présentation complète de la gamme Meisinger dans votre cabinet ?

Contactez-nous au **03 450 93 20** ou par mail : marketing@denta.be

Instruments diamantés

840 V03686
mittel / medium
840H super grob / super coarse
840G grob / coarse
840F fein / fine

Prix 18,90

Fig.	Schaft / Shank	Ref.-Nr. / Ref.-No.	5	5	5	5	5
			L mm				
			3,0	4,0	4,0	4,0	4,0
840	FG	806 314 156 524	008	010	012	014	
840H	FG	806 314 156 544		010	012	014	
840G	FG	806 314 156 534	008	010	012	014	016
840F	FG	806 314 156 514	008	010	012	014	

869 V03787
mittel / medium
869H super grob / super coarse
869G grob / coarse
869F fein / fine
869C extra fein / extra fine

Prix 36,60

Fig.	Schaft / Shank	Ref.-Nr. / Ref.-No.	5	5	5	5
			L mm			
			10,0	10,0	10,0	10,0
869	HP	806 104 290 524			014*	
	FG	806 314 290 524	010	012	014	
869H	FG	806 314 290 544			014	
869G	FG	806 314 290 534		012	014	016
869F	FG	806 314 290 514	010	012	014	016
869C	FG	806 314 290 504		012	014	

881 V02663
mittel / medium
881H super grob / super coarse
881G grob / coarse
881F fein / fine
881C extra fein / extra fine

Prix 36,60

Fig.	Schaft / Shank	Ref.-Nr. / Ref.-No.	5	5	5	5	5	5
			L mm					
			8,0	8,0	8,0	8,0	8,0	8,0
881	FG	806 314 141 524	008	010	012	014	016	018
881H	FG	806 314 141 544			012	014		
881G	FG	806 314 141 534			012	014	016	018
881F	FG	806 314 141 514	008	010	012	014	016	018
881C	FG	806 314 141 504			012	014		

838 V03673
mittel / medium
838G grob / coarse
838F fein / fine

A partir de 18,90

Fig.	Schaft / Shank	Ref.-Nr. / Ref.-No.	5	5	5	5	5
			L mm				
			4,0	4,0	4,0	4,0	4,0
838	FG	806 314 138 524	008	009	010	012	014
838G	FG	806 314 138 534				012	014
838F	FG	806 314 138 514			010	012	

842 V02663
mittel / medium
842H super grob / super coarse
842G grob / coarse
842F fein / fine

A partir de 36,60

Fig.	Schaft / Shank	Ref.-Nr. / Ref.-No.	5	5	5	5	5
			L mm				
			8,0	8,0	8,0	8,0	8,0
842	FG	806 314 158 524		012	014	016	018
842H	FG	806 314 158 544		012	014	016	018
842G	FG	806 314 158 534	010	012	014	016	018
842F	FG	806 314 158 514		012	014	016	

868 V03784
mittel / medium
868H super grob / super coarse
868G grob / coarse
868F fein / fine
868C extra fein / extra fine

A partir de 36,60

Fig.	Schaft / Shank	Ref.-Nr. / Ref.-No.	5	5	5	5	5
			L mm				
			8,0	8,0	8,0	8,0	8,0
868	HP	806 104 289 524			012*	014*	
	FG	806 314 289 524		010	012	014	016
868H	FG	806 314 289 544			012	014	016
868G	FG	806 314 289 534	008	010	012	014	016
868F	FG	806 314 289 514	008	010	012	014	016
868C	FG	806 314 289 504			012	014	

836 V02902
mittel / medium
836G grob / coarse

Prix 18,90

Fig.	Schaft / Shank	Ref.-Nr. / Ref.-No.	5	5
			L mm	
			4,0	4,0
836	FG	806 314 109 524	012	014
836G	FG	806 314 109 534		014

831 V03632
mittel / medium
831H super grob / super coarse
831G grob / coarse
831F fein / fine
831C extra fein / extra fine

Prix 18,90

Fig.	Schaft / Shank	Ref.-Nr. / Ref.-No.	5	5
			L mm	
			3,5	3,5
831	FG	806 314 254 524	016	018
831H	FG	806 314 254 544	016	018
831G	FG	806 314 254 534	016	018
831F	FG	806 314 254 514	016	018
831C	FG	806 314 254 504	016	018

890LF V03452
fein / fine
890LC extra fein / extra fine

Prix 18,90

Fig.	Schaft / Shank	Ref.-Nr. / Ref.-No.	5
			L mm
			3,0
890LF	FG	806 314 699 514	008
890LC	FG	806 314 699 504	008

Instruments diamantés

A partir de **36,60**



Fig.	Schaft/Shank	Ref.-Nr./Ref.-No.	L mm	Präparationstiefe (FG) Preparation depth (FG) Profundidad de preparación (FG)						
				5	5	5	5	5	5	5
878	FG	806 314 298 524	8,0	012	014	016	018	021	023	
878H	FG	806 314 298 544	8,0	012	014	016	018	021	023	
878G	FG	806 314 298 534	8,0	010	012	014	016	018	021	023
878F	FG	806 314 298 514	8,0	012	014	016	018	021		



Prix **18,90**



Fig.	Schaft/Shank	Ref.-Nr./Ref.-No.	L mm	Präparationstiefe (FG) Preparation depth (FG) Profundidad de preparación (FG)				
				5	5	5	5	5
806	FG	806 314 019 524	2,5	010	012	014	016	018
806G	FG	806 314 019 534	3,0	012	014	016		



Fig.	Schaft/Shank	Ref.-Nr./Ref.-No.	L mm	Präparationstiefe (FG) Preparation depth (FG) Profundidad de preparación (FG)					
				5	5	5	2	2	2
909	HP	806 104 068 524	0,8	035*					
	RA	806 204 068 524	1,3	035				060	
	FG	806 314 068 524	1,8	031	035	040	050	055	060
909H	FG	806 314 068 544	1,7			040			
909G	FG	806 314 068 534	2,0	031	035	040	050		060
909F	FG	806 314 068 514	2,3			040	050		



A partir de **30,72**

Prix **36,60**



Fig.	Schaft/Shank	Ref.-Nr./Ref.-No.	L mm	Präparationstiefe (FG) Preparation depth (FG) Profundidad de preparación (FG)			
				5	5	5	5
861	HP	806 104 247 524	5,0	012*			016*
	RA	806 204 247 524	5,0	012			
	FG	806 314 247 524	5,0	010	012	014	
861G	FG	806 314 247 534	5,0	010	012	014	
861F	RA	806 204 247 514	5,0		012		
	FG	806 314 247 514	5,0	010	012	014	
861C	FG	806 314 247 504	5,0		012		



Fig.	Schaft/Shank	Ref.-Nr./Ref.-No.	L mm	Präparationstiefe (FG) Preparation depth (FG) Profundidad de preparación (FG)					
				5	5	5	5	5	2
847	HP	806 104 172 524	8,0	014*	016*		023*	033*	040*
	FG	806 314 172 524	8,0	012	014	016	018		
847H	FG s	806 313 172 544	8,0			016			
	FG	806 314 172 544	8,0	014	016	018			
847G	FG	806 314 172 534	8,0	012	014	016	018		
847F	FG	806 314 172 514	9,0	012	014	016			



A partir de **30,72**



Fig.	Schaft/Shank	Ref.-Nr./Ref.-No.	L mm	Präparationstiefe (FG) Preparation depth (FG) Profundidad de preparación (FG)				
				5	5	5	5	5
846	FG	806 314 171 524	6,0	012	014	016	018	025
846H	FG	806 314 171 544	6,0					025
846G	FG	806 314 171 534	6,0			016		025
846F	FG	806 314 171 514	7,0			016		025



A partir de **36,60**



Fig.	Schaft/Shank	Ref.-Nr./Ref.-No.	L mm	Präparationstiefe (FG) Preparation depth (FG) Profundidad de preparación (FG)								
				5	5	5	5	5	5	5	5	5
805	HP	806 104 012 524	0,9	010*	012*	014*	016*	018*	021*	025*	027*	
	FG	806 314 012 524	1,0	009	010	012	014	016	018	021	025	
805H	FG	806 314 012 544	1,5					016				
805G	FG	806 314 012 534	1,5			012	014	016	018			
805F	FG	806 314 012 514	2,3			014						



A partir de **18,90**



Fig.	Schaft/Shank	Ref.-Nr./Ref.-No.	L mm	Präparationstiefe (FG) Preparation depth (FG) Profundidad de preparación (FG)	
				5	5
885	FG	806 314 130 524	8,0	012	014
885H	FG	806 314 130 544	8,0	012	014
885G	FG	806 314 130 534	8,0	012	014
885F	FG	806 314 130 514	8,0	012	014



Prix **36,60**

Instruments diamantés

849 V03191
mittel / medium
849H super grob / super coarse
849G grob / coarse
849F fein / fine

A partir de **36,60**





Fig.	Schaft / Shank	Ref.-Nr. / Ref.-No.	5	5	5	5	5	5
			L mm					
			6,0	6,0	6,0	6,0	6,0	7,0
849	HP	806 104 197 524			014*			025*
	FG	806 314 197 524	010	012	014	016	018	025
849H	FG	806 314 197 544		012	014	016	018	025
849G	HP	806 104 197 534				016*		
	FG s	806 313 197 534						025
	FG	806 314 197 534	010	012	014	016	018	025
849F	FG	806 314 197 514		012	014	016	018	025



838L V02912
mittel / medium
838LG grob / coarse
838LF fein / fine

A partir de **36,60**



Fig.	Schaft / Shank	Ref.-Nr. / Ref.-No.	5	5	5	5	5	5
			L mm					
			7,0	7,0	7,0	7,0	7,0	7,0
838L	HP	806 104 140 524				016*	023*	027*
	FG	806 314 140 524	010	012	014	016		
838LG	FG	806 314 140 534		012	014			
838LF	FG	806 314 140 514		012				



802 V03565
mittel / medium
802G grob / coarse

Prix **18,90**

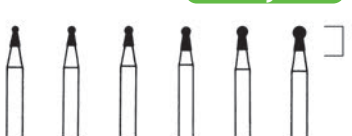



Fig.	Schaft / Shank	Ref.-Nr. / Ref.-No.	5	5	5	5	5	5
			L mm					
			3,0	3,0	3,0	3,5	3,5	3,5
802	FG	806 314 002 524	009	010	012	014	016	018
802G	FG	806 314 002 534		010	012	014	016	



847R V04529
mittel / medium
847RH super grob / super coarse
847RG grob / coarse
847RF fein / fine

A partir de **36,60**





Fig.	Schaft / Shank	Ref.-Nr. / Ref.-No.	5	5	5
			L mm		
			8,0	8,0	8,0
847R	FG	806 314 546 524	016	018	023
847RH	FG	806 314 546 544	016	018	023
847RG	FG	806 314 546 534	016	018	023
847RF	FG	806 314 546 514	016	018	023



A40469
859L mittel / medium

Prix **38,80**



Fig.	Schaft / Shank	Ref.-Nr. / Ref.-No.	5
			L mm
			12,0
859L	RA	806 204 167 524	010



A04175
827C extra fein / extra fine

Prix **36,60**



Fig.	Schaft / Shank	Ref.-Nr. / Ref.-No.	5
			L mm
			4,0
827C	FG	806 314 464 504	018



V31480
883H super grob / super coarse

Prix **36,60**





Fig.	Schaft / Shank	Ref.-Nr. / Ref.-No.	5	5
			L mm	
			7,0	8,0
883H	FG	806 314 146 544	012	016



848 V03189
mittel / medium
848H super grob / super coarse
848G grob / coarse
848F fein / fine
848C extra fein / extra fine

A partir de **30,72**





Fig.	Schaft / Shank	Ref.-Nr. / Ref.-No.	5	5	5	5	5	5	2
			L mm						
			10,0	10,0	10,0	10,0	10,0	10,0	10,0
848	HP	806 104 173 524	012*	014*	016*	018*	021*	023*	031*
	FG	806 314 173 524		014	016	018	021	023	
848H	FG	806 314 173 544		014	016	018			
848G	FG	806 314 173 534		014	016	018	021	023	
848F	FG	806 314 173 514			016	018			
848C	FG	806 314 173 504			016				



820 V03626
mittel / medium
820F fein / fine
820C extra fein / extra fine
820U ultra fein / ultra fine

A partir de **36,60**

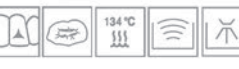

Fig.	Schaft / Shank	Ref.-Nr. / Ref.-No.	5	5	5
			L mm		
			5,0	5,0	4,0
820	FG	806 314 465 524		016	
820F	RA	806 204 465 514		016	
	FG	806 314 465 514		016	031
820C	FG	806 314 465 504	014	016	031
820U	FG	806 314 465 494		016	



Instruments diamantés

A partir de **26,84**



879

V03201
mittel / medium

879S ultra grob / ultra coarse
879H super grob / super coarse
879G grob / coarse
879F fein / fine
879C extra fein / extra fine

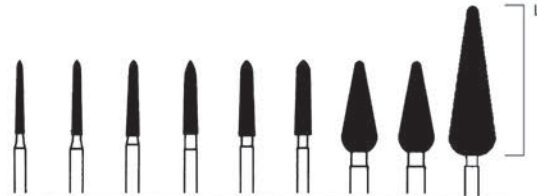
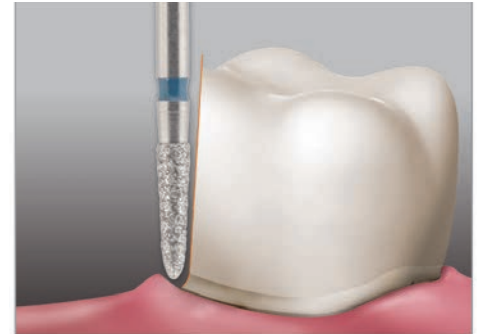

Fig.	Schaft/Shank	Ref.-Nr./Ref.-No.		5	5	5	5	5	5	2	2	1
L mm				10,0	10,0	10,0	10,0	10,0	10,0	12,0	12,0	20,0
879	HP	806 104 266 524								047*		
	FG	806 314 299 524		012	014	016	018	021				
879S	HP	806 104 266 554									050*	
879H	HP	806 104 266 544								047*		060*
	FG	806 314 299 544				016	018	021				
879G	HP	806 104 266 534								047*		
	FG	806 314 299 534		012	014	016	018	021	023			
879F	FG	806 314 299 514		012	014	016						
879C	FG	806 314 299 504				016						



886

V03815
mittel / medium

886H super grob / super coarse
886G grob / coarse
886F fein / fine

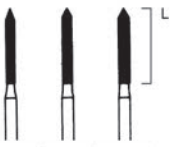

Prix **36,60**

Fig.	Schaft/Shank	Ref.-Nr./Ref.-No.		5	5	5
L mm				10,0	10,0	10,0
886	FG	806 314 131 524		012	014	016
886H	FG	806 314 131 544			014	016
886G	FG	806 314 131 534		012	014	016
886F	FG	806 314 131 514		012	014	016



895

V04949
mittel / medium

895F fein / fine
895C extra fein / extra fine

Prix **18,90**

Fig.	Schaft/Shank	Ref.-Nr./Ref.-No.		5
L mm				3,5
895	FG	806 314 274 524		016
895F	FG	806 314 274 514		016
895C	FG	806 314 274 504		016



872

A03794
mittel / medium

Prix **36,60**

Fig.	Schaft/Shank	Ref.-Nr./Ref.-No.		5
L mm				8,0
872	FG	806 314 223 524		012



867

V03781
mittel / medium

867G grob / coarse
867F fein / fine

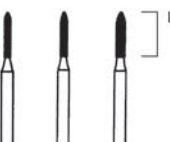

Prix **36,60**

Fig.	Schaft/Shank	Ref.-Nr./Ref.-No.		5	5	5
L mm				6,0	6,0	6,0
867	FG	806 314 288 524		009	010	012
867G	FG	806 314 288 534			010	012
867F	FG	806 314 288 514		009	010	012



889L

V03401
mittel / medium

889LG grob / coarse
889LF fein / fine
889LC extra fein / extra fine

Prix **18,90**

Fig.	Schaft/Shank	Ref.-Nr./Ref.-No.		5	5
L mm				3,5	4,0
889L	FG	806 314 540 524		009	010
889LG	FG	806 314 540 534		009	010
889LF	FG	806 314 540 514		009	010
889LC	FG	806 314 540 504		009	



847KR

A04909
mittel / medium

Prix **56,80**

Fig.	Schaft/Shank	Ref.-Nr./Ref.-No.		5
L mm				8,0
847KR	FG	806 314 585 524		016



802LG

V30923
Endo Access
grob / coarse



Prix **36,60**

Fig.	Schaft/Shank	Ref.-Nr./Ref.-No.		5	5	5
L mm				10,0	10,0	10,0
802LG	FG	806 314 494 534		012	016	019



508

V29204
508G grob / coarse
508F fein / fine

Prix **76,80**

Fig.	Schaft/Shank	Ref.-Nr./Ref.-No.		5	5
L mm				7,5	7,5
508G	FG	806 314 508 534		016	020
508F	FG	806 314 508 514		016	020



833KH

A04790
super grob / super coarse

Prix **36,60**

Fig.	Schaft/Shank	Ref.-Nr./Ref.-No.		5
L mm				3,9
833KH	FG	806 314 272 544		024



Instruments en carbure tungstène

HM 1S V06184

A partir de
24,15

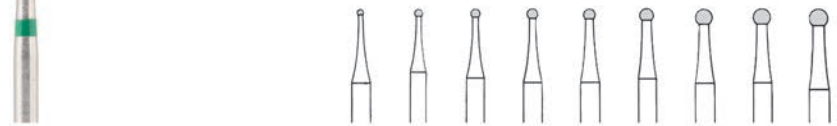

Fig.	Schaft / Shank	Ref.-Nr. / Ref.-No.	5	5	5	5	5	5	5	5	5	5
US-No.			1S	2S	3S	4S	5S	6S	7S	8S	10S	
HM 1S	RA	500 204 001 003	008	010	012	014	016	018	021	023	027	
	RA L	500 205 001 003		010	012	014	016	018	021	023		
	FG	500 314 001 003	008	010	012	014	016	018	021	023		



HM 162 V06235

A partir de
47,32



Fig.	Schaft / Shank	Ref.-Nr. / Ref.-No.	2
			L mm
HM 162	HP	500 104 408 297	018
	RA L	500 205 408 297	018
	RA XL	500 206 408 297	018
	FG XL	500 316 408 297	018



HM 1 V06512

A partir de
23,45

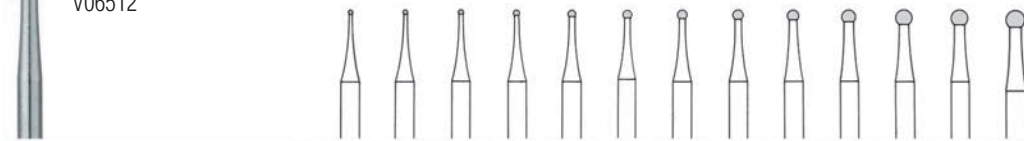
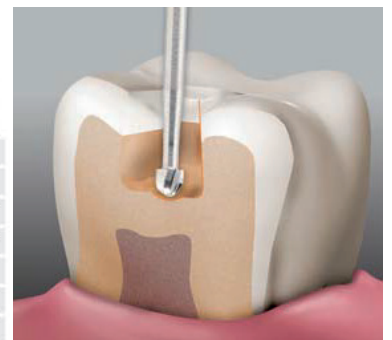

Fig.	Schaft / Shank	Ref.-Nr. / Ref.-No.	5	5	5	5	5	5	5	5	5	5	5	5	
US-No.			1/4	1/2	1	2	3	4	5	6	7	8	10		
HM 1	HP	500 104 001 001	005*	006*	007*	008*	009*	010*	012*	014*	016*	018*	021*	023*	027*
	RA	500 204 001 001	005	006		008	009	010	012	014	016	018	021	023	027
	FG s	500 313 001 001								014					
	FG	500 314 001 001	005	006	007	008		010	012	014	016	018	021	023	
	FG XL	500 316 001 001		006		008		010		014		018		023	



HM 31 V06467

A partir de
23,45

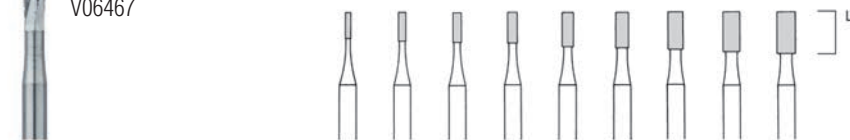

Fig.	Schaft / Shank	Ref.-Nr. / Ref.-No.	5	5	5	5	5	5	5	5		
			L mm	3,6	3,8	4,1	4,1	4,5	4,5	4,9	5,1	5,4
US-No.			555	556	557	558	559	560	561	562	563	
HM 31	HP	500 104 107 007	008*		010*	012*	014*	016*	018*	021*	023*	
	RA	500 204 107 007				012						
	FG s	500 313 107 007			010							
	FG	500 314 107 007		009	010	012	014	016				
	FG XL	500 316 107 007		009	010	012	014					



HM 162 V06235

A partir de
47,32



Fig.	Schaft / Shank	Ref.-Nr. / Ref.-No.	2
			L mm
HM 162	HP	500 104 408 297	018
	RA L	500 205 408 297	018
	RA XL	500 206 408 297	018
	FG XL	500 316 408 297	018



HM 141 V06313

A partir de
29,88

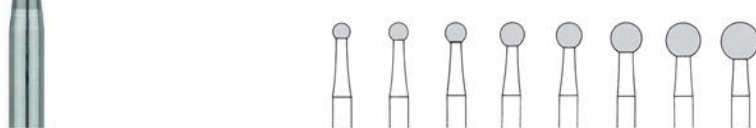

Fig.	Schaft / Shank	Ref.-Nr. / Ref.-No.	2	2	2	2	2	2	2
HM 141	HP	500 104 001 291	023	025	027	031	035	040	050
	RA L	500 205 001 291	023						



HM 1SQ V29033

A partir de
26,10

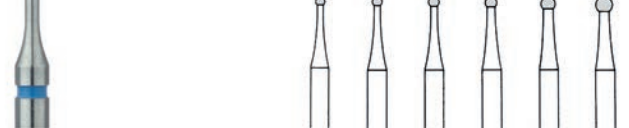

Fig.	Schaft / Shank	Ref.-Nr. / Ref.-No.	5	5	5	5	5	5
HM 1SQ	RA	500 204 001 002	010	012	014	016	018	021
	RA L	500 205 001 002	010	012	014	016	018	021
	FG	500 314 001 002	010	012	014	016	018	021



Instruments en carbure tungstène

HM 71 V05910

A partir de
25,45

Fig.	Schaft / Shank	Ref.-Nr. / Ref.-No.		5	5	5	5	5	5	5	5	5	5	5	2	2	2	2	2
			USA	5	5	5	5	5	5	5	5	5	5	5	1	1	1	1	1
HM 71	HP	500 104 001 175		004	005	006	008	010	012	014	016	018	021	023	025	027	031	040	050

HM 141F V06779

A partir de
18,56

Fig.	Schaft / Shank	Ref.-Nr. / Ref.-No.		2	2	2	2	2	2	2	2	2	2
HM 141F	HP	500 104 001 251		010	014	018	023	027	031	035	040	050	
	RA L	500 205 001 251		010	014	018	023	027	031	035	040	050	
	RA XL	500 206 001 251		010	014	018	023	027	031	035	040	050	

HM D0135 V06839

A partir de
56,80

Fig.	Schaft / Shank	Ref.-Nr. / Ref.-No.		5
			L mm	9,0
			US-No.	ET9
HM D0135	FG	500 314 166 072		014
HM D135F	FG	500 314 166 042		014
HM D135U	FG	500 314 166 032		014

HM 1SQL V30457

Prix
32,65

Fig.	Schaft / Shank	Ref.-Nr. / Ref.-No.		5	5	5	5	5	5
HM 1SQL	RA	500 204 697 002		012	014	016	018	021	023

HM 33L V06585

A partir de
32,00

Fig.	Schaft / Shank	Ref.-Nr. / Ref.-No.		5	5	5	5	5
			L mm	5,3	6,3	6,3	6,3	6,3
			US-No.	699L	700L	701L	702L	703L
HM 33L	HP	500 104 171 007		010*	012*	016*	021*	
	FG L	500 315 171 007		009	010	012		
	FG XL	500 316 171 007		010	012	016		

HM 166RX V06792

Prix
50,08

Fig.	Schaft / Shank	Ref.-Nr. / Ref.-No.		2
			L mm	11,0
HM 166RX	HP	500 104 409 296		021
	RA L	500 205 409 296		021
	RA XL	500 206 409 296		021

HM 21 V06543

Prix
23,45

Fig.	Schaft / Shank	Ref.-Nr. / Ref.-No.		5	5	5	5	5	5	5
			L mm	3,6	3,8	4,1	4,1	4,5	4,5	4,9
			US-No.	56	57	58	59	60	61	
HM 21	HP	500 104 107 006		008*	010*	012*	014*	016*	018*	
	RA	500 204 107 006		008	010	012				
	FG	500 314 107 006		008	009	010	012	014		

Souhaitez-vous une présentation complète
de la gamme Meisinger
dans votre cabinet ?

Contactez-nous au **03 450 93 20**
ou par mail :
marketing@denta.be

Instruments en carbure tungstène

A partir de **23,45**

HM 33

V06580

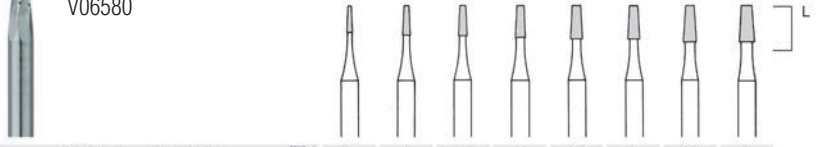
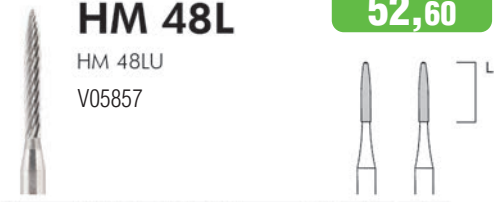

Fig.	Schaft / Shank	Ref.-Nr. / Ref.-No.	☑	5	5	5	5	5	5	5		
				L mm		3,6	3,8	4,1	4,1	4,5	4,9	4,9
				US-No.		698	699	700	701	702	703	703
HM 33	HP	500 104 168 007		008*	009*	010*	012*	014*	016*	018*	021*	
	RA	500 204 168 007					012					
	FG	500 314 168 007			009	010	012		016			
	FG XL	500 316 168 007					012		016		021	



HM 48L

HM 48LU
V05857



A partir de **52,60**

Fig.	Schaft / Shank	Ref.-Nr. / Ref.-No.	☑	5	5		
				L mm		8,0	8,0
HM 48L	FGXXL	500 317 249 072		014	023		
HM 48LU	FGXXL	500 317 249 032		014	023		



HM 161

V06085

Prix **38,72**



Fig.	Schaft / Shank	Ref.-Nr. / Ref.-No.	☑	2	
				L mm	11,0
HM 161	HP	500 104 408 295		018	
	RA L	500 205 408 295		018	
	FG XL	500 316 408 295		018	



HM 379

HM 379U
V05775

A partir de **47,70**

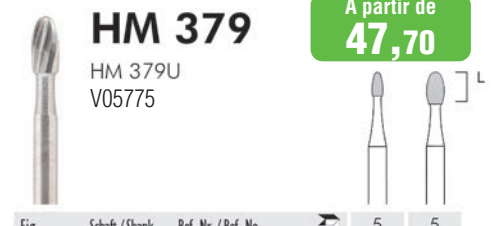

Fig.	Schaft / Shank	Ref.-Nr. / Ref.-No.	☑	5	5		
				L mm		3,1	4,2
				US-No.		7404	7408
HM 379	FGXXL	500 317 277 072		014	023		
HM 379U	FGXXL	500 317 277 032		014	023		



HM 191A

34 mm total length
V40809

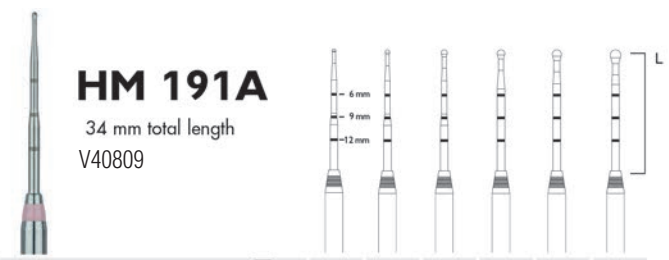

Fig.	Schaft / Shank	Ref.-Nr. / Ref.-No.	☑	2	2	2	2	2	2						
				L mm						16,0	16,0	16,0	16,0	16,0	16,0
				US-No.						1/4	1/2	1	2	3	4
HM 191A	RAXL	500 206 004 006		005											
HM 191A	RAXL	500 206 004 006			006										
HM 191A	RAXL	500 206 004 006				008									
HM 191A	RAXL	500 206 004 006					010								
HM 191A	RAXL	500 206 004 006						012							
HM 191A	RAXL	500 206 004 006							014						
HM 191A	RAXL	500 206 004 006											018		



Prix **16,60**

HM 191A

31 mm total length
V40802



Fig.	Schaft / Shank	Ref.-Nr. / Ref.-No.	☑	2	2	2	2	2	2	2	2							
				L mm								16,0	16,0	16,0	16,0	16,0	16,0	16,0
				US-No.								1/4	1/2	1	2	3	4	6
HM 191A	RAL	500 205 004 006		005														
HM 191A	RAL	500 205 004 006			006													
HM 191A	RAL	500 205 004 006				008												
HM 191A	RAL	500 205 004 006					010											
HM 191A	RAL	500 205 004 006						012										
HM 191A	RAL	500 205 004 006							014									
HM 191A	RAL	500 205 004 006															018	



Prix **15,76**

HM 21R

V06550

Prix **28,10**



Fig.	Schaft / Shank	Ref.-Nr. / Ref.-No.	☑	5	5	5	5	5					
				L mm					3,6	3,8	4,1	4,1	4,9
				US-No.					1155	1156	1157	1158	
HM 21R	RA	500 204 137 006					012	018					
	FG	500 314 137 006		008	009	010	012						



HM 246

HM 246U
V06787

A partir de **47,70**



Fig.	Schaft / Shank	Ref.-Nr. / Ref.-No.	☑	5	5	5	5	5					
				L mm					3,6	3,6	3,6	3,6	3,6
				US-No.					7901	7902	7903	7904	
HM 246	HP	500 104 496 071		008*									
	FG	500 314 496 071		008	009	010	012	014					
HM 246U	FG	500 314 296 031			009								



Instruments en acier



1 RF
V05046
Stahl / steel
Edelstahl / stainless steel

A partir de
11,20

Fig.	Schaft / Shank	Ref.-Nr. / Ref.-No.		10	10	10	10	10	10	10	10	10	10	10	10	10	10	10	10	5	
1	HP	310 104 001 001		004*	005*	006*	007*	008*	009*	010*	012*	014*	016*	018*	021*	023*	025*	027*	029*	031*	033*
	RA	310 204 001 001			005	006	007	008	009	010	012	014	016	018	021	023	025	027	029	031	
	RA L	310 205 001 001							009	010	012	014	016	018	021	023					
	RA XL	310 206 001 001								010	012	014	016	018		023					
1RF*	HP	330 104 001 001			005*		007*		009*	010*		014*	016*		023*						

Fig.	Schaft / Shank	Ref.-Nr. / Ref.-No.		5	5	5	5						
1	HP	310 104 001 001		035*	037*	040*	050*						

166
166RF
V05226
Stahl / steel
Edelstahl / stainless steel

A partir de
31,00

Fig.	Schaft / Shank	Ref.-Nr. / Ref.-No.		2
			L mm	10,0
166	RA L	310 205 409 297		021
166RF	HP	330 104 409 297		021

162
162RF
V05222
Stahl / steel
Edelstahl / stainless steel

A partir de
30,20

Fig.	Schaft / Shank	Ref.-Nr. / Ref.-No.		2
			L mm	9,0
162	RA L	310 205 408 297		016
	FG XL	310 316 408 297		016
162RF	HP	330 104 408 297		016
	RA L	330 205 408 297		016
	FG XL	330 316 408 297		016

168
168RF
V05234
Stahl / steel
Edelstahl / stainless steel

A partir de
34,32

Fig.	Schaft / Shank	Ref.-Nr. / Ref.-No.		1
			L mm	22,0
168	HP L	310 105 411 297		023
168RF	HP L	330 105 411 297		023

191R
V16626
Stahl / steel

Prix
43,00

Fig.	Schaft / Shank	Ref.-Nr. / Ref.-No.		10	10	10	10	10
			L mm	18,0	18,0	18,0	18,0	18,0
191R	RA XL	330 206 698 001		100	120	140	160	180

75
V05684
Stahl / steel

A partir de
25,60

Fig.	Schaft / Shank	Ref.-Nr. / Ref.-No.		5	5	5	5	5
			L mm	8,0	9,5	11,0	12,5	14,0
75	HP	310 104 260 171		040	050	060	070	080

229L
V43629
Edelstahl / stainless steel

A partir de
85,16

Fig.	Schaft / Shank	Ref.-Nr. / Ref.-No.		1	1	1	1	1	1	1	1	1	1	1	1
			L mm	14,0	14,0	14,0	14,0	14,0	14,0	14,0	14,0	14,0	14,0	14,0	14,0
			L mm	4,00	4,50	5,00	5,50	6,00	6,50	7,00	7,50	8,00	8,50	9,00	
				3,00	3,50	4,00	4,50	5,00	5,50	6,00	6,50	7,00	7,50	8,00	
229L	RA L	330 205 555 001		030	035	040	045	050	055	060	065	070	075	080	

Instruments de polissage

White "Arkansas" abrasives, extra fine, for smooth grinding and polishing of filling materials and composites. Significant reduction of the edge gap.

645XF V20231
extra fein / extra fine

Prix
15,90

Fig.	Schaft / Shank	Ref.-Nr. / Ref.-No.		5
			L mm	7,0
645XF	HP	635 104 161 505		028*
	RA	635 204 161 505		028
	FG	635 314 161 505		028



601XF V20219
extra fein / extra fine

Prix
15,90

Fig.	Schaft / Shank	Ref.-Nr. / Ref.-No.		5
			L mm	7,0
601XF	HP	635 104 001 505		030*
	RA	635 204 001 505		030
	FG	635 314 001 505		030



661XF V04220
extra fein / extra fine

Prix
15,90

Fig.	Schaft / Shank	Ref.-Nr. / Ref.-No.		5
			L mm	7,0
661XF	HP	635 104 288 505		025*
	RA	635 204 288 505		025
	FG	635 314 288 505		025



660XF V39367
extra fein / extra fine

Prix
15,90

Fig.	Schaft / Shank	Ref.-Nr. / Ref.-No.		5
			L mm	7,0
660XF	RA	635 204 297 505		025
	FG	635 314 297 505		025



9501U V20370

Prix
11,00

Fig.	Schaft / Shank	Ref.-Nr. / Ref.-No.		5
			L mm	15,0
9501U	HP	658 104 257 523		055*
	RA	658 204 257 523		055



662 V20268
mittel / medium

Prix
12,50

Fig.	Schaft / Shank	Ref.-Nr. / Ref.-No.		5
			L mm	7,5
662	HP	655 104 288 523		035*
	RA	655 204 288 523		035



9769M V28066
9769F

Fig.	Schaft / Shank	Ref.-Nr. / Ref.-No.		2	2
			L mm	1,6	1,6
9769M	RA	803 204 000 523		100	
9769M	RA	803 204 000 523		140	
9769M	HP	803 104 000 523		140*	
9769M	HP	803 104 000 523		170*	
9769F	RA	803 204 000 503			100
9769F	RA	803 204 000 503			140
9769F	HP	803 104 000 503			140*
9769F	HP	803 104 000 503			170*



A partir de
26,28

Occlu Twist Polishers

This two-step polishing system produces high gloss results on all composite materials. Even hybrid composites, micro-filled composites and high-density restorative materials can be easily processed with the Occlu Twist polishers. Occlu Twist polishers are applicable without polishing paste and achieve brilliant polishing results in a very short processing time.

9765M V46892
9765F

Fig.	Schaft / Shank	Ref.-Nr. / Ref.-No.		2	2
			L mm	5,5	5,5
9765M	RA	803 204 000 523		055	
9765F	RA	803 204 000 503			055



Prix
20,68

Brossette fraises laiton Omnident

A41409 par pièce



Prix: 2,20

Par 2 / pièce
1,95

Trihawk FG

A28542 fraises carbure tungstène 20 pièces

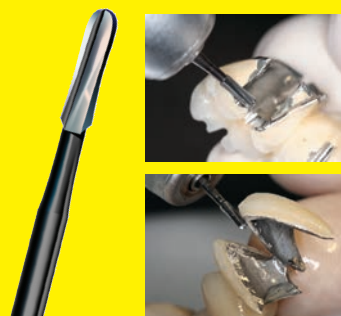

Prix: 69,50

Par 5 / pièce
59,50

9573V V20307
9573P
9573H

Fig.	Schaft / Shank	Ref.-Nr. / Ref.-No.		5	5	5
			L mm	24,0	24,0	24,0
9573V	HP	658 104 273 536		100		
9573P	HP	658 104 273 534			100	
9573H	HP	658 104 273 524				100



Prix
16,60

Instruments de polissage

9504U V36139

Prix
11,00



Fig.	Schaft / Shank	Ref.-Nr. / Ref.-No.		5	5	
				L mm	10,0	8,5
9504U	RA	658 204 030 523		070	090	



661 V20276
mittel / medium

Prix
12,50



Fig.	Schaft / Shank	Ref.-Nr. / Ref.-No.		5	
				L mm	7,0
661	HP	655 104 288 523		025*	
	RA	655 204 288 523		025	



645F V20235
fein / fine

Prix
15,90



Fig.	Schaft / Shank	Ref.-Nr. / Ref.-No.		5	
				L mm	7,0
645F	HP	655 104 161 513		028*	
	RA	655 204 161 513		028	
	FG	655 314 161 513		028	



9762M V36374
9762F



Fig.	Schaft / Shank	Ref.-Nr. / Ref.-No.		2	2	
				L mm	10,0	10,0
9762M	RA	803 204 243 526		040		
9762F	RA	803 204 243 506			040	



Prix
24,22

601 V20223
mittel / medium

Prix
12,50



Fig.	Schaft / Shank	Ref.-Nr. / Ref.-No.		5
601	HP	655 104 001 523		030*
	RA	655 204 001 523		030



601F V20248
fein / fine

Prix
15,90



Fig.	Schaft / Shank	Ref.-Nr. / Ref.-No.		5
601F	RA	655 204 001 513		030
	FG	655 314 001 513		030



9526V V33296
9526P



Fig.	Schaft / Shank	Ref.-Nr. / Ref.-No.		5	5	
				L mm	10,5	10,5
9526V	RA	658 204 300 522		047		
9526P	RA	658 204 300 512			047	



Prix
16,60

661F V20225
fein / fine

Prix
15,90



Fig.	Schaft / Shank	Ref.-Nr. / Ref.-No.		5	
				L mm	7,0
661F	HP	655 104 288 513		025*	
	RA	655 204 288 513		025	
	FG	655 314 288 513		025	



662XF V39368
extra fein / extra fine

Prix
15,90



Fig.	Schaft / Shank	Ref.-Nr. / Ref.-No.		5	
				L mm	7,0
662XF	RA	635 204 297 505		030	
	RAAs	635 203 297 505		030	



Disques diamantés

916D mittel / medium V31297



A partir de
26,84

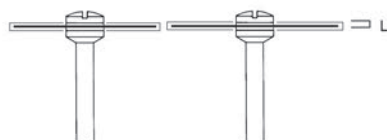

Fig.	Schaft / Shank	Ref.-Nr. / Ref.-No.		1	1	
				L mm	0,5	0,5
916D	HP	806 104 327 524		190	220	
	unmounted	806 900 327 524		190	220	



915DM mittel / medium V49563



A partir de
28,24

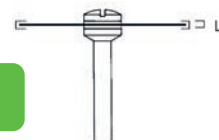

Fig.	Schaft / Shank	Ref.-Nr. / Ref.-No.		1	
				L mm	0,25
915DM	HP	806 104 35M 524		220	
	unmounted	806 900 35M 524		220	



231DC extra fein / extra fine V39956

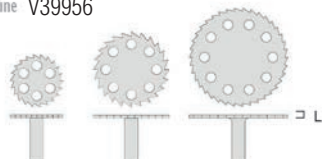

Fig.	Schaft / Shank	Ref.-Nr. / Ref.-No.		1	1	1	
				L mm	0,3	0,3	0,3
231DC	HP	806 104 064 504		070	100		
	RA	806 204 064 504		070*	100*	130*	



A partir de
58,68



918D mittel / medium V36310

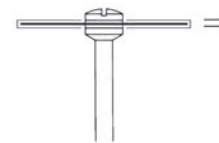

Fig.	Schaft / Shank	Ref.-Nr. / Ref.-No.		1	
				L mm	0,5
918D	HP	806 104 335 524		220	
	unmounted	806 900 335 524		220	



A partir de
26,84

2565 Occlusal Reduction Kit

A40305 developed with Dr. Athas N. Kometas DMD, PA, Daytona Beach



Prix: 143,06

Promo
119,00

The Patented Occlusal Reduction Burs (United States Patent number 6,511,322) allow for precise occlusal reductions to be achieved. The vertical orientation provides great access to the occlusal plane. The Occlusal Reduction Burs are available in 1.5 mm, 1.8 mm, 2.0 mm, 2.2 mm, and 2.4 mm depths corresponding to proper occlusal reduction for various restorative materials. A 1.0 mm bur is also available for labial reduction. Developed by Athas N. Kometas, DMD.

L'Occlusal Reduction Kit (brevet États-Unis numéro 6,511,322) permet de procéder à des réductions occlusales précises. L'orientation verticale assure un bon accès à la face occlusale. Les forets sont disponibles dans des profondeurs de 1,5 mm, 1,8 mm, 2,0 mm, 2,2 mm et 2,4 mm, selon les matériaux de restauration choisis. Un foret pour la réduction labiale, d'une profondeur de 1,0 mm, est également présent dans le kit. Développé par Athas N. Kometas, DMD.

OCCLUSAL REDUCTION |

Depth	Indications
□ 1,0 mm	Maxillary anterior lingual and axial, Monolithic opaque Zirconia
■ 1,5 mm	Monolithic opaque Zirconia
■ 1,8 mm	Monolithic translucent Zirconia
■ 2,0 mm	e.max; Layered porcelain, Monolithic porcelain, Incisal reduction
■ 2,2 mm	Layered Porcelain, 0.7 mm Core + 1.5 mm Veneer
■ 2,4 mm	Layered porcelain, Incisal reduction

	Fig.	Shank ¹	Length	Size	Pieces/Kit
	828G	FG	L=1.5 mm	017	1
	828O	FG	L=1.8 mm	017	1
	828Y *	FG	L=2.0 mm	017	1
	828B	FG	L=2.2 mm	017	1
	828R	FG	L=2.4 mm	017	1
	828W	FG L	L=1.0 mm	017	1

¹ 314=FG, 315=FG L

* 828Y is ideal for precisely achieving the occlusal minimum thickness for CAD/CAM restorations

SC02 CAD/CAM Prep Kit

A45930



Prix: 246,06

Promo
205,00

The CAD/CAM Prep Kit contains an ideal selection of award-winning diamonds including all the necessary shapes for inlays, onlays and full coverage crowns. Included in the kit are MEISINGER'S 1.5 mm and 2 mm depth limiting Occlusal Reduction Burs for predictable occlusal reductions.

Le CAD/CAM Prep Kit contient une sélection idéale de diamants, récompensés par des prix, y compris toutes les formes nécessaires pour les préparations d'inlays, d'onlays et de couronnes. Ce kit contient les fraises Occlusal Reduction Burs de MEISINGER, d'une profondeur de 1,5 mm et 2 mm, pour un enlèvement de substance occlusale planifiable.

	Fig.	Shank ¹	Ref.-No.	Size	Pieces/Kit
	856F	FG	806 314 194 514	016	1
	856F	FG	806 314 194 514	018	1
	856F	FG	806 314 194 514	021	1
	856H	FG	806 314 194 544	016	1
	856H	FG	806 314 194 544	018	1
	801F	FG	806 314 001 514	018	1
	801F	FG	806 314 001 514	023	1
	845RH	FG	806 314 544 544	018	1
	845RH	FG	806 314 544 544	025	1
	845RF	FG	806 314 544 514	018	1
	828Y	FG	L=2.0mm	017	1
	833	FG	806 314 277 524	023	1
	833F	FG	806 314 277 514	023	1
	828G	FG	L=1.5mm	017	1
	850F	FG	806 314 198 514	012	1
	850H	FG	806 314 198 544	012	1
	850H	FG	806 314 198 514	021	1

¹ 314=FG, 315=FG L

2561 Athen Preparation Crown & Inlay Kit

A42456 according to Stavros Pelekanos, DDS

Prix: 193,06

Promo
160,50



The Athens Preparation & Crown Inlay Kit provides an intelligent compilation of instruments for optimal crown and inlay preparation. The torpedo-like diamond instruments equipped with an axially extending locator pin are suited for the creation of a defined chamfer. The circular chamfer is easily prepared supragingivally, while the polished locator pin is guided around the tooth without pressure.

Le Athen Preparation Crown & Inlay Kit est un ensemble intelligent d'instruments pour la préparation optimale de couronnes et d'inlays. Les instruments diamantés en forme de torpilles, avec tige de guidage à évolution axiale, conviennent pour la création d'un congé (chanfrein) défini. Le congé se crée circulairement, de façon légèrement supra-gingivale, en passant la tige de guidage polie autour de la dent, sans pression.

2522 Preparation Set

A33297 according to Prof. Dr. Karl-Peter Meschke

Prix: 129,44

Promo
107,50



An easy and user friendly preparation set for defined material removal for crowns and inlay preparation.

Kit de préparation facile à manipuler, pour l'enlèvement défini de matière dans le domaine de la préparation de couronnes et d'inlays.

	Fig.	Shank ¹	Ref.-No.	Size	Pieces/Kit
	859	FG	806 314 166 524	010	1
	881G	FG	806 314 141 534	014	1
	869G	FG	806 314 290 534	012	1
	869G	FG	806 314 290 534	014	1
	833G	FG	806 314 277 534	023	1
	881F	FG	806 314 141 514	014	1
	869F	FG	806 314 290 514	012	1
	869F	FG	806 314 290 514	014	1
	833F	FG	806 314 277 514	023	1
	509F	FG	806 314 189 514	016	1
	811LG	FG	806 314 039 534	037	1
	847RG	FG	806 314 546 534	018	1
	847RF	FG	806 314 546 514	018	1
	847RF	FG	806 314 546 514	016	1

¹ 314=FG

	Fig.	Shank ¹	Ref.-No.	Size	Pieces/Kit
	809	FG	806 314 232 524	008	1
	838G	FG	806 314 138 534	012	1
	838F	FG	806 314 138 514	012	1
	838L	FG	806 314 140 524	012	1
	838LF	FG	806 314 140 514	012	1
	849G	FG	806 314 197 534	025	1
	855G	FG	806 314 196 534	016	1
	866	FG	806 314 287 524	009	1
	867F	FG	806 314 288 514	009	1
	868G	FG	806 314 289 534	012	1
	868G	FG	806 314 289 534	014	1
	868G	FG	806 314 289 534	016	1
	868F	FG	806 314 289 514	012	1
	868F	FG	806 314 289 514	014	1
	868F	FG	806 314 289 514	016	1
	899	FG	806 314 033 524	027	1
	HM 21RX	FG	500 314 137 019	010	1

¹ 314=FG

2413 Laminate Veneer Kit

A28797

Prix: 117,52

Promo
97,90



The two depth cutters 834-016 and 834-021 assist with creating pre defined depths on facial surfaces. The smaller creates a 0.3 mm depth on the central incisors and canines, while the larger head size creates a 0.5 mm depth on lateral incisors. The 852 series reduces the facial tooth structure to the pre determined depth. the 852 shaped diamond may also be used on the lingual wrap. the 820 shaped diamond removes interproximal flash and overhang. the 889L and 898 diamonds create an infinite margin and may assist subgingivally.

Ce kit contient un assortiment adapté de façon optimale, pour l'application de facettes dans la région des dents antérieures. Les marqueurs de profondeur 834 aident à cet égard à créer une profondeur de préparation définie (0,3 et 0,5 mm) sur la face labiale des dents. Les instruments diamantés 852 servent en particulier à enlever rapidement la substance dure de la dent (région labiale), jusqu'à la profondeur prédéterminée, l'instrument pouvant également être utilisé dans les régions palatinales / linguales. Les diamants 820 éliminent de façon fiable l'excès de substance dans la zone interdentaire, tandis que les diamants 889L et 898C permettent une finition efficace du bord, mais ils peuvent par également être utilisés en sous-gingival.

	Fig.	Shank ¹	Ref.-No.	Size	Pieces/Kit
	820C	FG	806 314 465 514	016	1
	833C	FG	806 314 277 504	023	1
	834^A	FG	806 314 552 524	016	1
	834^B	FG	806 314 552 524	021	1
	852	FG	806 314 199 524	016	1
	852	FG	806 314 199 524	018	1
	852G	FG	806 314 199 534	016	1
	852G	FG	806 314 199 534	018	1
	889LF	FG	806 314 540 514	009	1
	898C	FG	806 314 540 504	014	1

¹ 314=FG

^A Cutting depth 0.3 mm

^B Cutting depth 0.5 mm

LUS06 LUSTER® Intraoral Twist Kit

A45932

THE DENTAL
ADVISOR

Prix: 108,14

Promo
90,00



The Luster® Intraoral Twist Kit has been especially developed for intraoral high-gloss polishing of all ceramic restorations. the flexible polishing discs make it possible to adapt to any surface structure and also render flawless results in areas that are difficult to reach, such as occlusal surfaces. Due to designs that are gentle on materials, the original surface structure of the restoration is maintained. In addition, the grades of diamond grit separated into four parts provide for short processing times and extremely high levels of durability.

Le kit LUSTER® Intraoral Twist Kit a été spécialement développé pour le brillantage intrabuccal de toutes les restaurations en céramique. Les lamelles de polissage flexibles permettent une adaptation à chaque structure de surface et génèrent, même dans les zones difficiles d'accès comme, par exemple, la face occlusale, des résultats impeccables. Grâce à la conception qui ménage le matériau, la structure de surface d'origine de la restauration est conservée. L'échelonnement en quatre parties du grain de diamant assure par ailleurs des temps de traitement courts et des durées de vie extrêmement longues.



	Fig.	Shank ¹	Ref.-No.	Size	Pieces/Kit
	9771G	RA	803 204 000 534	140	1
	9771M	RA	803 204 000 524	140	1
	9771F	RA	803 204 000 514	140	1
	9771C	RA	803 204 000 504	140	1

¹ 204=RA

GC02 Intraoral Twist Polisher Kit for Silicate Ceramics

A41144 according to Greg Campbell, DDS

Prix: 139,46

Promo
115,90



Developed in collaboration with Greg Campbell, DDS, the Meisinger twist Polisher Kit for silicate Ceramics is designed to be simple and efficient. This kit provides the proper diamonds and polishers for adjusting and polishing silicate Ceramics. The diamonds will gently adjust the occlusal surfaces and the margins in preparation for polishing. Two Polishing points and Meisinger's twist polishers are included for blending and polishing the margins, cusps, and occlusal surfaces.

Les kits Twist Polisher Kits for Silicate Ceramics de MEISINGER contiennent les instruments recommandés par Greg Campbell, DDS, pour l'usinage facile et efficace de céramiques au silicate. Le kit pour le cabinet dentaire offre les instruments parfaits pour un traitement et un polissage intrabuccaux de la surface en silicate. Les instruments diamantés permettent une adaptation en douceur des faces occlusales et des bords des couronnes. À l'aide des polissoirs de grande qualité, on procède enfin à un brillantage final.

LUS91 LUSTER® for Zirconia

A41070 Intraoral Adjusting Kit

Prix: 128,18

Promo
106,50



The MEISINGER LUSTER® for Zirconia has been specially developed for use on layered and monolithic Zirconium Oxide restorations. The hardness of Zirconia materials ranges from 850 MPa to 1200 MPa. One of the keys to adjusting and polishing these materials is to perform the tasks quickly and without creating excessive heat. MEISINGER has formulated these zirconia polishers to minimize heat buildup and thus minimize the possibilities of micro-fractures without excessive wear and tear of the polishing materials. The kit contains two-step polishers that can be used without polishing paste. Further instruments for adjusting and contouring are included.

Le système de polissage LUSTER® for Zirconia de MEISINGER a été spécifiquement développé pour être utilisé sur des restaurations en oxyde de zirconium stratifiées et monolithiques. Ce système comprend des polissoirs diamantés pour application intrabuccale. La dureté des zircons va de 850 MPa à 1 200 MPa. Une clé, pour le traitement de l'oxyde de zirconium, constitue une méthode rapide avec dégagement de chaleur minimum. MEISINGER a développé le kit LUSTER® spécifiquement pour le polissage intrabuccal de l'oxyde de zirconium. Ceci permet de minimiser le dégagement de chaleur et d'éviter les microfissures. Le kit contient des polissoirs de pré-polissage et des polissoirs de brillantage, qui peuvent être utilisés sans pâte à polir. D'autres instruments, pour le polissage de points de contact, viennent compléter le système. Le système de polissage en deux étapes séduit par sa facilité de manipulation et par l'obtention de résultats très brillants.

	Fig.	Shank ¹	Ref.-No.	Size	Pieces/Kit
	805F	FG	806 314 012 514	014	1
	862F	FG	803 314 249 514	010	1
	830F	FG	806 314 257 514	021	1
	DPO02	RA	803 204 244 522	040	1
	9771M	RA	803 204 000 524	140	1
	DPO05	RA	803 204 244 512	040	1
	9771C	RA	803 204 000 504	140	1

¹ 314=FG, 204=RA

	Fig.	Shank ¹	Ref.-No.	Size	Pieces/Kit
	Z0801	FG	806 314 001 324	010	1
	Z0850	FG	806 314 198 324	018	1
	Z0833	FG	806 314 277 324	023	1
	DCA04	RA	803 204 244 524	040	1
	DCA13	RA	803 204 030 525	060	1
	DCA10	RA	803 204 244 514	040	1
	DCA14	RA	803 204 030 514	060	1

¹ 204=RA, 314=FG



OMNIDRILL désinfection instrument Omnident

A36188 **2 litres** Prix: 13,50

Promo
12,90

A36189 **10 litres** Prix: 51,90

Promo
49,90

5901 Zirkon Diamond Kit

A39944

Prix: 187,38

Promo
157,00



The instruments of the Zirkon Diamond Kit have been specifically developed for working on Zirconium Dioxide surfaces. Various grain sizes and a number of different shapes offer flexible and efficient use for different indications. The diamond grains are well adapted to adjust Zirconium Oxide Ceramics.

Les instruments du kit Zirkon Diamond ont été spécifiquement développés pour répondre aux exigences du traitement de surfaces en dioxyde de zirconium sensibles. Différentes grosseurs de grains et une multitude de formes différentes permettent une utilisation flexible et efficace pour différentes indications. Les grains de diamant sont à cet égard adaptés à l'oxyde de zirconium de telle sorte que l'enlèvement de la surface de matière sensible s'effectue de façon optimale.

JK04 Zirconia Finishing Kit

A45210

according to Dr. James Klim, DDS

Prix: 437,42

Promo
364,50



The Zirconia Finishing Kit was developed by Dr. James Klim, DDS, and is a combination of tungsten carbide instruments, an abrasive, sintered diamonds and polishers. These selected instruments are ideal for pre-sintered zirconia and the finishing of zirconia restorations. All instruments are suitable for use in the laboratory and can be conveniently stored in a high quality bur block.

Le kit Zirconia Finishing, développé avec le Dr. James Klim, DDS, est une combinaison de différentes fraises en carbure de tungstène, d'un abrasif, de diamants frittés et de polissoirs. Ces instruments sélectionnés conviennent de façon optimale pour traiter l'oxyde de zirconium pré-fritté, et ils permettent de réaliser une finition idéale des restaurations en oxyde de zirconium. Tous les instruments conviennent pour être utilisés en laboratoire et ils peuvent être rangés de façon pratique dans le kit de rangement de grande qualité.

	Fig.	Shank ¹	Ref.-No.	Size	Pieces/Kit
	Z0850	FG	806 314 198 324	018	2
	Z850F	FG	806 314 198 314	018	1
	Z0863	FG	806 314 250 324	012	2
	Z863F	FG	806 314 250 314	012	1
	Z0833	FG	806 314 277 324	023	2
	Z833F	FG	806 314 277 314	023	1
	Z801L	FG	806 314 697 324	014	2
	Z0801	FG	806 314 001 324	010	3
	Z838L	FG	806 314 140 526	014	3

¹ 314=FG

	Fig.	Shank ¹	Ref.-No.	Size	Pieces/Kit
	HM489FX	HP	500 104 187 140	023	1
	HM78MF	HP	500 104 257 140	023	1
	S861	HP	807 104 245 524	016	1
	S862	HP	807 104 284 524	031	1
	253G	HP	030 104 045 005	250	1
	253M	HP	030 104 045 003	250	1
	9769F	HP	803 104 000 503	170	1
	9769M	HP	803 104 000 523	170	1
	Z652R*	HP	655 104 199 526	035	1
	9770G*	HP	803 104 303 533	260	1
	105*	HP	100 104 543 005	190	1
	9771G*	HP	803 104 000 534	260	1
	9771M*	HP	803 104 000 524	260	1

¹ 104=HP * for Post-Sintered Zirconia

2663 Twist Polishing Kit

A45417



Prix: 170,78

Promo
142,00



The twist Polishing Kit has been especially developed for simple high-gloss polishing of all composite restorations. The flexible polishing discs make it possible to adapt to any surface structure and also render flawless results in areas that are difficult to reach, such as occlusal surfaces. Due to designs that are gentle on materials, the original surface structure of the restoration is maintained. In addition, the grades of diamond grit separated into two parts provide for short processing times and extremely high levels of durability.

Le kit Twist Polishing Kit a été spécifiquement développé pour le brillantage facile de toutes les restaurations en composites. Les lamelles de polissage flexibles permettent une adaptation à chaque structure de surface et génèrent, même dans les zones difficiles d'accès comme, par exemple, la face occlusale, des résultats impeccables. Grâce à la conception qui ménage le matériau, la structure de surface d'origine de la restauration est conservée. L'échelonnement en deux parties du grain de diamant assure par ailleurs des temps de traitement courts et des durées de vie extrêmement longues.

Diamond polishing system:

Especially for simple polishing of all composite restorations, also in regions difficult to access.

- * Flexible polishing lamellae
- * Specifically for occlusal surfaces
- * Material-saving
- * Short processing times
- * Extremely high service life



	Fig.	Shank ¹	Ref.-No.	Size	Pieces/Kit
	9769M	RA	803 204 000 523	100	2
	9769M	RA	803 204 000 523	140	2
	9769F	RA	803 204 000 503	100	2
	9769F	RA	803 204 000 503	140	2

¹ 204=RA

2571 Twist Finishing Kit

A45926

Prix: 241,64

Promo
201,00



twist finishers

The Meisinger twist Finishers ensure a perfect working result and an extremely smooth surface on composites and other filling materials. Thanks to the unique cutting geometry, the instruments run extremely quietly and cut much finer than standard carbide finishers. The instruments are marked with colour rings for clear differentiation. The Twist Finishing Kit combines all available instruments in one assortment, with the lasered labels of the instruments on the Bur Block a sorting of the twist Finisher is easily possible.

Les fraises de finition Twist de MEISINGER assurent un résultat parfait du travail et une surface extrêmement lisse sur composites et autres matériaux d'obturation. Grâce à leur géométrie de tranchant unique en son genre, les instruments fonctionnent d'une façon extrêmement silencieuse et coupent d'une façon nettement plus fine que les fraises de finition au carbure standard. Pour qu'ils puissent être clairement distingués, les instruments sont identifiés par des bagues de couleur. Le kit Twist Finishing Kit réunit tous les instruments disponibles en un assortiment, et les désignations des instruments marquées au laser sur le porte-fraises permettent un tri sans problème des fraises de finition Twist.

	Fig.	Shank ¹	Ref.-No.	Size	Pieces/Kit
	HM D0132	FG	500 314 699 072	008	1
	HM D132F	FG	500 314 699 042	008	1
	HM D132U	FG	500 314 699 032	008	1
	HM D0133	FG	500 314 159 072	010	1
	HM D133F	FG	500 314 159 042	010	1
	HM D133U	FG	500 314 159 032	010	1
	HM D0134	FG	500 314 164 072	014	1
	HM D134F	FG	500 314 164 042	014	1
	HM D134U	FG	500 314 164 032	014	1
	HM D0135	FG	500 314 166 072	014	1
	HM D135F	FG	500 314 166 042	014	1
	HM D135U	FG	500 314 166 032	014	1
	HM D0379	FG	500 314 277 972	023	1
	HM D379F	FG	500 314 277 942	023	1
	HM D379U	FG	500 314 277 932	023	1

¹ 314=FG

2664 Composite Finishing Kit

A33586

Prix: 202,76

Promo
168,90



These instruments will enable the achievement of the highest surface quality when finishing and polishing composite filling. In addition to the lingual processing of anterior teeth, the occlusal processing of molars and the processing of interproximal surfaces, the possibility of the selective processing of gaps in posterior teeth is also created. The various universally used polishers are an outstanding addition to this set. They also allow the perfect polishing of fissures and the finishing of the labial surfaces of anterior teeth.

Ces instruments permettent d'obtenir de très grandes qualités de surface lors de la finition et du polissage d'obturations en composite. Outre le traitement lingual de dents antérieures, le traitement occlusal de molaires et le traitement de faces interproximales, il est également possible de traiter de façon ciblée les espaces interdentaires de dents latérales. Les différents polissoirs utilisables universellement complètent remarquablement ce kit. Ils permettent par ailleurs de réaliser un polissage parfait de fissures, de même que la finition de faces labiales sur dents antérieures.

2662 Intra Oral Porcelain Adjustment Kit

A29208

Prix: 148,40

Promo
123,50



This set offers a wide selection of special instruments for intraoral processing, finishing and polishing of ceramic restorations. The 820F diamond grinder allows the safe and fast removal of excess material in the interdental region, the 890F fine-grained diamond was designed to improve the anatomy and interspaces in the molar region, Figure 833F offers the opportunity to efficiently finish both anterior teeth (palatal / lingual) and occlusal surfaces as well as molars. The set includes diamond ceramic polishers in two shapes and three different grain types for perfect polishing of the restorations.

Ce kit offre une large sélection d'instruments spéciaux pour le traitement, la finition et le polissage intrabuccaux de restaurations en céramique. L'abrasif diamanté 820 F permet de retirer avec fiabilité et rapidement l'excès de matériau dans la région interdentaire. Pour améliorer l'anatomie et les espaces interdentaires dans la région des molaires, le diamant à grain fin 890F a été créé. La figure 833F permet une finition efficace aussi bien des dents antérieures (palatinales / linguales) que des faces occlusales, mais également des molaires. Pour un polissage parfait des restaurations, des polissoirs diamant-céramique sont présents dans le kit sous deux formes et dans trois types de grains différents.

	Fig.	Shank ¹	Ref.-No.	Size	Pieces/Kit
	830F	FG	806 314 257 514	023	1
	833F	FG	806 314 277 514	023	1
	HM 246U	FG	500 314 296 031	009	1
	HM 247U	FG	500 314 195 031	009	1
	HM 274U	FG	500 314 274 032	016	1
	9712M	RA	803 204 243 523	040	1
	9714M	RA	803 204 030 523	060	1
	9718M	RA	803 204 303 523	100	1
	9712F	RA	803 204 243 513	040	1
	9714F	RA	803 204 030 513	060	1
	9718F	RA	803 204 303 513	100	1

¹ 314=FG, 204=RA

	Fig.	Shank ¹	Ref.-No.	Size	Pieces/Kit
	820F	FG	806 314 465 514	016	1
	833F	FG	806 314 277 514	023	1
	890F	FG	806 314 160 514	010	1
	9743G	RA	803 204 243 533	040	1
	9744G	RA	803 204 030 533	060	1
	9743M	RA	803 204 243 524	040	1
	9744M	RA	803 204 030 524	060	1
	9743F	RA	803 204 243 503	040	1
	9744F	RA	803 204 030 503	060	1

¹ 204=RA, 314=FG

2582 Temporary Solution Kit

A45928 developed with ZTM Rainer Michel

Prix: 128,18

Promo
106,50



The temporary solution Kit is used for the simple processing and creation of provisionals in the dental practice.

Le kit Temporary Solution Kit sert à traiter et à créer facilement des provisoires au cabinet dentaire.

2638 Acrylic Adjustment Kit

A36416





Prix: 148,40

Promo
123,50





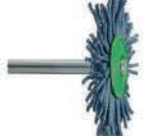





The Acrylic Adjustment Kit correction set offers a comprehensive instrument kit for the quick and easy implementation of various corrections to synthetic materials in the practice. The innovative gear geometry of the hard metal burs included in the range of products thus already ensures the achievement of unusually smooth surfaces with the use of these instruments. The various synthetic material polishers are the result of years of development and are characterized by exceptionally high performance and durability.

Le kit Acrylic Adjustment Kit offre des instruments complets pour réaliser facilement et rapidement les corrections les plus variées sur le synthétique, au cabinet dentaire. L'innovante géométrie de denture des fraises carbure de tungstène contenues dans l'assortiment assure à cet égard, dès l'utilisation de ces instruments, l'obtention de surfaces lisses auxquelles on n'était pas habitué dans le passé. Les différents polissoirs pour synthétiques sont le résultat de longues années de travaux de développement et ils sont caractérisés par des performances et une durabilité exceptionnelles.

	Fig.	Shank ¹	Ref.-No.	Size	Pieces/Kit
	HM 79GX	HP	500 104 194 190	040	1
	HM 488FX	HP	500 104 184 140	016	1
	402	HP	030 104 543 514	220	1
	110	HP	100 104 543 000	190	1
	150	HP	080 104 045 000	220	1

¹ 104=HP

	Fig.	Shank ¹	Ref.-No.	Size	Pieces/Kit
	HM 79FX	HP	500 104 194 140	040	1
	HM 251FX	HP	500 104 274 140	060	1
	9572V	HP	658 104 201 536	150	1
	9573V	HP	658 104 273 536	100	1
	9572P	HP	658 104 201 534	150	1
	9573P	HP	658 104 273 534	100	1
	9572H	HP	658 104 201 524	150	1
	9573H	HP	658 104 273 524	100	1

¹ 104=HP

ENDO2 Endo Access Bur Kit

A45931

Prix: 196,62

Promo
163,50

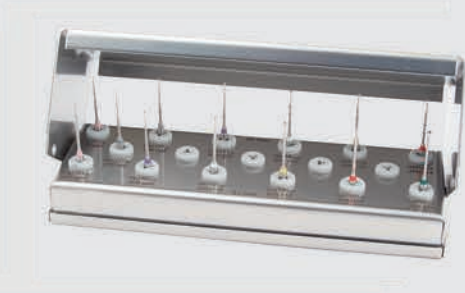

Improve your endodontic access by improving visibility with Meisinger's Endo Access Bur Kit. This kit is a complete set of Meisinger Endo Access Burs designed for safe access into the root canal. Unlike traditional burs that obstruct your vision into the working area, these burs have long, thin necks allowing for an excellent, unobstructed view. These unique burs allow the practitioner to safely and easily remove dentinal triangles and flare the canal orifice for optimal straight line access into the root canal. Due to their very stable construction, the Endo Access Burs have optimal low-vibration concentricity and are designed to create less heat and debris than traditional ultrasonic tips. The color bands on the shank allow for quick identification and selection of the instruments.

Optimisez le processus de traitement endodontique coronaire, avec le kit Endo Access Bur Kit de MEISINGER. Ce kit regroupe toutes les fraises Endo Access Burs de Meisinger permettant d'accéder en toute sécurité au canal radiculaire. À l'encontre des forets standard, qui restreignent la vision de la zone de travail, les fraises Endo Access Burs permettent une vision illimitée, grâce à leur collet long et mince. Ces forets, uniques en leur genre, permettent à l'utilisateur d'ouvrir le canal et d'élargir l'ouverture, facilement et avec fiabilité, pour un accès idéal et rectiligne au canal radiculaire.

2575 Periimplantitis Kit

A45927

Prix: 166,12

Promo
138,00



The Periimplantitis Kit contains eight perfectly matched tungsten carbide finishing burs in egg and flame shapes for the ideal peri-implantitis treatment. Both shapes come in two sizes and each in standard and ultra-fine toothing. The shapes, sizes and toothings of the working parts are perfectly suited for the intraoral treatment of titanium and for different shapes of implant neck and shoulder. All finishers have an extra-long FG shank (total length 32 mm) which allows particularly the treatment of difficult-to-access deep areas. For the peri-implantitis treatment, the finishers are used clockwise and are guided around the exposed implant counterclockwise so the implant surface is smoothed.

Le kit Péri-implantite contient huit fraises de finition au carbure parfaitement adaptées entre elles, sous une forme ovoïde et une forme de flamme, pour le traitement optimal de la péri-implantite. Les deux formes sont présentes en deux tailles et chacune dans une denture standard et une denture ultra fine. Les formes, tailles et dentures des parties travaillantes conviennent de façon optimale pour le traitement intrabuccal du titane, et pour différentes formes de pourtour et d'épaulement d'implant. Toutes les fraises de finition contenues dans le kit possèdent une tige FG extra longue (longueur totale 32 mm) permettant d'atteindre des zones profondes et particulièrement difficiles à atteindre.

	Fig.	Shank ¹	Ref.-No.	Size	Pieces/Kit
	HM191A	RA L	500 205 004 006	005	1
	HM191A	RA L	500 205 004 006	006	1
	HM191A	RA L	500 205 004 006	008	1
	HM191A	RA L	500 205 004 006	010	1
	HM191A	RA L	500 205 004 006	012	1
	HM191A	RA L	500 205 004 006	014	1
	HM191A	RA L	500 205 004 006	018	1
	HM191A	RA XL	500 206 004 006	005	1
	HM191A	RA XL	500 206 004 006	006	1
	HM191A	RA XL	500 206 004 006	008	1
	HM191A	RA XL	500 206 004 006	010	1
	HM191A	RA XL	500 206 004 006	012	1
	HM191A	RA XL	500 206 004 006	014	1

¹ 205=RA L, 206=RA XL

	Fig.	Shank ¹	Ref.-No.	Size	Pieces/Kit
	HM379	FGXXL	500 317 277 072	014	1
	HM379	FGXXL	500 317 277 072	023	1
	HM48L	FGXXL	500 317 249 072	014	1
	HM48L	FGXXL	500 317 249 072	023	1
	HM379U	FGXXL	500 317 277 032	014	1
	HM379U	FGXXL	500 317 277 032	023	1
	HM48LU	FGXXL	500 317 249 032	014	1
	HM48LU	FGXXL	500 317 249 032	023	1

¹ 317=FGXXL

BC04 Black Cobra Complete Crown Removal Kit

A45418

Prix: 131,96

Promo

109,90



The BC04 Black Cobra Complete Crown removal Kit is the only kit you will need for the removal of any dental restoration. Included in the kit are six Black Cobra diamonds for efficiently removing the hardest of crown materials such as Zirconia, as well as four special carbides for cutting through metal substructures or PFM crowns.

Le kit BC04 Black Cobra Complete Crown Removal Kit est un kit unique dont vous avez besoin pour retirer toute restauration dentaire. Ce kit contient six diamants Black Cobra à hautes performances, qui sont capables de détacher même le matériau de couronnes le plus dur. Les quatre instruments au carbure contenus dans le kit conviennent de façon optimale pour détacher les chapes métalliques ou les couronnes céramo-métalliques.

JK05 Acryl / Resin Universal Kit

A45929

developed with Dr. James Klim, DDS

Prix: 125,00











Promo

105,00



The Acryl/ Resin Universal Kit developed by Dr. James Klim, DDS, is especially suitable for the treatment and polishing of denture plastics, splints and aligners. With the included tungsten carbide instruments, it is easy to work out rails and dentures. The fiber fleece brushes provide a high-quality finish without overheating the material and damaging the surface. For a less surface, is the polisher 9573H included in the kit. All instruments are suitable for extraoral use and can be conveniently stored in the bur block.

Le kit Acryl/ Resin Universal Kit, développé avec le Dr. James Klim, DDS, convient spécifiquement pour le traitement et le polissage de synthétiques de prothèses, rails et gouttières. Les fraises au carbure contenues dans le kit permettent de traiter sans problème les rails et les prothèses. Les brosses en non tissé en fibres permettent d'obtenir un lustre de tout premier ordre, sans surchauffer le matériau ni endommager la surface. Le polissoir 9573H, pour une finition de surface impeccable, est contenu dans le kit. Tous les instruments conviennent pour être utilisés en extrabuccal et ils peuvent être rangés de façon pratique dans le porte-forets de grande qualité.

	Fig.	Shank ¹	Ref.-No.	Size	Pieces/Kit
	HMG34RS	FG	500 314 138 008	012	1
	HM21RX	FG	500 314 139 019	012	1
	HM31A	FG	500 314 139 008	012	1
	HM31C	FG	500 314 134 015	012	1
	B850	FG	809 314 198 544	016	1
	B850	FG	809 314 198 544	018	1
	B850	FG	809 314 198 544	021	1
	B850	FG	809 314 198 544	025	1
	B852	FG	809 314 199 544	016	1
	B852	FG	809 314 199 544	018	1

¹ 314=FG

	Fig.	Shank ¹	Ref.-No.	Size	Pieces/Kit
	HM251FF	HP	500 104 274 181	060	1
	HM79FF	HP	500 104 194 181	040	1
	HM515	HP	500 104 467 211	023	1
	9573H	HP	658 104 273 524	100	1
	253	HP	030 104 045 000	250	1
	253M	HP	030 104 045 003	250	1
	253G	HP	030 104 045 005	250	1

¹ 104=HP

Benex®-Control

Root Extraction System | developed with Dr. Benno Syfrig

Benex®-Control eignet sich hervorragend zum kontrollierten und sicheren Extrahieren von Zahnwurzeln und Zahnwurzelfragmenten, sodass die herkömmliche Methode der Extraktion mit Zange und Hebel vermieden werden kann. Dank der innovativen Konstruktion des Extraktors lässt sich die Wurzel ohne Verletzung von Knochen und Weichgewebe sehr leicht und besonders kontrolliert entfernen. Um eine optimale, vertikale Kraftübertragung zu garantieren, muss eine plane Ebene zur Auflage des Extraktors vorliegen. Die speziell für diesen Zweck entwickelte Quadrantenstütze bietet eben diese optimale Auflagefläche. Dabei schützt sie vorhandene Restbeziehung und bietet insbesondere bei zahnlosen Verhältnissen eine stabile Auflage für den Extraktor.

Benex®-Control is outstandingly suitable for the controlled and safe extraction of dental roots and dental root fragments, so the conventional extraction method using forceps and leverage can be avoided. Thanks to the innovative construction of the extractor, the root can be easily removed in a particularly controlled manner without damaging bone or soft tissue. To guarantee an optimal vertical transmission of force, there must be a flat area providing a supporting surface to the extractor. The quadrant support was developed specifically to provide this optimal support while also protecting existing dentition and providing support for the extractor in case of edentulous circumstances.



Anwendungsvideo
Application Video

Art.-No. CBE00

A42781
Prix: 1661,00

Promo
1395,00

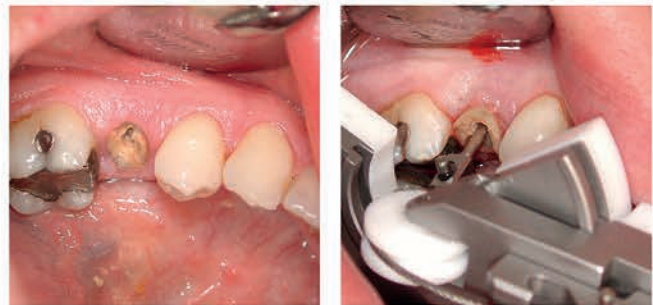

© Dr. Benno Syfrig

	Diamantinstrument Diamond instrument	Pilobohrer Pilot burs	Extraktionschrauben Extraction screws				
Fig.	859L*	A2001	B2001	BE001230 060	BE001230 070	BE001230 080	BE001230 085
Shank ¹	204	205	205	-	-	-	-
Size ²	010	013	016	-	-	-	-
Length mm	12.0	15.0	15.0	10.0	16.0	10.0	16.0
Δ	-	-	-	1.3	1.3	1.8	1.8
*□	1.0	1.3	1.6	1.6	1.6	2.1	2.1

¹ 204=RA, 205=RA L ² Largest working part diameter in 1/10 mm
 Δ Minimaldurchmesser Minimal diameter □ Außendurchmesser External diameter

* Bei Wiederverwendung von Einmalprodukten kann ein Infektionsrisiko nicht ausgeschlossen werden und eine risikofreie Funktionssicherheit nicht gewährleistet werden. With the reuse of disposable products, the risk of infection cannot be excluded and a risk-free functional safety cannot be guaranteed.

	Endrehhilfe Insertion aid	Zugselle ¹ Traction stringer	Schutzkappe Protecting cap	Extraktor ¹ Extractor	Quadrantenstütze ¹ Quadrant support		
Fig.	BE001230 045	BE001230 055	BE001230 020	BE001230 021	BE001230 SK60	BE001230 010	BE001230 090
Length mm	8.2	18.2	48.0	39.0	8.0	129.0	-

¹ Illustrated 1:2 ² Illustrated 1:3 Δ Minimaldurchmesser Minimal diameter □ Außendurchmesser External diameter

Master-Pin-Control

Pin System for Membrane Fixation | developed with Dr. Istvan Urban

Master-Pin-Control ist speziell für die Fixation resorbierbarer, nicht-resorbierbarer und titanverstärkter Membranen entwickelt worden. Da die Pins über ein zusätzliches Mini-Gewinde verfügen, stellen sie ein Hybrid aus Schraube und Pin dar. Durch das Gewinde vergrößert sich die Oberfläche der Pins, wodurch eine deutlich erhöhte Stabilität erreicht wird. Außerdem lassen sich die Pins dank des Gewindes und eines einzigartigen Kopf-Designs sicher und leicht entfernen, was gerade nach einer erfolgreichen Einheilungszeit von besonderer Bedeutung ist. Mit ihrer scharfen Spitze und dem sehr stabilen Schaft lassen sie sich einfach und präzise in den kortikalen Knochen einbringen.

Master-Pin-Control is designed especially for the fixation of resorbable, non-resorbable and titanium reinforced membranes. Since the pins have an extra mini-thread, they are a hybrid between a screw and a pin. The thread increases the surface of the pins and thus offers much more stability. In addition, due to the thread and a unique head-design, the pins can be removed easily and safely which is especially important after a successful healing period. With their sharp tip and very stable shank, they can be inserted easily and precisely into dense cortical bone.

A43341
Prix: 1065,48

Promo
895,00

34x Pins



Art.-No. BMP00

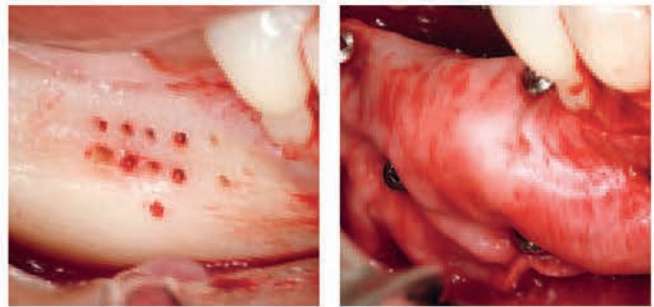

© Dr. Istvan Urban

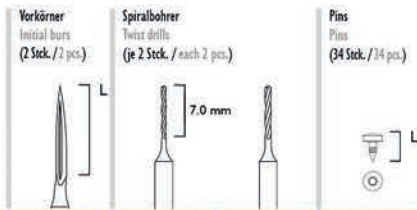

Fig.	186RF	203RF	203RF	MP10*
Shank ¹	204	205	205	-
Size ²	018	006	008	-
Length mm	12.0	7.0	7.0	3.65
Δ	-	-	-	0.87
* □	1.8	0.6	0.8	0.95

¹ 204=RA, 205=RA L ² Largest working part diameter in 1/10 mm
 Δ Minimaldurchmesser Minimal diameter □ Außendurchmesser External diameter

* Bei Wiederverwendung von Einmalprodukten kann ein Infektionsrisiko nicht ausgeschlossen werden und eine risikofreie Funktionssicherheit nicht gewährleistet werden. With the reuse of disposable products, the risk of infection cannot be excluded and a risk-free functional safety cannot be guaranteed.

Schraubendreher für Pin
Screwdriver for Pin

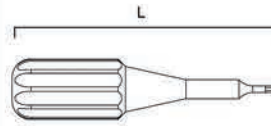

Fig. MP11
illustrated 1:1 (Lenght mm: 35.0)

Pin-Halter
Pin holder

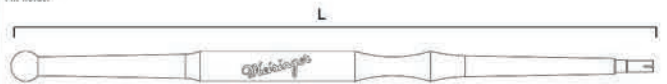

Fig. MP12
illustrated 1:2 (Lenght mm: 170.0)

Fixierhalter
Fixing holder



Fig. MP14
illustrated 1:2 (Lenght mm: 165.0)



A42413
Prix: 772,62

Master-Pin-Control Basic

Auch mit 10 Pins erhältlich. Also available with 10 pins.

Promo
649,00

10x Pins

Art.-No. BMPBA

STERILIZABLE BUR BLOCKS, ALUMINIUM |

These products are manufactured from colored anodized aluminum. When using chemical cleaning solutions, a slight discoloring may occur. Therefore, when using cleaning solution (recommended ph-value 5.5-8.5), it is advisable not to use those which have high contents of alkaline or acid.

The following sterilization method can be used without hesitation: Sterilizing with humid heat in the autoclave (e.g. at 134 °C / 273 °F). Please follow the operating instructions of the appliance according to the manufacturer and observe the recommendations regarding the duration of sterilization.

These Bur Blocks are only suitable for instruments with the specified shanks. Instruments with shorter shanks are not adequately secured and may fall out.

BUR CLEANING BRUSHES



A41409
Brossette fraises laiton

Prix: 2,20

Par 2 : 1,95 par pièce



A41410
Brossette fraises nylon

Prix: 2,00

Par 2 : 1,95 par pièce

The following application tips apply for aluminum products:

- Observe the regulations precisely of the disinfectant manufacturer: some are not suitable for aluminum!

EXPLANATION OF DIMENSIONS |



BUR BLOCKS, STERILIZABLE, ORANGE |

Réduction de 16%

OR100GEL A45460



ca. B 41 x H 33 x T 25 mm Prix: 38,08

For 5 RA instruments (205) and 10 FG instruments (316, 317)

Promo
31,75

OR102GEL A45461



ca. B 54 x H 30 x T 25 mm Prix: 36,52

For 7 RA instruments (204, 205) and 14 FG instruments (314, 315, 316)

Promo
30,60

OR202GEL A45462



ca. B 41 x H 33 x T 25 mm Prix: 38,08

For 15 RA instruments (205)

Promo
31,75



* Observe suitability of the material for means used (ph value, suitability for Al)

OR300GEL A45463



ca. B 41 x H 30 x T 25 mm Prix: 30,86

For 15 FG instruments (314, 315, 316)

Promo
25,90

OR302GEL A45464



ca. B 54 x H 30 x T 25 mm Prix: 36,52

For 21 FG instruments (314, 315, 316)

Promo
30,65

OR603GEL A45465



ca. B 73 x H 30 x T 25 mm Prix: 38,08

For 6 RA instruments (204, 205) and 12 FG instruments (314, 315, 316)

Promo
31,75

OR606GEL A45472



ca. B 73 x H 30 x T 25 mm Prix: 38,08

For 30 FG instruments (314, 315, 316)

Promo
31,75

OR638GEL A45466



ca. B 85 x H 29 x T 39 mm Prix: 46,22

For 10 RA instruments (204, 205) and 10 FG instruments (314, 315, 316)

Promo
38,75

OR700GEL A45467



ca. B 50 x H 69 x T 40 mm Prix: 31,96

For 15 Handpiece instruments (104, 105)

Promo
26,75

OR702GEL A45468



ca. B 100 x H 69 x T 40 mm Prix: 46,22

For 23 Handpiece instruments (104, 105)

Promo
38,75



* Observe suitability of the material for means used (ph value, suitability for AI)

BUR BLOCKS, STERILIZABLE, BLUE |

BL300GEL A45441



ca. B 41 x H 30 x T 25 mm Prix: 30,86

For 15 FG instruments (314, 315, 316)

Promo
25,90

BL700GEL A45442



ca. B 50 x H 69 x T 40 mm Prix: 31,96

For 15 Handpiece instruments (104, 105)

Promo
26,75

BL702GEL A45443



ca. B 100 x H 69 x T 40 mm Prix: 46,22

For 23 Handpiece instruments (104, 105)

Promo
38,75

BUR BLOCKS, STERILIZABLE, GREEN |

GR102GEL A45469



ca. B 54 x H 30 x T 25 mm Prix: 36,52

For 7 RA (204, 205) instruments and 14 FG instruments (314, 315, 316)

Promo
30,65

GR202GEL A45458



ca. B 41 x H 33 x T 25 mm Prix: 38,08

For 15 RA instruments (205)

Promo
31,75

GR300GEL A45459



ca. B 41 x H 30 x T 25 mm Prix: 30,86

For 15 FG instruments (314, 315, 316)

Promo
25,90

GR606GEL A34742



ca. B 73 x H 30 x T 25 mm Prix: 38,08

For 30 FG instruments (314, 315, 316)

Promo
31,75

For all |



* Observe suitability of the material for means used (ph value, suitability for Al)

STAINLESS STEEL BUR BLOCKS, NON- CORROSIVE, STERILIZABLE |

BS441 A45453



ca. B 60 x H 40 x T 45 mm

Prix: 33,70

For 8 RA instruments or 8 FG instruments

Promo
28,25

BS541 A45456



ca. B 120 x H 40 x T 45 mm

Prix: 38,40

For 18 RA instruments or 18 FG instruments

Promo
32,25

BS440 A45452



ca. B 60 x H 40 x T 45 mm

Prix: 33,70

For 12 RA instruments or 12 FG instruments

Promo
28,25

BS540 A45455



ca. B 120 x H 40 x T 45 mm

Prix: 38,40

For 24 RA instruments or 24 FG instruments

Promo
32,25

BS470 A45454



ca. B 60 x H 65 x T 45 mm

Prix: 33,70

For 12 Handpiece instruments (103 & 104)

Promo
28,25

BS570 A45457



ca. B 120 x H 65 x T 45 mm

Prix: 38,40

For 24 Handpiece instruments (103 & 104)

Promo
32,25

BS151*
A45446



ca. B 162 x H 51 x T 85 mm

Prix: 97,30

For 40 RA instruments or 40 FG instruments

Promo
81,50

BS141*
A45445



ca. B 125 x H 40 x T 90 mm

Prix: 64,88

For 20 RA instruments or 20 FG instruments

Promo
54,50

BS171*
A45448



ca. B 125 x H 70 x T 90 mm

Prix: 64,88

For 20 Handpiece instruments

Promo
54,50



* The base must be removed prior to cleaning. |

Réduction de 16%

Meisinger

BUR BLOCKS, NON STERILIZABLE, PLEXIGLASS |

2807 A33555



ca. B 163 x H 20 x T 107 mm

Prix: 56,65

Base – For 50 Handpiece or 50 RA instruments

Promo
47,50

D2807 A31162

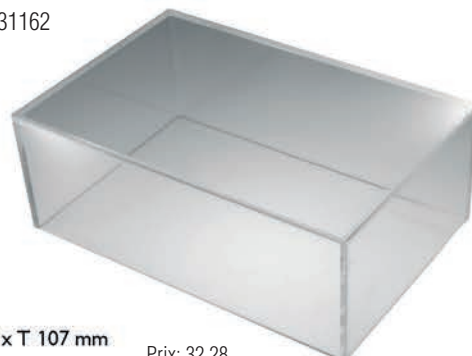

ca. B 163 x H 62 x T 107 mm

Prix: 32,28

Cover HP

Promo
27,00

2808 A28806

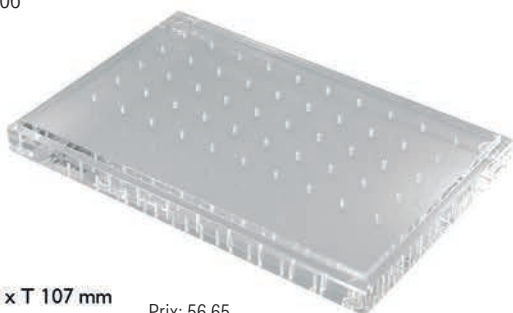

ca. B 163 x H 20 x T 107 mm

Prix: 56,65

Base – For 50 FG instruments

Promo
47,50

D2808 A30233



ca. B 163 x H 32 x T 107 mm

Prix: 32,28

Cover FG

Promo
27,00

2813 A37349

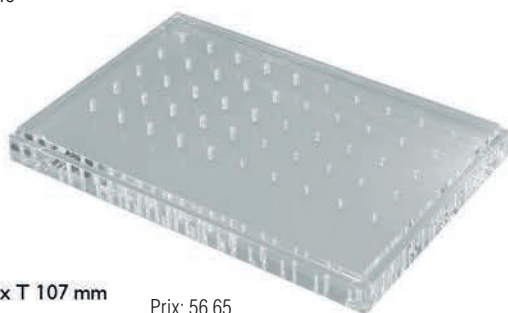

ca. B 163 x H 20 x T 107 mm

Prix: 56,65

Base – For 25 Handpiece or 25 RA instruments and 25 FG instruments

Promo
47,50

D2813 A33554



ca. B 163 x H 43 x T 107 mm

Prix: 32,28

Cover RA

Promo
27,00



Souhaitez-vous une présentation complète de la gamme Meisinger dans votre cabinet ?

Contactez-nous au 03 450 93 20 ou par mail : marketing@denta.be



Les prix sont en euro hors TVA et par pièce ou par unité de vente. Sous réserve de fautes de frappe ou de composition. Les photos sont sans engagement. Aucun frais d'administration ou de transport ne sera compté pour les commandes au dessus de 150 euros hors TVA. Les promotions sont valables du 01/03/2024 au 31/12/2024. Offres valables jusqu'à épuisement du stock et non cumulables avec d'autres actions.

Denta nv, Heiveldekens 2, 2550 Kontich, www.denta.be

Comptoir Dentaire de Bruxelles, EEBIC building, Allée de la Recherche 12 bte 30.28, 1070 Anderlecht, www.comptoir-dentaire.be

COMPTOIR DENTAIRE DE BRUXELLES

