



TRIPLE BYPASS SYSTEM

ASSEMBLY INSTRUCTIONS



TRIPLE BYPASS SYSTEM Recommended Tools

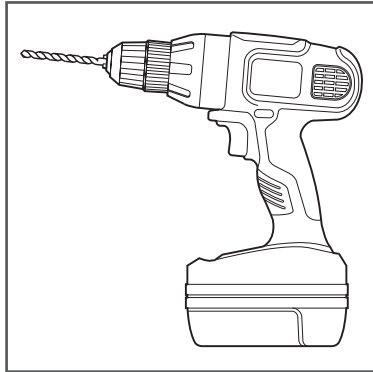

Drill with 1/4" Drill Bit
and Phillips Screw Bit

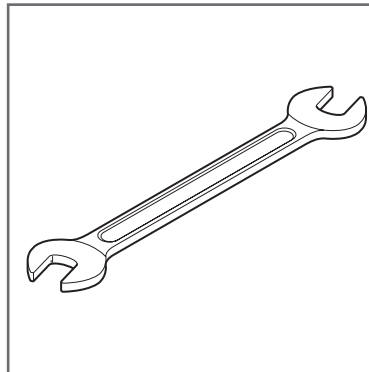

7/16" Combination
Wrench

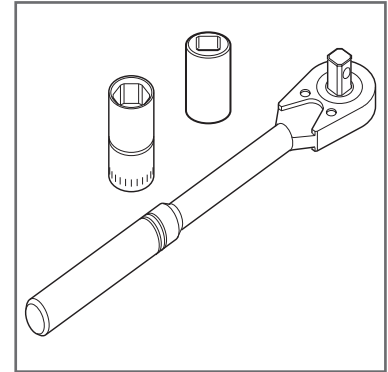

Socket Wrench with
7/16 and 9/16" Socket

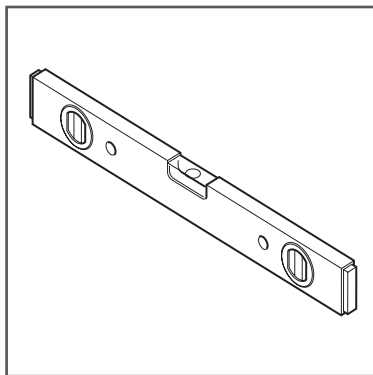

Level

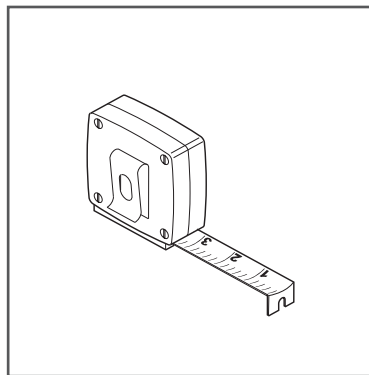

Tape Measure

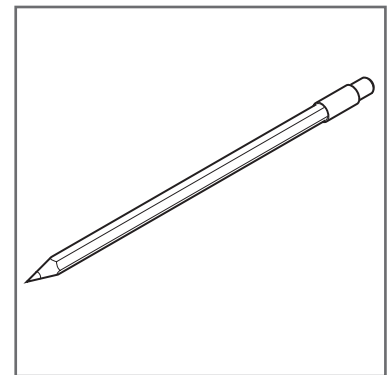

Pencil

**USE TEAMWORK - WE RECOMMEND
TWO PEOPLE FOR THIS BUILD.**

TRIPLE BYPASS SYSTEM Parts

NOTE:
THE FOLLOWING INSTRUCTIONS ARE FOR FLAT TRACK TRIPLE BYPASS SYSTEMS ONLY.
DO NOT ATTEMPT TO USE ON TUBE, BOX, BYPASS, J TRACKS, OR CEILING MOUNT TRACK

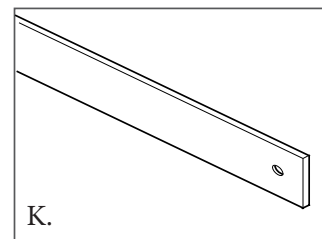
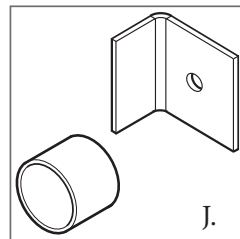
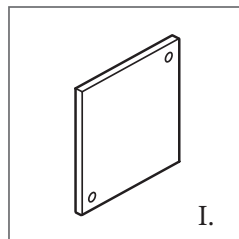
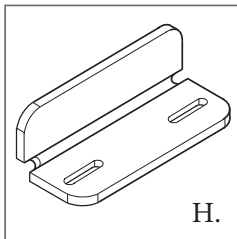
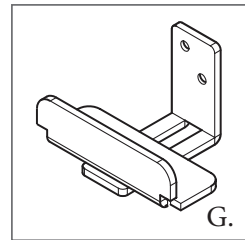
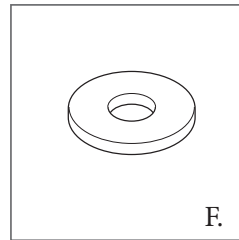
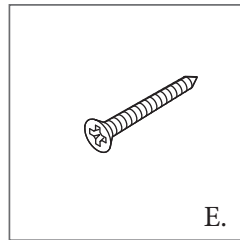
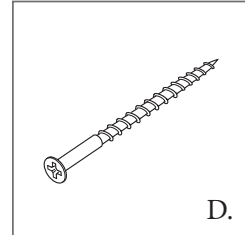
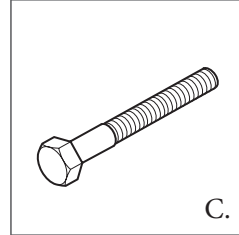
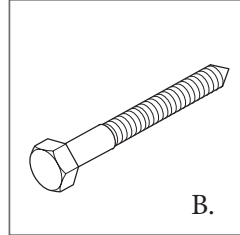
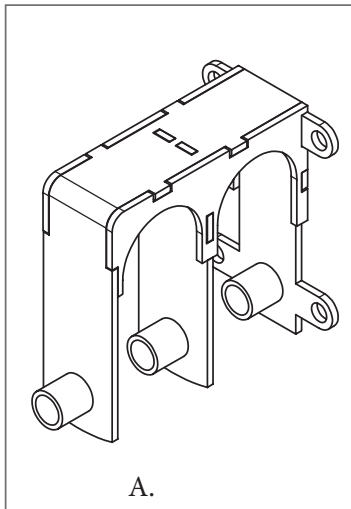

PARTS

- A. Bypass Bracket
- B. Lag Screw
- C. Lag Bolt
- D. 3" Wood Screw
- E. 1" Phillips Screw
- F. Washer
- G. Come-Along Door Guide (Optional)
- H. Door Guide
- I. End Plate
- J. Hard Stop & Rubber Bumper
- K. Track

FIRST THINGS FIRST

Check to see if the floor below the track area is level. If the floor rises more than 1/2" the door may rub or not slide open completely. If the floor is not level, measure from the highest point of the floor surface to the recommended track placement and adjust track placement accordingly.

It will be necessary to install a header for the track when wall studs are not lining up with the track and door installation. Headers provide the necessary strength and stability for the track and door.

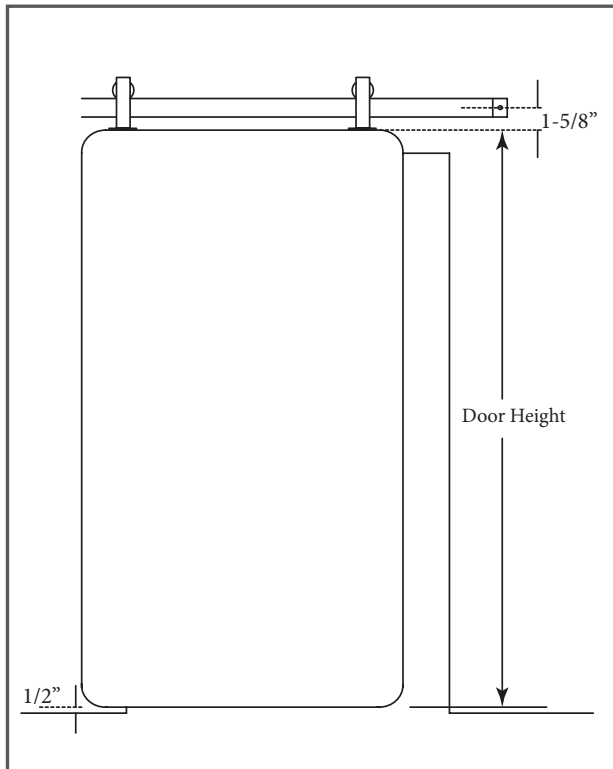

Figure 1

TRACK & DOOR INSTALLATION PREP

1. To determine where the track should be installed, first measure the height of the door, then add 2-1/8" to the door length. 1/2" will be for the clearance between the bottom edge of the door and the floor. 1-5/8" will be from the top edge of the door to the center of the track. (Figure 1).

2. Using a level and a pencil, make a line above the doorway the same length as the track.

HEADER INSTALLATION

NOTE:
The header should be 6" tall and 4" longer than the track.

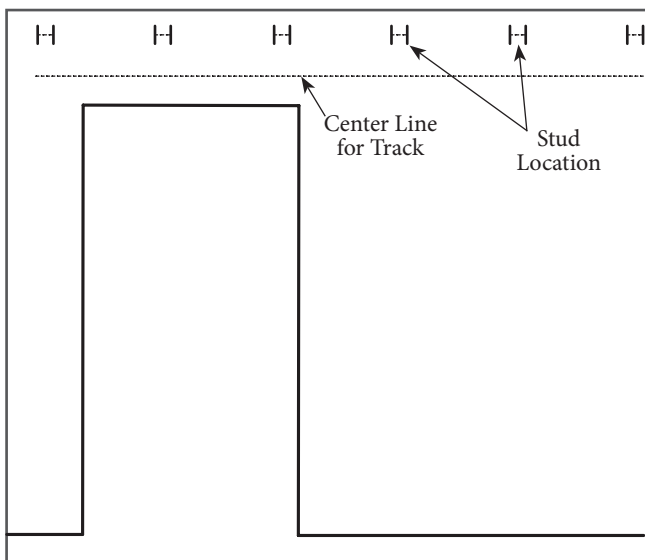

Figure 2

3. Using a stud finder, locate the studs along the area the header will be installed. Mark stud locations with a pencil (Figure 2).

TRIPLE BYPASS SYSTEM Assembly Instructions

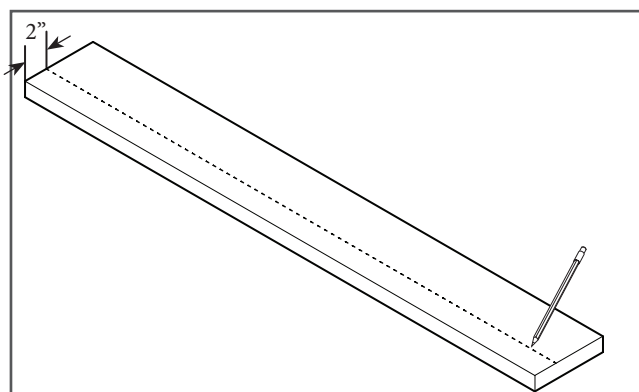

Figure 3

4. Lay the header on a flat clean surface. Using a measuring tape, measure 2" from the bottom of the header. Draw a line the length of the header with a pencil (Figure 3).

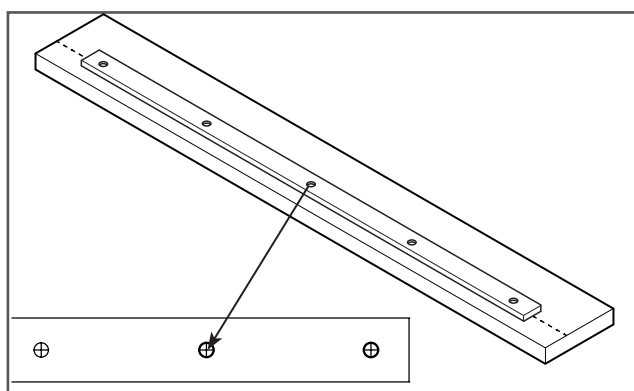

Figure 4

5. Lay the track (K.) on top of the header, centering it with the line drawn on the header. Ensure the track is 2" from either end of the header. Using a pencil, mark the hole positions in the track onto the header (Figure 4). Set the track aside.

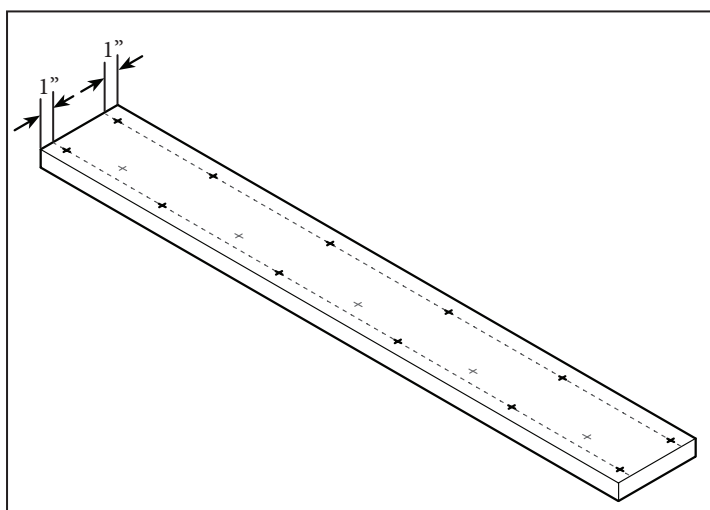

Figure 5

6. Mark the center of the stud onto the header. Mark 1" from the top edge and 1" above the bottom edge (Figure 5).

TRIPLE BYPASS SYSTEM Assembly Instructions

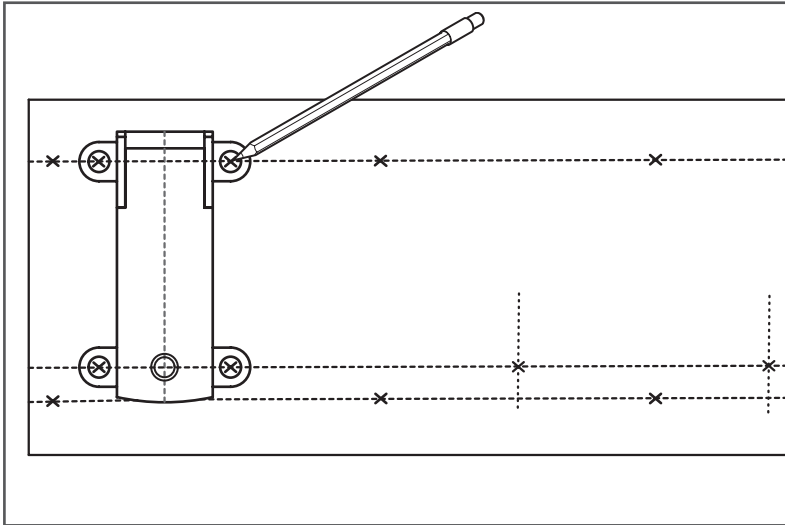

Figure 6

6. Center the bypass bracket (A.) on the first vertical pencil line with the bottom of the bracket edge touching the bottom horizontal pencil line. Mark the center of each of the four holes in the bracket back. Repeat for remaining brackets.

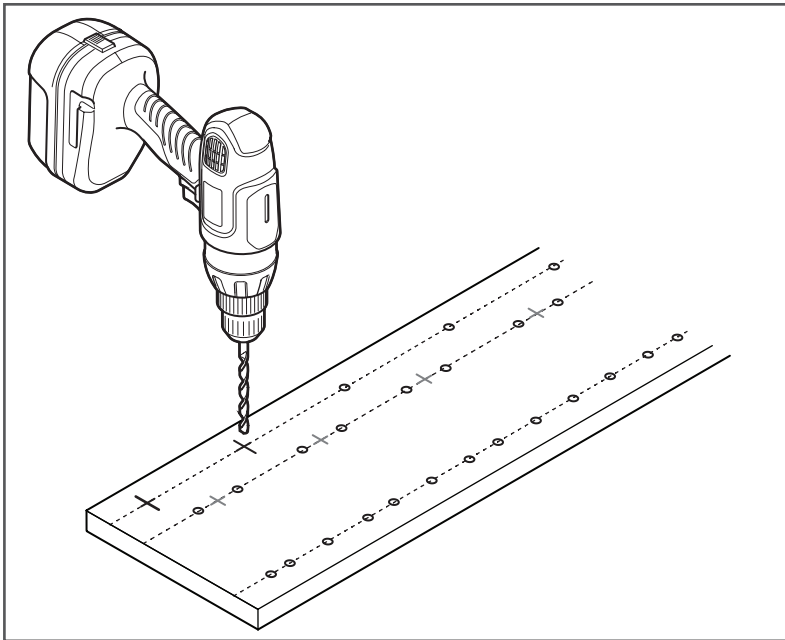

Figure 7

7. Drill out the marked holes using a drill with a 1/4" drill bit (Figure 7).

8. Align the line on the wall with the line made on the header in step 4. Ensure pilot holes align with wall studs (Figure 8).

9. Install header using 3" wood screws (D.) (Figure 8).

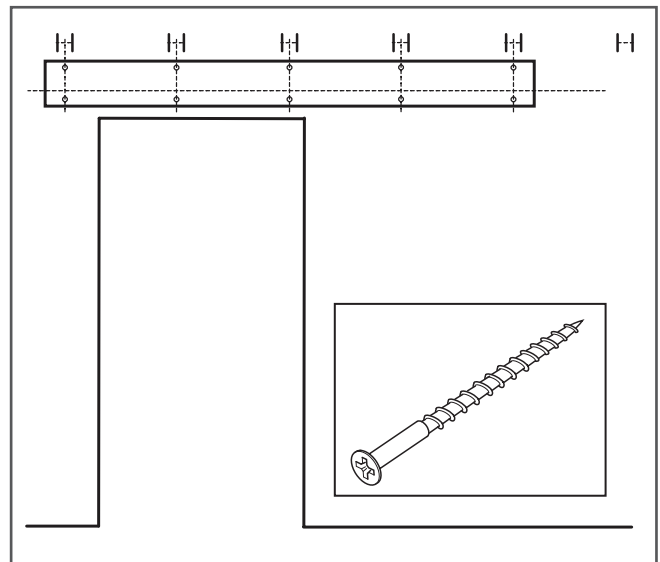

Figure 8

TRIPLE BYPASS SYSTEM Assembly Instructions

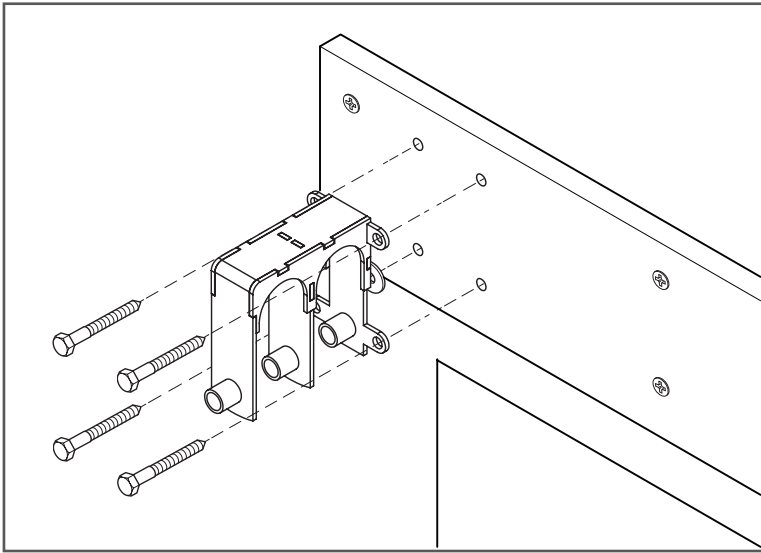

Figure 9

10. Install brackets (A.) with a socket wrench using lag screws (B.) (Figure 9).

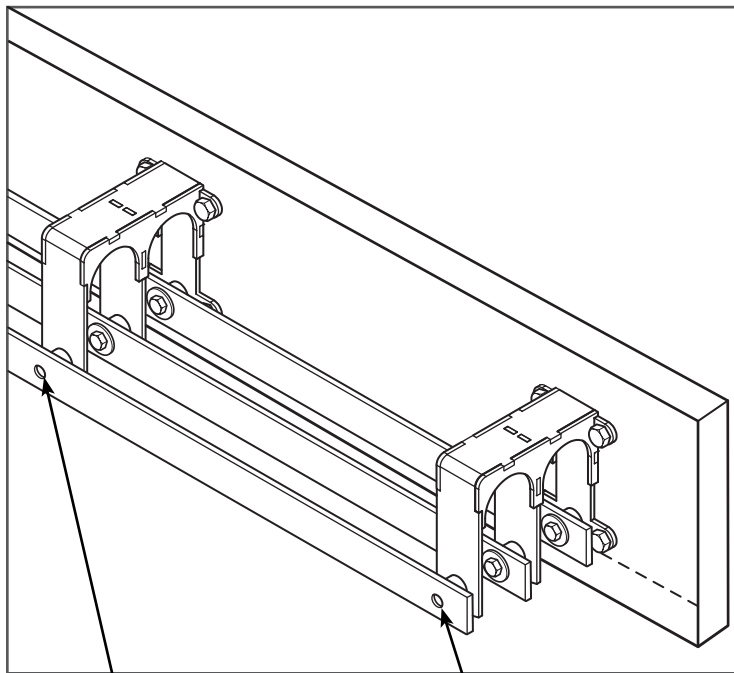

Figure 10

11. Beginning with the track closest to the wall, install each track completely before moving on to the next track (Figure 10).

11a. For brackets between end brackets, install each track using a socket wrench and one lag screw (B.) (Figure 10a).

11a. For brackets end brackets, install each track using a socket wrench and one lag screw (B.) (Figure 10b).

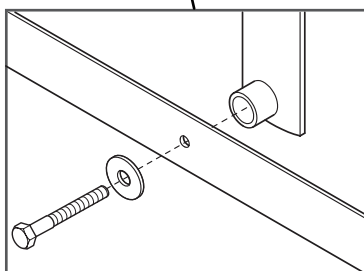

Figure 10a

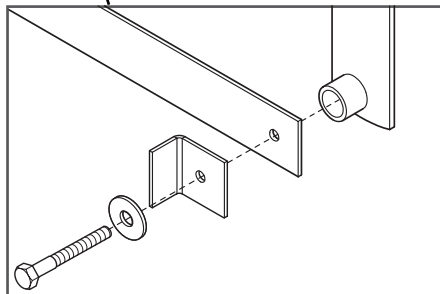

Figure 10b

TRIPLE BYPASS SYSTEM Assembly Instructions

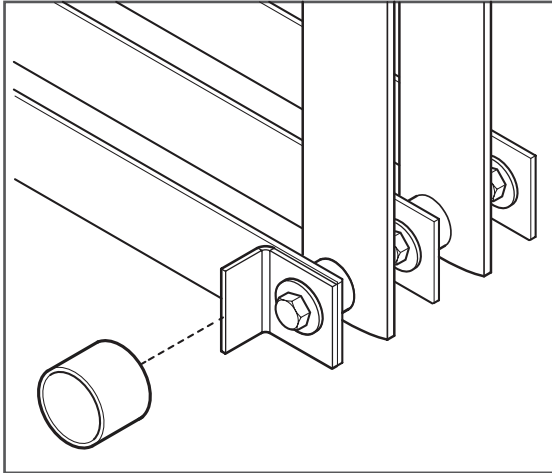

Figure11

12. Stretch rubber bumper (J.) over hard stops. Repeat for the hard stops on the other end of the track (Figure 11).

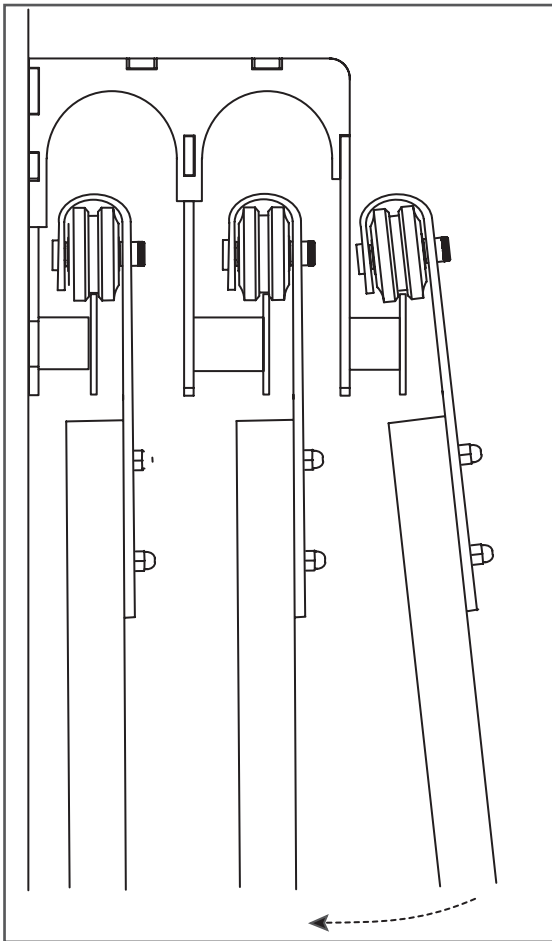

Figure 12

13. Hang the doors (Figure 12).

PANEL/DOOR GUIDE INSTALLATION

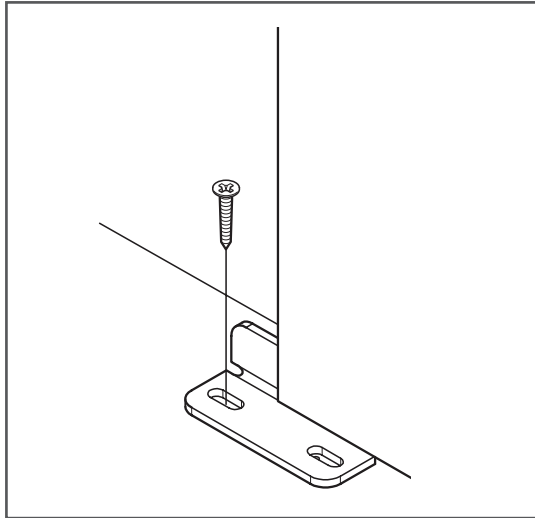

Figure 13

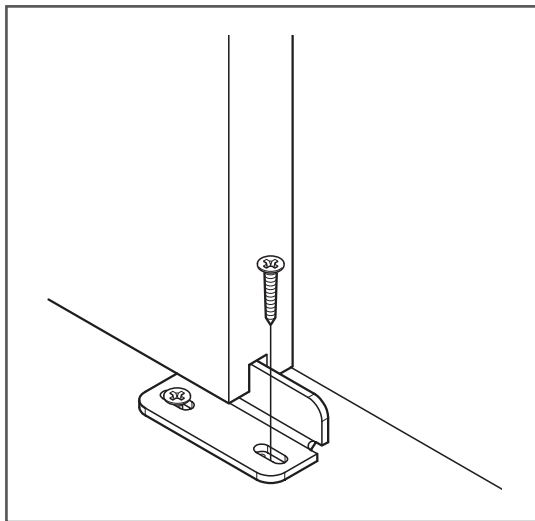

Figure 14

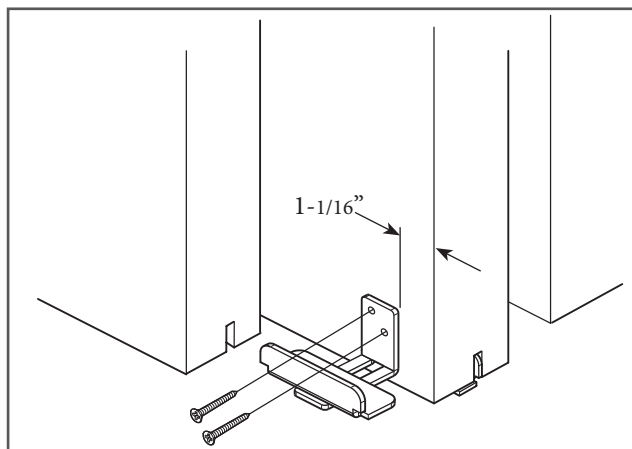

Figure 15

14. With the panel or door in the closed position, ensure the panel or door is hanging straight using a bubble level.

15. Position the door guide (H.) part way into the groove in the bottom of the panel or door (Figure 13).

SUGGESTION:

Use double stick tape on the bottom of the door guide to hold the guide in place.

16. Install the door guide using a 1" phillips screw (E.) and a drill with a phillips bit.

17. Slide the panel or door toward the open position until the other side of the Door Guide is exposed.

18. Install the second 1" phillips screw (E.) using a drill with a phillips bit (Figure 14).

COME -ALONG PANEL/DOOR GUIDE INSTALLATION

19. Slide both panels or doors toward the open position, sliding the front panel or door past the back for access to the back panel or door lower edge (Figure 15).

20. Mark a line 1-1/16" from the edge of the panel or door (Figure 15).

SUGGESTION:

Use double stick tape on the back of the Come-Along Door Guide to hold the guide in place.

21. Align the come-along (G.) edge to the pencil line and slightly above the panel or door's bottom edge to prevent scraping on the floor. Ensure that the groove from the front panel or door can pass over the come-along.

22. Install the come-along with two 1" phillips screws (E.) using a drill with a phillips bit (Figure 15).

PANEL/DOOR END PLATE INSTALLATION

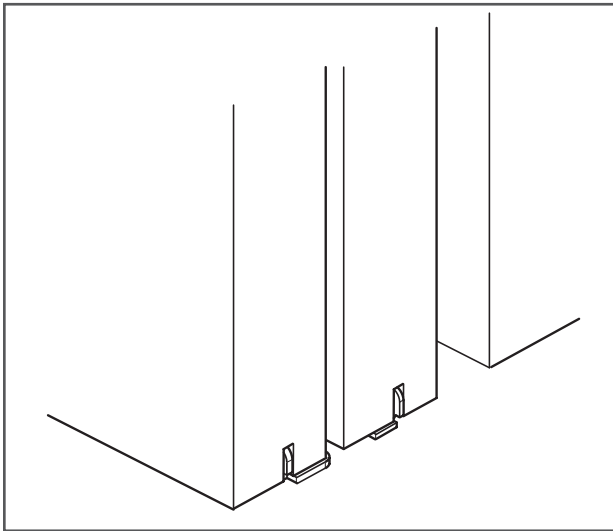

Figure 16

23. Position the doors over door guides as shown (Figure 16).

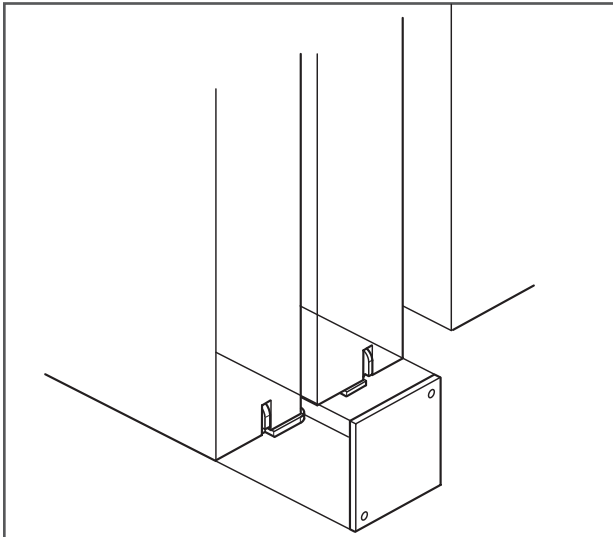

Figure 17

24. Position the end plate (H) on the bottom edge of the panel or door, aligning the plate with the side and bottom edges of the door (Figure 17).

SUGGESTION:
Use double stick tape on the back of the End Plate to hold the plate in place.

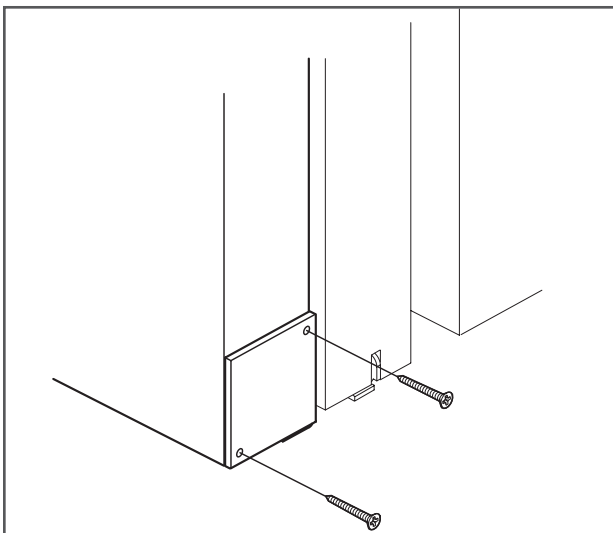

Figure 18

25. Install plate with two flat head Phillips screws (provided) and a drill with a Phillips bit (Figure 18).

26. Repeat steps 23 through 25 for the other end of the panel or door.

WE LOVE WHAT YOU ARE DOING WITH THE PLACE

**CONGRATULATIONS ON YOUR DECISION TO BRING HOME
AN AMERICAN MADE PRODUCT OF THE HIGHEST QUALITY.
WE HOPE YOUR TRIPLE BYPASS TRACK SYSTEM BRINGS ART AND
FUNCTION INTO YOUR LIFE.**

**DESIGNED AND CRAFTED
ENTIRELY IN THE**

U.S.A.



**DON'T BE A STRANGER. FOLLOW US
ON SOCIAL MEDIA.**



support@rusticahardware.com