



STABLE BARN DOOR

ASSEMBLY INSTRUCTIONS



RUSTICA

STABLE DOOR RECOMMENDED TOOLS

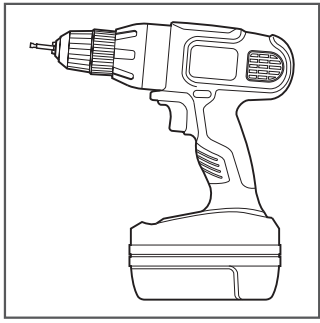

Drill with #2 Phillips Bit

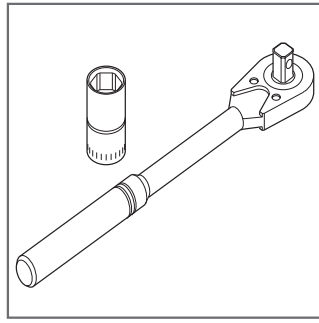

Socket Wrench
with 7/16" Socket

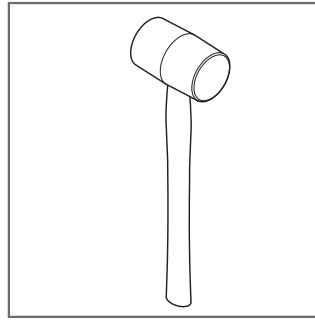

Rubber Mallet

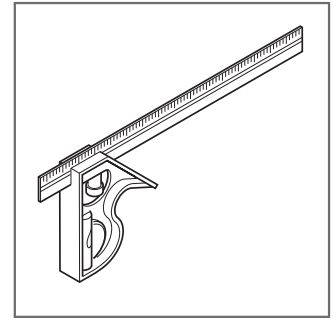

Adjustable Square

STABLE DOOR Parts

A1–Stile–Qty. 2

A2–Bottom Rail–Qty. 1

A3–Center Rail–Qty. 1

A4–Top Rail–Qty. 1

B1–Bottom TNG Left–Qty. 1

B2–Bottom TNG–*

B3–Bottom TNG Right–Qty. 1

C1–Top TNG Left–Qty. 1

C2–Top TNG–*

C3–Top TNG Right–Qty. 1

D1–Top Overlay–Qty. 2

D2–Bottom Overlay–Qty. 2

Lag Screws–Qty. 8

Grabber Screws–*

*Quantities will vary depending on door size.

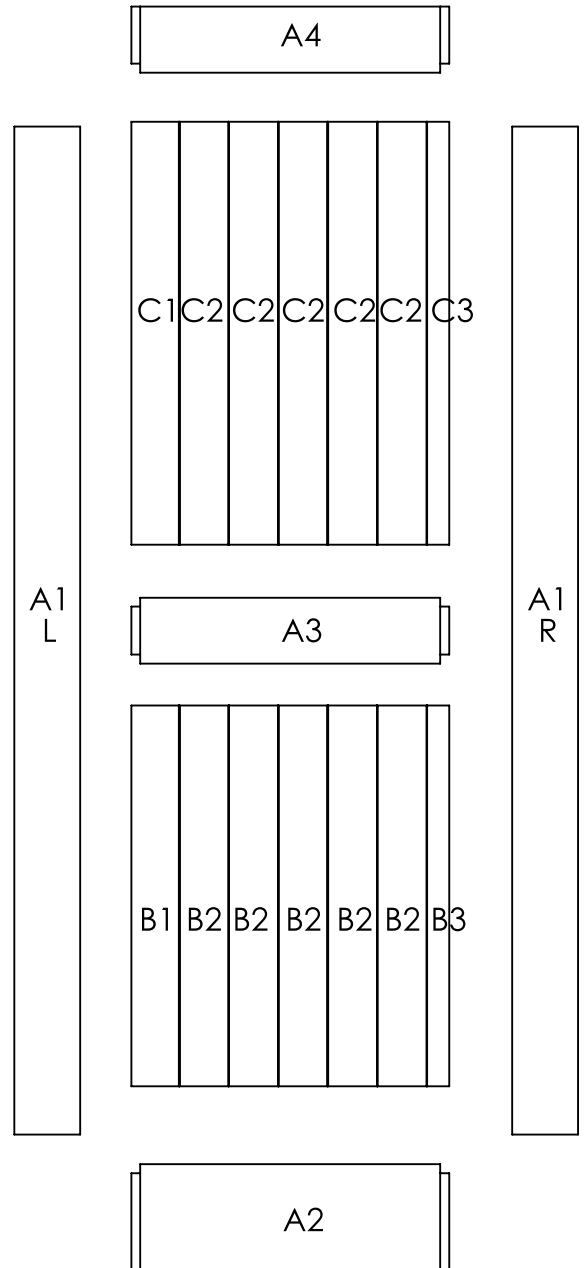
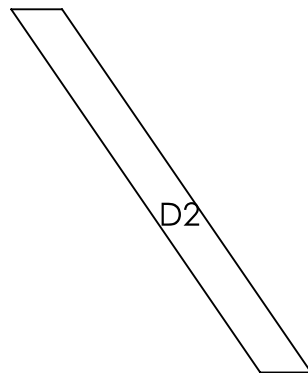
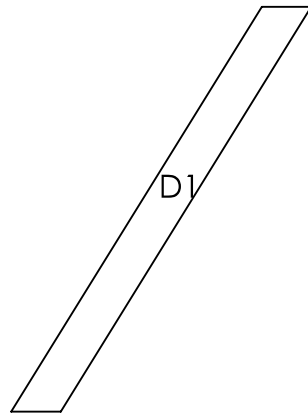

STABLE DOOR RECOMMENDED TOOLS

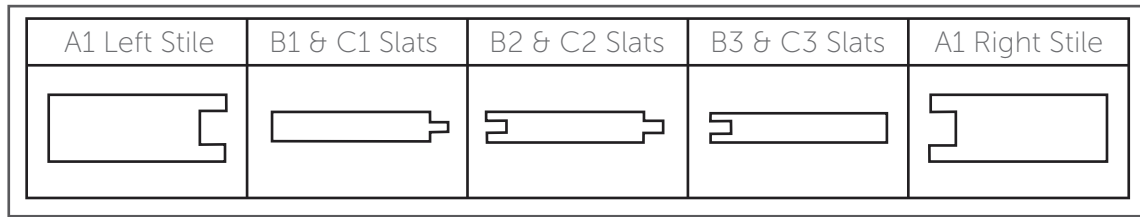

Slats & Stiles (End View)

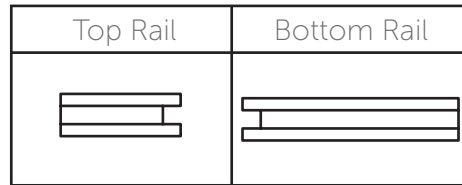

Rails (End View)

Lay out all wood parts before beginning assembly to ensure parts have not been damaged in shipping. If damage has occurred, call 800-891-8312 and Rustica Hardware will expedite a replacement.

NOTE: This door model comes in various sizes. The instructions have been written for the average single door size; but larger doors may have more wood and fastener parts.

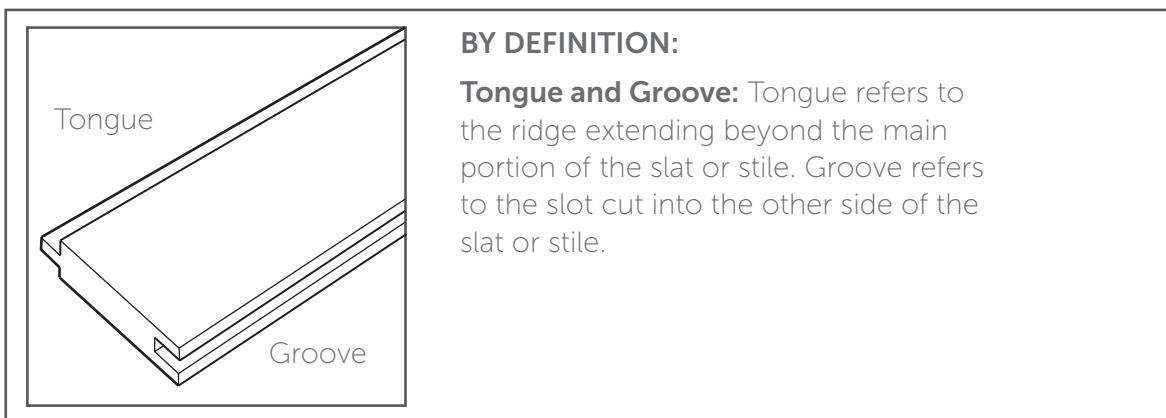
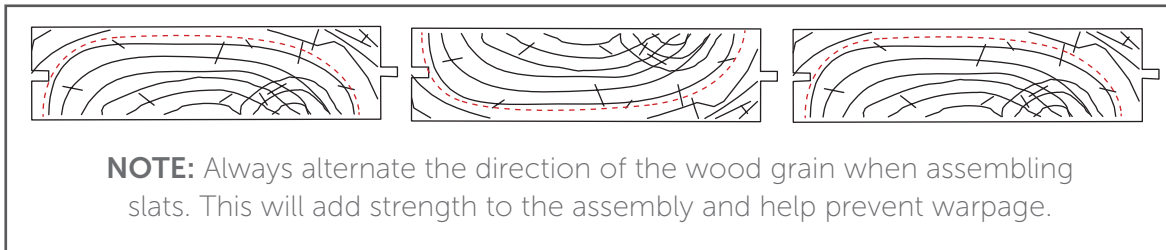

NOTE: The following is a "dry" assembly. Do not use adhesives when putting this door together.

**DIT! (DO IT TOGETHER)
WE RECOMMEND TWO
PEOPLE FOR THIS BUILD**



STABLE DOOR SPECIFICATIONS

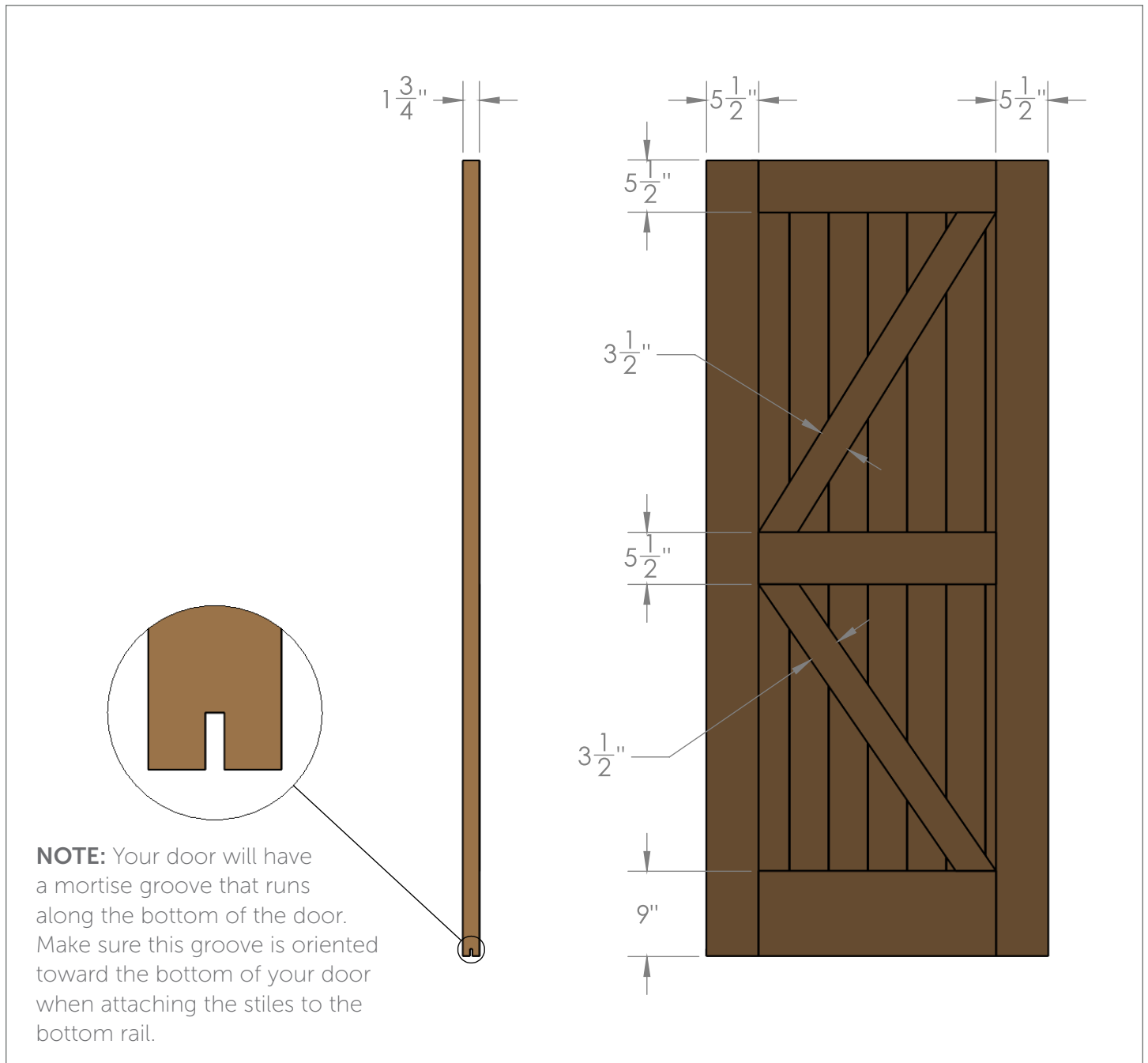

STABLE DOOR ASSEMBLY INSTRUCTIONS

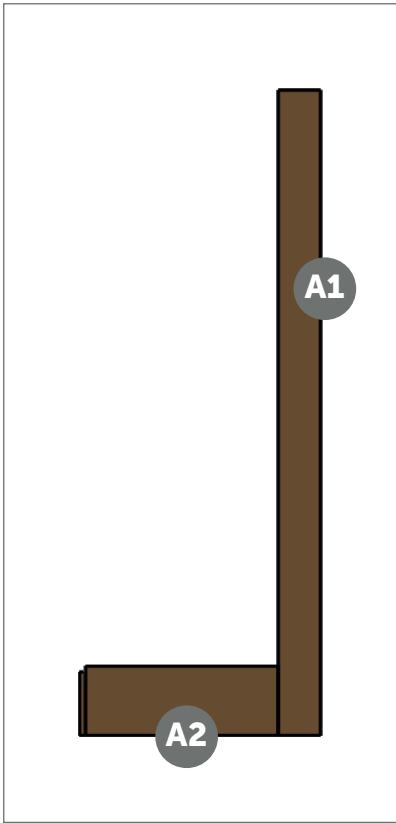

Step 1—Fasten A1 to A2 using socket to fasten lag screws, through the stile, ensuring the doors stays square.

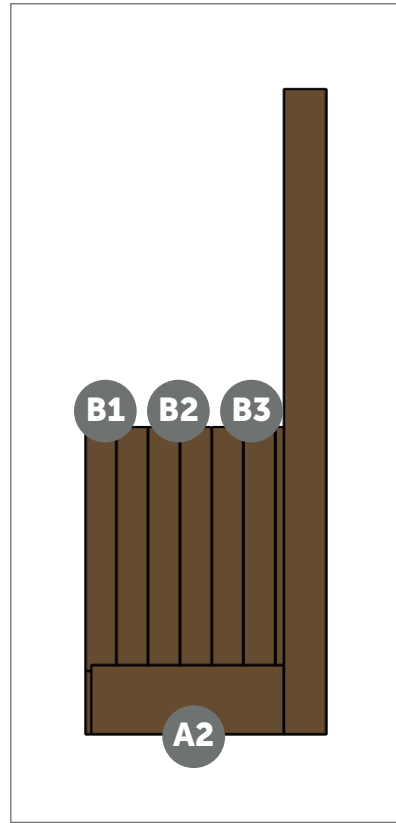

Step 2—Slide B3, B2, and B1 into groove of A2.

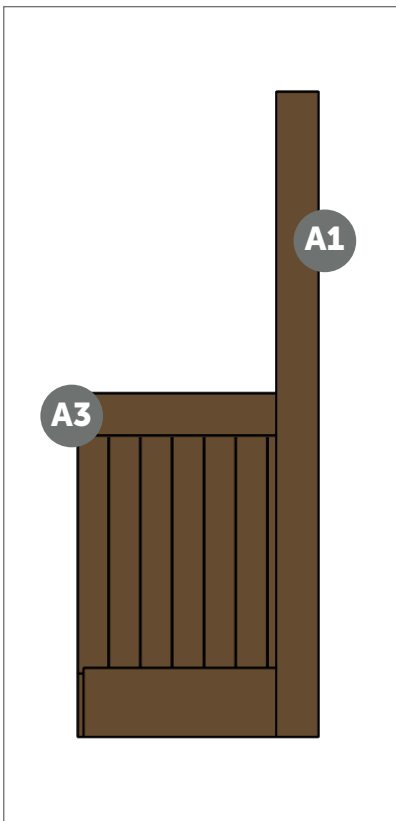

Step 3—Once bottom TNG has been positioned, place A3 into A1 with the TNG in the groove.

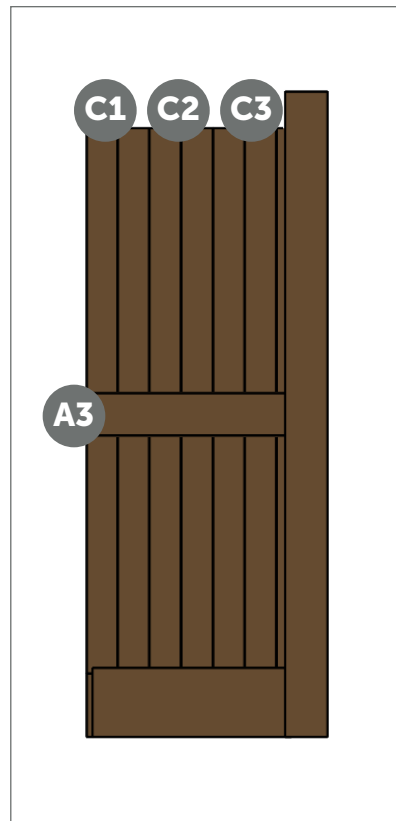

Step 4—Slide Top TNG (C1, C2, and C3), into the top groove of A3.



STABLE DOOR ASSEMBLY INSTRUCTIONS

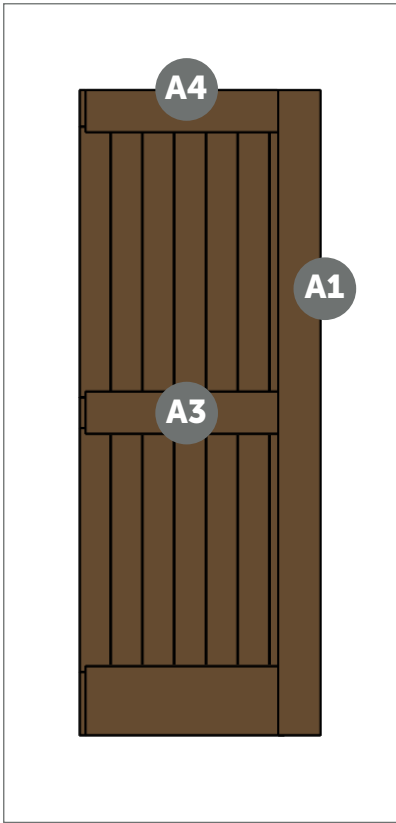

Step 5—Once the top TNG has been positioned, place A4 into A1 with the TNG in the groove.

Making sure the door is square, secure rails A3 and A4 to stile A1, using the provided lag screws.

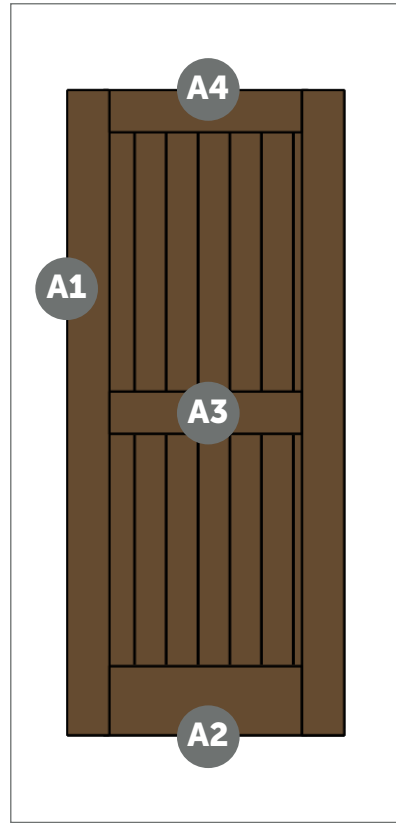

Step 6—With your rails held in square, attach the second stile A1 to door rails A2–A4.

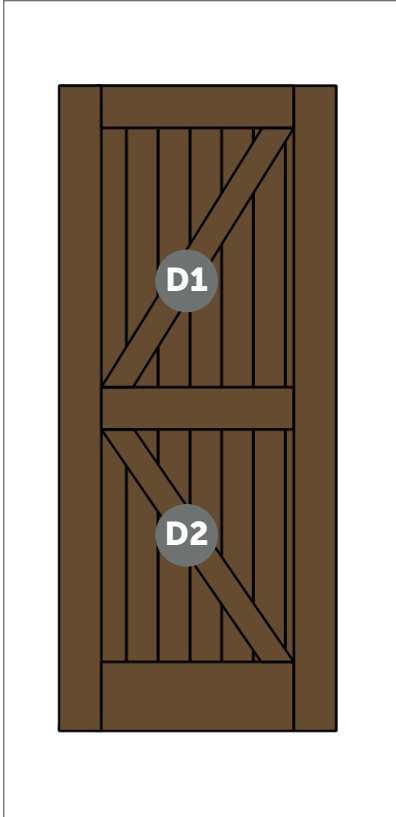

Step 7—With the door assembled, place overlays D1 and D2 on the door and secure to the TNG using finish nails or the provided grabber screws.



Step 8—Attach your hardware and your door is ready to use.



WE LOVE WHAT YOU'RE DOING WITH THE PLACE

CONGRATULATIONS ON YOUR DECISION TO BRING HOME
AN AMERICAN MADE PRODUCT OF THE HIGHEST QUALITY.
WE HOPE YOUR STABLE DOOR BRINGS ART AND FUNCTION INTO YOUR LIFE.

DESIGNED AND CRAFTED ENTIRELY IN THE
U.S.A.



DON'T BE A STRANGER.
FOLLOW US ON SOCIAL MEDIA.



support@rusticahardware.com