



LOW CLEARANCE BYPASS SYSTEM

ASSEMBLY INSTRUCTIONS



RUSTICA

LOW CLEARANCE BYPASS SYSTEM RECOMMENDED TOOLS

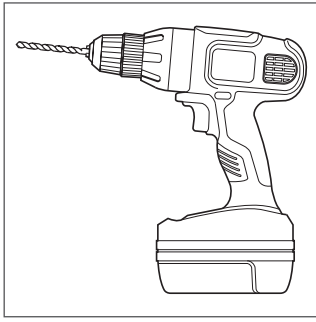

Drill with 1/8", 1/4" and 3/8" Bits,
1-1/8" Forstner bit, and Phillips Bit

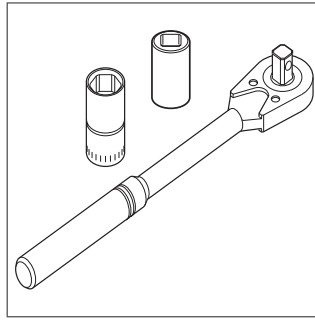

Socket Wrench
with 9/16" Socket

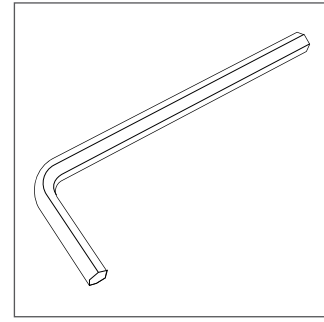

7/32" Allen Wrench

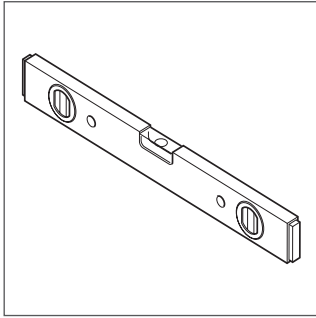

Level

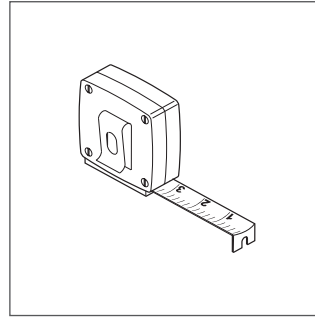

Tape Measure

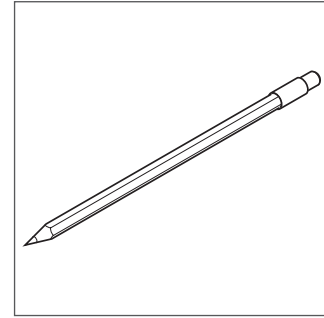

Pencil

LOW CLEARANCE BYPASS SYSTEM SPECIFICATIONS

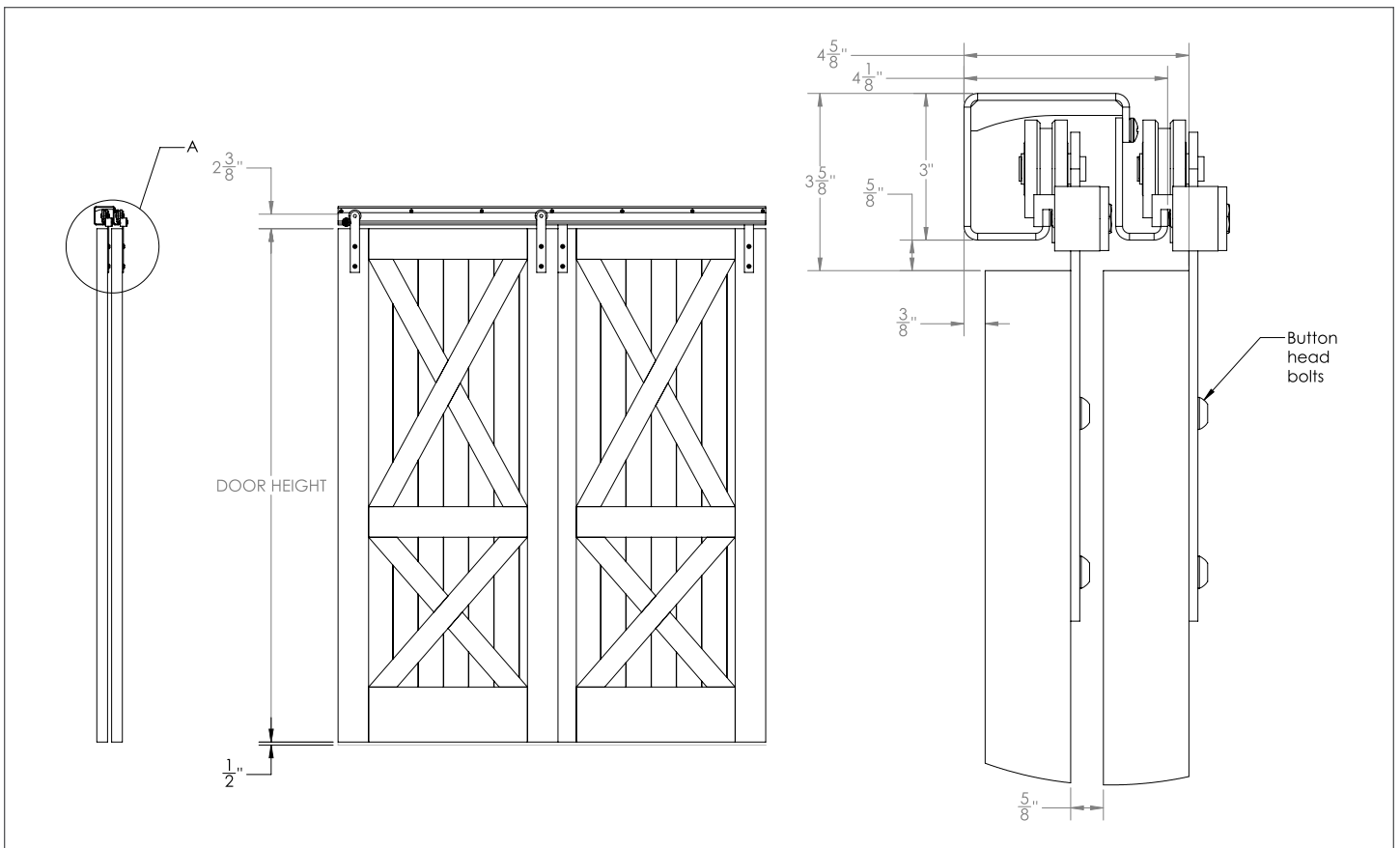

LOW CLEARANCE BYPASS SYSTEM PARTS

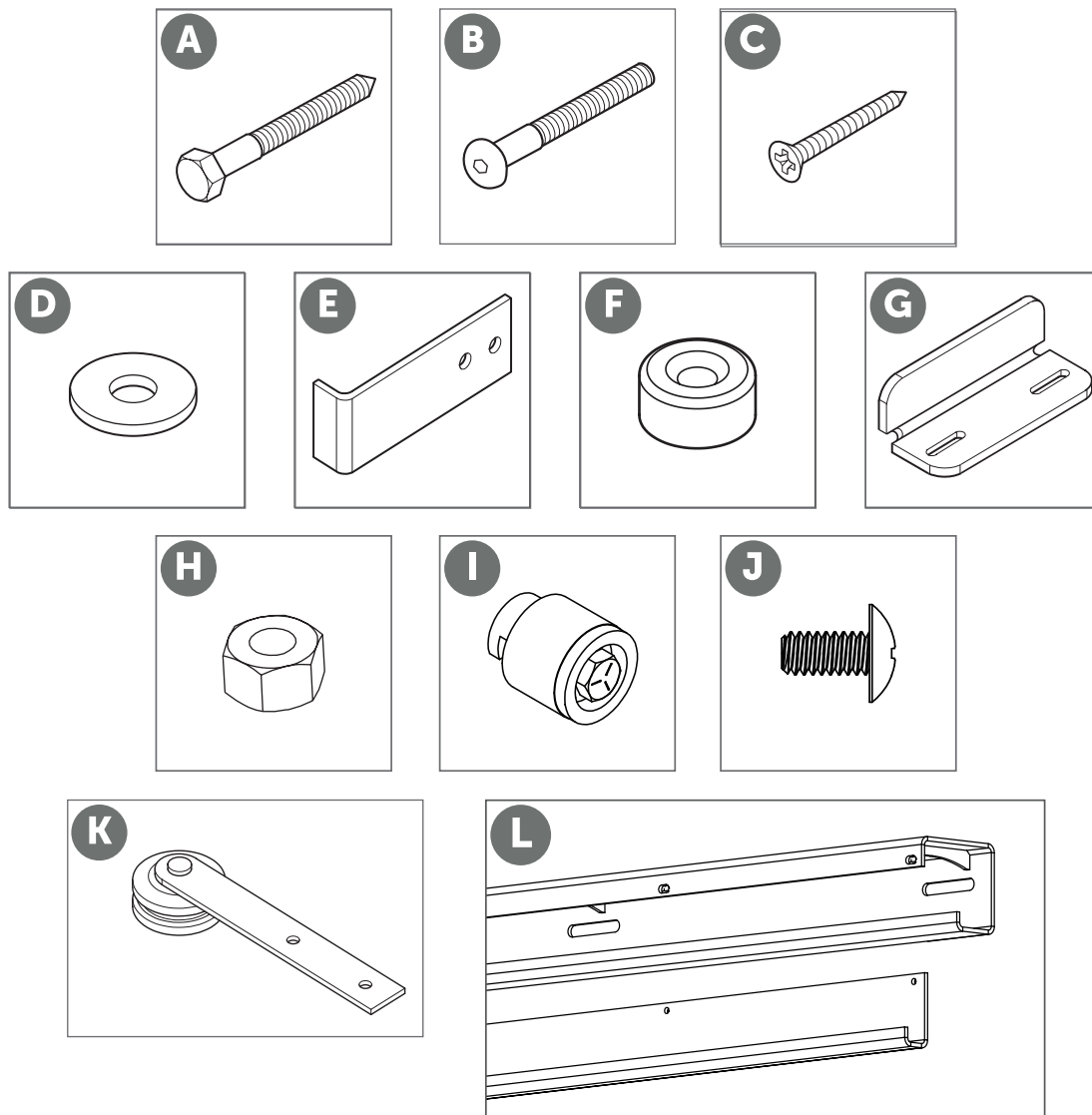

A Lag Screws

B Button Head Bolt

C Phillips Screw

D 1" Washer

E Anti-jump Bracket

F Anti-jump Block (For use on bi-parting door systems)

G Door Guide

H Hex Nut

I Round Adjustable Stop

J 1/4-20 Machine Screws

K Hanger Assembly

L Low Clearance Tracks (Back and Front)

DIT! (DO IT TOGETHER)
WE RECOMMEND TWO
PEOPLE FOR THIS BUILD



LOW CLEARANCE BYPASS SYSTEM ASSEMBLY INSTRUCTIONS

NOTE: Doors using Floor Mount Door Guides will have a groove on the bottom. Ensure this groove is on the opposite end of the Door Hanger Installation.

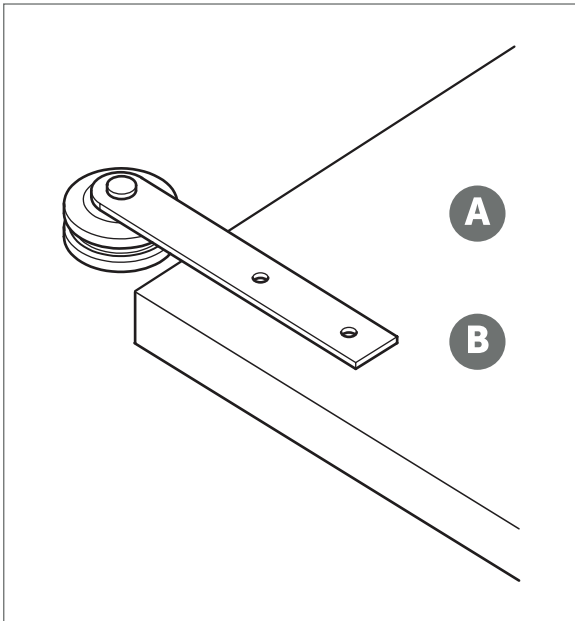
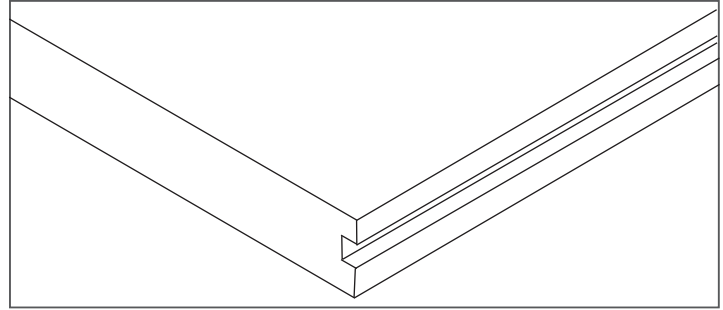

- A** Lay the door with the front facing up on a flat, level surface.
- B** Place the hanger on the door.

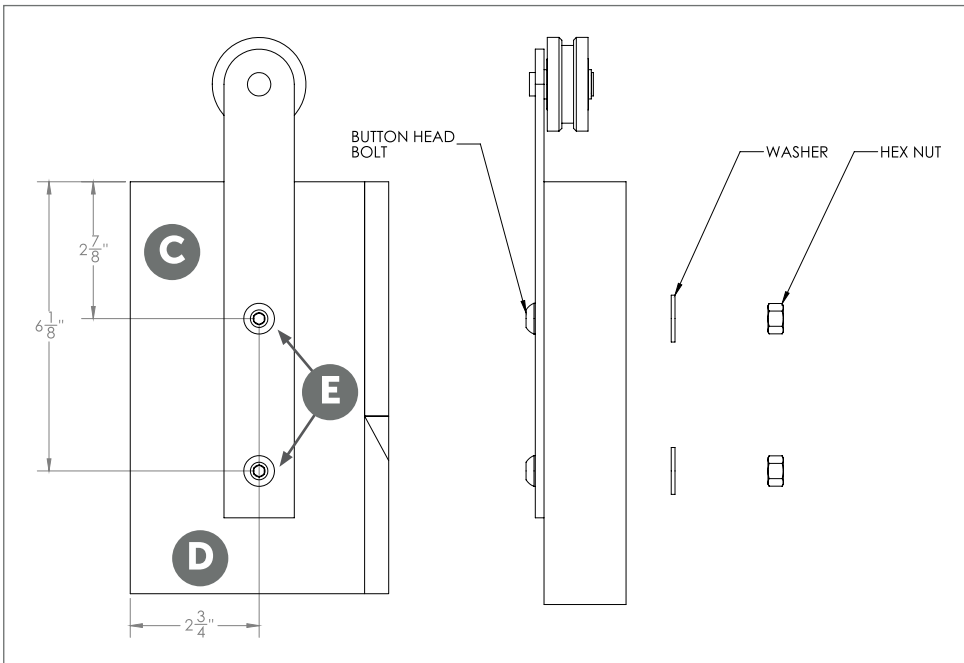

C Adjust the placement of the hanger for a 2-7/8" gap between the top of the door and the top hole in the hanger.

D The side of the hanger should rest 2-3/4" from the edge of the door.

E Mark the center of each installation hole with a pencil.

Repeat steps 2-4 for the opposite end of the door. Set the hangers aside.



LOW CLEARANCE BYPASS SYSTEM ASSEMBLY INSTRUCTIONS

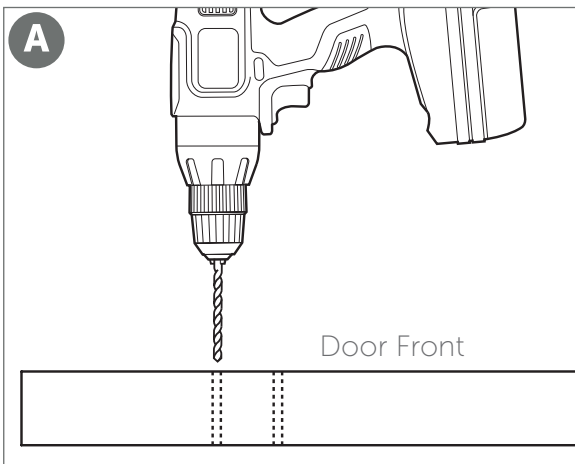

A Drill two pilot holes all the way through the door for each hanger using a drill with an 1/8" drill bit for each hanger using a drill with an 1/8" drill bit.

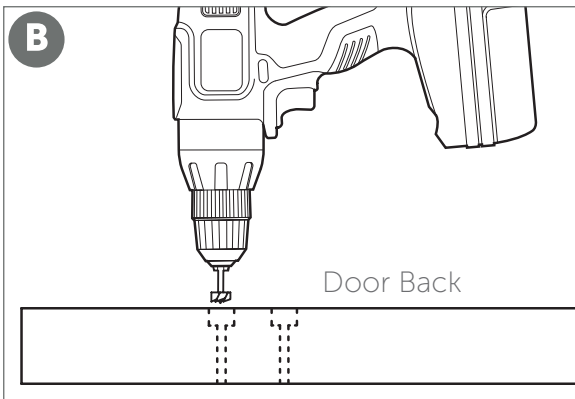

B Turn the door over. Using a 1-1/8" Forstner bit*, drill a 7/16" deep hole into each pilot hole.

*A 1-1/8" Spade bit may be used in place of a Forstner bit.

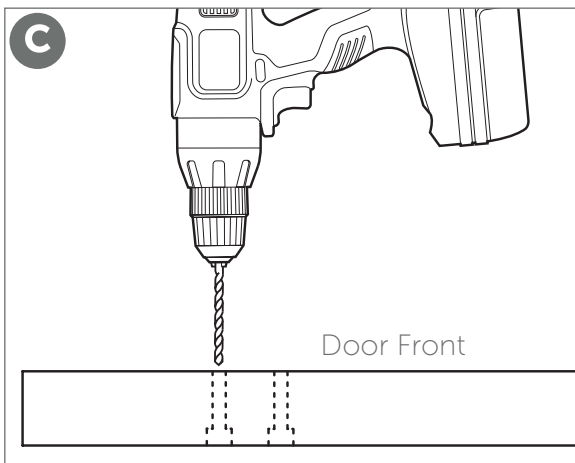

C Turn the door over, returning it to the face-up position. Drill all the way through the pilot holes using a drill with a 3/8" drill bit.

D Install the hangers to the front of the door using button head bolts, washers, and hex nuts (provided), using a 7/32" Allen wrench and 9/16" socket.

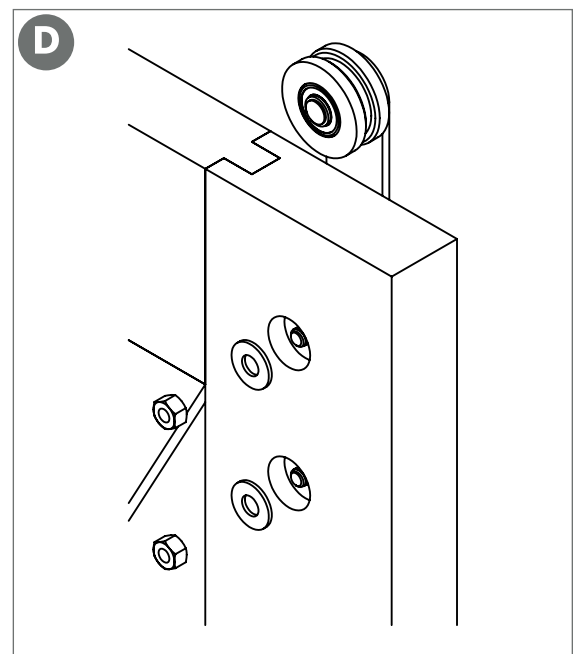

LOW CLEARANCE BYPASS SYSTEM ASSEMBLY INSTRUCTIONS

FIRST THINGS FIRST

Check to see if the floor below the track is level. If the floor rises more than 1/2", the door may rub or not slide open completely. If the floor is not level, measure from the highest point of the floor surface to the recommended track placement and adjust track placement accordingly.

Ensure the track will be installed onto wall studs. If wall studs are not lining up with the installation a header will be required to provide the necessary strength and stability for the track and door.

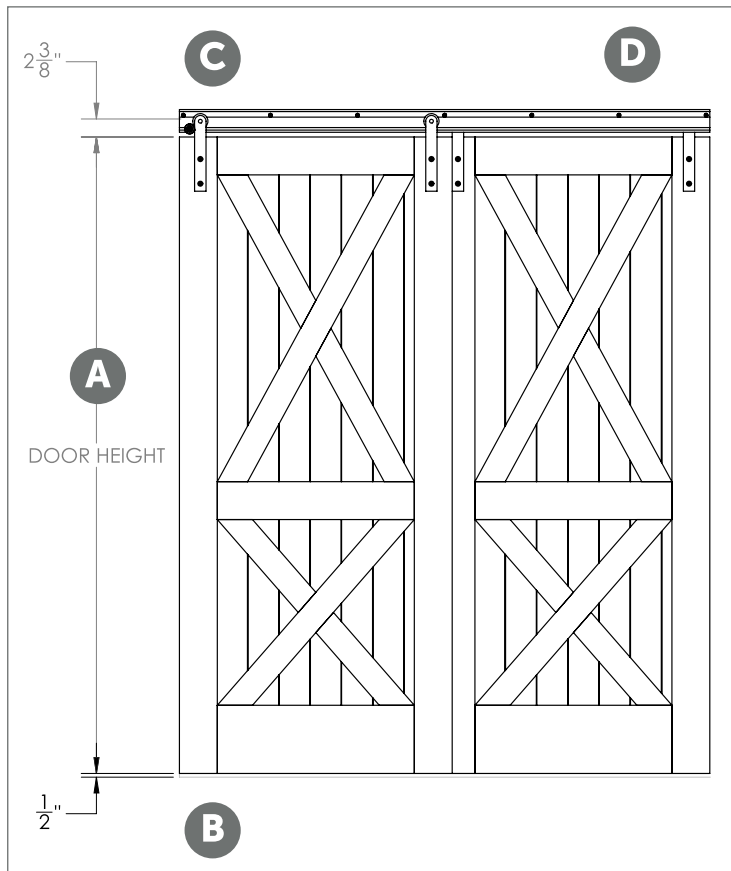

TRACK & DOOR INSTALLATION

- A** To determine where the track should be installed, first measure the height of the door, then add 2-7/8" to the door length. **B** 1/2" will be for the clearance between the bottom edge of the door and the floor. **C** 2-3/8" will be from the top edge of the door to the center of the hole.
- D** Using a level and a pencil, mark a line above the doorway the same length as the track.

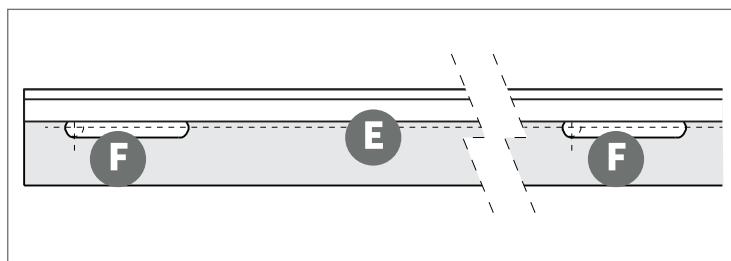

- E** Hold the track up to where the pencil line is visible through the holes in the track.

SUGGESTION: Use pieces of double stick tape on the back of the track to help hold the track in place while completing steps **D** and **E**.

- F** Mark an intersecting line inside each slotted hole wherever they work best for your wall (i.e. stud locations).

Take the track down, remove double stick tape (if used) and set the track aside.



LOW CLEARANCE BYPASS SYSTEM ASSEMBLY INSTRUCTIONS

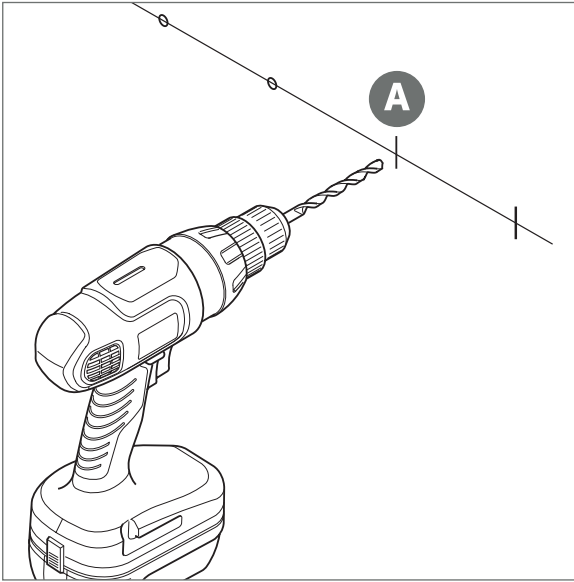

A Drill out the marked holes using a drill with a 1/4" drill bit.

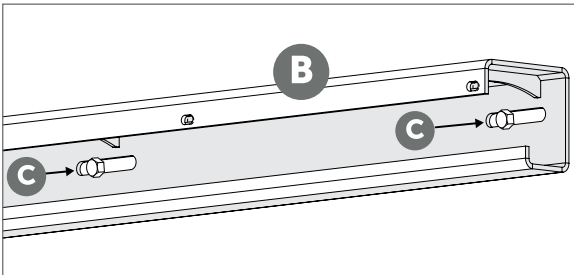

B Mount back track to the wall and **C** secure with 3/8" lag screws.

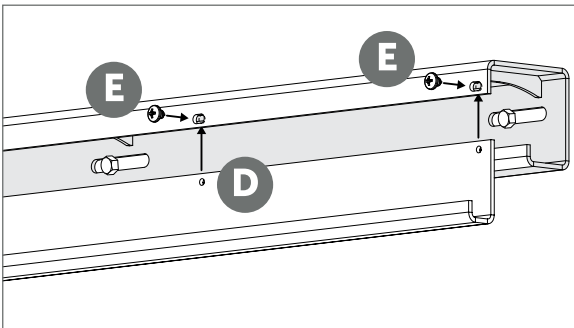

D Slide front track behind overhang of back track and **E** secure using 1/4-20 machine screws into threaded holes.



LOW CLEARANCE BYPASS SYSTEM ASSEMBLY INSTRUCTIONS

DOOR GUIDE INSTALLATION

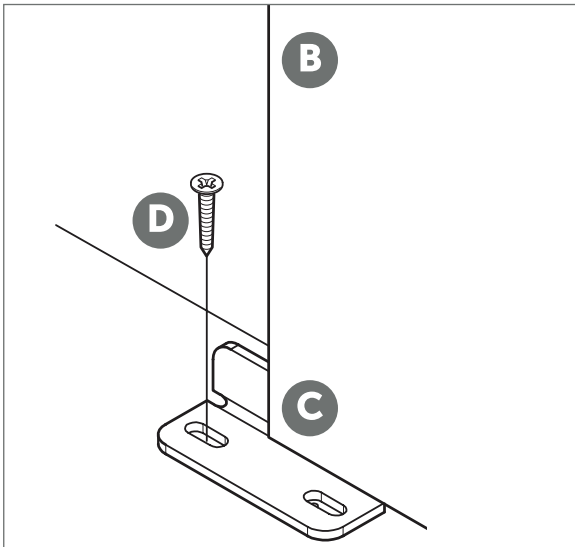

B With the door in the closed position, ensure the door is hanging straight using a bubble level.

C Position the Door Guide part way into the groove in the bottom of the door.

SUGGESTION: Use double stick tape on the bottom of the door guide to hold the guide in place.

D Install the Door Guide using a Phillips screw (provided) and a drill with a phillips bit.

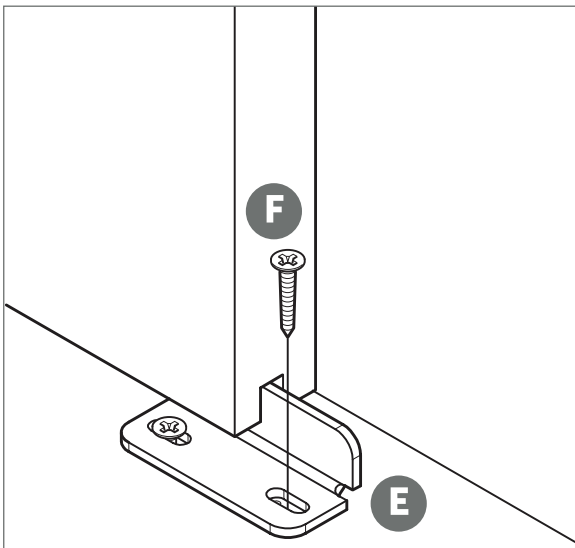

E Slide the door toward the open position until the other side of the Door Guide is exposed.

F Install the second Phillips screw (provided) using a drill with a phillips bit.

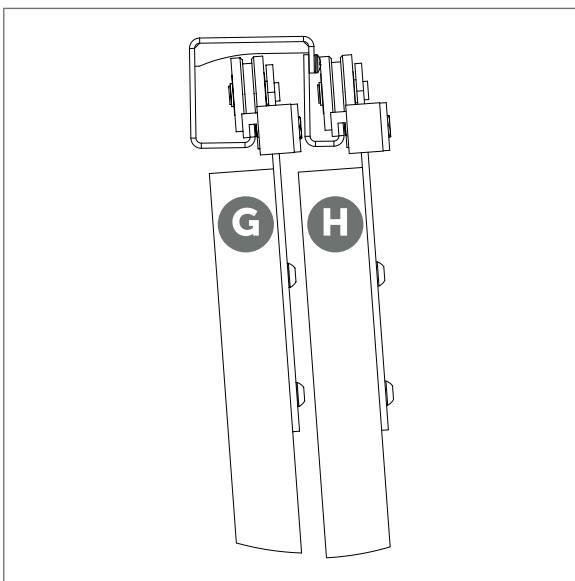

G Hang the back door first then **H** hang the front door.



LOW CLEARANCE BYPASS SYSTEM ASSEMBLY INSTRUCTIONS

ADJUSTABLE STOP INSTALLATION

- A** Place the adjustable stop on your track.
- B** Position along the length of your track to stop door at the desired location. Tighten bolt with a 9/16" wrench/socket.

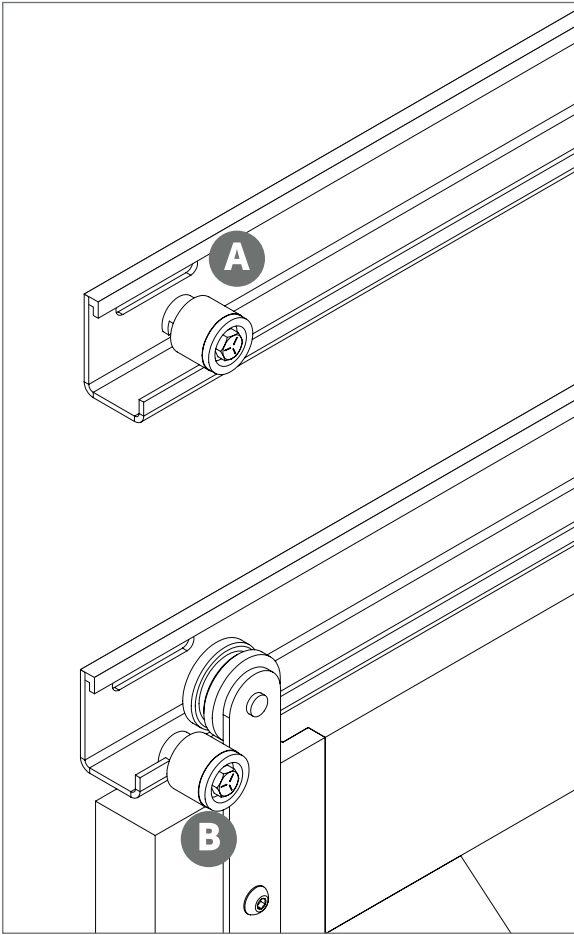

WE LOVE WHAT YOU'RE DOING WITH THE PLACE

CONGRATULATIONS ON YOUR DECISION TO BRING HOME
AN AMERICAN MADE PRODUCT OF THE HIGHEST QUALITY.
WE HOPE YOUR LOW CLEARANCE BYPASS SYSTEM
BRINGS ART AND FUNCTION INTO YOUR LIFE.

DESIGNED AND CRAFTED ENTIRELY IN THE
U.S.A.



DON'T BE A STRANGER.
FOLLOW US ON SOCIAL MEDIA.



support@rustica.com