

# RUSTICA

## INSTALLATION INSTRUCTIONS

### SEA JEANS

### FACE MOUNT HANGER ON FLAT TRACK

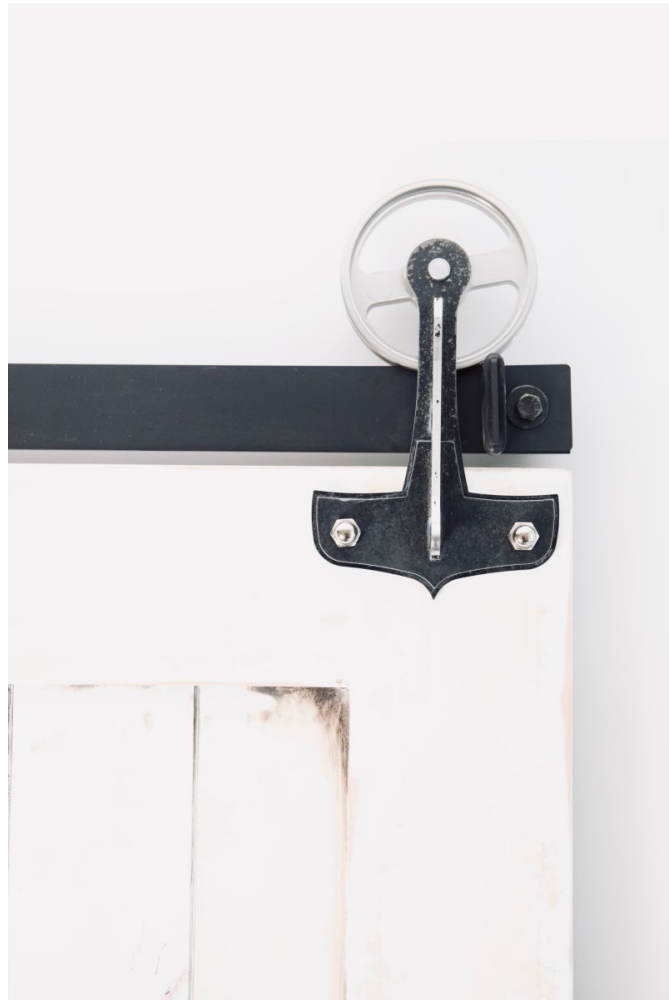

CONGRATULATIONS ON YOUR DECISION TO BRING HOME  
AN AMERICAN MADE PRODUCT OF THE HIGHEST QUALITY

1-800-891-8312  
support@rustica.com  
www.Rustica.com

DESIGNED AND CRAFTED ENTIRELY IN THE

# U.S.A.



DON'T BE A STRANGER  
FOLLOW US ON SOCIA MEDIA.



# HANGER Parts and Recommended Tools

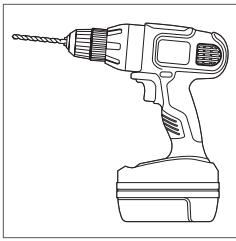

Drill with 1/8", 1/4", and 3/8" Drill Bits, 1-1/8" Forstner Bit or 1-1/8" Spade Bit and Phillips Bit

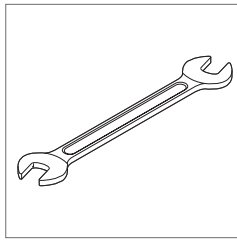

9/16" and 5/8" Combination Wrench

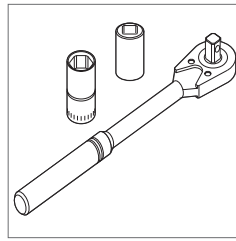

Socket Wrench with 9/16" and 5/8" Sockets

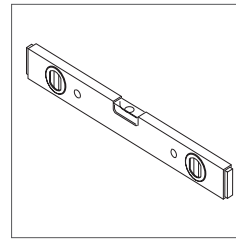

Level

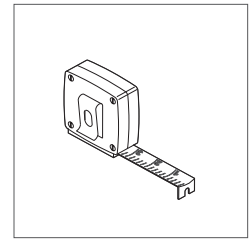

Tape Measure

## NOTE:

The following instructions are for flat track systems only.  
Do not attempt to use on tube, bypass J-track or ceiling mount track systems.

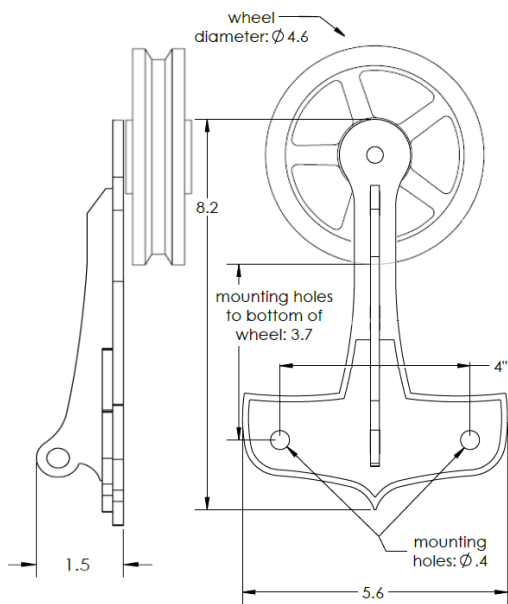

## PARTS

- A. Hanger Assembly (typically 2)
- B. Lag Screws (typically the same amount as the number of holes in the track)
- C. Hex Bolts (2 per hanger)
- D. Phillips Screws (2 per guide & 2 per Anti-Jump Bracket or 1 per Anti-Jump Block)
- E. 1" Washer (1 per track hole and 2 per Hex Bolt kit)
- F. Anti-Jump Bracket (2) or
- G. Anti-Jump Blocks (4, only for bi parting doors)
- H. Door Guide (1)
- I. Adjustable Spacers (typically the same amount as the number of holes in the track.
- J. Acorn Nuts (2 per hanger)
- K. Standard Stop & Rubber Bumper (2 per standard
- L. system) Track

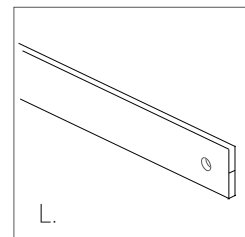
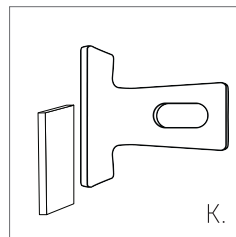
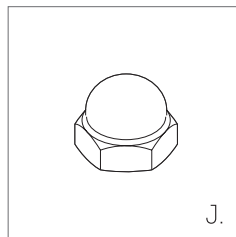
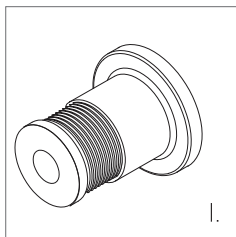
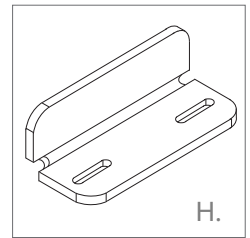
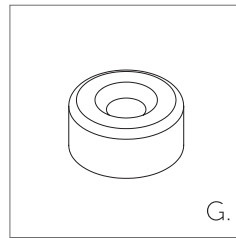
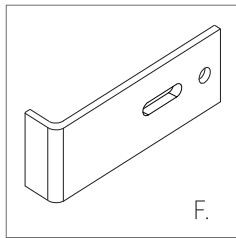
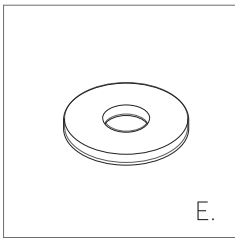
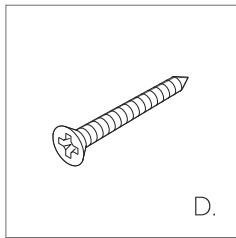
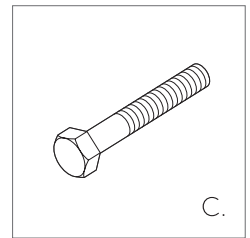
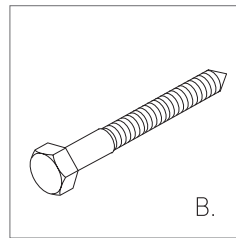
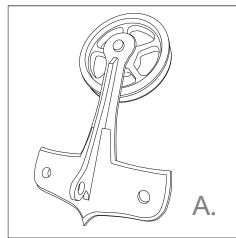

# HANGER Assembly Instructions

**NOTE:**  
Doors using a Floor Mount Door Guide will have a groove on the bottom. Ensure this groove is on the opposite end of the door hanger installation

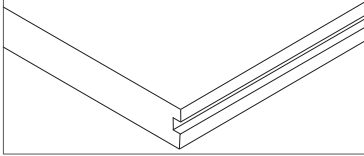

## HANGER INSTALLATION

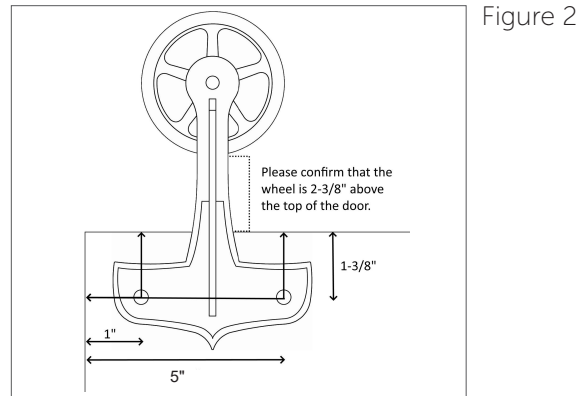
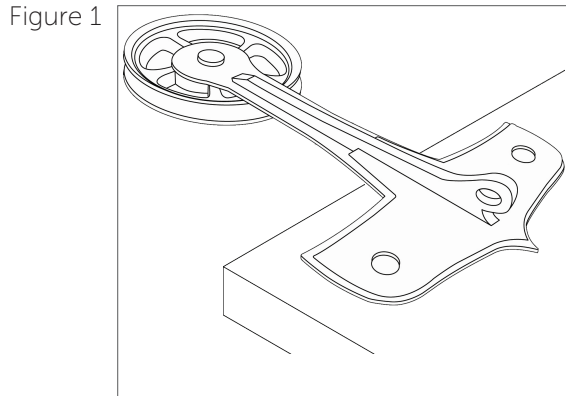

1. Lay the door with the front facing up on a flat level surface.
2. Place the hanger on the door (Figure 1).
3. Adjust the placement of the hanger for a 2-3/8" gap between the top of the door and the bottom of the wheel. Ensure the hanger is positioned so that the holes are 1" and 5-1/8" from the side of the door (Figure 2).
4. Mark the center of each installation hole with a pencil (Figure 2).
5. Repeat steps 2-4 for the opposite end of the door and set the hangers aside.
6. Drill two pilot holes all the way through the door for each hanger using a drill with an 1/8" drill bit (Figure 3).
7. Turn the door over and using a 1-1/8" Forstner bit\*, drill a 7/16" deep hole into each pilot hole (Figure 4).
8. Turn the door over, returning it to the face-up position. Drill all the way through the pilot holes using a drill with a 3/8" drill bit (Figure 5).
9. Install the hangers to the front of the door using the lag bolt, washers and acorn nuts provided (Figure 6).

\* A 1-1/8" spade bit may be used in place of a Forstner bit.

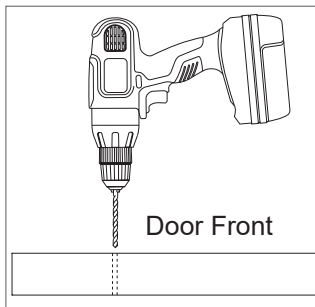

Figure 3

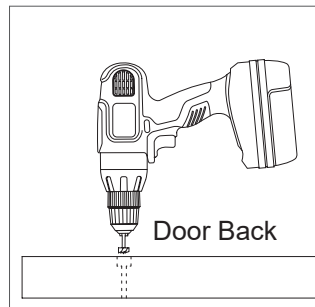

Figure 4

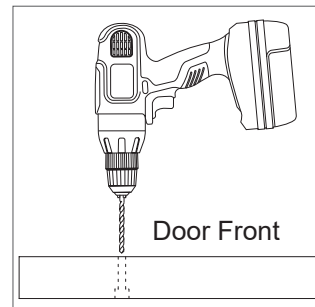

Figure 5

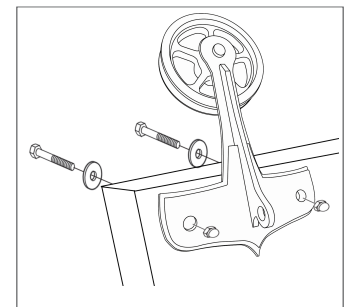

Figure 6



# FLAT TRACK Assembly Instructions

**Use teamwork. We recommend two people for this build.**

## FIRST THINGS FIRST

Check to see if the floor below the track area is level. If the floor is not level and rises more than 1/2" the door may rub or not slide properly. If the floor is not level, measure from the highest point of the floor surface to the recommended track placement and adjust track placement accordingly. Ensure the track will be installed into wall studs, wood backing in the wall or a header board that is installed into wall studs.

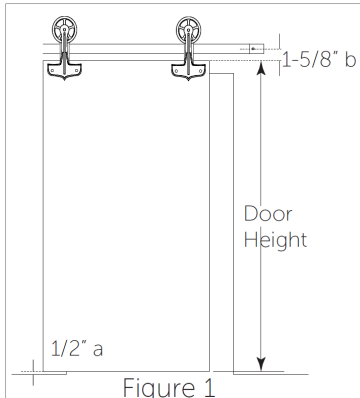

Figure 1

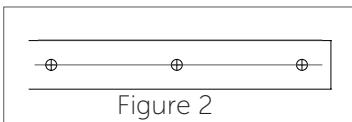

Figure 2

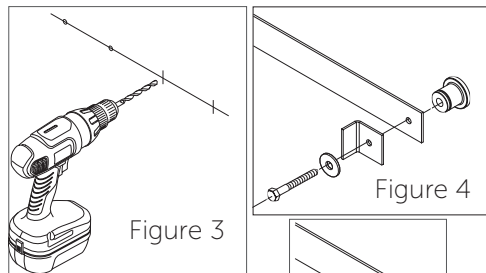

Figure 3

Figure 4

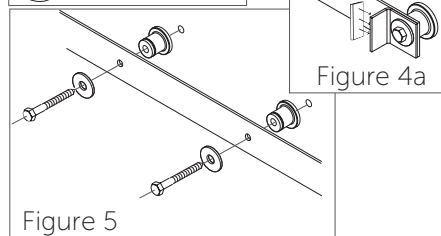

Figure 5

Figure 4a

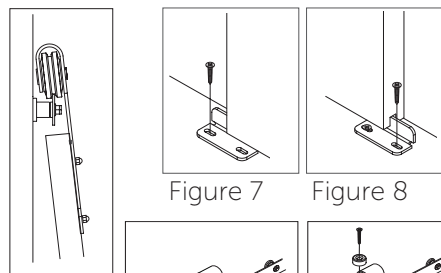

Figure 6

Figure 7

Figure 8

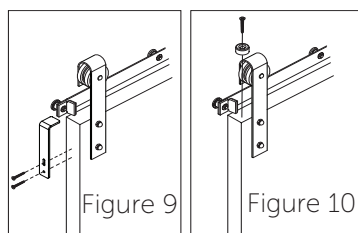

Figure 9

Figure 10

## TRACK INSTALLATION

1. To determine where the track should be installed, first measure the height of the door, then add 2-1/8" to the door height. 1/2" (a) will be for the clearance between the bottom edge of the door and the floor. 1-5/8" (b) will be from the top edge of the door to the center of the track. (Figure 1).
2. Using a level and a pencil, make a line on the wall at this height. It will be the centerline of the track.
3. Hold the track up to where the pencil line is visible through the holes in the track. Mark an intersecting line in the center of each hole (Figure 2).
4. Take the track down, drill out the marked holes using a drill with 1/4" drill bit (Figure 3).
5. Attach one end of the track to the wall with one standard stop, one lag screw, one spacer and one washer, using a socket wrench with 9/16" socket (Figure 4). Do not tighten.
6. Repeat step 5 for the other end of the track.
7. Attach the rubber bumper to the inside of the standard stop. Repeat for the hard stop on the other end of the track (Figure 4a).
8. Install remaining spacers with lag screws and washers using a 9/16" socket wrench (Figure 5). Tighten all lag screws.
9. Hang the door (Figure 6).

## DOOR GUIDE INSTALLATION

1. With the door in the closed position, ensure the door is hanging straight using a bubble level.
2. Position the Door Guide part way into the groove in the bottom of the door (Figure 7).
3. Install the Door Guide using a 1" Phillips screw (provided) and a drill with a Phillips bit.
4. Slide the door toward the open position until the other side of the Door Guide is exposed.
5. Install the second 1" Phillips screw (provided) using a drill with a Phillips bit (Figure 8).

## ANTI-JUMP GUIDE INSTALLATION

1. Place the Anti-Jump bracket on the door side, moving the bracket up until it is between 1/8" and 1/16" from the bottom edge of the rail. Mark the placement with a pencil. \*
2. Install the bracket to the door edge with 2 Phillips screws (provided) using a drill with a Phillips bit (Figure 9).
3. Repeat steps 1 and 2 for the opposite end of the door.  
OR
4. Place the Anti-Jump block on the top of the door (Figure 10). Using a drill with a Phillips bit, install the block with the 1" Phillips screw (provided).
5. Repeat step 4 for the opposite end of the door.

