

RUSTICA

INSTALLATION
INSTRUCTIONS

GRAPPLE

SINGLE TRACK
BYPASS SYSTEM



CONGRATULATIONS ON YOUR DECISION TO BRING HOME
AN AMERICAN MADE PRODUCT OF THE HIGHEST QUALITY

1-800-891-8312
support@rustica.com
www.Rustica.com

DESIGNED AND CRAFTED ENTIRELY IN THE

U.S.A.



DON'T BE A STRANGER
FOLLOW US ON SOCIAL MEDIA



HANGER Parts and Recommended Tools

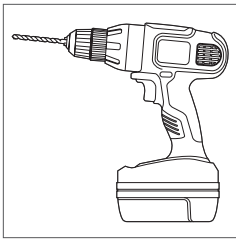

Drill with 1/8", 1/4", and 3/8"
Drill Bits, 1-1/8" Forstner Bit or
1-1/8" Spade Bit and Phillips Bit

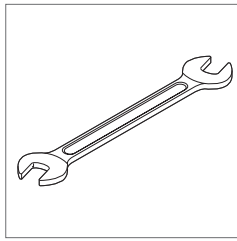

9/16" and 5/8"
Combination Wrench

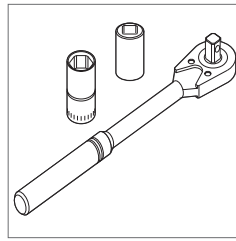

Socket Wrench with
9/16" and 5/8" Sockets

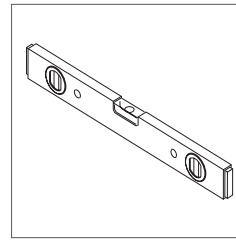

Level

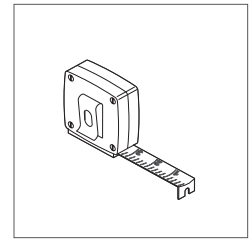

Tape Measure

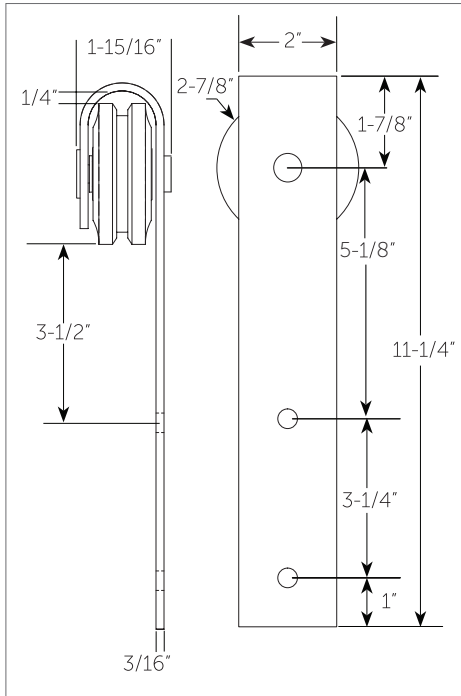

NOTE:

The following instructions are for flat track systems only. Do not attempt to use on tube, bypass, J-track, or ceiling mount track systems.

PARTS

- A. Hanger Assembly (2 and 2)
- B. Lag Screws (typically the same amount as the number of holes in the track)
- C. Hex Bolts (2 per hanger)
- D. Phillips Screws (2 per guide & 2 per Anti-Jump Bracket or 1 per Anti-Jump Block)
- E. 1" Washer (1 per track hole and 2 per Hex Boltkit)
- F. Anti-Jump Bracket (2 for the door closest to the wall, the other door's anti-jumps are integrated into the hanger)
- G. Door Guides (2 - one will be mounted to the door closest to the wall and the other can be a floor or wall mounted guide)
- H. Adjustable Spacers (typically the same amount as the number of holes in the track).
- I. Acorn Nuts (2 per hanger)
- J. Bumper (2 per standard system)
- K. Track

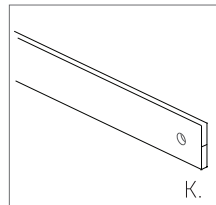
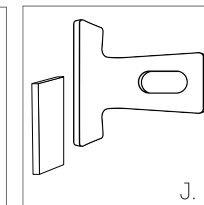
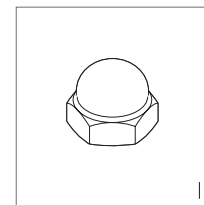
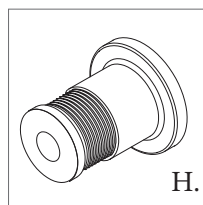
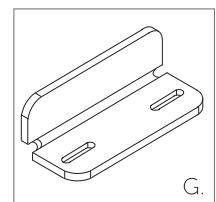
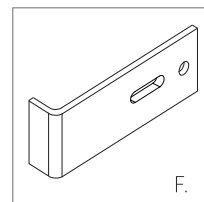
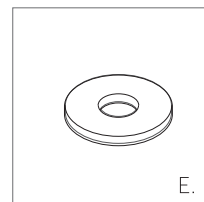
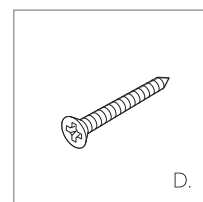
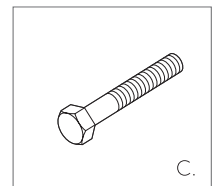
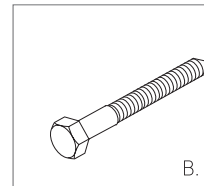
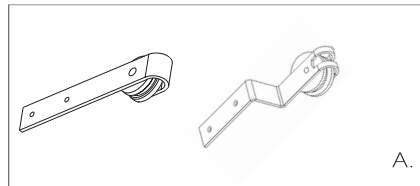
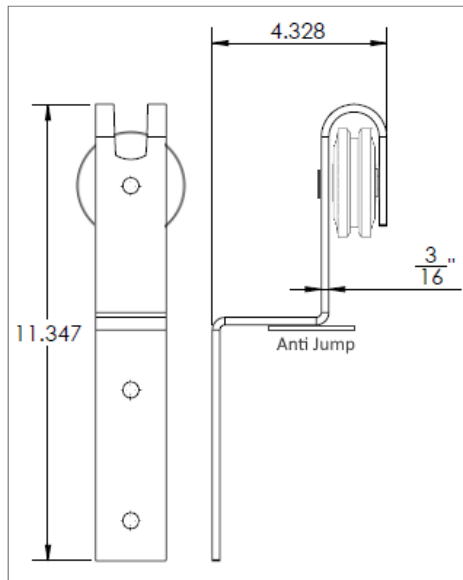

HANGER Assembly Instructions

NOTE:
Doors using a Floor Mount Door Guide will have a groove on the bottom. Ensure this groove is on the opposite end of the door hanger installation

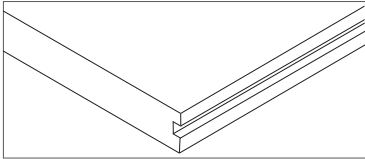

HANGER INSTALLATION

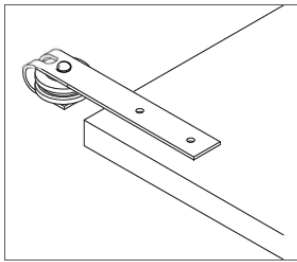

Figure 1

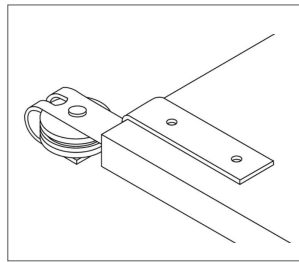

Figure 2

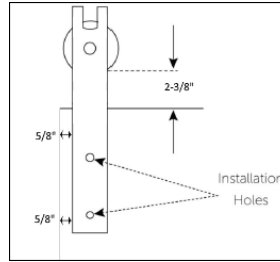

Figure 3

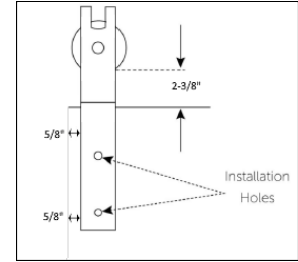

Figure 4

1. Lay the doors with the front facing up on a flat level surface.
2. Place a straight hanger on the door that will go closest to the wall (Figure 1) and a angled hanger on the door that will go furthest from the wall (Figure 2).
3. Adjust the placement of the hanger for a 2-3/8" gap between the top of the door and the bottom of the wheel. Ensure the side of the hanger at the top of the door is resting 5/8" from the edge of the door so that the edge of the wheel lines up with the edge of the door (Figure 3 & 4).
4. Mark the center of each installation hole with a pencil (Figure 3 & 4).
5. Repeat steps 2-4 for the opposite end of the door and set the hangers aside.
6. Drill two pilot holes all the way through the door for each hanger using a drill with an 1/8" drill bit (Figure 5).
7. Turn the door over and using a 1-1/8" Forstner bit*, drill a 7/16" deep hole into each pilot hole (Figure 6).
8. Turn the door over, returning it to the face-up position. Drill all the way through the pilot holes using a drill with a 3/8" drill bit (Figure 7).
9. Install the hangers to the front of the door using the lag bolt, washers and acorn nuts provided (Figure 8).

* A 1-1/8" spade bit may be used in place of a Forstner bit.

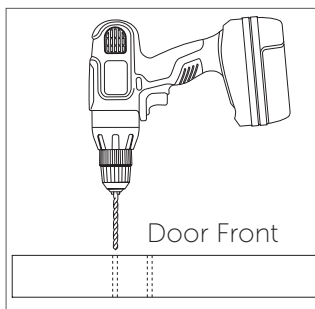

Figure 5

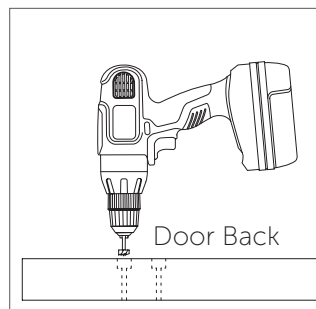

Figure 6

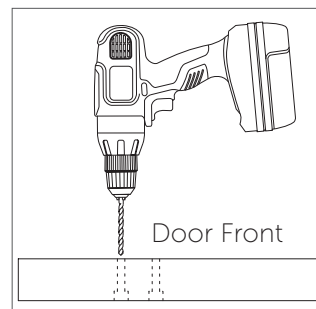

Figure 7

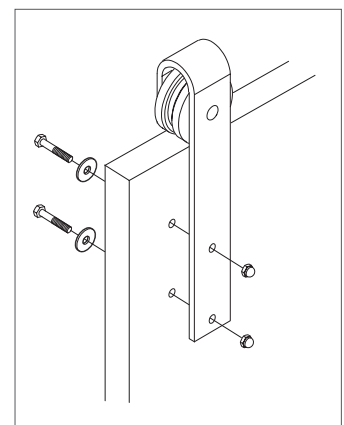

Figure 8



FLAT TRACK Assembly Instructions

Use teamwork. We recommend two people for this build.^{FIRST} THINGS FIRST

Check to see if the floor below the track area is level. If the floor is not level and rises more than 1/2" the door may rub or not slide properly. If the floor is not level, measure from the highest point of the floor surface to the recommended track placement and adjust track placement accordingly. Ensure the track will be installed into wall studs, wood backing in the wall or a header board that is installed into wall studs.

TRACK INSTALLATION

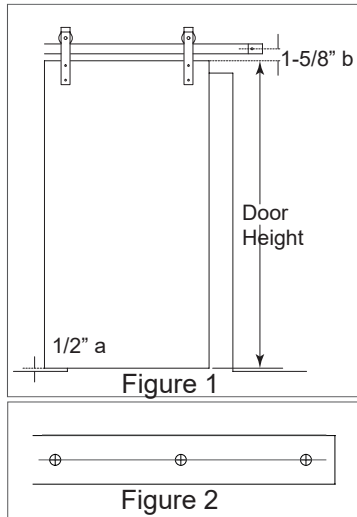

1. To determine where the track should be installed, first measure the height of the door, then add 2-1/8" to the door height. 1/2" (a) will be for the clearance between the bottom edge of the door and the floor. 1-5/8" (b) will be from the top edge of the door to the center of the track. (Figure 1).

2. Using a level and a pencil, make a line on the wall at this height. It will be the centerline of the track.

3. Hold the track up to where the pencil line is visible through the holes in the track. Mark an intersecting line in the center of each hole (Figure 2).

Take the track down, drill out the marked holes using a drill with 1/4" drill bit

4. (Figure 3).

5. Attach one end of the track to the wall with one standard stop, one lag screw, one spacer and one washer, using a socket wrench with 9/16" socket (Figure 4). Do not tighten.

6. Repeat step 5 for the other end of the track.

7. Attach the rubber bumper to the inside of the standard stop. Repeat for the hard stop on the other end of the track (Figure 4a).

8. Install remaining spacers with lag screws and washers using a 9/16" socket wrench (Figure 5). Tighten all lag screws.

9. Hang the doors closest to the wall first by holding the bottom of the door away from the wall (Figure 6).

10. In similar fashion by holding the bottom of the door away from the wall, install the door furthest from the wall on the track

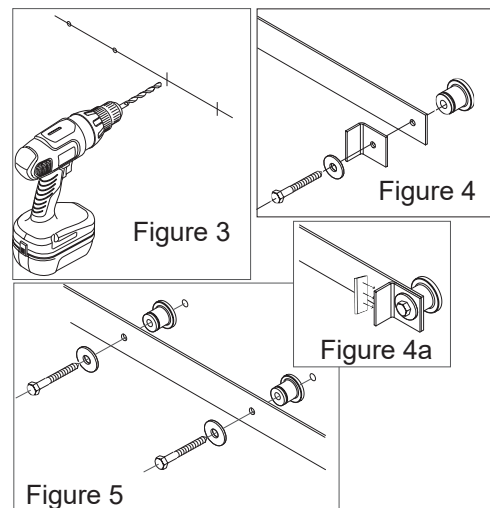

DOOR GUIDE INSTALLATION

1. With the door in the closed position, ensure the door is hanging straight using a bubble level.

2. Position the Door Guide part way into the groove in the bottom of the door (Figure 7).

3. Install the Door Guide using a 1" Phillips screw (provided) and a drill with a Phillips bit.

4. Slide the door toward the open position until the other side of the Door Guide is exposed. Install the second 1" Phillips screw (provided) using a drill with a Phillips bit.

5. Slide the Wall Mount Standard Door Guide 1/2 way under the door furthest from the wall and position on the door closest to the wall.

6. Use the 1/8" drill bit to set a pilot hole use a grabber screw to attach the exposed 1/2 of the guide to door closest to the wall (Figure 8).

7. Then slide the door completely closed and repeat step 4 on the other side.

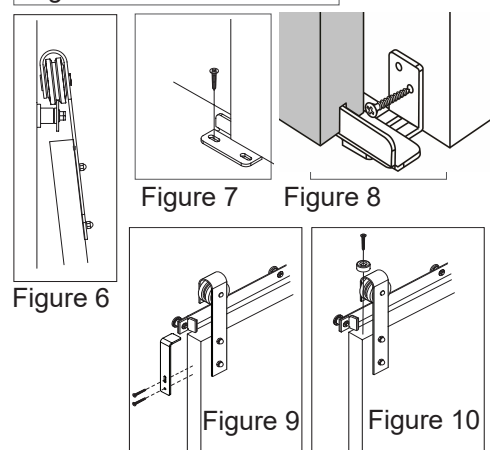

ANTI-JUMP GUIDE INSTALLATION

1. On the doors closest to the wall only, place the Anti-Jump bracket on the door side, moving the bracket up until it is between 1/8" and 1/16" from the bottom edge of the rail. Mark the placement with a pencil. *

2. Install the bracket to the door edge with 2 Phillips screws(provided) using a drill with a Phillips bit (Figure 9).

3. Repeat steps 1 and 2 for the opposite end of the door.

